

4

3

2

1

© - TE Connectivity. All Rights Reserved.

| REVISIONS | | | | | |
|-----------|-----|---------------------------|---------|-----|------|
| P | LTR | DESCRIPTION | DATE | DWN | APVD |
| | A4 | REVISED PER ECR-20-009600 | 06JUL20 | LZ | EW |

⊕ ∅0.30 [.012] Ⓢ AⓈ

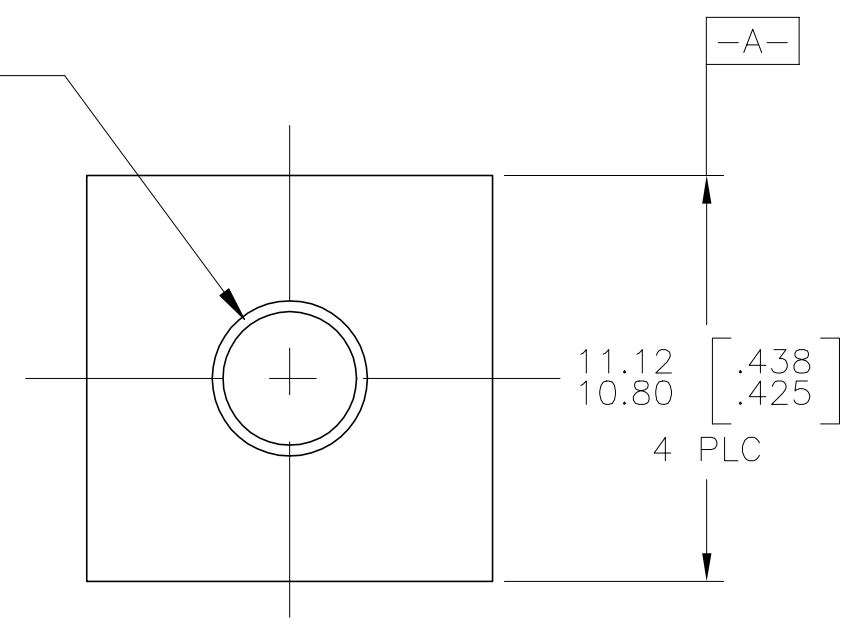

- 1 PLATING: BRIGHT NICKEL 3.8 MICRONS [.000150] MIN.
- 2 THREAD GAGING AFTER PLATING
USE 10-24 UNC 2B FOR "GO"
USE P.D. OF 4.219 [.1661] FOR "NO GO"
HOLE DIA OF 3.962 [.1560] MAX
- 3 NUT MUST WITHSTAND 50 INCH LBS OF
MATING, SCREW TORQUE WITHOUT
DESTRUCTIVE DAMAGE.
- 4 MATERIAL: AISI 4130, 4037, 4135,
C10B21 OR EQUIVALENT.
- 5 RE-PACKAGE NUT #521624-1
1000 PER BOX PER PALI

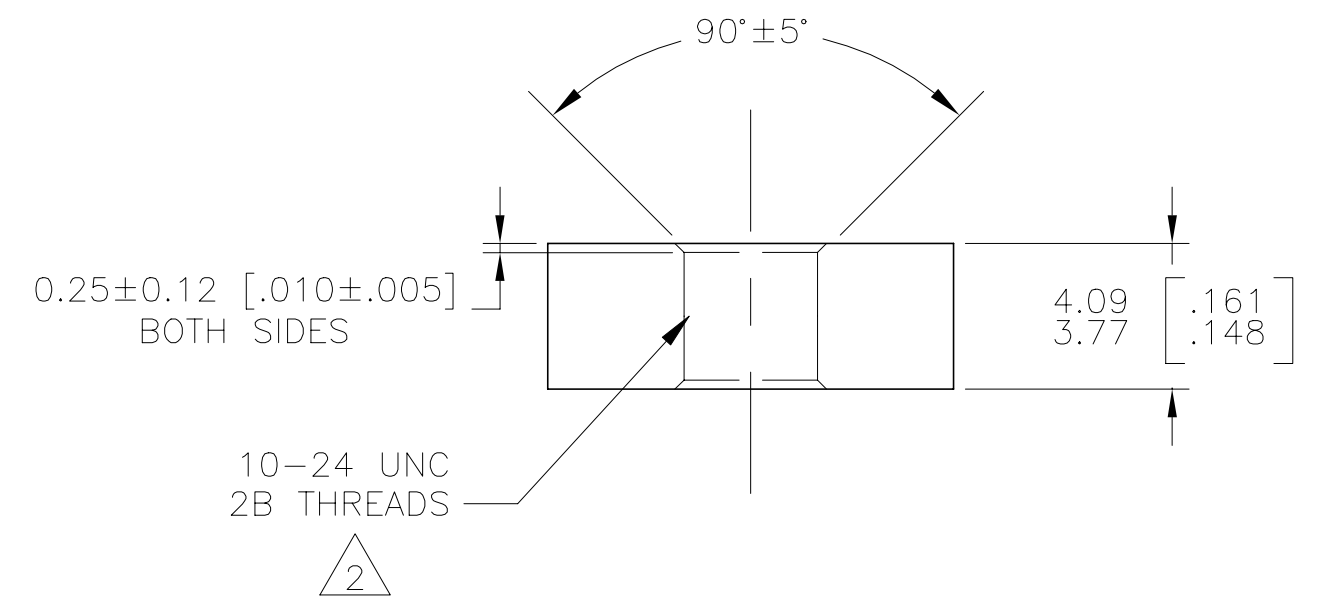

| | |
|----------|------------|
| 1 NICKEL | 5 521624-2 |
| 1 NICKEL | 521624-1 |
| FINISH | PART NO |

| | | | | | | | | | | | | | | | | | |
|---|---------------|------------------|-------------|---------------|----------------------------|-------|---------------|-------|-----|-------|-----|--------|------|------|--|------------------|--|
| THIS DRAWING IS A CONTROLLED DOCUMENT. | | DWN | M.S. FEHER | 19SEP2005 | STE TE Connectivity | | | | | | | | | | | | |
| DIMENSIONS: mm [INCHES] | | CHK | D.F. DECKER | 19SEP2005 | | | | | | | | | | | | | |
| TOLERANCES UNLESS OTHERWISE SPECIFIED: | | APVD | D.F. DECKER | 19SEP2005 | | | | | | | | | | | | | |
| <table border="0"> <tr><td>0 PLC</td><td>± -</td></tr> <tr><td>1 PLC</td><td>± -</td></tr> <tr><td>2 PLC</td><td>± 0.13 [.005]</td></tr> <tr><td>3 PLC</td><td>± -</td></tr> <tr><td>4 PLC</td><td>± -</td></tr> <tr><td>ANGLES</td><td>± 1°</td></tr> </table> | | 0 PLC | ± - | 1 PLC | ± - | 2 PLC | ± 0.13 [.005] | 3 PLC | ± - | 4 PLC | ± - | ANGLES | ± 1° | NAME | | NUT FOR ASSEMBLY | |
| 0 PLC | ± - | | | | | | | | | | | | | | | | |
| 1 PLC | ± - | | | | | | | | | | | | | | | | |
| 2 PLC | ± 0.13 [.005] | | | | | | | | | | | | | | | | |
| 3 PLC | ± - | | | | | | | | | | | | | | | | |
| 4 PLC | ± - | | | | | | | | | | | | | | | | |
| ANGLES | ± 1° | | | | | | | | | | | | | | | | |
| MATERIAL | | PRODUCT SPEC | | SIZE | | | | | | | | | | | | | |
| 4 NICKEL | | FINISH | | CAGE CODE | | | | | | | | | | | | | |
| | | NICKEL | | DRAWING NO | | | | | | | | | | | | | |
| | | WEIGHT | | RESTRICTED TO | | | | | | | | | | | | | |
| | | - | | - | | | | | | | | | | | | | |
| | | CUSTOMER DRAWING | | SCALE | | | | | | | | | | | | | |
| | | | | 5:1 | | | | | | | | | | | | | |
| | | | | SHEET | | | | | | | | | | | | | |
| | | | | 1 OF 1 | | | | | | | | | | | | | |
| | | | | REV | | | | | | | | | | | | | |
| | | | | A4 | | | | | | | | | | | | | |