

DRAWING MADE IN THIRD ANGLE PROJECTION
 THIS DRAWING IS UNPUBLISHED. RELEASED FOR PUBLICATION
 © COPYRIGHT 19 BY AMP INCORPORATED, HARRISBURG, PA. ALL INTERNATIONAL RIGHTS RESERVED. AMP PRODUCTS MAY BE COVERED BY U.S. AND FOREIGN PATENTS AND/OR PATENTS PENDING.

LOC		DIST		P		F		ZONE		LTR		REVISIONS			
BD	77											DESCRIPTION	DATE	APPD	
												A	REV & REDRAWN ECN-1747	-	-
												B	REVISED ECN-BD2289	11-14-88	PAK
												C	REVISED ECN-BD3407	11-13-88	-
												D	SUPSD -2 PER EC 0020-967-93	03/22/94	SB

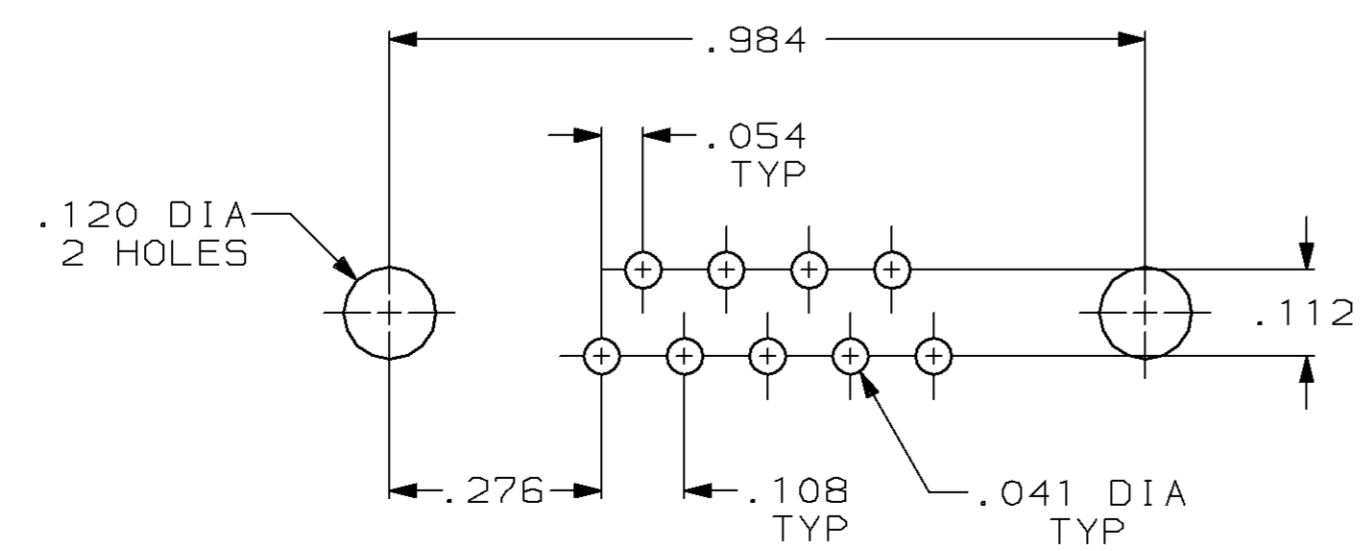
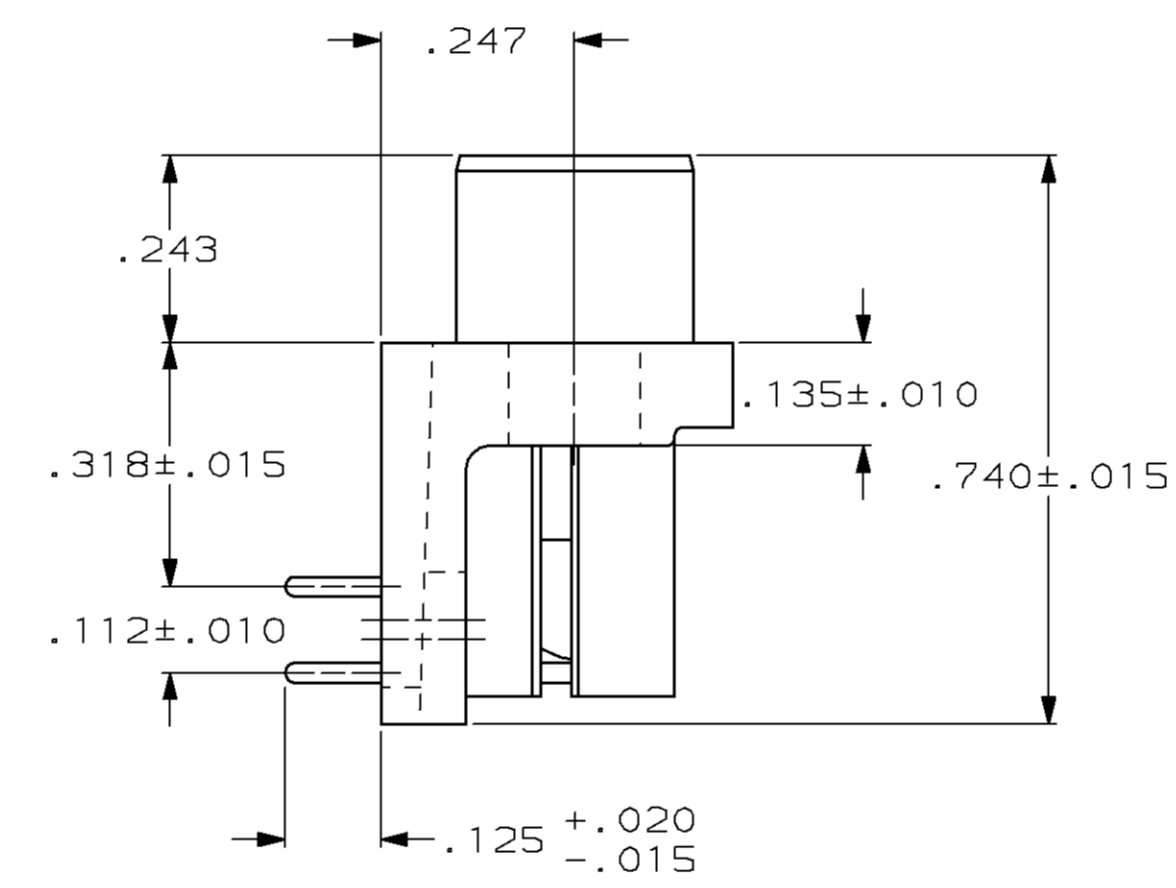
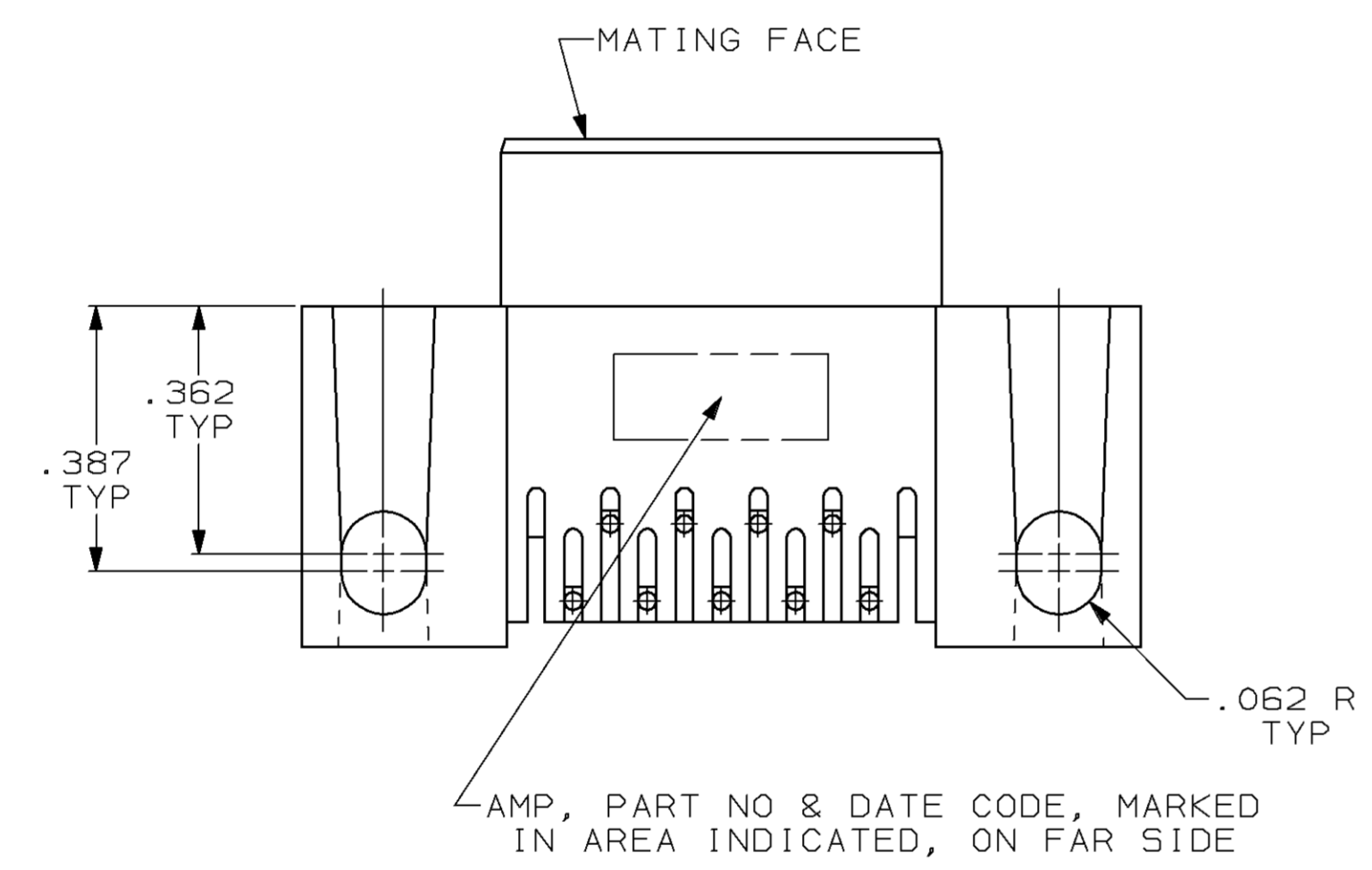
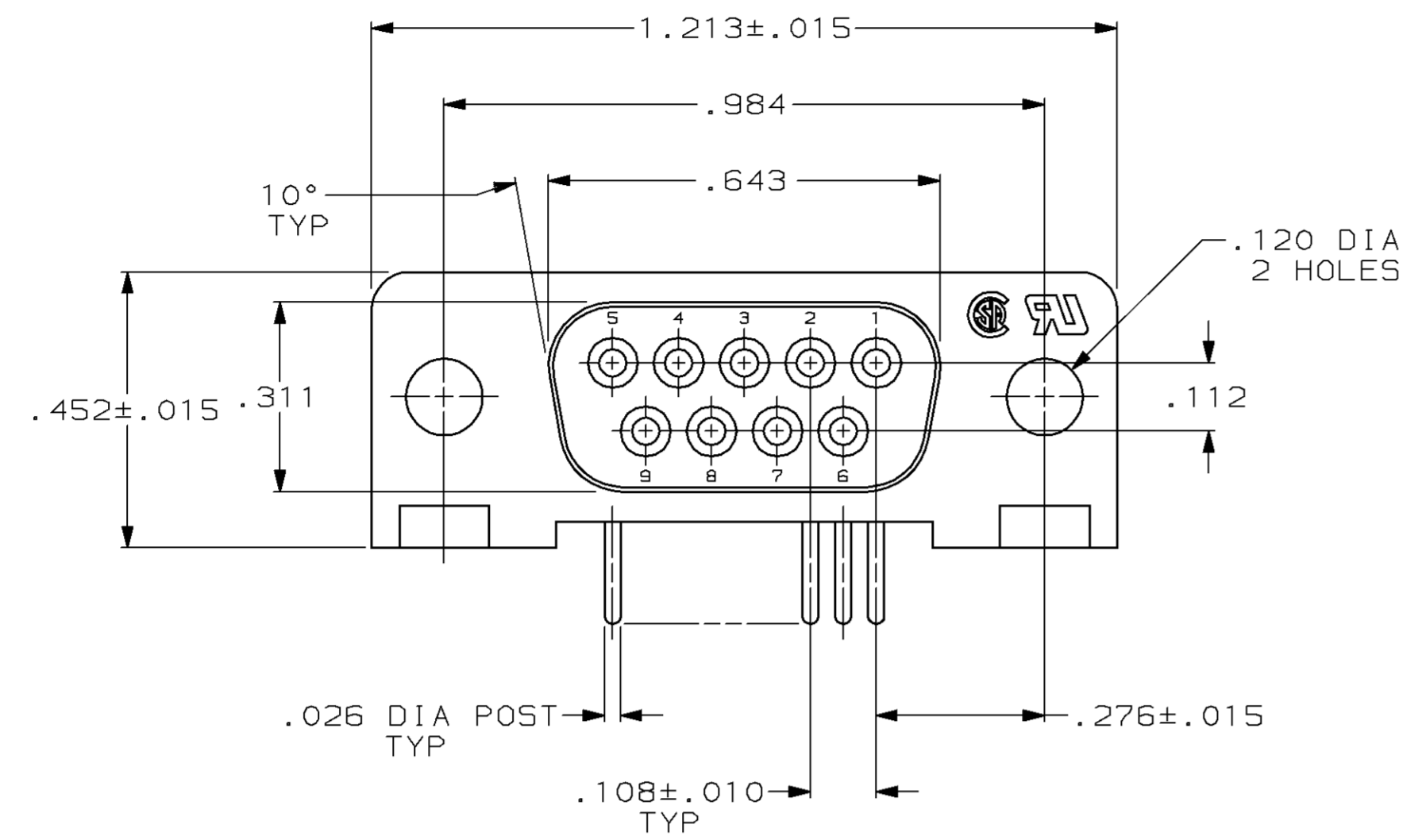

- 1 FLAME RETARDANT, 94V-0 RATED, GLASS FILLED NYLON OR POLYESTER, COLOR: BLACK.
- 2 PHOS. BRONZE PER QQ-B-750.
- 3 REFER TO APPLICATION SPEC FOR RECOMMENDED P.C. BOARD MOUNTING DIMENSIONS FOR AUTOMATIC INSERTION.
- 4 GOLD PLATING PER MIL-G-45204, TIN PLATING PER MIL-T-10727, NICKEL PLATING PER QQ-N-290.
- 5 PLATED WITH GOLD FLASH FOR LENGTH OF .055 MIN FROM MATING END, WITH POINT OF MEASUREMENT .035 FROM MATING END OF CONTACT, .000100-.000200 TIN OR TIN-LEAD ON SOLDER END, ALL OVER .000050 NICKEL ON ENTIRE CONTACT.
- 6 PLATED WITH .000030 GOLD FOR LENGTH OF .055 MIN FROM MATING END, WITH POINT OF MEASUREMENT .035 FROM MATING END OF CONTACT, .000100-.000200 TIN OR TIN-LEAD ON SOLDER END, ALL OVER .000050 NICKEL ON ENTIRE CONTACT.

SUPSD BY 745394-2	745131 -2
	745131 -1
FINISH	PART NUMBER

UNLESS OTHERWISE SPECIFIED DIMENSIONS ARE IN INCHES TOLERANCES ON:		DR 4-7-87 S.WELDON	AMP AMP INCORPORATED Harrisburg, Pa. 17105
2 PL DEC ± .005 3 PL DEC ± .005 ANGLES ± 2°		CHK 4-13-87 C.RICHARD	
MATERIAL	MOLDED PARTS: 1 CONTACTS: 2	APPD 4-27-87 B.TAYLOR	NAME RECEPTACLE ASSY, SIZE 1, 9 POSN, RIGHT ANGLE, .318 SERIES, .026 DIA POSTS, AMPLIMITE® HD-20
FINISH 1 CONTACTS: SEE TABLE		APPD 5-5-87 J.ASSINI	PRODUCT SPEC 108-40005
		APPLICATION SPEC 114-40015	SIZE D 00779
		WEIGHT -	DRAWING NO 745131
		SCALE 4:1	SHEET 1 of 1