

REVISIONS					
REV	ECO	DESCRIPTION	DATE	BY	APPR
A1	-	RELEASED DRAWING	Feb-02-20201	Ronald	Tommy

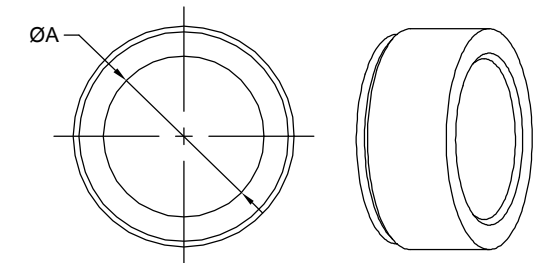
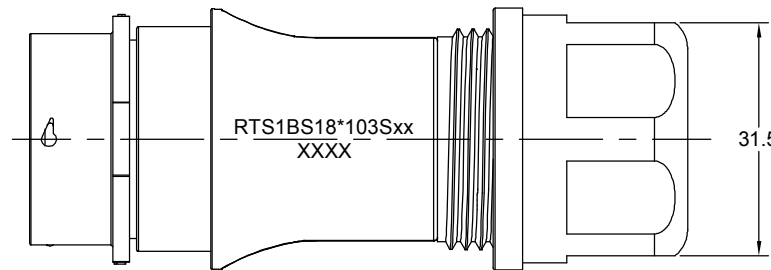
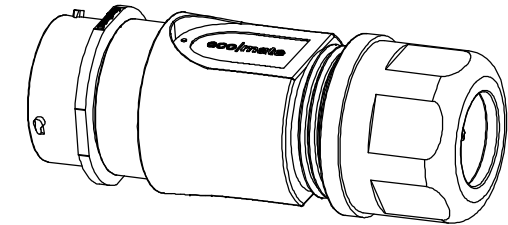
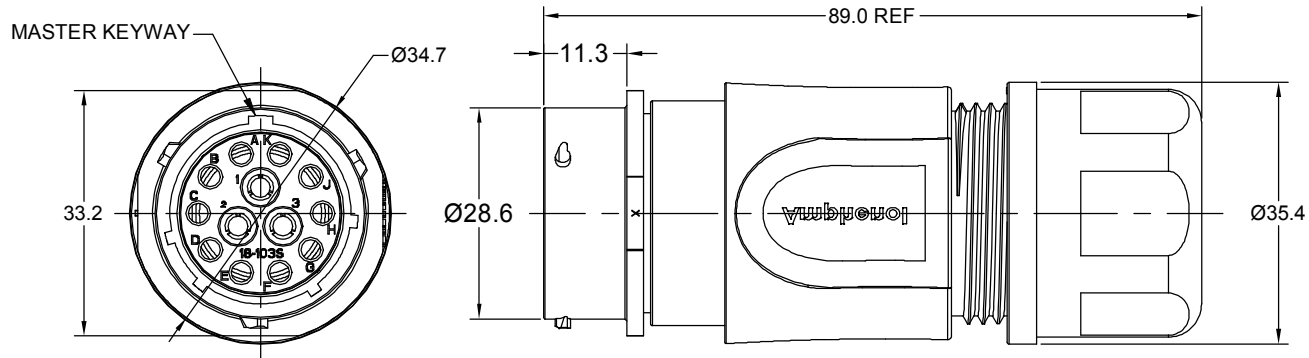

DIMENSION ØA	CABLE OD RANGE
16.5 mm	10.0-16.0 mm
18.5 mm	12.0-18.0 mm

NOTES : (UNLESS OTHERWISE SPECIFIED)

1. MATERIAL :

- SHELL : THERMOPLASTIC , UL94 V-0.
- INSERT : THERMOPLASTIC , UL94 V-0.
- O-RING : NBR/SILICONE RUBBER.
- BACK SHELL : THERMOPLASTIC , UL94 V-0.
- CLAMP NUT : THERMOPLASTIC , UL94 V-0.
- CLAMP RING : THERMOPLASTIC , UL94 V-0.
- CABLE SEAL : EPDM.

2. SPECIFICATIONS :

2.1 RATED CURRENT :

- 2.1.1 16# CONTACT 13A (MAX).
- 2.1.2 RF CONTACT 1A (MAX) .

2.2 RATED VOLTAGE : 500V(AC/DC).

2.3 OPERATING TEMPERATURE : SEE TABLE .

2.4 DIELECTRIC WITHSTANDING VOLTAGE : LESS THAN 2 MILLIAMPS CURRENT LEAKAGE@2000 VOLTS AC.

2.5 INSULATION RESISTANCE : 5000 MEGOHMS MIN.

2.6 IP--CLASS : IP67 AND IP69K IN THE MATED CONDITION.

2.7 MATING CYCLES DURABILITY : 500 CYCLES MIN.

2.8 RoHS COMPLIANT.

3. SUITABLE CONTACTS : 16# & RF CONTACTS.

4. ALL DIMENSIONS ARE FOR REFERENCE USE ONLY.

KEY	PART NUMBER	
	-40°C ~ +105°C	-40°C ~ +125°C
N	RTS1BS18N103S	RTS1BS18N103S03

QUANTITY	PART NUMBER	DESCRIPTION	ITEM														
MATERIALS LIST																	
UNLESS OTHERWISE SPECIFIED		SIGNATURES	DATE														
1) All dimensions are in metric(mm).		DRAWN: Ronald	Feb-02-21														
2) Tolerances are as follows:		CHECKED: Flan	Feb-03-21														
1 PL DEC ±0.30		ENGINEER:															
2 PL DEC ±0.15		APPROVAL: Tommy	Feb-04-21														
3 PL DEC ±0.08		CUSTOMER:															
3) Note reference =		THIS DRAWING IS SUPPLIED FOR INFORMATION ONLY. DESIGN FEATURES, SPECIFICATIONS AND PERFORMANCE DATA SHOWN HEREON ARE THE PROPERTY OF THE AMPHENOL CORPORATION. NO RIGHTS OF REPRODUCTION ARE IMPLIED. ALL DIMENSIONS ARE SUBJECT TO NORMAL MANUFACTURING VARIATIONS.															
MATERIAL SPECIFICATIONS:		<p style="text-align: center;">Amphenol</p> <p>Sine Systems - www.amphenol-sine.com 44724 Morley Drive Clinton Township, MI 48036</p>															
PROCESS SPECIFICATIONS:		<p style="text-align: center;">ECOMATE AQUARIUS, RECPTACLE, BACK SHELL, SIZE 18,10+3 POS, SOCKET</p>															
NEXT ASSY:		<table border="1"> <thead> <tr> <th>SIZE</th> <th>TYPE</th> <th>DWG NO.</th> <th>REVISION</th> </tr> </thead> <tbody> <tr> <td>B</td> <td>C-</td> <td>RTS1BS18*103Sxx</td> <td>A1</td> </tr> </tbody> </table>	SIZE	TYPE	DWG NO.	REVISION	B	C-	RTS1BS18*103Sxx	A1	<table border="1"> <thead> <tr> <th>SCALE</th> <th>SHEET</th> <th>OF</th> </tr> </thead> <tbody> <tr> <td>NONE</td> <td>1</td> <td>1</td> </tr> </tbody> </table>	SCALE	SHEET	OF	NONE	1	1
SIZE	TYPE	DWG NO.	REVISION														
B	C-	RTS1BS18*103Sxx	A1														
SCALE	SHEET	OF															
NONE	1	1															

TITLE: ECOMATE AQUARIUS, RECPTACLE, BACK SHELL, SIZE 18,10+3 POS, SOCKET
DWG NO.: RTS1BS18*103Sxx
REV: A1
SH: 1
OF: 1

ecomate® RM/RSSM/Aquarius™ - Contact Size 16 Options

Crimp Contacts, Machined				
Part Number		AWG	Wire Range (mm ²)	Plating
Male	Female			
MP14M23F	MS14M23F	14	2.0-2.5	Gold Flash
MP14M23G5	MS14M23G5	14	2.0-2.5	Gold 5μ"
MP14M23G10	MS14M23G10	14	2.0-2.5	Gold 10μ"
MP14M23G15	MS14M23G15	14	2.0-2.5	Gold 15μ"
MP14M23G30	MS14M23G30	14	2.0-2.5	Gold 30μ"
MP16M23F	MS16M23F	18-16	0.75-1.5	Gold Flash
MP16M23G5	MS16M23G5	18-16	0.75-1.5	Gold 5μ"
MP16M23G10	MS16M23G10	18-16	0.75-1.5	Gold 10μ"
MP16M23G15	MS16M23G15	18-16	0.75-1.5	Gold 15μ"
MP16M23G30	MS16M23G30	18-16	0.75-1.5	Gold 30μ"
MP20M23F	MS20M23F	22-20	0.34-0.50	Gold Flash
MP20M23G5	MS20M23G5	22-20	0.34-0.50	Gold 5μ"
MP20M23G10	MS20M23G10	22-20	0.34-0.50	Gold 10μ"
MP20M23G15	MS20M23G15	22-20	0.34-0.50	Gold 15μ"
MP20M23G30	MS20M23G30	22-20	0.34-0.50	Gold 30μ"
MP24M23F	MS24M23F	26-24	0.14-0.25	Gold Flash
MP24M23G5	MS24M23G5	26-24	0.14-0.25	Gold 5μ"
MP24M23G10	MS24M23G10	26-24	0.14-0.25	Gold 10μ"
MP24M23G15	MS24M23G15	26-24	0.14-0.25	Gold 15μ"
MP24M23G30	MS24M23G30	26-24	0.14-.025	Gold 30μ"

Tooling, Machined	
Part Number	Description
QXRT16	Contact Extraction Tool, #16 (Ø 1.6) Contact
MFX-3959	Hand Crimp Tool for Machined Contacts
MFX-3960	Pneumatic Crimp Tool for Machined Contact

Plating Options, All	
Symbol	Plating
T	Tin Plated (for Stamped & Formed Contacts)
S	Silver Plated 5Um (for Machined Contacts)
F	Gold Plated
G5	Gold Plated (Thickness 5μ")
G10	Gold Plated (Thickness 10μ")
G15	Gold Plated (Thickness 15μ")
G30	Gold Plated (Thickness 30μ")

Crimp Contacts, Stamped & Formed				
Part Number		AWG	Wire Range (mm ²)	Plating
Male	Female			
SP14M2F	SS14M2F	14	2.0-2.5	Gold Flash
SP14M2G5	SS14M2G5	14	2.0-2.5	Gold 5μ"
SP14M2G10	SS14M2G10	14	2.0-2.5	Gold 10μ"
SP14M2G15	SS14M2G15	14	2.0-2.5	Gold 15μ"
SP14M2G30	SS14M2G30	14	2.0-2.5	Gold 30μ"
SP16M2F	SS16M2F	18-16	0.75-1.5	Gold Flash
SP16M2G5	SS16M2G5	18-16	0.75-1.5	Gold 5μ"
SP16M2G10	SS16M2G10	18-16	0.75-1.5	Gold 10μ"
SP16M2G15	SS16M2G15	18-16	0.75-1.5	Gold 15μ"
SP16M2G30	SS16M2G30	18-16	0.75-1.5	Gold 30μ"
SP20M2F	SS20M2F	22-20	0.34-0.50	Gold Flash
SP20M2G5	SS20M2G5	22-20	0.34-0.50	Gold 5μ"
SP20M2G10	SS20M2G10	22-20	0.34-0.50	Gold 10μ"
SP20M2G15	SS20M2G15	22-20	0.34-0.50	Gold 15μ"
SP20M2G30	SS20M2G30	22-20	0.34-0.50	Gold 30μ"
SP24M2F	SS24M2F	26-24	0.14-0.25	Gold Flash
SP24M2G5	SS24M2G5	26-24	0.14-0.25	Gold 5μ"
SP24M2G10	SS24M2G10	26-24	0.14-0.25	Gold 10μ"
SP24M2G15	SS24M2G15	26-24	0.14-0.25	Gold 15μ"
SP24M2G30	SS24M2G30	26-24	0.14-0.25	Gold 30μ"

Tooling, Stamped & Formed	
Part Number	Description
QXRT16	Contact Extraction Tool, #16 (Ø 1.6) Contact
MFX-3954	Hand Tool, Stamped & Formed Contact, Size 16, 20-14AWG
MFX-3957	Crimp Die, Stamped & Formed Contact

Misc Tooling, All	
Part Number	Description
CA-4020-59	Sealing Plug, Size 16 & 20

Standard Quantity Order Options	
Machined	Stamped & Formed
Bulk Package, 500 Pieces	Reel, 3000 Pieces

1 | 2 | 3 | 4

A

B

C

D

E

F

A

B

C

D

E

F

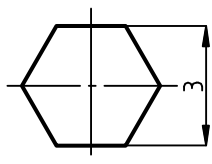
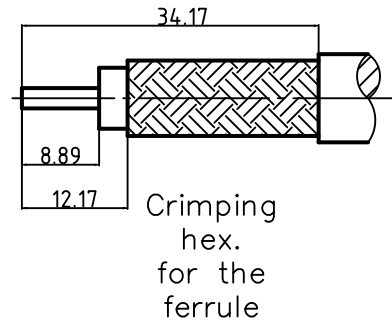
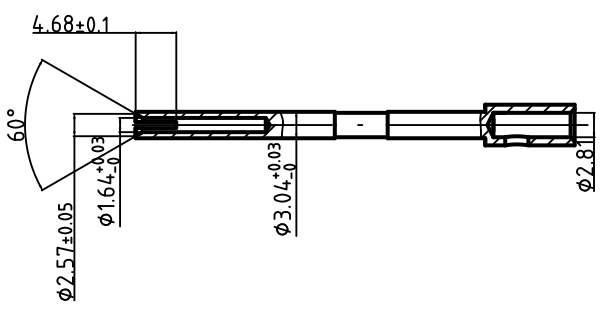
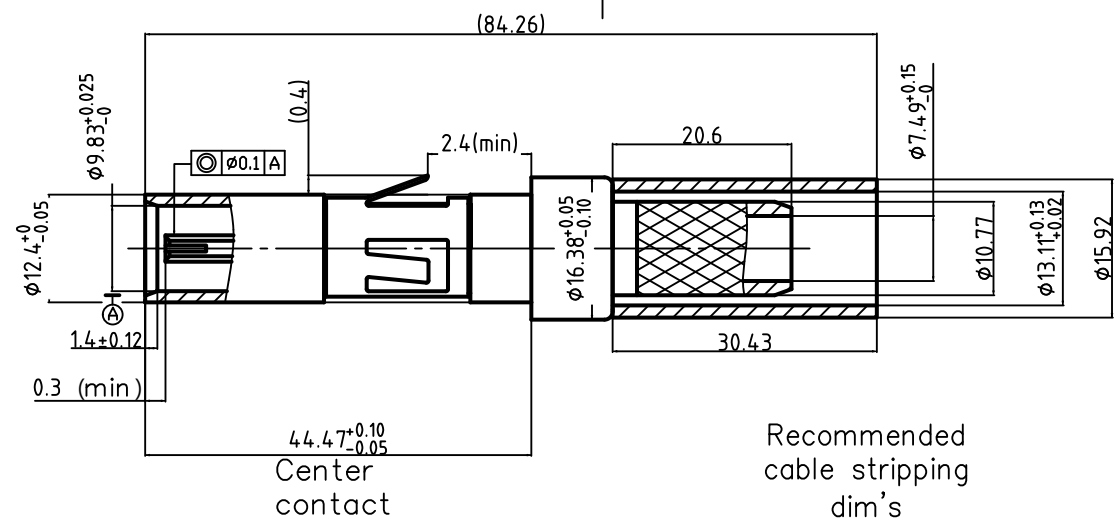

Recommended cable stripping dim's

Crimping hex. for the ferrule

BUILD INSTRUCTIONS:
SLIDE AMPHENOL SINE SYSTEMS ALIGNMENT COLLAR 20-80646 ON COAX CABLE (PURCHASED SEPARATELY).

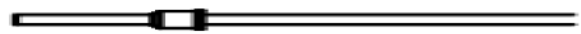

PREP CABLE AS SHOWN ABOVE. SOLDER CENTER CONTACT ONTO THE CENTER CONDUCTOR.



SLIDE THE CRIMP FERRULE OVER THE COAX CABLE AND PUSH THE CENTER PIN INTO COAX CONTACT.



CRIMP FERRULE USING DANIELS CRIMPER HX4 AND DIE SET Y193.



Electrical Characteristics:

- Characteristic impedance: 50Ω
- Working voltage: 500V(rms)
- Frequency range: 0-10GHz
- Dielectric withstanding voltage: 750V(volts RMS)
- Contact resistance: Center contact: ≤10mΩ, Outer contact: ≤3mΩ
- Insulation resistance: ≥1000MΩ
- VSWR: <1.30(0-3GHz)

Note:

- 1.Match cable: RG-316/U
- 2.Center contact :Solder
- 3.Outer contact: Crimp

4	Ferrule	Copper alloy	Nickel	1	
3	Body	Brass	Gold	1	
2	Insulator	PTFE	---	1	
1	Center contact	Beryllium copper	Gold	1	
NO.	Title/Name	Material	Finish	QTY	Remark

Customer Code. AFN	Customer part NO.	Designed Date J-0030 2011.01.28	
Unless otherwise specified tolerance X.XX±0.1	X±0.3	Checked Date J-0006 2011.01.28	
X.X±0.2	Ang.±1°		
Notice: This document is the property of Amphenol ,reproduction or disclosure is forbidden unless authorized by Amphenol.			

AMPHENOL	
Part No	MIM-K2.5Y
Drawing No	MIM.1212006/R/1
Scale 5:1	Sheet 1/1
Rev.	V6.0

1 | 4

REV	ZONE	ECO	DESCRIPTION	DATE	BY	APPR
01	--	--	RELEASE NUMBER	Jul-16-20	Ronald	Tommy
02	--	--	CHANGE ϕ 4.5 to ϕ 4.55	Sep-14-20	Ronald	Tommy

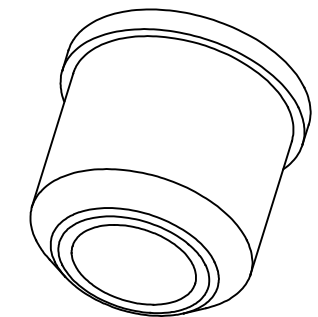
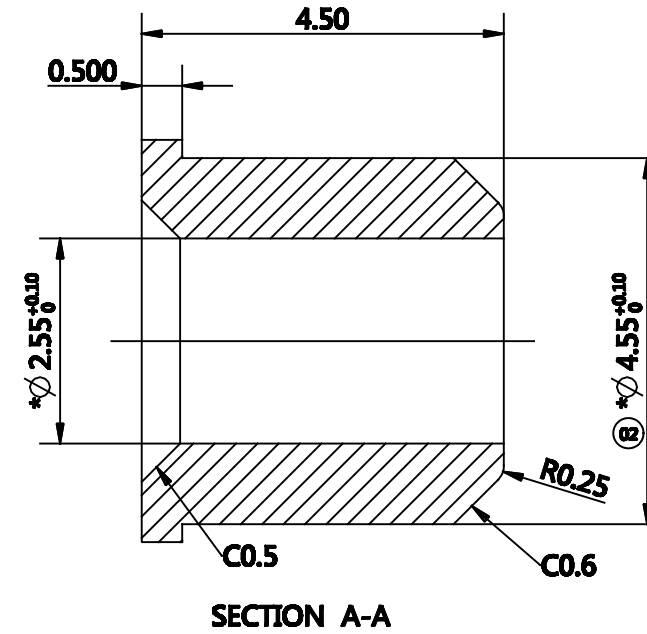
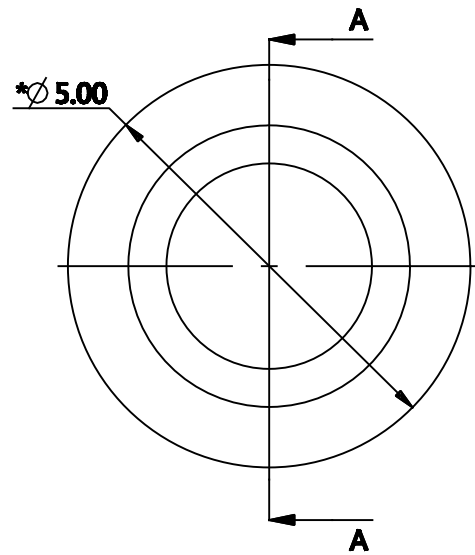

NOTES:

- PARTS TO BE FREE OF NICKS, BURRS, FLASH, TOOL MARKS, OR OTHER DEFECTS THAT MAY AFFECT PART FUNCTION.
- ALL UNSPECIFIED RADIUS TO BE R0.2.
- ALL DIMENSIONS ARE AFTER SHRINKAGE.
- "*" DENOTES KPC (KEY PRODUCT CHARACTERISTIC).
- ALL DIMENSIONS NOT SHOWN TO BE MEASURED FROM CAD MODEL.
- ROHS COMPLIANT.

MATERIALS LIST												
UNLESS OTHERWISE SPECIFIED 1) All dimensions are in metric(mm). 2) Tolerances are as follows: 1 PL DEC ± 0.20 2 PL DEC ± 0.10 Fractions $\pm 1/64$ 3 PL DEC ± 0.05 Angles $\pm 1^\circ$			MATERIAL SPECIFICATIONS:			SINE Systems Corporation A Subsidiary of Amphenol Corporation COLLAR						
			PP							PROCESS SPECIFICATIONS:		
SIGNATURE		DATE		THIS DRAWING IS SUPPLIED FOR INFORMATION ONLY. DESIGN FEATURES, SPECIFICATIONS AND PERFORMANCE DATA SHOWN HEREON ARE THE PROPERTY OF THE AMPHENOL CORPORATION. NO RIGHTS OF REPRODUCTION ARE IMPLIED. ALL DIMENSIONS ARE SUBJECT TO NORMAL MANUFACTURING VARIATIONS.			DWG NO.		20-80646			
DRAWN		Ronald Jul-16-20					THIRD ANGLE PROJECTION		FSCM NO.		SIZE MASS REV SCALE	
CHECKED							⊕		A4		02 & 1	
ENGINEER							SHEET 1 OF 1		NEXT ASS'Y:			
APPROVAL												
CUSTOMER												