

# KMZ41

## Magnetic field sensor

Rev. 6 — 18 November 2010

Product data sheet

## 1. Product profile

### 1.1 General description

The KMZ41 is a sensitive magnetic field sensor, employing the magneto-resistive effect of thin film permalloy. The sensor contains two galvanically separated Wheatstone bridges, which enclose an angle of 45 degrees.

A rotating magnetic field strength  $> 40$  kA/m (recommended field strength  $> 100$  kA/m) in the surface parallel to the chip (x-y plane) will deliver two independent sinusoidal output signals, one following a  $\cos(2\alpha)$  and the second following a  $\sin(2\alpha)$  function.

The sensor can be operated at any frequency between DC and 1 MHz.

### 1.2 Features and benefits

- Accurate and reliable angle measurement
- Mechanical robustness, contactless principle
- Wear-free operation
- Accuracy independent of mechanical tolerances
- Extended temperature range

### 1.3 Quick reference data

**Table 1. Quick reference data**

$T_{amb} = 25$  °C and  $H_{ext} = 100$  kA/m,  $V_{CC} = 5$  V unless otherwise specified.

Symbol	Parameter	Conditions	Min	Typ	Max	Unit
$V_{CC}$	supply voltage		[1] -	5	9	V
$V_{peak}$	peak voltage	see <a href="#">Figure 2</a>	[1] 73	81	89	mV
$V_{offset}$	offset voltage	per supply voltage; see <a href="#">Figure 2</a>	[1] -2	-	+2	mV/V
$R_{bridge}$	bridge resistance		[1][2] 2.0	2.5	3.0	k $\Omega$

[1] Applicable for bridge 1 and bridge 2.

[2] Bridge resistance between pin 4 and pin 8, pin 3 and pin 7, pin 5 and pin 1, pin 6 and pin 2.



## 2. Pinning information

Table 2. Pinning

Pin	Symbol	Description	Simplified outline
1	ON1	output voltage bridge 1	
2	ON2	output voltage bridge 2	
3	V <sub>CC2</sub>	supply voltage bridge 2	
4	V <sub>CC1</sub>	supply voltage bridge 1	
5	OP1	output voltage bridge 1	
6	OP2	output voltage bridge 2	
7	GND2	supply voltage bridge 2	
8	GND1	supply voltage bridge 1	

## 3. Ordering information

Table 3. Ordering information

Type number	Package		Version
	Name	Description	
KMZ41	SO8	plastic small outline package; 8 leads; body width 3.9 mm	SOT96-1

## 4. Circuit diagram

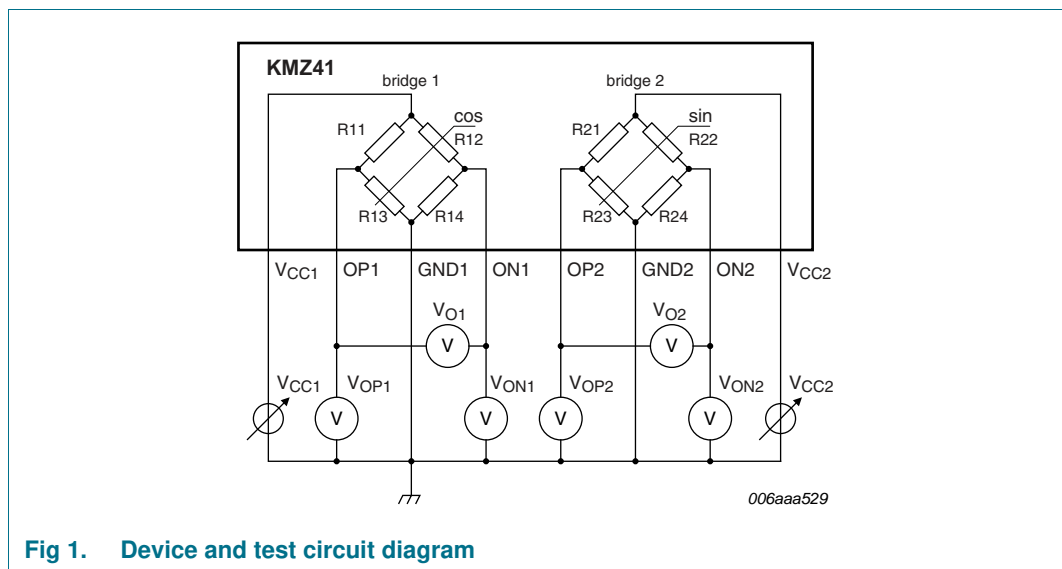

Fig 1. Device and test circuit diagram

## 5. Limiting values

**Table 4. Limiting values**

*In accordance with the Absolute Maximum Rating System (IEC 60134).*

Symbol	Parameter	Conditions	Min	Max	Unit
V <sub>CC</sub>	supply voltage	[1]	-	9	V
H <sub>ext</sub>	external magnetic field strength		40	-	kA/m
T <sub>amb</sub>	ambient temperature		-40	+150	°C
T <sub>stg</sub>	storage temperature		-65	+150	°C

[1] Applicable for bridge 1 and bridge 2.

## 6. Thermal characteristics

**Table 5. Thermal characteristics**

Symbol	Parameter	Conditions	Typ	Unit
R <sub>th(j-a)</sub>	thermal resistance from junction to ambient		155	K/W

## 7. Characteristics

**Table 6. Characteristics**

$T_{amb} = 25\text{ °C}$  and  $H_{ext} = 100\text{ kA/m}$ ,  $V_{CC} = 5\text{ V}$  unless otherwise specified.

Symbol	Parameter	Conditions	Min	Typ	Max	Unit
$V_{CC}$	supply voltage		[1] -	5	9	V
$V_{peak}$	peak voltage	see <a href="#">Figure 2</a>	[1] 73	81	89	mV
$TCV_{peak}$	temperature coefficient of peak voltage	$T_{amb} = -40\text{ °C}$ to $+150\text{ °C}$	[1][2] -0.38	-0.41	-0.44	%/K
$R_{bridge}$	bridge resistance		[1][3] 2.0	2.5	3.0	k $\Omega$
$TCR_{bridge}$	temperature coefficient of bridge resistance	$T_{amb} = -40\text{ °C}$ to $+150\text{ °C}$	[1][4] 0.31	0.33	0.35	%/K
$V_{offset}$	offset voltage	per supply voltage; see <a href="#">Figure 2</a>	[1] -2	-	+2	mV/V
$TCV_{offset}$	temperature coefficient of offset voltage	per supply voltage; $T_{amb} = -40\text{ °C}$ to $+150\text{ °C}$ ; see <a href="#">Figure 2</a>	[1][5] -2	-	+2	( $\mu$ V/V)/K
FH	hysteresis of output voltage	see <a href="#">Figure 3</a>	[1][6] 0	0.01	0.04	%FS
k	amplitude synchronism		[7] 99	100	101	%
Tck	temperature coefficient of amplitude synchronism	$T_{amb} = -40\text{ °C}$ to $+150\text{ °C}$	[8] -0.005	0	+0.005	%/K
$\Delta\alpha$	angular inaccuracy		[9] 0	0.1	0.25	deg

[1] Applicable for bridge 1 and bridge 2.

$$[2] \quad TCV_{peak} = 100 \times \frac{V_{peak}(at\ 150\text{ °C}) - V_{peak}(at\ -40\text{ °C})}{V_{peak}(at\ 25\text{ °C}) \times (150\text{ °C} - (-40\text{ °C}))}$$

[3] Bridge resistance between pin 4 and pin 8, pin 3 and pin 7, pin 5 and pin 1, pin 6 and pin 2.

$$[4] \quad TCR_{bridge} = 100 \times \frac{R_{bridge}(at\ 150\text{ °C}) - R_{bridge}(at\ -40\text{ °C})}{R_{bridge}(at\ 25\text{ °C}) \times (150\text{ °C} - (-40\text{ °C}))}$$

$$[5] \quad TCV_{offset} = \frac{V_{offset}(at\ 150\text{ °C}) - V_{offset}(at\ -40\text{ °C})}{150\text{ °C} - (-40\text{ °C})}$$

$$[6] \quad FH_1 = 100 \times \left| \frac{V_{O1}(67.5^\circ)135^\circ \rightarrow 45^\circ - V_{O1}(67.5^\circ)45^\circ \rightarrow 135^\circ}{2 \times V_{peak1}} \right|$$

$$FH_2 = 100 \times \left| \frac{V_{O2}(22.5^\circ)90^\circ \rightarrow 0^\circ - V_{O2}(22.5^\circ)0^\circ \rightarrow 90^\circ}{2 \times V_{peak2}} \right|$$

$$[7] \quad k = 100 \times \frac{V_{peak1}}{V_{peak2}}$$

$$[8] \quad Tck = 100 \times \frac{k(at\ 150\text{ °C}) - k(at\ -40\text{ °C})}{k(at\ 25\text{ °C}) \times (150\text{ °C} - (-40\text{ °C}))}$$

[9]  $\Delta\alpha = |\alpha_{real} - \alpha_{meas}|$ ;  $V_{offset} = 0\text{ V}$ ; inaccuracy of angular measurement due to deviation from ideal sinusoidal characteristics, calculated from the third and fifth harmonics of the spectrum of  $V_O$ .

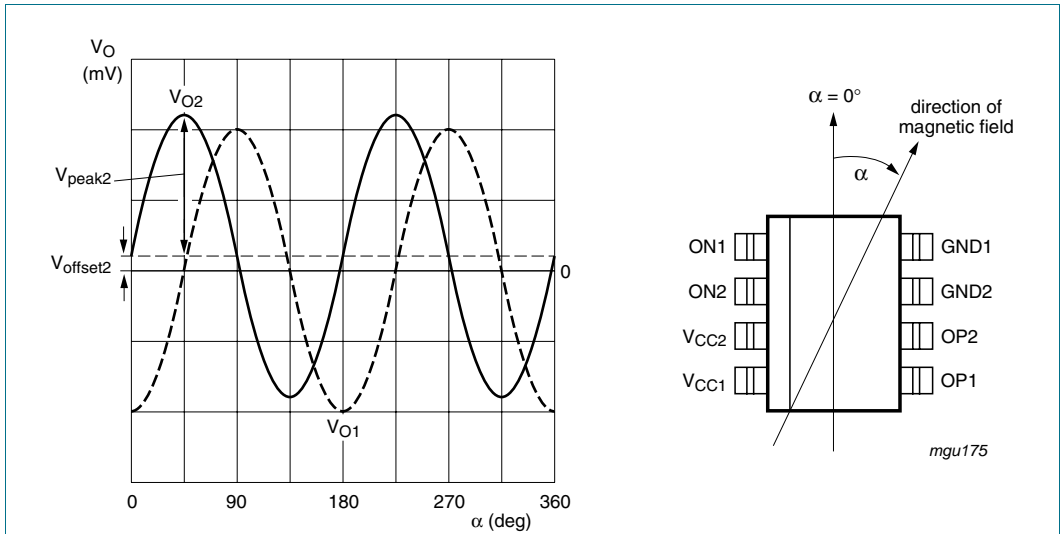

Fig 2. Output signals related to the direction of the magnetic field

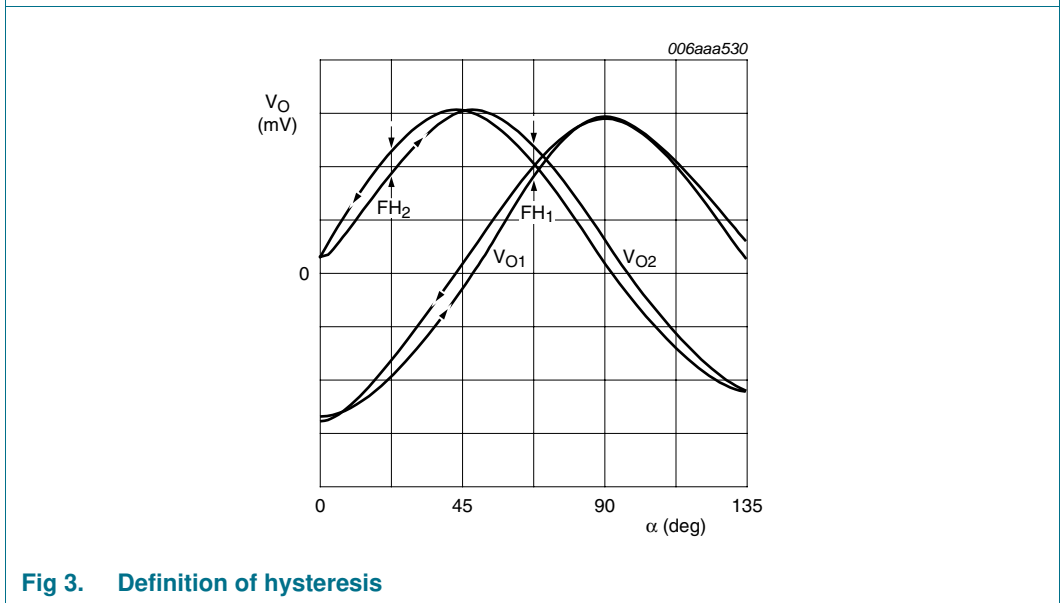

Fig 3. Definition of hysteresis

8. Package outline

SO8: plastic small outline package; 8 leads; body width 3.9 mm

SOT96-1

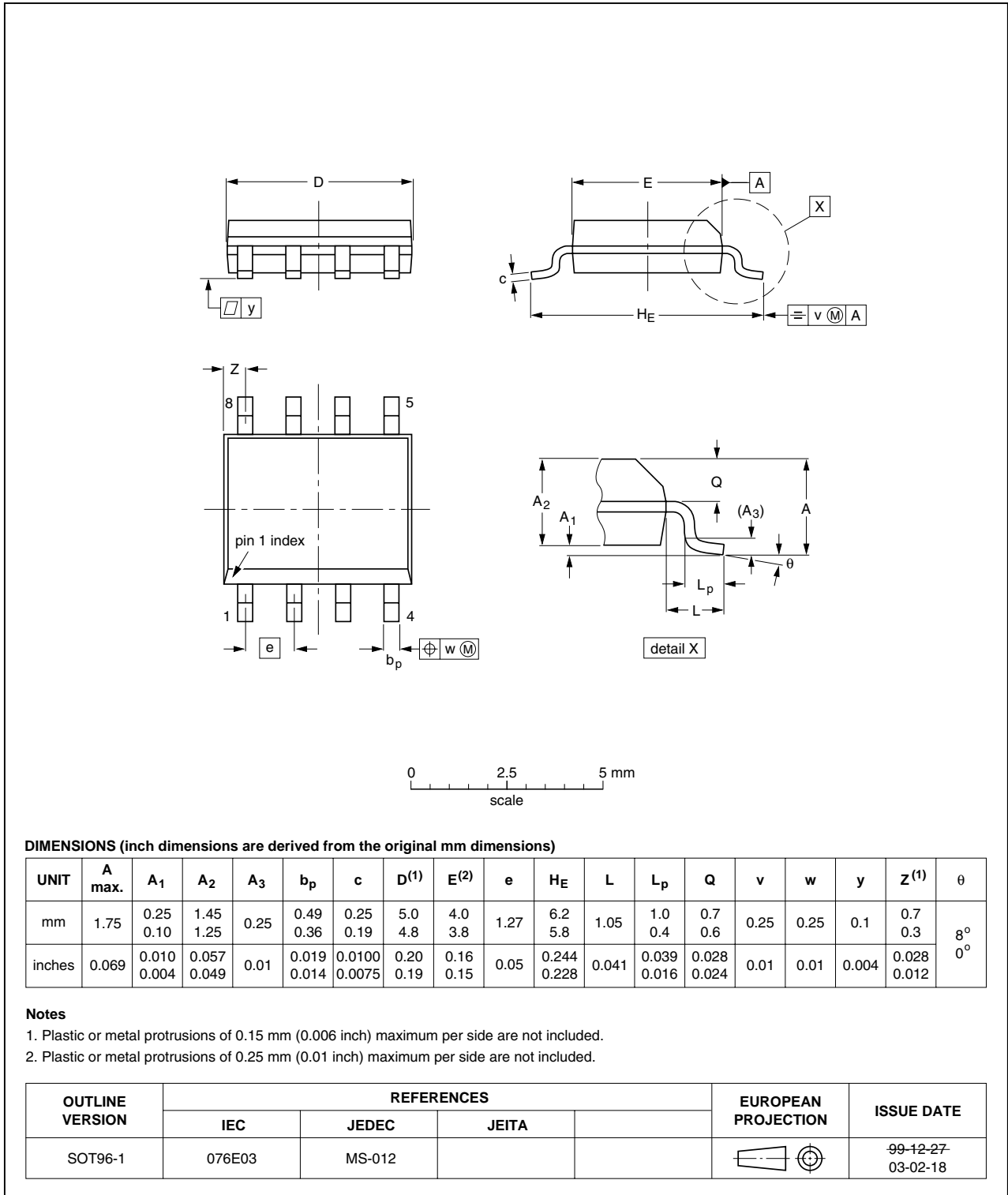

Fig 4. Package outline SOT96-1 (SO8/MS-012)

## 9. Packing information

**Table 7. Packing methods**

The indicated -xxx are the last three digits of the 12NC ordering code.<sup>[1]</sup>

Type number	Package	Description	Packing quantity
			2500
KMZ41	SOT96-1	8 mm pitch, 12 mm tape and reel	-118

[1] 12NC ordering code: 9340 372 10118. For further information and the availability of packing methods, see [Section 12](#).

## 10. Revision history

**Table 8. Revision history**

Document ID	Release date	Data sheet status	Change notice	Supersedes
KMZ41 v.6	20101118	Product data sheet	CPCN201007013F	KMZ41_5
KMZ41_5	20061127	Product data sheet	-	KMZ41_4

## 11. Legal information

### 11.1 Data sheet status

Document status <sup>[1][2]</sup>	Product status <sup>[3]</sup>	Definition
Objective [short] data sheet	Development	This document contains data from the objective specification for product development.
Preliminary [short] data sheet	Qualification	This document contains data from the preliminary specification.
Product [short] data sheet	Production	This document contains the product specification.

[1] Please consult the most recently issued document before initiating or completing a design.

[2] The term 'short data sheet' is explained in section "Definitions".

[3] The product status of device(s) described in this document may have changed since this document was published and may differ in case of multiple devices. The latest product status information is available on the Internet at URL <http://www.nxp.com>.

### 11.2 Definitions

**Draft** — The document is a draft version only. The content is still under internal review and subject to formal approval, which may result in modifications or additions. NXP Semiconductors does not give any representations or warranties as to the accuracy or completeness of information included herein and shall have no liability for the consequences of use of such information.

**Short data sheet** — A short data sheet is an extract from a full data sheet with the same product type number(s) and title. A short data sheet is intended for quick reference only and should not be relied upon to contain detailed and full information. For detailed and full information see the relevant full data sheet, which is available on request via the local NXP Semiconductors sales office. In case of any inconsistency or conflict with the short data sheet, the full data sheet shall prevail.

**Product specification** — The information and data provided in a Product data sheet shall define the specification of the product as agreed between NXP Semiconductors and its customer, unless NXP Semiconductors and customer have explicitly agreed otherwise in writing. In no event however, shall an agreement be valid in which the NXP Semiconductors product is deemed to offer functions and qualities beyond those described in the Product data sheet.

### 11.3 Disclaimers

**Limited warranty and liability** — Information in this document is believed to be accurate and reliable. However, NXP Semiconductors does not give any representations or warranties, expressed or implied, as to the accuracy or completeness of such information and shall have no liability for the consequences of use of such information.

In no event shall NXP Semiconductors be liable for any indirect, incidental, punitive, special or consequential damages (including - without limitation - lost profits, lost savings, business interruption, costs related to the removal or replacement of any products or rework charges) whether or not such damages are based on tort (including negligence), warranty, breach of contract or any other legal theory.

Notwithstanding any damages that customer might incur for any reason whatsoever, NXP Semiconductors' aggregate and cumulative liability towards customer for the products described herein shall be limited in accordance with the *Terms and conditions of commercial sale* of NXP Semiconductors.

**Right to make changes** — NXP Semiconductors reserves the right to make changes to information published in this document, including without limitation specifications and product descriptions, at any time and without notice. This document supersedes and replaces all information supplied prior to the publication hereof.

**Suitability for use in automotive applications** — This NXP Semiconductors product has been qualified for use in automotive applications. The product is not designed, authorized or warranted to be

suitable for use in medical, military, aircraft, space or life support equipment, nor in applications where failure or malfunction of an NXP Semiconductors product can reasonably be expected to result in personal injury, death or severe property or environmental damage. NXP Semiconductors accepts no liability for inclusion and/or use of NXP Semiconductors products in such equipment or applications and therefore such inclusion and/or use is at the customer's own risk.

**Applications** — Applications that are described herein for any of these products are for illustrative purposes only. NXP Semiconductors makes no representation or warranty that such applications will be suitable for the specified use without further testing or modification.

Customers are responsible for the design and operation of their applications and products using NXP Semiconductors products, and NXP Semiconductors accepts no liability for any assistance with applications or customer product design. It is customer's sole responsibility to determine whether the NXP Semiconductors product is suitable and fit for the customer's applications and products planned, as well as for the planned application and use of customer's third party customer(s). Customers should provide appropriate design and operating safeguards to minimize the risks associated with their applications and products.

NXP Semiconductors does not accept any liability related to any default, damage, costs or problem which is based on any weakness or default in the customer's applications or products, or the application or use by customer's third party customer(s). Customer is responsible for doing all necessary testing for the customer's applications and products using NXP Semiconductors products in order to avoid a default of the applications and the products or of the application or use by customer's third party customer(s). NXP does not accept any liability in this respect.

**Limiting values** — Stress above one or more limiting values (as defined in the Absolute Maximum Ratings System of IEC 60134) will cause permanent damage to the device. Limiting values are stress ratings only and (proper) operation of the device at these or any other conditions above those given in the Recommended operating conditions section (if present) or the Characteristics sections of this document is not warranted. Constant or repeated exposure to limiting values will permanently and irreversibly affect the quality and reliability of the device.

**Terms and conditions of commercial sale** — NXP Semiconductors products are sold subject to the general terms and conditions of commercial sale, as published at <http://www.nxp.com/profile/terms>, unless otherwise agreed in a valid written individual agreement. In case an individual agreement is concluded only the terms and conditions of the respective agreement shall apply. NXP Semiconductors hereby expressly objects to applying the customer's general terms and conditions with regard to the purchase of NXP Semiconductors products by customer.

**No offer to sell or license** — Nothing in this document may be interpreted or construed as an offer to sell products that is open for acceptance or the grant, conveyance or implication of any license under any copyrights, patents or other industrial or intellectual property rights.



**Export control** — This document as well as the item(s) described herein may be subject to export control regulations. Export might require a prior authorization from national authorities.

**Quick reference data** — The Quick reference data is an extract of the product data given in the Limiting values and Characteristics sections of this document, and as such is not complete, exhaustive or legally binding.

## 11.4 Trademarks

Notice: All referenced brands, product names, service names and trademarks are the property of their respective owners.

## 12. Contact information

---

For more information, please visit: <http://www.nxp.com>

For sales office addresses, please send an email to: [salesaddresses@nxp.com](mailto:salesaddresses@nxp.com)

## 13. Contents

---

<b>1</b>	<b>Product profile</b> . . . . .	<b>1</b>
1.1	General description . . . . .	1
1.2	Features and benefits . . . . .	1
1.3	Quick reference data . . . . .	1
<b>2</b>	<b>Pinning information</b> . . . . .	<b>2</b>
<b>3</b>	<b>Ordering information</b> . . . . .	<b>2</b>
<b>4</b>	<b>Circuit diagram</b> . . . . .	<b>2</b>
<b>5</b>	<b>Limiting values</b> . . . . .	<b>3</b>
<b>6</b>	<b>Thermal characteristics</b> . . . . .	<b>3</b>
<b>7</b>	<b>Characteristics</b> . . . . .	<b>4</b>
<b>8</b>	<b>Package outline</b> . . . . .	<b>6</b>
<b>9</b>	<b>Packing information</b> . . . . .	<b>7</b>
<b>10</b>	<b>Revision history</b> . . . . .	<b>7</b>
<b>11</b>	<b>Legal information</b> . . . . .	<b>8</b>
11.1	Data sheet status . . . . .	8
11.2	Definitions . . . . .	8
11.3	Disclaimers . . . . .	8
11.4	Trademarks . . . . .	9
<b>12</b>	<b>Contact information</b> . . . . .	<b>9</b>
<b>13</b>	<b>Contents</b> . . . . .	<b>10</b>

---

Please be aware that important notices concerning this document and the product(s) described herein, have been included in section 'Legal information'.

---

© NXP B.V. 2010.

All rights reserved.

For more information, please visit: <http://www.nxp.com>

For sales office addresses, please send an email to: [salesaddresses@nxp.com](mailto:salesaddresses@nxp.com)

Date of release: 18 November 2010

Document identifier: KMZ41