

# ③ USB 2.0 COMPLIANT

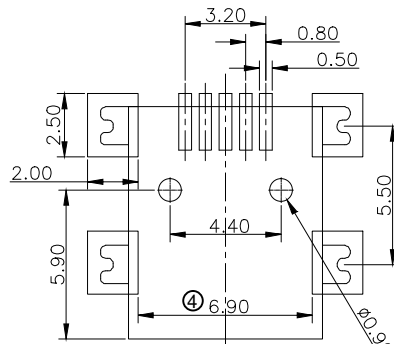
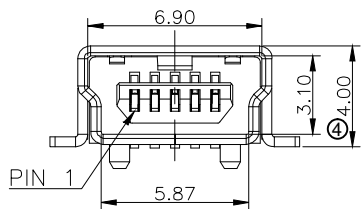
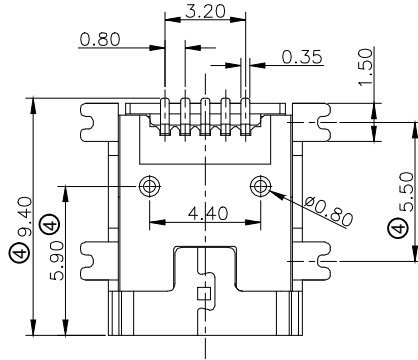
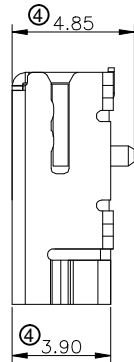
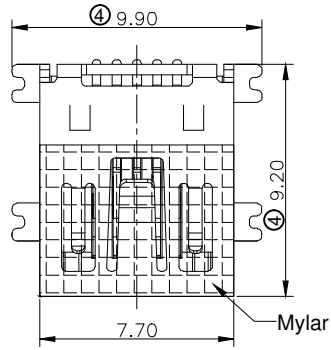

Recommended P.C.Board Layout  
(Tolerance:±0.05)

## ④ NOTES:

### ④1. MATERIAL:

- 1.1 Housing: LCP+30%GF UL94V-0, Color Black
- 1.2 Contact : C5191-EH, T=0.25mm
- 1.3 Shell: C2680R-H, T=0.40mm

### 2. FINISH:

#### 2.1 Contact:

- Contact Area: Selective 30u"Au
- Solder Area: 100u" MIN Tin Plated
- Under Plate: 50u" MIN Ni Plated

#### 2.2 Shell: Ni Plated

### ④ 3. MECHANICAL:

- 3.1 Mating Force: 3.57 kgf MAX
- 3.2 Unmating Force: 0.3 kgf MIN
- 3.3 Durability: 5000 Cycles MIN

### ④ 4. ELECTRICAL:

- ⑥ 4.1 Current Rating: 1.8A Max
- 4.2 Dielectric Strength: 100V AC For 1 Minute
- 4.3 Contact Resistance: 50mΩ MAX
- 4.4 Insulation Resistance: 100MΩ MIN

#### ⑤ 4.5 Voltage Rating: 30VAC

### ④ 5. OPERATING TEMPERATURE: -55°C To +85°C.

### ⑤④ 6. SOLDERING TEMPERATURE: +255°C±5°C for 3~5 S

PACKING: Tape&Reel+mylar

**RoHS compliant**  
Unit: mm

| Scale            | Free  | ⑥   | Update current rating   | 12.05.2020 | Luca   |          | Date       | Name | Customer-No.                               |       |
|------------------|-------|-----|-------------------------|------------|--------|----------|------------|------|--|-------|
| <b>TOLERANCE</b> |       |     |                         |            |        |          |            |      |  |       |
| .X               | ±0.30 | ⑤   | Update                  | 31.10.2019 | Carson | Drawn    | 25.03.2006 | Alex | ASSMANN WSW-No.<br><b>A-USB B-M5-SMD-C</b> |       |
| .XX              | ±0.20 | ④   | Update                  | 23.05.2018 | Segal  | Approved | 12.05.2020 | Luca |  |       |
| .XXX             | ±0.10 | ③   | Add "USB 2.0 COMPLIANT" | 19.08.2013 | Amy    |          |            |      |  |       |
| DIM              | TOL   | ②   | Update                  | 07.07.2009 | Dean   |          |            |      | Drawing-No.                                |       |
| X.°              | ±5°   | ①   | Drawn                   | 25.03.2006 | Alex   |          |            |      | ASS 1456D CO                               | rev06 |
| .X°              | ±3°   | ①   | Drawn                   | 25.03.2006 | Alex   |          |            |      | Replace                                    | SHEET |
| Angle            | TOL   | Id. | Modification            | Date       | Name   |          |            |      |  |       |

# USB 2.0 COMPLIANT

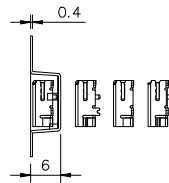
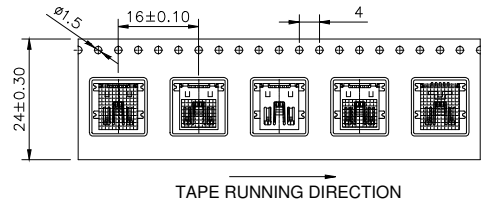

| ITEM | DESCRIPTION            | QTY | UNIT |
|------|------------------------|-----|------|
| 6    | WATERPROOF BAG         | 1   | PCS  |
| 5    | PAPER CORNER PROTECTOR | 4   | PCS  |
| 4    | SHIPPING LABEL         | 1   | PCS  |
| 3    | CARTON                 | 1   | PCS  |
| 2    | DESCCANT               | 4   | PCS  |
| 1    | REEL                   | 10  | SET  |

**Notes:**

- Quantity: 750 PCS/Reel/10 Reels/7.5K PCS/Carton. If the order or mantissa less than 5pcs, can reasonable select carton size.
- 4 bags desiccant/Carton.
- The carton sealed with scotch tape, and attach shipping label on the side.
- Carton size: A=A 35.5X35X33.5 cm, Reel size: Ø330X29 mm.

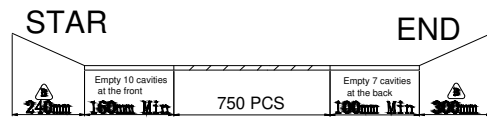
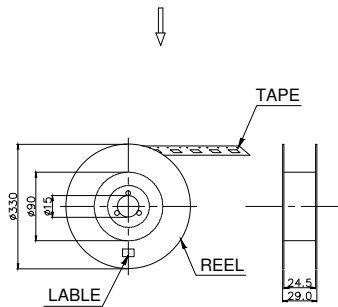

USER DIRECTION OF FEED

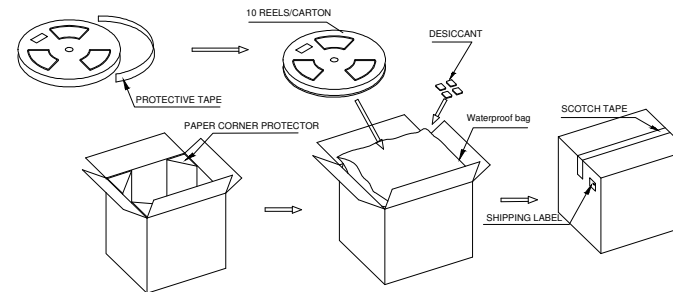

**RoHS compliant**  
Unit: mm

| Scale     | Free  | ⑥   | Update current rating   | 12.05.2020 | Luca   |          | Date       | Name | Customer-No.                               |       |
|-----------|-------|-----|-------------------------|------------|--------|----------|------------|------|--|-------|
| TOLERANCE |       | ⑤   | Update                  | 31.10.2019 | Carson | Drawn    | 25.03.2006 | Alex | ASSMANN WSW-No.<br><b>A-USB B-M5-SMD-C</b> |       |
| .X        | ±0.30 | ④   | Update                  | 23.05.2018 | Segal  | Approved | 12.05.2020 | Luca |  |       |
| .XX       | ±0.20 | ③   | Add "USB 2.0 COMPLIANT" | 19.08.2013 | Amy    |          |            |      |  |       |
| .XXX      | ±0.10 | ②   | Update                  | 07.07.2009 | Dean   |          |            |      | Drawing-No.                                |       |
| DIM       | TOL   | ①   | Drawn                   | 25.03.2006 | Alex   |          |            |      | ASS 1456D CO                               | rev06 |
| X.°       | ±5°   | Id. | Modification            | Date       | Name   |          |            |      | Replace                                    | SHEET |
| .X°       | ±3°   |     |                         |            |        |          |            |      |  |       |
| Angle     | TOL   |     |                         |            |        |          |            |      |  |       |

1

2

3

4

5

6

7