

Click [here](#) for production status of specific part numbers.

## MAX9218

## 27-Bit, 7MHz-to-35MHz DC-Balanced LVDS Deserializer

### General Description

The MAX9218 digital video serial-to-parallel converter deserializes a total of 27 bits during data and control phases. In the data phase, the LVDS serial input is converted to 18 bits of parallel video data and in the control phase, the input is converted to 9 bits of parallel control data. The separate video and control phases take advantage of video timing to reduce the serial data rate. The MAX9218 pairs with the MAX9217 serializer to form a complete digital video transmission system.

Proprietary data decoding reduces EMI and provides DC balance. The DC balance allows AC coupling, providing isolation between the transmitting and receiving ends of the interface. The MAX9218 features a selectable rising or falling output latch edge.

ESD tolerance is specified for ISO 10605 with  $\pm 10\text{kV}$  contact discharge and  $\pm 30\text{kV}$  air discharge.

The MAX9218 operates from a +3.3V core supply and features a separate output supply for interfacing to 1.8V to 3.3V logic-level inputs. This device is available in 48-lead Thin QFN and LQFP packages and is specified from  $-40^\circ\text{C}$  to  $+85^\circ\text{C}$ .

### Applications

- Navigation System Display
- In-Vehicle Entertainment System
- Video Camera
- LCD Displays

### Pin Configurations

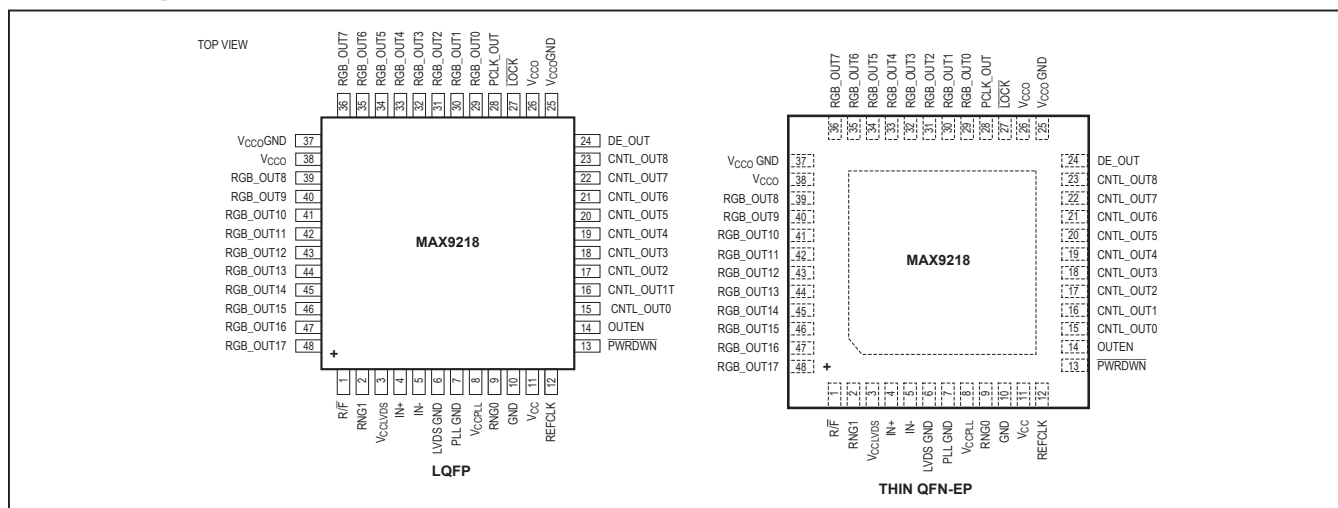

### Features

- Proprietary Data Decoding for DC Balance and Reduced EMI
- Control Data Deserialized During Video Blanking
- Five Control Data Inputs Are Single Bit-Error Tolerant
- Output Transition Time Is Scaled to Operating Frequency for Reduced EMI
- Staggered Output Switching Reduces EMI
- Output Enable Allows Busing of Outputs
- Clock Pulse Stretch on Lock
- Wide  $\pm 2\%$  Reference Clock Tolerance
- Synchronizes to MAX9217 Serializer Without External Control
- ISO 10605 ESD Protection
- Separate Output Supply Allows Interface to 1.8V to 3.3V Logic
- +3.3V Core Power Supply
- Space-Saving Thin QFN and LQFP Packages
- $-40^\circ\text{C}$  to  $+85^\circ\text{C}$  Operating Temperature

**Ordering Information** appears at end of data sheet.

**Absolute Maximum Ratings**

V<sub>CC</sub> to GND.....-0.5V to +4.0V  
 Any Ground to Any Ground.....-0.5V to +0.5V  
 IN+, IN- to LVDS GND.....-0.5V to +4.0V  
 IN+, IN- Short Circuit to LVDS GND or V<sub>CC</sub>LVDS.....Continuous  
 IN+, IN- Short Through 0.125µF (or smaller),  
 25V Series Capacitor.....-0.5V to +16V  
 (R/F, OUTEN, RNG\_, REFCLK,  
 PWRDWN) to GND .....-0.5V to (V<sub>CC</sub> + 0.5V)  
 (RGB\_OUT[17:0], CNTL\_OUT[8:0], DE\_OUT, PCLK\_OUT,  
 LOCK) to V<sub>CCO</sub> GND .....-0.5V to (V<sub>CCO</sub> + 0.5V)  
 Continuous Power Dissipation (T<sub>A</sub> = +70°C)  
 48-Lead LQFP (derate 21.7mW/°C above +70°C)....1739mW  
 48-Lead Thin QFN (derate 37mW/°C above +70°C) 2963mW

ESD Protection  
 Machine Model (R<sub>D</sub> = 0Ω, C<sub>S</sub> = 200pF)  
 All Pins to GND .....±200V  
 Human Body Model (R<sub>D</sub> = 1.5kΩ, C<sub>S</sub> = 100pF)  
 All Pins to GND .....±3.0kV  
 ISO 10605 (R<sub>D</sub> = 2kΩ, C<sub>S</sub> = 330pF)  
 Contact Discharge (IN+, IN-) to GND.....±10kV  
 Air Discharge (IN+, IN-) to GND.....±30kV  
 Storage Temperature Range.....-65°C to +150°C  
 Junction Temperature.....+150°C  
 Lead Temperature (soldering, 10s).....+300°C

Stresses beyond those listed under "Absolute Maximum Ratings" may cause permanent damage to the device. These are stress ratings only, and functional operation of the device at these or any other conditions beyond those indicated in the operational sections of the specifications is not implied. Exposure to absolute maximum rating conditions for extended periods may affect device reliability.

**DC Electrical Characteristics**

(V<sub>CC</sub> = +3.0V to +3.6V, PWRDWN = high, differential input voltage |V<sub>ID</sub>| = 0.05V to 1.2V, input common-mode voltage V<sub>CM</sub> = |V<sub>ID</sub>/2| to V<sub>CC</sub> - |V<sub>ID</sub>/2|, T<sub>A</sub> = -40°C to +85°C, unless otherwise noted. Typical values are at V<sub>CC</sub> = +3.3V, |V<sub>ID</sub>| = 0.2V, V<sub>CM</sub> = 1.2V, T<sub>A</sub> = +25°C.) (Notes 1, 2)

PARAMETER	SYMBOL	CONDITIONS	MIN	TYP	MAX	UNITS
<b>SINGLE-ENDED INPUTS (R/F, OUTEN, RNG0, RNG1, REFCLK, PWRDWN)</b>						
High-Level Input Voltage	V <sub>IH</sub>		2.0		V <sub>CC</sub> + 0.3	V
Low-Level Input Voltage	V <sub>IL</sub>		-0.3		+0.8	V
Input Current	I <sub>IN</sub>	V <sub>IN</sub> = -0.3V to (V <sub>CC</sub> + 0.3V), PWRDWN = high or low	-70		+70	µA
Input Clamp Voltage	V <sub>CL</sub>	I <sub>CL</sub> = -18mA			-1.5	V
<b>SINGLE-ENDED OUTPUTS (RGB_OUT[17:0], CNTL_OUT[8:0], DE_OUT, PCLK_OUT, LOCK)</b>						
High-Level Output Voltage	V <sub>OH</sub>	I <sub>OH</sub> = -100µA	V <sub>CCO</sub> - 0.1		V	
		I <sub>OH</sub> = -2mA, RNG1, RNG0 = high	V <sub>CCO</sub> - 0.35			
		I <sub>OH</sub> = -2mA, RNG1, RNG0 both not high simultaneously	V <sub>CCO</sub> - 0.4			
Low-Level Output Voltage	V <sub>OL</sub>	I <sub>OL</sub> = 100µA	0.1		V	
		I <sub>OL</sub> = 2mA, RNG1, RNG0 = high	0.3			
		I <sub>OL</sub> = 2mA, RNG1, RNG0 both not high simultaneously	0.35			
High-Impedance Output Current	I <sub>OZ</sub>	PWRDWN = low or OUTEN = low, V <sub>O</sub> = -0.3V to V <sub>CCO</sub> + 0.3V	-10		+10	µA

**DC Electrical Characteristics (continued)**

( $V_{CC-} = +3.0V$  to  $+3.6V$ ,  $\overline{PWRDWN} = \text{high}$ , differential input voltage  $|V_{ID}| = 0.05V$  to  $1.2V$ , input common-mode voltage  $V_{CM} = |V_{ID}/2|$  to  $\overline{V_{CC-}} - |V_{ID}/2|$ ,  $T_A = -40^\circ C$  to  $+85^\circ C$ , unless otherwise noted. Typical values are at  $V_{CC-} = +3.3V$ ,  $|V_{ID}| = 0.2V$ ,  $V_{CM} = 1.2V$ ,  $T_A = +25^\circ C$ .) (Notes 1, 2)

PARAMETER	SYMBOL	CONDITIONS	MIN	TYP	MAX	UNITS	
Output Short-Circuit Current	$I_{OS}$	RNG1, RNG0 = high, $V_O = 0$	-10		-50	mA	
		RNG1, RNG0 both not high simultaneously, $V_O = 0$	-7		-40		
<b>LVDS INPUT (IN+, IN-)</b>							
Differential Input High Threshold	$V_{TH}$				50	mV	
Differential Input Low Threshold	$V_{TL}$		-50			mV	
Input Current	$I_{IN+}, I_{IN-}$	$\overline{PWRDWN} = \text{high or low}$	-20		+20	$\mu A$	
Input Bias Resistor	$R_{IB}$	$\overline{PWRDWN} = \text{high or low}$	35	50	65	k $\Omega$	
		$V_{CC-} = 0$ or open, $\overline{PWRDWN} = 0$ or open, Figure 1	35	50	65	k $\Omega$	
Power-Off Input Current	$I_{INO+}, I_{INO-}$	$V_{CC-} = 0$ or open, $\overline{PWRDWN} = 0$ or open	-40		+40	$\mu A$	
<b>POWER SUPPLY</b>							
Worst-Case Supply Current	$I_{CCW}$	$C_L = 8pF$ , worst-case pattern, Figure 2	RNG1 = high, RNG0 = low	7MHz		25	mA
				15MHz		47	
			RNG1 = high, RNG0 = high	15MHz		37	
				35MHz		70	
Power-Down Supply Current	$I_{CCZ}$	(Note 3)			50	$\mu A$	

## AC Electrical Characteristics

( $V_{CC\_}$  = +3.0V to 3.6V,  $C_L$  = 8pF,  $\overline{PWRDWN}$  = high, differential input voltage  $|V_{ID}|$  = 0.1V to 1.2V, input common-mode voltage  $V_{CM} = |V_{ID}/2|$  to  $V_{CC\_} - |V_{ID}/2|$ ,  $T_A$  = -40°C to +85°C, unless otherwise noted. Typical values are at  $V_{CC\_} = +3.3V$ ,  $|V_{ID}| = 0.2V$ ,  $V_{CM} = 1.2V$ ,  $T_A = +25^\circ C$ .) (Notes 4, 5)

PARAMETER	SYMBOL	CONDITIONS	MIN	TYP	MAX	UNITS
<b>REFCLK TIMING REQUIREMENTS</b>						
Period	$t_T$		28.57		333.00	ns
Frequency	$f_{CLK}$		7		35	MHz
Frequency Variation	$\Delta f_{CLK}$	REFCLK to serializer PCLK_IN	-2.0		+2.0	%
Duty Cycle	DC		40	50	60	%
Transition Time	$t_{TRAN}$	20% to 80%			6	ns
<b>SWITCHING CHARACTERISTICS</b>						
Output Rise Time	$t_R$	Figure 3	RNG1, RNG0 = high	3.2	4.4	ns
			RNG1, RNG0 both not high simultaneously	3.8	5.5	
Output Fall Time	$t_F$	Figure 3	RNG1, RNG0 = high	2.7	4.5	ns
			RNG1, RNG0 both not high simultaneously	3.6	5.3	
PCLK_OUT High Time	$t_{HIGH}$	Figure 4	$0.4 \times t_T$	$0.45 \times t_T$	$0.6 \times t_T$	ns
PCLK_OUT Low Time	$t_{LOW}$	Figure 4	$0.4 \times t_T$	$0.45 \times t_T$	$0.6 \times t_T$	ns
Data Valid Before PCLK_OUT	$t_{DVB}$	Figure 5	$0.35 \times t_T$	$0.4 \times t_T$		ns
Data Valid After PCLK_OUT	$t_{DVA}$	Figure 5	$0.35 \times t_T$	$0.4 \times t_T$		ns
Input-to-Output Delay	$t_{DELAY}$	Figure 6	$2.575 \times t_T + 8.5$		$2.725 \times t_T + 12.8$	ns
PLL Lock to REFCLK	$t_{PLLREF}$	Figure 7			$16385 \times t_T$	ns
Power-Down Delay	$t_{PDD}$	Figure 7			100	ns
Output Enable Time	$t_{OE}$	Figure 8			30	ns
Output Disable Time	$t_{OZ}$	Figure 9			30	ns

**Note 1:** Current into a pin is defined as positive. Current out of a pin is defined as negative. All voltages are referenced to ground except  $V_{TH}$  and  $V_{TL}$ .

**Note 2:** Maximum and minimum limits over temperature are guaranteed by design and characterization. Devices are production tested at  $T_A = +25^\circ C$ .

**Note 3:** All LVTTTL/LVCMOS inputs, except  $\overline{PWRDWN}$  at  $\leq 0.3V$  or  $\geq V_{CC\_} - 0.3V$ .  $\overline{PWRDWN}$  is  $\leq 0.3V$ .

**Note 4:** AC parameters are guaranteed by design and characterization, and are not production tested. Limits are set at  $\pm 6$  sigma.

**Note 5:**  $C_L$  includes probe and test jig capacitance.

**Typical Operating Characteristics**

( $V_{CC\_} = +3.3V$ ,  $C_L = 8pF$ ,  $T_A = +25^\circ C$ , unless otherwise noted.)

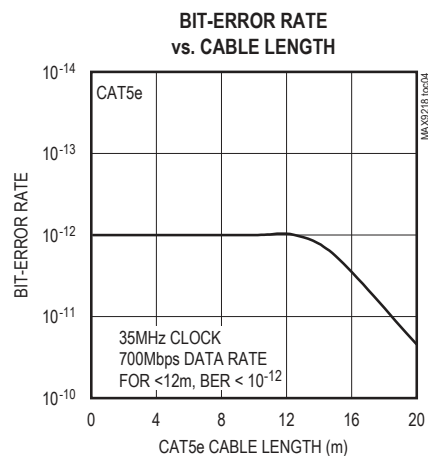
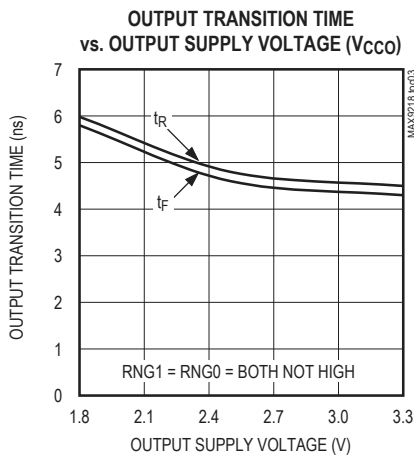
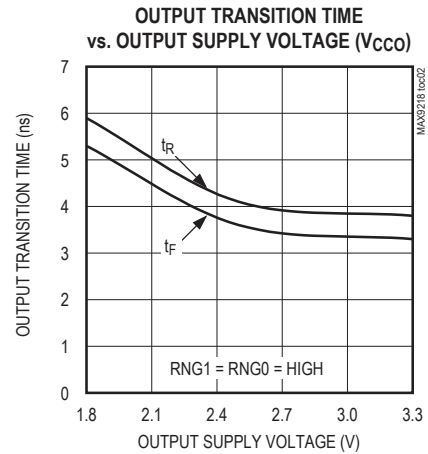
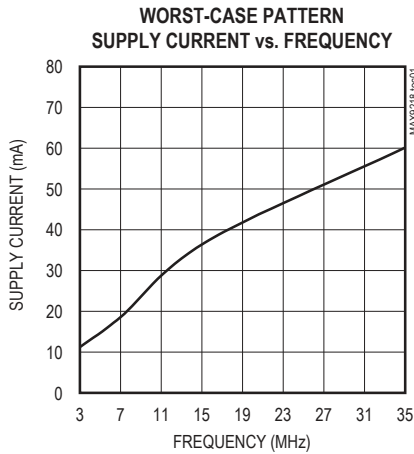

## Pin Description

PIN	NAME	FUNCTION
1	R/ $\bar{F}$	Rising or Falling Latch Edge Select. LVTTTL/LVCMOS input. Selects the edge of PCLK_OUT for latching data into the next chip. Set R/ $\bar{F}$ = high for a rising latch edge. Set R/ $\bar{F}$ = low for a falling latch edge. Internally pulled down to GND.
2	RNG1	LVTTTL/LVCMOS Range Select Input. Set to the range that includes the serializer parallel clock input frequency. Internally pulled down to GND.
3	V <sub>CCLVDS</sub>	LVDS Supply Voltage. Bypass to LVDS GND with 0.1 $\mu$ F and 0.001 $\mu$ F capacitors in parallel as close to the device as possible, with the smallest value capacitor closest to the supply pin.
4	IN+	Noninverting LVDS Serial Data Input
5	IN-	Inverting LVDS Serial Data Input
6	LVDS GND	LVDS Supply Ground
7	PLL GND	PLL Supply Ground
8	V <sub>CCPLL</sub>	PLL Supply Voltage. Bypass to PLL GND with 0.1 $\mu$ F and 0.001 $\mu$ F capacitors in parallel as close to the device as possible, with the smallest value capacitor closest to the supply pin.
9	RNG0	LVTTTL/LVCMOS Range Select Input. Set to the range that includes the serializer parallel clock input frequency. Internal pulldown to GND.
10	GND	Digital Supply Ground
11	V <sub>CC</sub>	Digital Supply Voltage. Supply for LVTTTL/LVCMOS inputs and digital circuits. Bypass to GND with 0.1 $\mu$ F and 0.001 $\mu$ F capacitors in parallel as close to the device as possible, with the smallest value capacitor closest to the supply pin.
12	REFCLK	LVTTTL/LVCMOS Reference Clock Input. Apply a reference clock that is within $\pm 2\%$ of the serializer PCLK_IN frequency. Internally pulled down to GND.
13	$\overline{\text{PWRDWN}}$	LVTTTL/LVCMOS Power-Down Input. Internally pulled down to GND.
14	OUTEN	LVTTTL/LVCMOS Output Enable Input. High activates the single-ended outputs. Driving low places the single-ended outputs in high impedance. Internally pulled down to GND.
15–23	CNTL_OUT [8:0]	LVTTTL/LVCMOS Control Data Outputs. CNTL_OUT[8:0] are latched into the next chip on the rising or falling edge of PCLK_OUT as selected by R/ $\bar{F}$ when DE_OUT is low, and are held at the last state when DE_OUT is high.
24	DE_OUT	LVTTTL/LVCMOS Data Enable Output. High indicates RGB_OUT[17:0] are active. Low indicates CNTL_OUT[8:0] are active.
25, 37	V <sub>CCO</sub> GND	Output Supply Ground
26, 38	V <sub>CCO</sub>	Output Supply Voltage. Bypass to GND with 0.1 $\mu$ F and 0.001 $\mu$ F capacitors in parallel as close to the device as possible, with the smallest value capacitor closest to the supply pin.
27	$\overline{\text{LOCK}}$	LVTTTL/LVCMOS Lock Indicator Output. Outputs are valid when $\overline{\text{LOCK}}$ is low.
28	PCLK_OUT	LVTTTL/LVCMOS Parallel Clock Output. Latches data into the next chip on the edge selected by R/ $\bar{F}$ .
29–36, 39–48	RGB_OUT [17:0]	LVTTTL/LVCMOS Red, Green, and Blue Digital Video Data Outputs. RGB_OUT[17:0] are latched into the next chip on the edge of PCLK_OUT selected by R/ $\bar{F}$ when DE_OUT is high, and are held at the last state when DE_OUT is low.
—	EP	Exposed Pad for Thin QFN Package Only. Connect to GND.

Functional Diagram

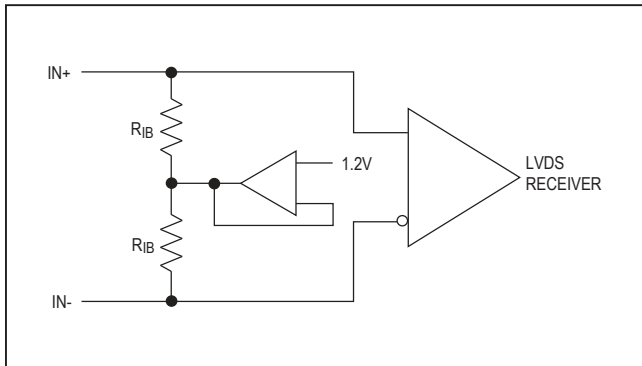
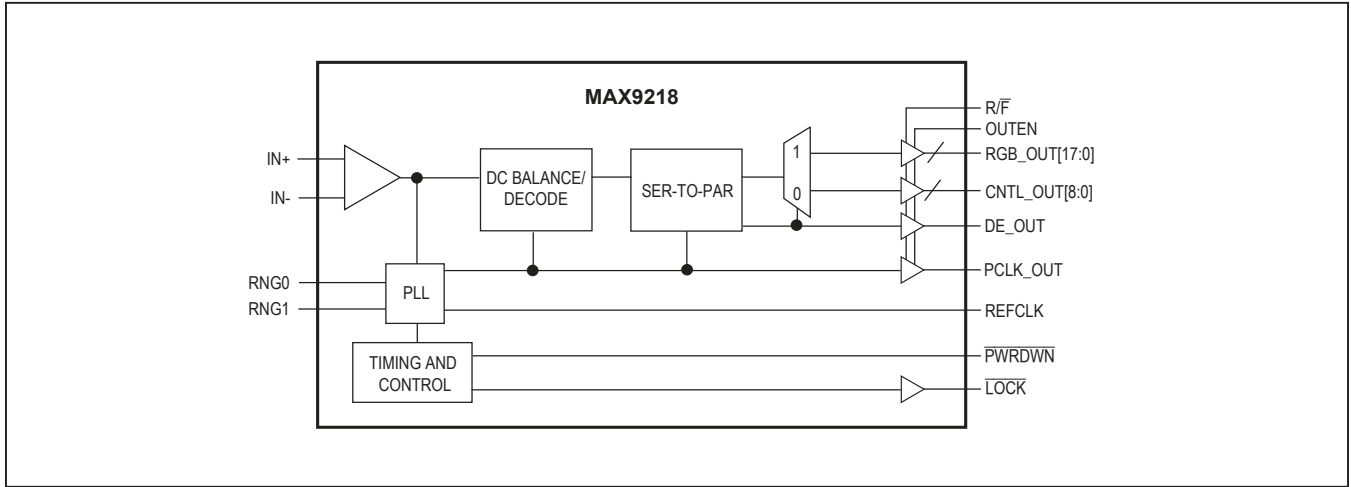

Figure 1. LVDS Input Bias

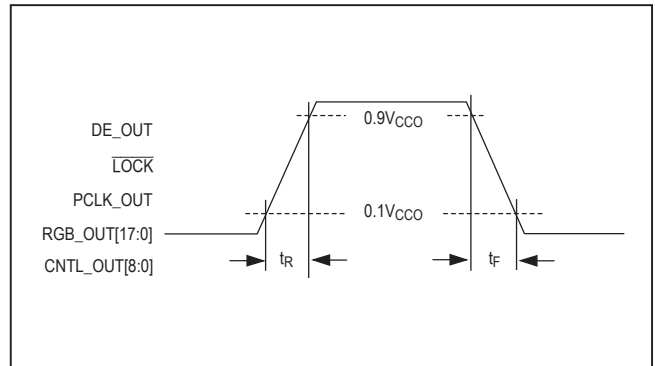

Figure 3. Output Rise and Fall Times

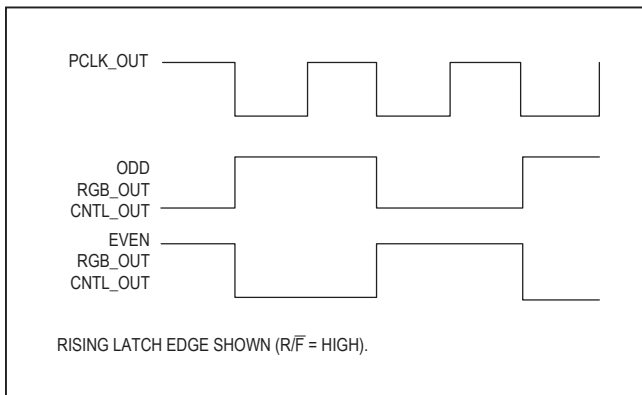

Figure 2. Worst-Case Output Pattern

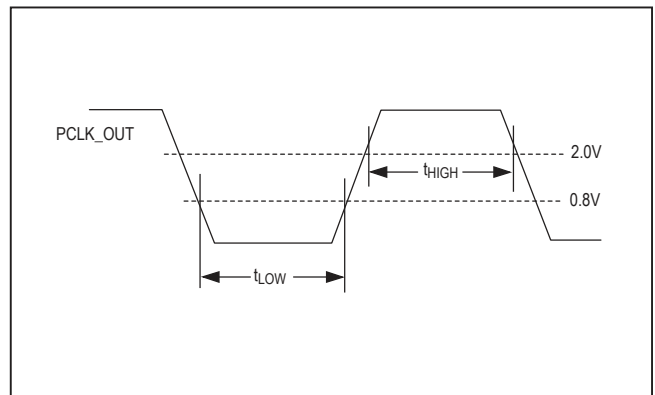

Figure 4. High and Low Times

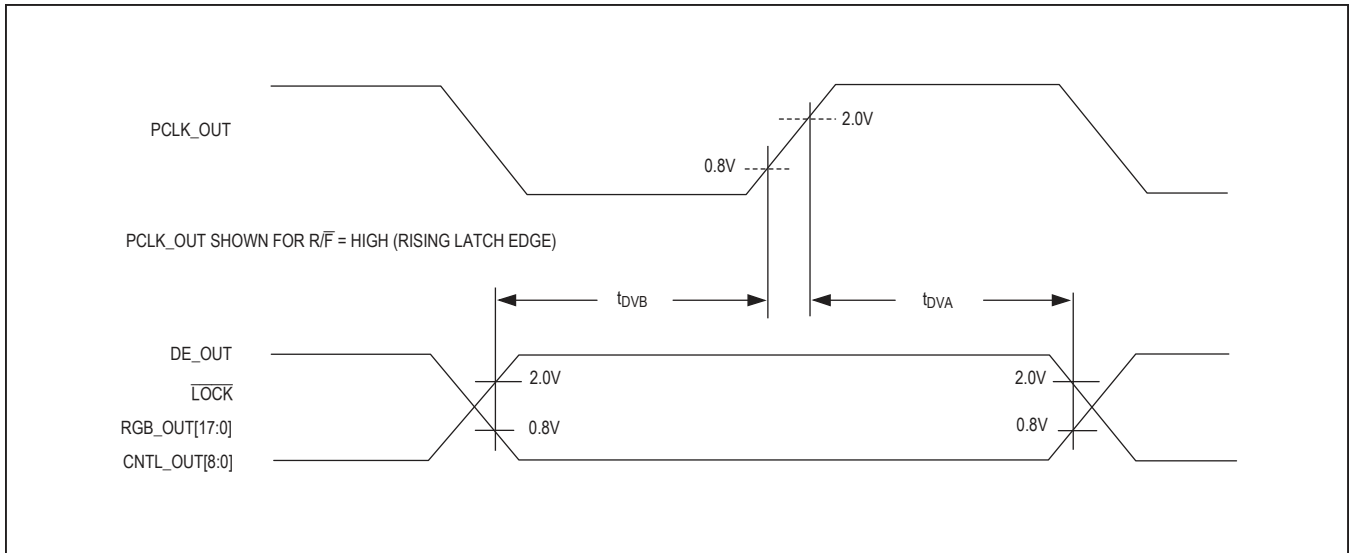

Figure 5. Synchronous Output Timing

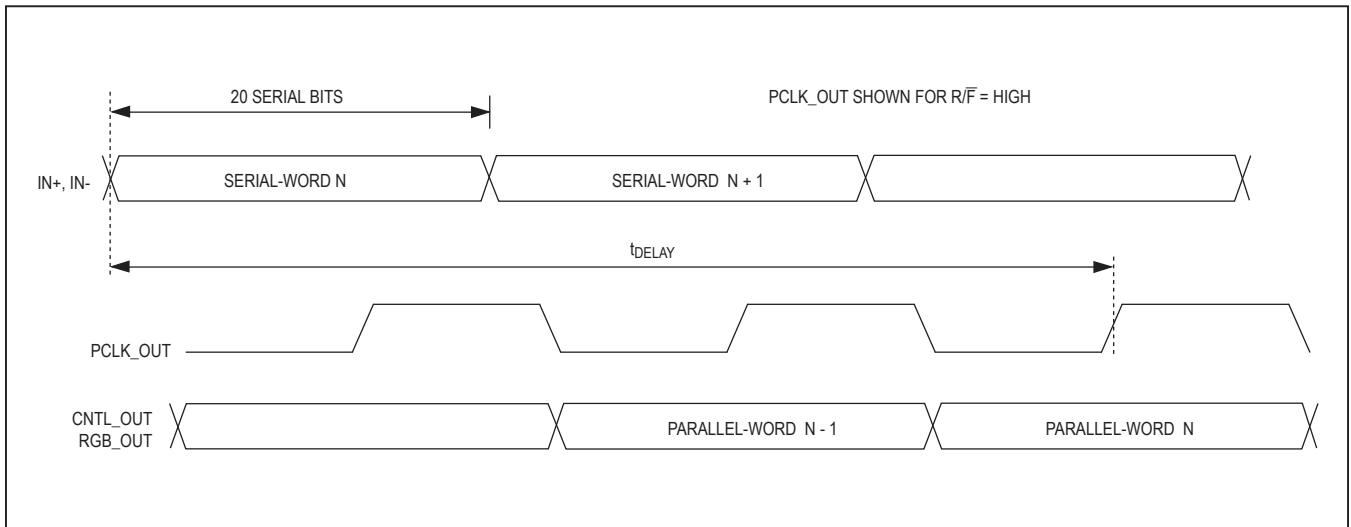

Figure 6. Deserializer Delay



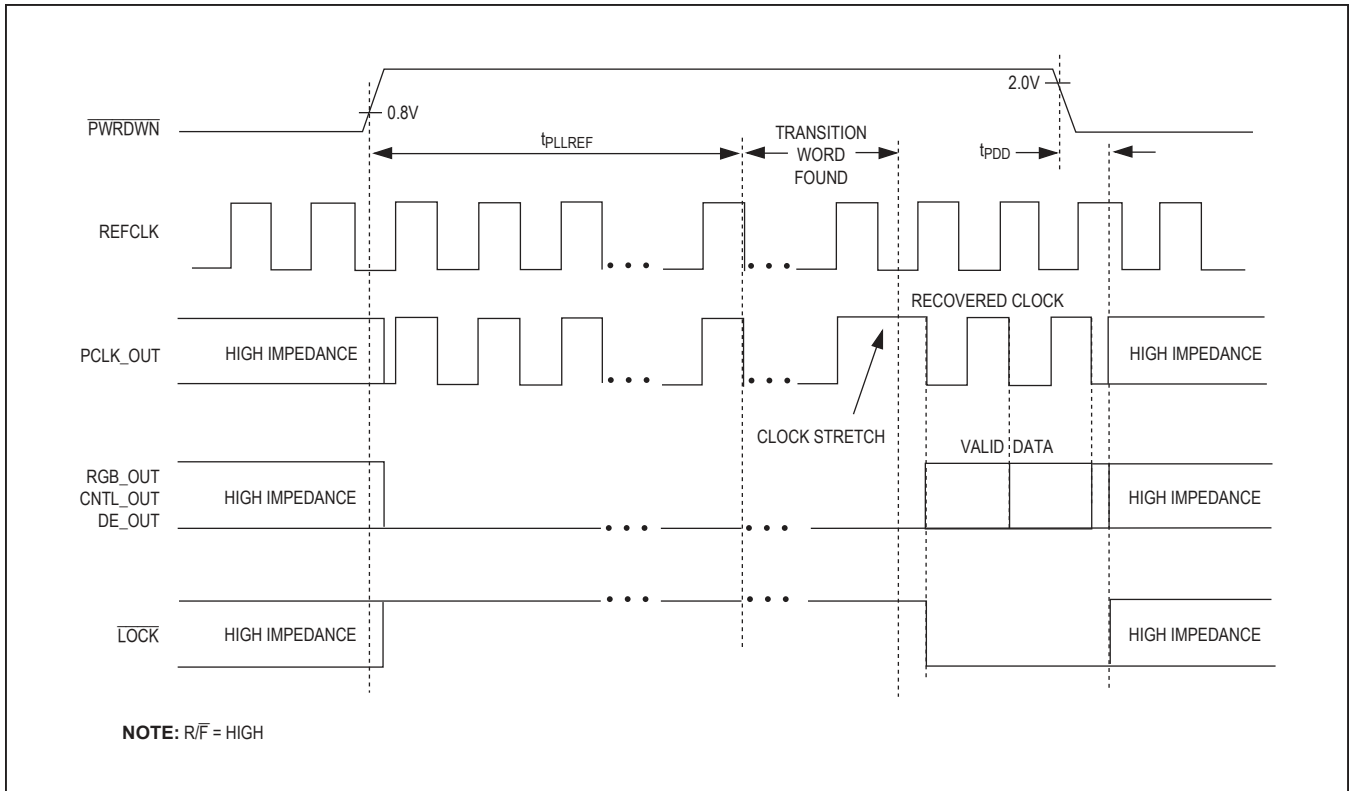

Figure 7. PLL Lock to REFCLK and Power-Down Delay

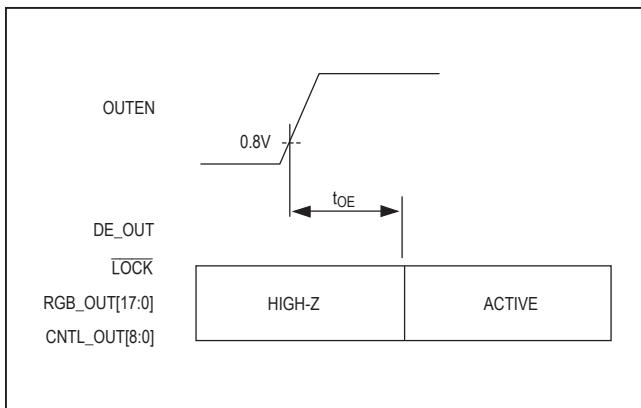

Figure 8. Output Enable Time

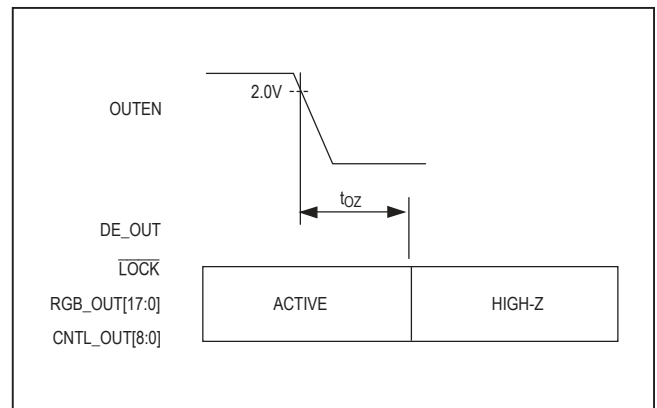

Figure 9. Output Disable Time

## Detailed Description

The MAX9218 DC-balanced deserializer operates at a parallel-clock frequency of 7MHz to 35MHz, deserializing video data to the RGB\_OUT[17:0] outputs when the data enable output DE\_OUT is high, or control data to the CNTL\_OUT[8:0] outputs when DE\_OUT is low. The video phase words are decoded using two overhead bits, EN0 and EN1. Control phase words are decoded with one overhead bit, EN0. Encoding, performed by the MAX9217 serializer, reduces EMI and maintains DC balance across the serial cable. The serial input word formats are shown in Table 1 and Table 2.

Control-data inputs C0 to C4, each repeated over three serial bit times by the serializer, are decoded using majority voting. Two or three bits at the same state determine the state of the recovered bit, providing single bit-error tolerance for C0 to C4. The state of C5 to C8 is determined by the level of the bit itself (no voting is used).

### AC-Coupling Benefits

AC-coupling increases the input voltage of the LVDS receiver to the voltage rating of the capacitor. Two capacitors are sufficient for isolation, but four capacitors—two at the serializer output and two at the deserializer input—provide protection if either end of the cable is shorted to a high voltage. AC-coupling blocks low-frequency ground shifts and common-mode noise. The MAX9217 serializer can also be DC-coupled to the MAX9218 deserializer. Figure 10 is the AC-coupled serializer and deserializer with two capacitors per link, and Figure 11

is the AC-coupled serializer and deserializer with four capacitors per link.

## Applications Information

### Selection of AC-Coupling Capacitors

See Figure 12 for calculating the capacitor values for AC coupling, depending on the parallel clock frequency. The plot shows capacitor values for two- and four-capacitor-per-link systems. For applications using less than 18MHz clock frequency, use 0.1µF capacitors.

### Termination and Input Bias

The IN+ and IN- LVDS inputs are internally connected to +1.2V through 35kΩ (min) to provide biasing for AC coupling (Figure 1). Assuming 100Ω interconnect, the LVDS input can be terminated with a 100Ω resistor. Match the termination to the differential impedance of the interconnect.

Use a Thevenin termination, providing 1.2V bias, on an AC-coupled link in noisy environments. For interconnect with 100Ω differential impedance, pull each LVDS line up to V<sub>CC</sub> with 130Ω and down to ground with 82Ω at the deserializer input (Figure 10 and Figure 11). This termination provides both differential and common-mode termination. The impedance of the Thevenin termination should be half the differential impedance of the interconnect and provide a bias voltage of 1.2V.

**Table 1. Serial Video Phase Word Format**

0	1	2	3	4	5	6	7	8	9	10	11	12	13	14	15	16	17	18	19
EN0	EN1	S0	S1	S2	S3	S4	S5	S6	S7	S8	S9	S10	S11	S12	S13	S14	S15	S16	S17

Bit 0 is the LSB and is deserialized first. EN[1:0] are encoding bits. S[17:0] are encoded symbols.

**Table 2. Serial Control Phase Word Format**

0	1	2	3	4	5	6	7	8	9	10	11	12	13	14	15	16	17	18	19
EN0	C0	C0	C0	C1	C1	C1	C2	C2	C2	C3	C3	C3	C4	C4	C4	C5	C6	C7	C8

Bit 0 is the LSB and is deserialized first. C[8:0] are the mapped control inputs.

# MAX9218

## 27-Bit, 7MHz-to-35MHz DC-Balanced LVDS Deserializer

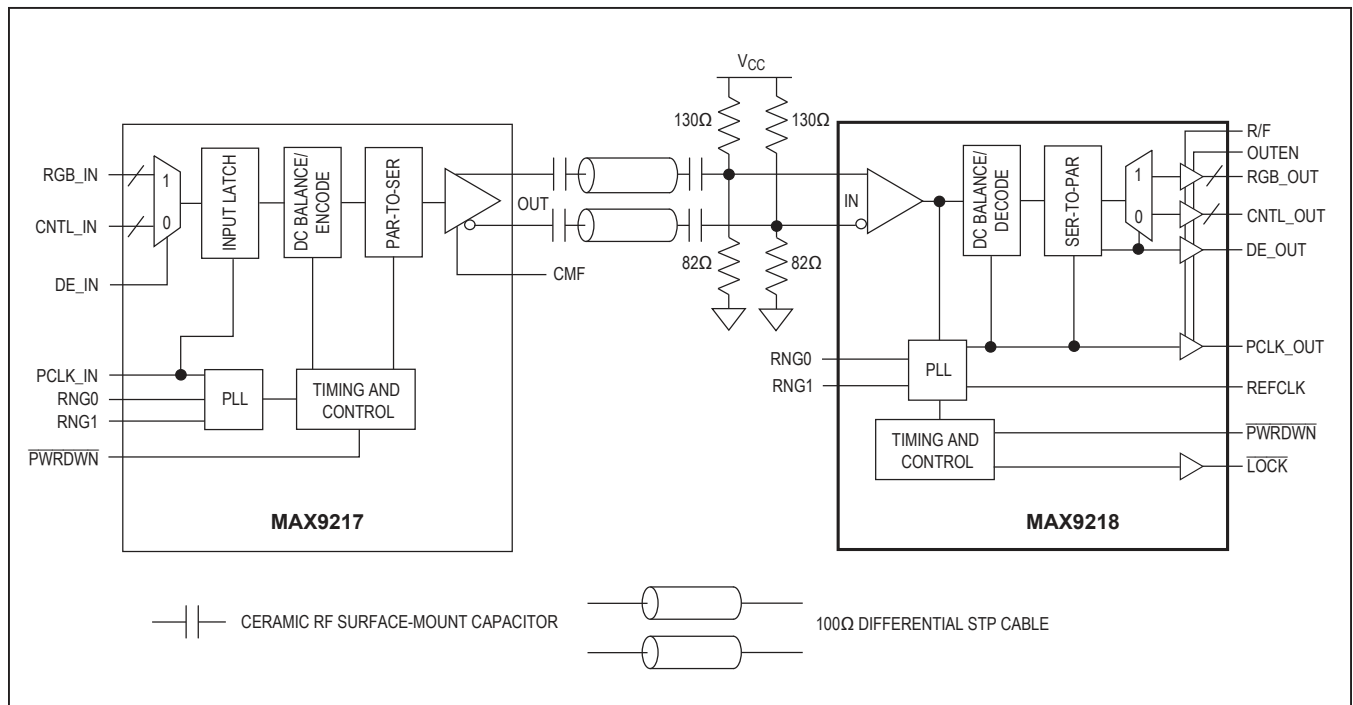
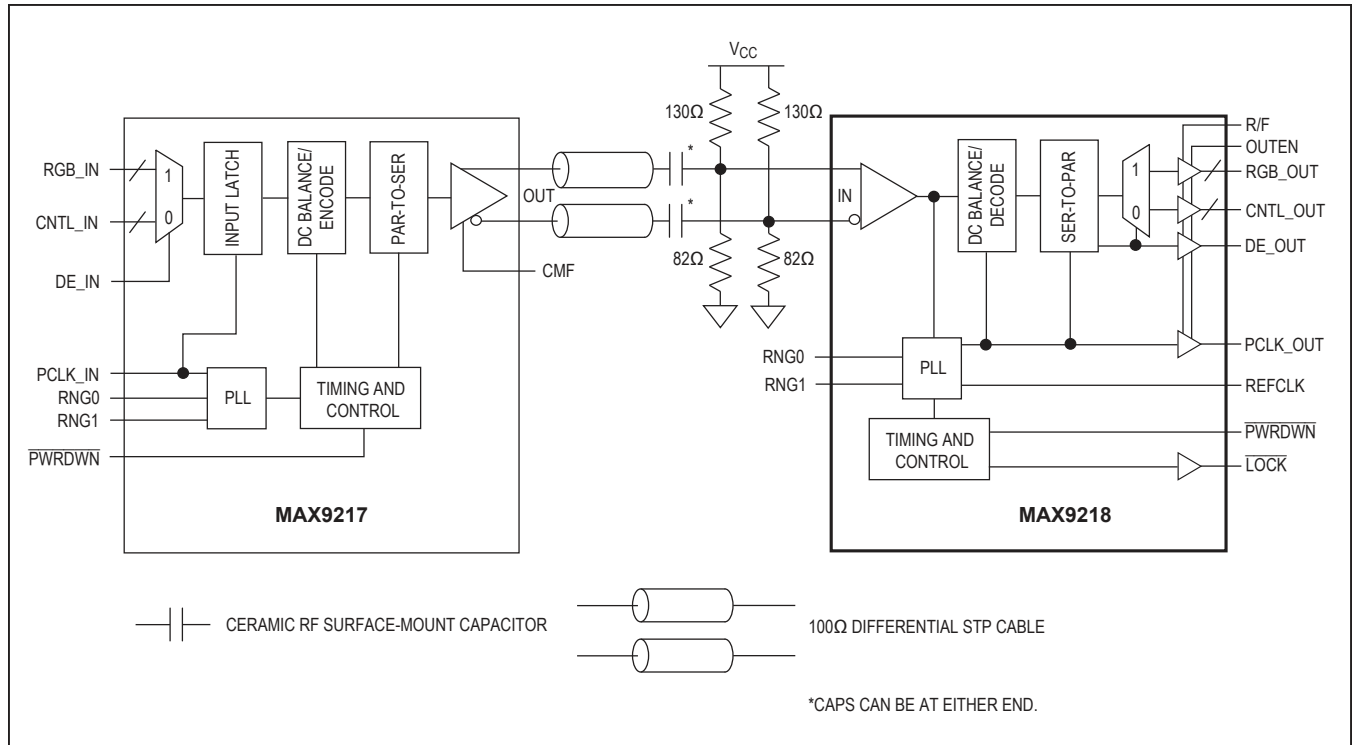

### Input Frequency Detection

A frequency-detection circuit detects when the LVDS input is not switching. When not switching, all outputs except  $\overline{\text{LOCK}}$  are low,  $\overline{\text{LOCK}}$  is high, and PCLK\_OUT follows REFCLK. This condition occurs, for example, if the serializer is not driving the interconnect or if the interconnect is open.

### Frequency Range Setting (RNG[1:0])

The RNG[1:0] inputs select the operating frequency range of the MAX9218 and the transition time of the outputs. Select the frequency range that includes the MAX9217 serializer PCLK\_IN frequency. Table 3 shows the selectable frequency ranges and the corresponding data rates and output transition times.

### Power Down

Driving  $\overline{\text{PWRDWN}}$  low puts the outputs in high impedance and stops the PLL. With  $\overline{\text{PWRDWN}} \leq 0.3\text{V}$  and all LVTTL/LVCMOS inputs  $\leq 0.3\text{V}$  or  $\geq V_{\text{CC}} - 0.3\text{V}$ , the supply current is reduced to less than 50 $\mu\text{A}$ . Driving  $\overline{\text{PWRDWN}}$  high initiates lock to the local reference clock (REFCLK) and afterwards to the serial input.

### Lock and Loss of Lock ( $\overline{\text{LOCK}}$ )

When  $\overline{\text{PWRDWN}}$  is driven high, the PLL begins locking to REFCLK, drives  $\overline{\text{LOCK}}$  from high impedance to high and the other outputs from high impedance to low except PCLK\_OUT. PCLK\_OUT outputs REFCLK while the PLL is locking to REFCLK. Locking to REFCLK takes a maximum of 16,385 REFCLK cycles. When locking to REFCLK is complete, the serial input is monitored for a transition word. When a transition word is found,  $\overline{\text{LOCK}}$  is driven low indicating valid output data, and the parallel rate clock recovered from the serial input is output on PCLK\_OUT. PCLK\_OUT is stretched on the change from REFCLK to recovered clock (or vice versa).

**Table 3. Frequency Range Programming**

RNG1	RNG0	PARALLEL CLOCK (MHz)	SERIAL DATA RATE (Mbps)	OUTPUT TRANSITION TIME
0	0	Do not use		
0	1			
1	0	7 to 15	140 to 300	Slow
1	1	15 to 35	300 to 700	Fast

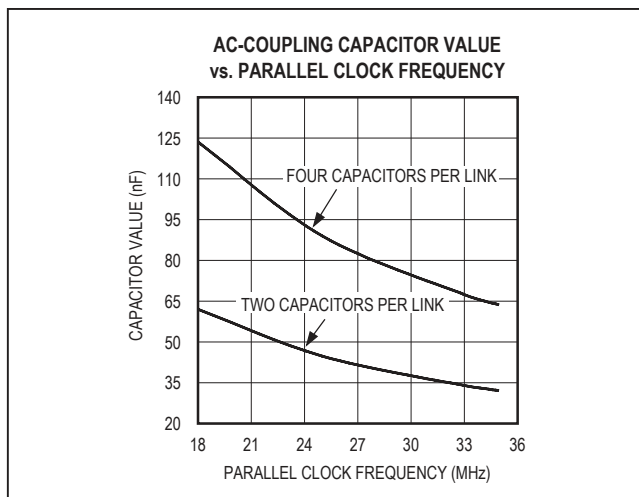

Figure 12. AC-Coupling Capacitor Values vs. Clock Frequency of 18MHz to 35MHz

If a transition word is not detected within 2<sup>20</sup> cycles of PCLK\_OUT,  $\overline{\text{LOCK}}$  is driven high and the other outputs except PCLK\_OUT are driven low. REFCLK is output on PCLK\_OUT and the deserializer continues monitoring the serial input for a transition word. See Figure 7 for the synchronization timing diagram.

### Output Enable (OUTEN) and Busing Outputs

The outputs of two MAX9218s can be used to form a 2:1 mux with the outputs controlled by the output enable. Wait 30ns between disabling one deserializer (driving OUTEN low) and enabling the second one (driving OUTEN high) to avoid contention of the bused outputs. OUTEN controls all outputs.

### Rising or Falling Output Latch Edge (R/ $\overline{\text{F}}$ )

The MAX9218 has a selectable rising or falling output latch edge through a logic setting on R/ $\overline{\text{F}}$ . Driving R/ $\overline{\text{F}}$  high selects the rising output latch edge, which latches the parallel output data into the next chip on the rising edge of PCLK\_OUT. Driving R/ $\overline{\text{F}}$  low selects the falling output latch edge, which latches the parallel output data into the next chip on the falling edge of PCLK\_OUT. The MAX9218 output-latch-edge polarity does not need to match the MAX9217 serializer input-latch-edge polarity. Select the latch-edge polarity required by the chip being driven by the MAX9218.

**Staggered and Transition Time Adjusted Outputs**

RGB\_OUT[17:0] are grouped into three groups of six, with each group switching about 1ns apart in the video phase to reduce EMI and ground bounce.

CNTL\_OUT[8:0] switch during the control phase. Output transition times are slower in the 7MHz-to-15MHz range and faster in the 15MHz-to-35MHz range.

**Data Enable Output (DE\_OUT)**

The MAX9218 deserializes video and control data at different times. Control data is deserialized during the video blanking time. DE\_OUT high indicates that video data is being deserialized and output on RGB\_OUT[17:0]. DE\_OUT low indicates that control data is being deserialized and output on CNTL\_OUT[8:0]. When outputs are not being updated, the last data received is latched on the outputs. Figure 13 shows the DE\_OUT timing.

**Power-Supply Circuits and Bypassing**

There are separate on-chip power domains for digital circuits and LVTTTL/LVCMOS inputs (V<sub>CC</sub> supply and GND), outputs (V<sub>CCO</sub> supply and V<sub>CCO</sub> GND), PLL (V<sub>CCPLL</sub> supply and V<sub>CCPLL</sub> GND), and the LVDS input (V<sub>CCLVDS</sub>

supply and V<sub>CCLVDS</sub> GND). The grounds are isolated by diode connections. Bypass each V<sub>CC</sub>, V<sub>CCO</sub>, V<sub>CCPLL</sub>, and V<sub>CCLVDS</sub> pin with high-frequency, surface-mount ceramic 0.1μF and 0.001μF capacitors in parallel as close to the device as possible, with the smallest value capacitor closest to the supply pin. The outputs are powered from V<sub>CCO</sub>, which accepts a 1.71V to 3.6V supply, allowing direct interface to inputs with 1.8V to 3.3V logic levels.

**Cables and Connectors**

Interconnect for LVDS typically has a differential impedance of 100Ω. Use cables and connectors that have matched differential impedance to minimize impedance discontinuities.

Twisted-pair and shielded twisted-pair cables offer superior signal quality compared to ribbon cable and tend to generate less EMI due to magnetic field canceling effects. Balanced cables pick up noise as common mode, which is rejected by the LVDS receiver.

**Board Layout**

Separate the LVTTTL/LVCMOS outputs and LVDS inputs to prevent crosstalk. A four-layer PCB with separate layers for power, ground, and signals is recommended.

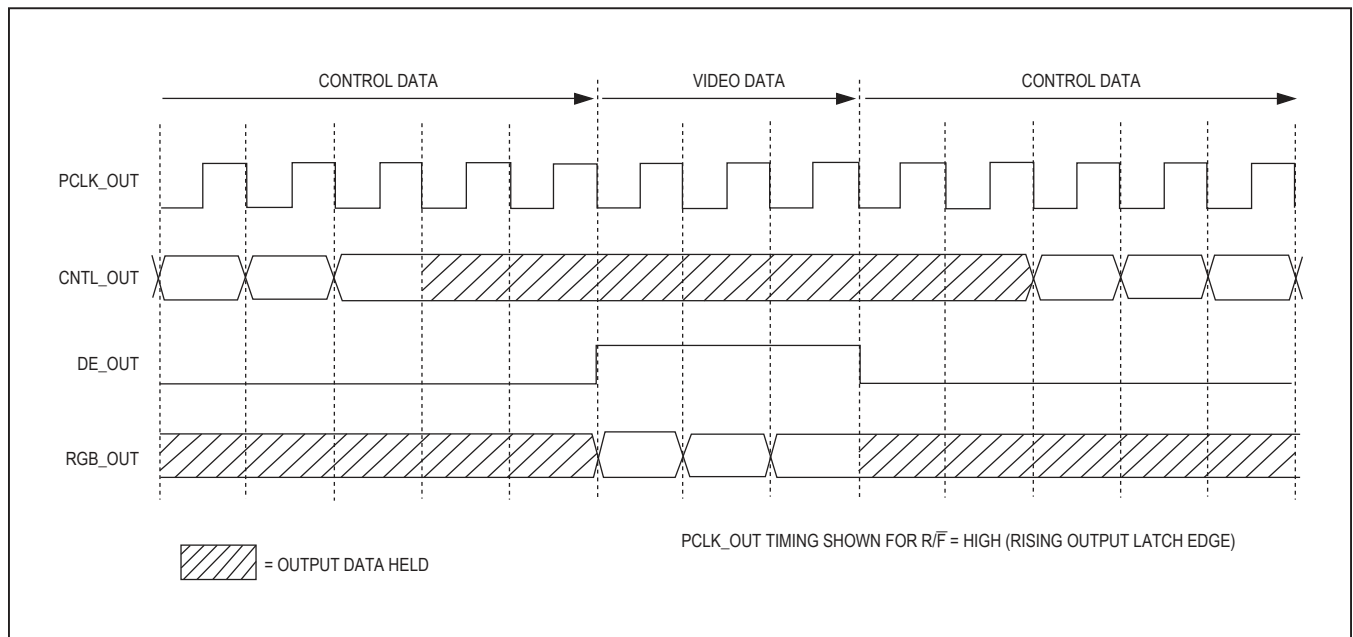

Figure 13. Output Timing

**ESD Protection**

The MAX9218 ESD tolerance is rated for the Human Body Model, Machine Model, and ISO 10605. ISO 10605 specifies ESD tolerance for electronic systems.

The Human Body Model discharge components are  $C_S = 100\text{pF}$  and  $R_D = 1.5\text{k}\Omega$  (Figure 14). The ISO 10605 discharge components are  $C_S = 330\text{pF}$  and  $R_D = 2\text{k}\Omega$  (Figure 15). The Machine Model discharge components are  $C_S = 200\text{pF}$  and  $R_D = 0\Omega$  (Figure 16).

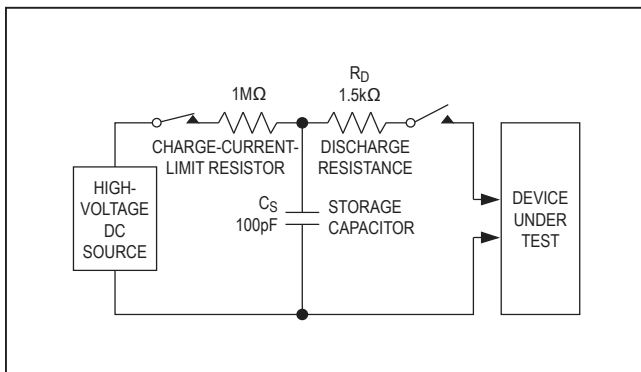

Figure 14. Human Body ESD Test Circuit

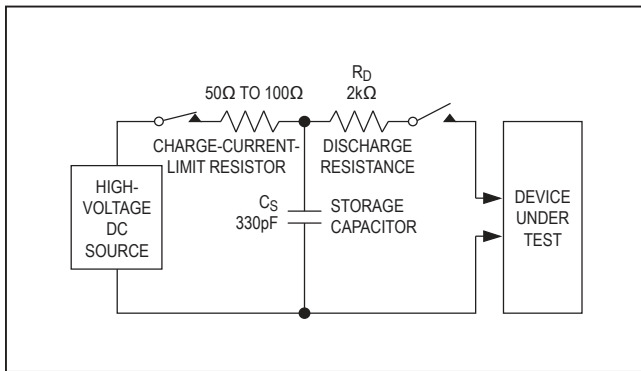

Figure 15. ISO 10605 Contact Discharge ESD Test Circuit

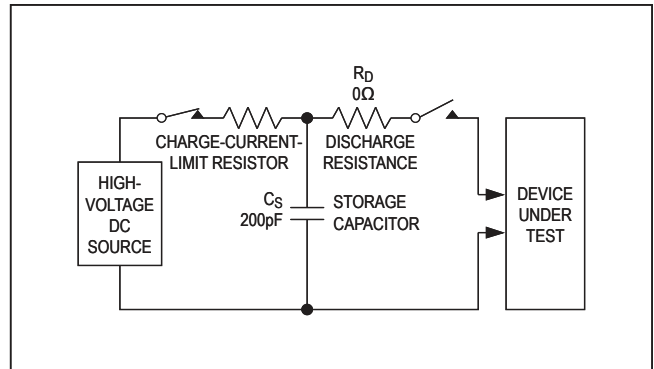

Figure 16. Machine Model ESD Test Circuit.

**Chip Information**

PROCESS: CMOS

**Ordering Information**

PART	TEMP RANGE	PIN-PACKAGE
MAX9218ECM+	-40°C to +85°C	48 LQFP
MAX9218ECM/V+	-40°C to +85°C	48 LQFP
MAX9218ETM+	-40°C to +85°C	48 Thin QFN-EP*

+Denotes a lead(Pb)-free/RoHS-compliant package.

V denotes an automotive qualified part.

\*EP = Exposed pad.

**Package Information**

For the latest package outline information and land patterns (footprints), go to [www.maximintegrated.com/packages](http://www.maximintegrated.com/packages). Note that a "+", "#", or "-" in the package code indicates RoHS status only. Package drawings may show a different suffix character, but the drawing pertains to the package regardless of RoHS status.

PACKAGE TYPE	PACKAGE CODE	DOCUMENT NO.
48 LQFP	C48+5	<a href="#">21-0054</a>
48 TQFN	T4866+1	<a href="#">21-0141</a>

## Revision History

REVISION NUMBER	REVISION DATE	DESCRIPTION	PAGES CHANGED
3	2/08	Corrected typo (REF_IN should be REFCLK) in Figure 11	11
4	5/08	Corrected LQFP package, added Machine Model ESD, and corrected diagrams	1, 2, 6, 7, 10, 11, 14-18
5	8/09	Added automotive qualified part to Ordering Information	1
6	1/19	Removed all reference to 3MHz-7MHz operation in <a href="#">DC Electrical Characteristics</a> , <a href="#">AC Electrical Characteristics</a> , <a href="#">Detailed Description</a> , <a href="#">Applications Information</a> , and <a href="#">Table 3</a>	3, 4, 10, 12, 13

For pricing, delivery, and ordering information, please visit Maxim Integrated's online storefront at <https://www.maximintegrated.com/en/storefront/storefront.html>.

Maxim Integrated cannot assume responsibility for use of any circuitry other than circuitry entirely embodied in a Maxim Integrated product. No circuit patent licenses are implied. Maxim Integrated reserves the right to change the circuitry and specifications without notice at any time. The parametric values (min and max limits) shown in the Electrical Characteristics table are guaranteed. Other parametric values quoted in this data sheet are provided for guidance.