

3.15A USB Type-C Autonomous Charger with JEITA for 1-Cell Li-ion/LiFePO₄ Batteries

MAX77787

General Description

The MAX77787 is a standalone, 3.15A charger with integrated USB Type-C[®] CC detection and reverse-boost capability. The fast-charge current and termination voltage is easily configured with resistors. The IC operates with an input voltage of 4.5V to 13.4V and has a maximum input current limit of 3A. The IC also implements the adaptive input current limit (AICL) function that regulates the input voltage by reducing input current to prevent the voltage of a weak adapter from collapsing or folding back.

The USB Type-C Configuration Channel (CC) detection pins on the IC enable automatic USB Type-C power source detection and input current limit configuration without any software control as soon as the USB plug is inserted. The IC also integrates BC1.2 and proprietary adapter detection using the D+ and D- pins.

The IC offers reverse-boost capability up to 5.1V, 1.5A, that can be enabled with the ENBST pin, also BYP reverse-boost that can be enabled with the ENBST and STBY pin combination. The STAT pin indicates charging status, while the INOKB pin indicates valid input voltage. Charging can be stopped by pulling the CHGENB pin low.

The IC is equipped with a Smart Power Selector™ and a battery true-disconnect FET to control the charging and discharging of the battery or isolate the battery in case of a fault. The IC supports Li-ion batteries with JEITA compliance. It also has another option that supports LiFePO₄ batteries with non-JEITA compliance. The IC comes in a 2.758mm x 2.758mm, 0.4mm pitch, 6 x 6 wafer-level package (WLP) making it suitable for low-cost PCB assembly.

Applications

- Mobile Point-of-Sale (mPOS) Terminals
- Portable Medical Devices
- Wireless Headphones
- GPS Trackers
- Charging Cradles for Wearable Devices
- Power Banks
- Mobile Routers

USB Type-C is a registered trademark of USB Implementers Forum.

Smart Power Selector is a trademark of Maxim Integrated Products, Inc.

Benefits and Features

- Up to 16V Protection
- 13.4V Maximum Input Operating Voltage
- 3.15A Maximum Charging Current
- 6A Discharge Current Protection
 - No Firmware or Communication Required
 - Integrated CC Detection for USB Type-C
 - Integrated BC1.2 Detection for Legacy SDP, DCP, CDP, and DCD Timeout
 - Integrated USB Detection for Common Proprietary Charger Types
 - Automatic Input Current Limit Configuration
 - Input Voltage Regulation with Adaptive Input Current Limit (AICL)
- 5.1V, 1.5A OTG Mode and BYP Reverse Boost
- Safety
 - Charge Safety Timer
 - JEITA Compliance with NTC Thermistor Monitor
 - Thermal Shutdown
- Pin Control of all Functions
 - Resistor Configurable Fast-Charge Current/Input Current Limit/Termination Voltage
 - ENBST Pin to Enable and Disable Reverse Boost
 - STAT Pin to Indicate Charging Status
 - INOKB Pin to Indicate Input Power-OK
 - CHGENB Pin to Enable and Disable Charging
 - STBY Pin to Support Suspend Mode
 - THM Pin to Monitor Thermistor
- Integrated Power Path
- Integrated Battery True-Disconnect FET
- 2.758mm x 2.758mm, 6 x 6 WLP

Simplified Block Diagram

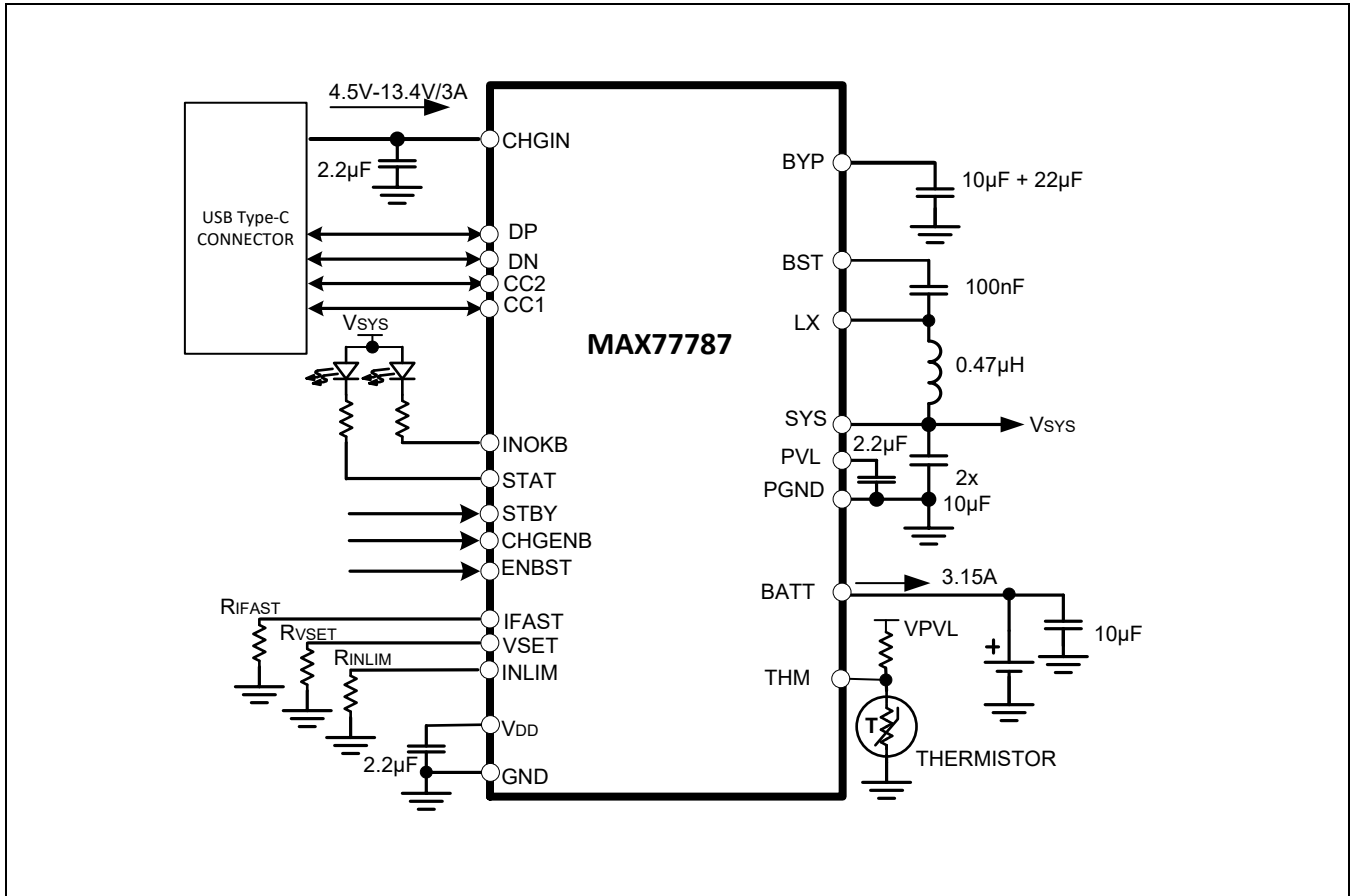

Absolute Maximum Ratings

CHGIN to GND.....	-0.3V to +16.0V	THM, IFAST, VSET to GND	-0.3V to $V_{DD} + 0.3V$
BYP, LX to PGND	-0.3V to +16.0V	V_{DD} , PVL, INLIM to GND	-0.2V to +2.2V
BATT, SYS, INOKB, STAT, ENBST, CHGENB, STBY to GND	-0.3V to +6.0V	V_{CHGIN} , BYP Continuous Current.....	3.2A _{RMS}
BST to PVL	-0.3V to +16.0V	LX, PGND Continuous Current.....	3.5A _{RMS}
BST to LX.....	-0.3V to +2.2V	SYS, BATT Continuous Current.....	4.5A _{RMS}
DN, DP to GND	-0.3V to +6.0V	Operating Temperature Range.....	-40°C to +85°C
CC1, CC2 to GND.....	-0.3V to +6.0V	Storage Temperature Range.....	-65°C to +150°C

Stresses beyond those listed under "Absolute Maximum Ratings" may cause permanent damage to the device. These are stress ratings only, and functional operation of the device at these or any other conditions beyond those indicated in the operational sections of the specifications is not implied. Exposure to absolute maximum rating conditions for extended periods may affect device reliability.

Package Information

Package Code	W362K2+1
Outline Number	21-100576
Land Pattern Number	Refer to Application Note 1891
Thermal Resistance, Four-Layer Board:	
Junction-to-Ambient (θ_{JA})	45.72°C/W
Junction-to-Case Thermal Resistance (θ_{JC})	NA

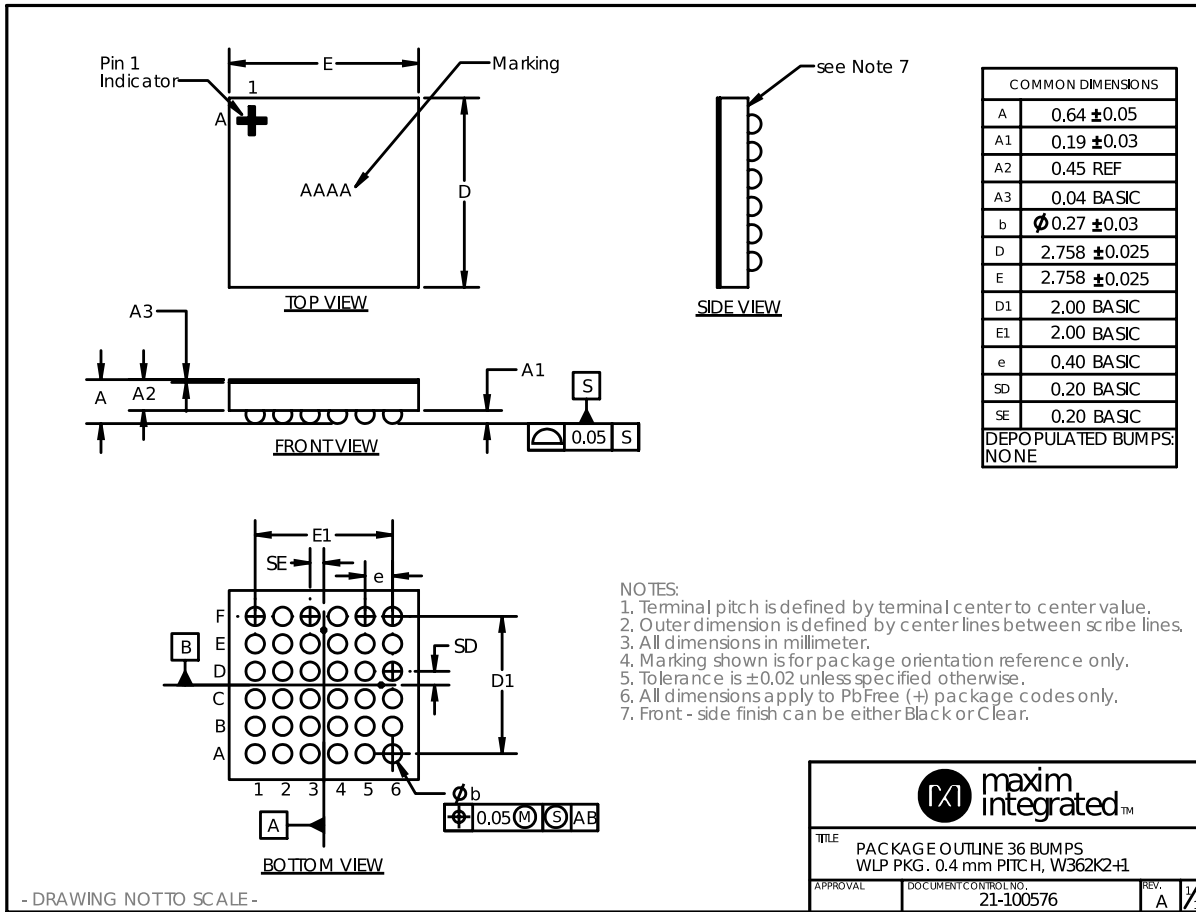

For the latest package outline information and land patterns (footprints), go to www.maximintegrated.com/packages. Note that a "+", "#", or "-" in the package code indicates RoHS status only. Package drawings may show a different suffix character, but the drawing pertains to the package regardless of RoHS status.

Package thermal resistances were obtained using the method described in JEDEC specification JESD51-7, using a four-layer board. For detailed information on package thermal considerations, refer to www.maximintegrated.com/thermal-tutorial.

Electrical Characteristics

($V_{CHGIN} = 5.0V$, Limits are 100% tested at $T_A = +25^\circ C$. Limits over the operating temperature range and relevant supply voltage range are guaranteed by design and characterization.)

PARAMETER	SYMBOL	CONDITIONS	MIN	TYP	MAX	UNITS
GENERAL ELECTRICAL CHARACTERISTICS						
Battery Only Quiescent Current	I_{BATT_Q}	USBC as UFP and BATT = SYS = 3.6V		30	50	μA
SWITCHING MODE CHARGER						
CHGIN Voltage Range	V_{CHGIN}	Operating voltage (<i>Note 1</i>)	V_{CHGIN_UVLO}		V_{CHGIN_OVLO}	V
CHGIN Overvoltage Threshold	V_{CHGIN_OVLO}	V_{CHGIN} rising	13.4	13.7	14	V
CHGIN Overvoltage Threshold Hysteresis	V_{CHGINH_OVLO}	V_{CHGIN} falling		300		mV
CHGIN to GND Minimum Turn-On Threshold Accuracy	V_{CHGIN_UVLO}	V_{CHGIN} rising	4.6	4.7	4.8	V
CHGIN to SYS Minimum Turn-On Threshold	$V_{CHGIN2SYS}$	V_{CHGIN} rising	$V_{SYS} + 0.12$	$V_{SYS} + 0.20$	$V_{SYS} + 0.28$	V
CHGIN Adaptive Voltage Regulation Threshold Accuracy	V_{CHGIN_REG}		4.4	4.5	4.6	V
CHGIN Current Limit Range	$CHGIN_ILIM$	Automatically configured after charger type detection	0.5		3.0	A
		Externally configured by R_{INLIM} when charger type detected as unknown	0.5		3.0	
CHGIN Minimum Current Threshold	I_{ULO}			65		mA
CHGIN Supply Current	I_{IN}	$V_{CHGIN} = 5.0V$, charger enabled, $V_{SYS} = V_{BATT} = 4.5V$, (No switching, battery charged)		2.7	4	mA
	I_{IN_STBY}	DCDC off, STBY = H, $V_{CHGIN} = 5V$		0.2		
	I_{IN_CHGENB}	CHGENB = H, $V_{CHGIN} = 5V$		2.7		
V_{CHGIN} Input Current Limit	$I_{INLIMIT}$	Charger enabled, 500mA input current setting, $T_A = 0^\circ C$ to $+85^\circ C$	423	460	500	mA
		Charger enabled, 1500mA input current setting, $T_A = 0^\circ C$ to $+85^\circ C$	1300	1400	1500	
		Charger enabled, 3000mA input current setting, $T_A = 0^\circ C$ to $+85^\circ C$	2600	2800	3000	
CHGIN Self-Discharge Down to UVLO Time	t_{NSD}	Time required for the charger input to cause CHGIN capacitor to decay from 6.0V to 4.3V		100		ms
CHGIN Input Self-Discharge Resistance	R_{NSD}			44		k Ω
CHGIN to BYP Resistance	$R_{CHGIN2BYP}$	Bidirectional		20		m Ω
LX High Side Resistance	R_{HS}			41		m Ω
LX Low Side Resistance	R_{LS}			41		m Ω
BATT to SYS Dropout Resistance	$R_{BAT2SYS}$			13		m Ω

($V_{CHGIN} = 5.0V$, Limits are 100% tested at $T_A = +25^\circ C$. Limits over the operating temperature range and relevant supply voltage range are guaranteed by design and characterization.)

PARAMETER	SYMBOL	CONDITIONS	MIN	TYP	MAX	UNITS
CHGIN to BATT Dropout Resistance	$R_{CHGIN2BAT}$	Calculation estimates a 0.04 Ω inductor resistance (R_L) $R_{CHGIN2BAT} = R_{CHGIN2BYP} + R_{HS} + R_L + R_{BAT2SYS}$		114		m Ω
LX Leakage Current		LX = PGND or BYP, $T_A = +25^\circ C$		0.01	10	μA
		LX = PGND or BYP, $T_A = +85^\circ C$		1		
BST Leakage Current		BST = PGND or 1.8V, $T_A = +25^\circ C$		0.01	10	μA
		BST = PGND or 1.8V, $T_A = +85^\circ C$		1		
BYP Leakage Current		$V_{BYP} = 5V$, $V_{CHGIN} = 0V$, LX = 0V, charger Disabled, $T_A = +25^\circ C$		0.01	10	μA
		$V_{BYP} = 5V$, $V_{CHGIN} = 0V$, LX = 0V, charger disabled, $T_A = +85^\circ C$		1		
SYS Leakage Current		$V_{SYS} = 0V$, $V_{BATT} = 4.2V$, charger disabled, $T_A = +25^\circ C$		0.01	10	μA
		$V_{SYS} = 0V$, $V_{BATT} = 4.2V$, charger disabled, $T_A = +85^\circ C$		1		
Minimum ON Time	t_{ON-MIN}			75		ns
Minimum OFF Time	$t_{OFF-MIN}$			75		ns
Buck Current Limit	I_{LIM}		5.16	6.0	6.84	A
Reverse Boost Quiescent Current		Non-switching: output forced 200mV above its target regulation voltage		2000		μA
Reverse Boost BYP Voltage in OTG Mode	$V_{BYP.OTG}$		4.94	5.1	5.26	V
CHGIN Output Current Limit	$I_{CHGIN.OTG.LIM}$	$3.4V < V_{BATT} < 4.5V$, $T_A = 0^\circ C$ to $+85^\circ C$	1500		1725	mA
Reverse Boost Output Voltage Ripple		Discontinuous inductor current (i.e., skip mode)		± 150		mV
		Continuous inductor current		± 150		
BATT Regulation Voltage Accuracy		$T_A = +25^\circ C$, BATT regulation voltage (See Table 5)	-0.9	-0.3	+0.3	%
BATT Regulation Voltage	V_{BATREG}	Externally programmable by R_{VSET}	3.6		4.55	V
BATT Regulation Voltage Accuracy		$T_A = 0^\circ C$ to $+85^\circ C$, BATT regulation voltage (See Table 5)	-1	-0.3	+0.5	%
Fast-Charge Current Program Range		External resistor programmable	0.5		3.15	A
Fast-Charge Currents	I_{FC}	$T_A = 0^\circ C$ to $+85^\circ C$, $V_{BATT} > V_{SYSMIN}$, programmed for 3.0A	2850	3000	3150	mA
		$T_A = 0^\circ C$ to $+85^\circ C$, $V_{BATT} > V_{SYSMIN}$, programmed for 2.0A	1900	2000	2100	
		$T_A = 0^\circ C$ to $+85^\circ C$, $V_{BATT} > V_{SYSMIN}$, programmed for 0.5A	465	500	535	
Trickle Charge Threshold	$V_{TRICKLE}$	V_{BATT} rising	3.0	3.1	3.2	V
Precharge Threshold	V_{PRECHG}	V_{BATT} rising	2.4	2.5	2.6	V
Prequalification Threshold Hysteresis	V_{PQ-H}	Applies to both $V_{TRICKLE}$ and V_{PRECHG}		100		mV

($V_{CHGIN} = 5.0V$, Limits are 100% tested at $T_A = +25^\circ C$. Limits over the operating temperature range and relevant supply voltage range are guaranteed by design and characterization.)

PARAMETER	SYMBOL	CONDITIONS	MIN	TYP	MAX	UNITS
Trickle Charge Current	$I_{TRICKLE}$	$I_{TRICKLE}$ for termination voltage from 4.1V to 4.5V option; trickle charge is disabled for 3.6V option	270	300	330	mA
Precharge Charge Current	I_{PRECHG}		40	55	80	mA
Charger Restart Threshold	V_{RSTRT}		50	100	150	mV
Charger Restart Deglitch Time		10mV overdrive, 100ns rise time		130		ms
Top-Off Current Program Range	I_{TO}	See Table 6	50		150	mA
Top-Off Current Accuracy	I_{TO}	$T_A = 0^\circ C$ to $+85^\circ C$, programmed for 150mA	130	150	170	mA
		$T_A = 0^\circ C$ to $+85^\circ C$, programmed for 50mA	25	50	75	
Charge Termination Deglitch Time	t_{TERM}	2mV overdrive, 100ns rise/fall time		30		ms
Charger Soft-Start Time	t_{SS}			1.5		ms
BATT to SYS Reverse Regulation Voltage	V_{BSREG}	$I_{BATT} = 10mA$		70		mV
		Load regulation during the reverse regulation mode		1		mV/A
Minimum SYS Voltage	$V_{SYSTEMIN}$	For termination voltage from 4.1V to 4.5V		3.5		V
		For 3.6V termination voltage		3.0		
Minimum SYS Voltage Accuracy	$V_{SYSTEMIN}$		-3		+3	%
Prequalification Time	t_{PQ}	Applies to both low-battery precharge and trickle modes		30		min
Fast-Charge Constant Current Plus Fast-Charge Constant Voltage Time	t_{FC}			6		hours
Top-Off Time	t_{TO}			30		s
Timer Accuracy			-20		+20	%
Thermal Shutdown	T_{SHDN}	T_J rising (Note 2)		165		$^\circ C$
Thermal Shutdown Hysteresis		T_J falling		15		$^\circ C$
Junction Temperature Thermal Regulation Loop Setpoint Program Range	T_{REG}	Junction temperature when charge current is reduced		130		$^\circ C$
Thermal Regulation Gain	AT_{JREG}	$I_{FC} = 3.15A$		-157.5		$mA/^\circ C$
THM Threshold, COLD	THM_COLD	V_{THM}/V_{PVL} rising, 1% hysteresis (thermistor temperature falling)	72.5	74	75.5	%
THM Threshold, COOL	THM_COOL	V_{THM}/V_{PVL} rising, 1% hysteresis (thermistor temperature falling)	63.5	65	66.5	%
THM Threshold, WARM	THM_WARM	V_{THM}/V_{PVL} falling, 1% hysteresis (thermistor temperature rising)	31	32.5	34	%
THM Threshold, HOT	THM_HOT	V_{THM}/V_{PVL} falling, 1% hysteresis (thermistor temperature rising)	21.5	23	24.5	%

($V_{CHGIN} = 5.0V$, Limits are 100% tested at $T_A = +25^\circ C$. Limits over the operating temperature range and relevant supply voltage range are guaranteed by design and characterization.)

PARAMETER	SYMBOL	CONDITIONS	MIN	TYP	MAX	UNITS
Charger Disable Threshold	V_{CHGR_EN}	V_{THM}/V_{PVL} falling, 1% hysteresis (charger is disabled below this threshold)	4.5	6	7.5	%
THM Input Leakage Current		$V_{THM} = GND$ or V_{PVL} ; $T_A = +25^\circ C$		0.1	1	μA
		$V_{THM} = GND$ or V_{PVL} ; $T_A = +85^\circ C$		0.1		
Battery Overcurrent Threshold	I_{BOVCR}			6.0		A
Battery Overcurrent Debounce Time	t_{BOVRC}		6			ms
Battery Overcurrent Retry	t_{OCP_RETRY}			0.15		sec
Battery Overcurrent Protection Quiescent Current	I_{BOVRC}			$3 \cdot I_{BATT} / 18040$		μA
System Power-Up Current	I_{SYSPU}		35	50	80	mA
System Power-Up Voltage	V_{SYSPU}	V_{SYS} rising, 100mV hysteresis	1.9	2.0	2.1	V
INOKB, STAT						
Logic Input Leakage Current				0.1	1	μA
Output Low Voltage INOKB, STAT		$I_{source} = 5mA$, $T_A = +25^\circ C$			0.4	V
Output High Leakage INOKB, STAT		$V_{SYS} = 5.5V$, $T_A = +25^\circ C$	-1	0	+1	μA
		$V_{SYS} = 5.5V$, $T_A = +85^\circ C$		0.1		
ENBST						
Logic Input Low Threshold	V_{IL}				0.4	V
Logic Input High Threshold	V_{IH}		1.4			V
Logic Input Leakage Current	I_{ENBST}	$V = 5.5V$ (including current through pulldown resistor)		24	60	μA
Pulldown Resistor	R_{ENBST}			235		k Ω
STBY						
Logic Input Low Threshold	V_{IL}				0.4	V
Logic Input High Threshold	V_{IH}		1.4			V
Logic Input Leakage Current	I_{STBY}	$V = 5.5V$ (including current through pulldown resistor)		24	60	μA
Pulldown Resistor	R_{STBY}			235		k Ω
CHGENB						
Logic Input Low Threshold	V_{IL}				0.4	V
Logic Input High Threshold	V_{IH}		1.4			V
Logic Input Leakage Current	I_{CHGENB}	$V = 5.5V$ (including current through pulldown resistor)		24	60	μA
Pulldown Resistor	R_{CHGENB}			235		k Ω
CHARGER DETECTION						

($V_{CHGIN} = 5.0V$, Limits are 100% tested at $T_A = +25^\circ C$. Limits over the operating temperature range and relevant supply voltage range are guaranteed by design and characterization.)

PARAMETER	SYMBOL	CONDITIONS	MIN	TYP	MAX	UNITS
BC1.2 State Timeout	t_{TMO}		180	200	220	ms
Data Contact Detect Time-Out	t_{DCDtmO}		700	800	900	ms
Proprietary Charger Debounce	t_{PRDeb}		5	7.5	10	ms
Primary to Secondary Timer	$t_{PDSWait}$		27	35	39	ms
Charger Detection Debounce	t_{CDDeb}		45	50	55	ms
V_{BUS64} Threshold	V_{BUS64}	DP and DN pins. Threshold in percent of V_{BUS} voltage; $3V < V_{BUS} < 5.5V$	57	64	71	%
V_{BUS64} Hysteresis	V_{BUS64_H}			0.015		V
V_{BUS47} Threshold	V_{BUS47}	DP and DN pins. Threshold in percent of V_{BUS} voltage; $3V < V_{BUS} < 5.5V$	43.3	47	51.7	%
V_{BUS47} Hysteresis				0.015		V
V_{BUS31} Threshold	V_{BUS31}	DP and DN pins. Threshold in percent of V_{BUS} voltage; $3V < V_{BUS} < 5.5V$	26	31	36	%
V_{BUS31} Hysteresis				0.015		V
I_{WEAK} Current	I_{WEAK}		0.01	0.1	0.5	μA
R_{DM_DWN} Resistor	R_{DM_DWN}		14.25	20	24.8	k Ω
I_{DP_SRC} Current	I_{DP_SRC}/I_{DCD}	Accurate over 0V to 2.5V	7	10	13	μA
I_{DM_SINK} Current	I_{DM_SINK}/I_{DAT_SINK}	Accurate over 0.15V to 3.6V	45	80	125	μA
V_{LGC} Threshold	V_{LGC}		1.62	1.7	1.9	V
V_{LGC} Hysteresis	V_{LGC_H}			0.015		V
V_{DAT_REF} Threshold	V_{DAT_REF}		0.25	0.32	0.4	V
V_{DAT_REF} Hysteresis	$V_{DAT_REF_H}$			0.015		V
V_{DN_SRC} Voltage	V_{DN_SRC}/V_{SR_C06}	Accurate over $I_{LOAD} = 0$ to $200\mu A$	0.5	0.6	0.7	V
V_{DP_SRC} Voltage	V_{DP_SRC}/V_{SR_C06}	Accurate over $I_{LOAD} = 0$ to $200\mu A$	0.5	0.6	0.7	V
COMP2 Load Resistor	R_{USB}	Load resistor on DP/DN	3	6.1	12	M Ω
CC DETECTION						
CC Pin Voltage in DFP 1.5A Mode	V_{CC_PIN}	Measured at CC pins with 126k Ω load. IDFP1.5_CC enable and $V_{AVL} \geq 2.5V$	1.85			V
CC Pin Clamp Voltage	V_{CC_CIAMP}	$60\mu A \leq I_{CC_} \leq 600\mu A$		1.1	1.32	V
CC Pin Clamp Voltage (5.5V)		$I_{CC_} < 2mA$		5.25	5.5	V
CC UFP Pulldown Resistance	R_{PD_UFP}		-10%	5.1k	+10%	Ω
CC DFP 1.5A Current Source	$I_{DFP1.5_CC}$		-8%	180	+8%	μA
CC RA RD Threshold	$V_{RA_RD0.5}$		0.15	0.2	0.25	V
CC UFP 0.5A RD Threshold	$V_{UFP_RD0.5}$		0.61	0.66	0.7	V
CC UFP 0.5A RD Hysteresis	$V_{UFP_RD0.5_H}$			0.015		V

($V_{CHGIN} = 5.0V$, Limits are 100% tested at $T_A = +25^{\circ}C$. Limits over the operating temperature range and relevant supply voltage range are guaranteed by design and characterization.)

PARAMETER	SYMBOL	CONDITIONS	MIN	TYP	MAX	UNITS
CC UFP 1.5A RD Threshold	$V_{UFP_RD1.5}$		1.16	1.23	1.31	V
CC UFP 1.5A RD Hysteresis	$V_{UFP_RD1.5_H}$			0.15		V
CC Pin Power-Up Time	$t_{ClampSwap}$	Max time allowed from removal of voltage clamp till 5.1k resistor attached			15	ms
CC Detection Debounce	t_{CCDeb}		100	119	200	ms
USB Type-C Debounce	t_{PDDeb}		10	15	20	ms
USB Type-C Quick Debounce	t_{QDeb}		0.9	1	1.1	ms

Note 1: The CHGIN input must be less than V_{CHGIN_OVLO} and greater than both V_{CHGIN_UVLO} and $V_{CHGIN2SYS}$ for the charger to turn on.

Note 2: T_{SHDN} only sets charger from charging to buck mode, T_{SHDN} is invalid in reverse-boost mode

Typical Operating Characteristics

($V_{CHGIN} = 5V$, $V_{BATT} = 3.8V$, $T_A = +25^\circ C$, unless otherwise noted.)

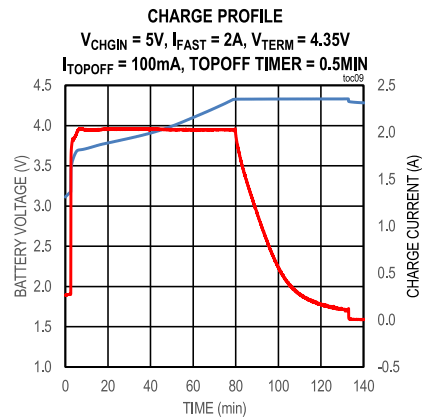
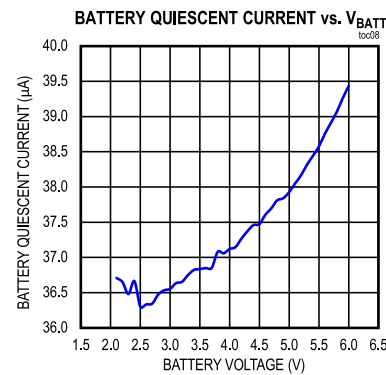
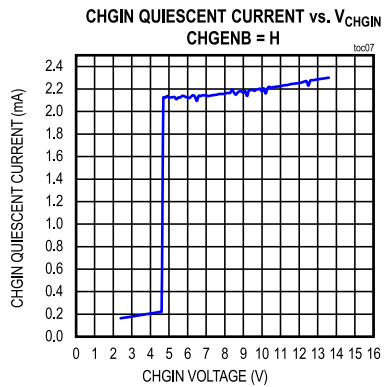
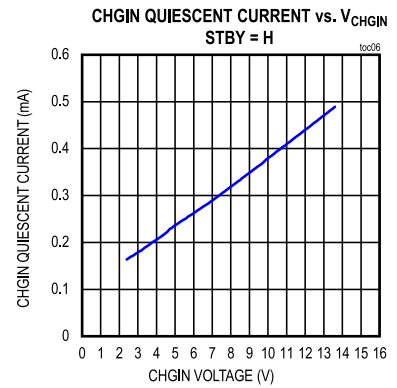
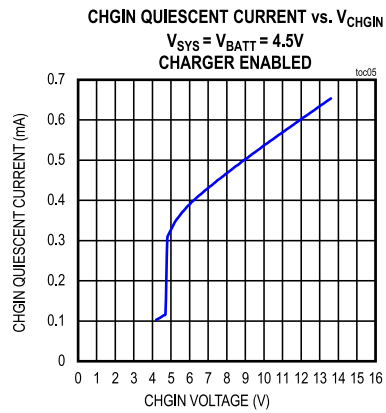
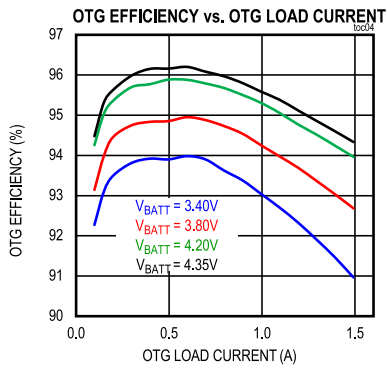
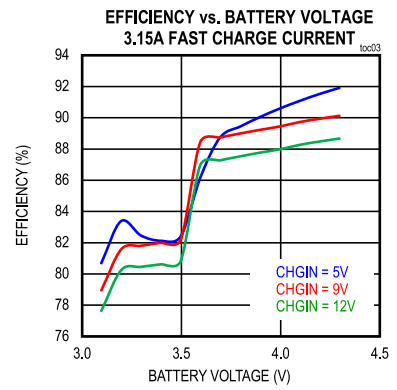
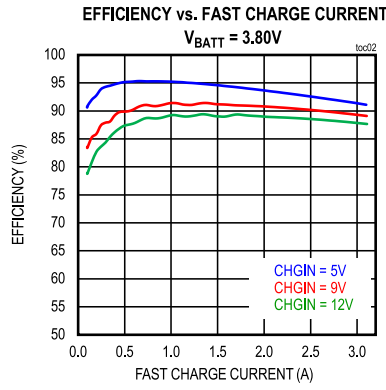
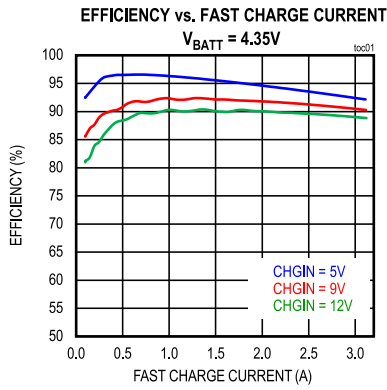

($V_{CHGIN} = 5V$, $V_{BATT} = 3.8V$, $T_A = +25^\circ C$, unless otherwise noted.)

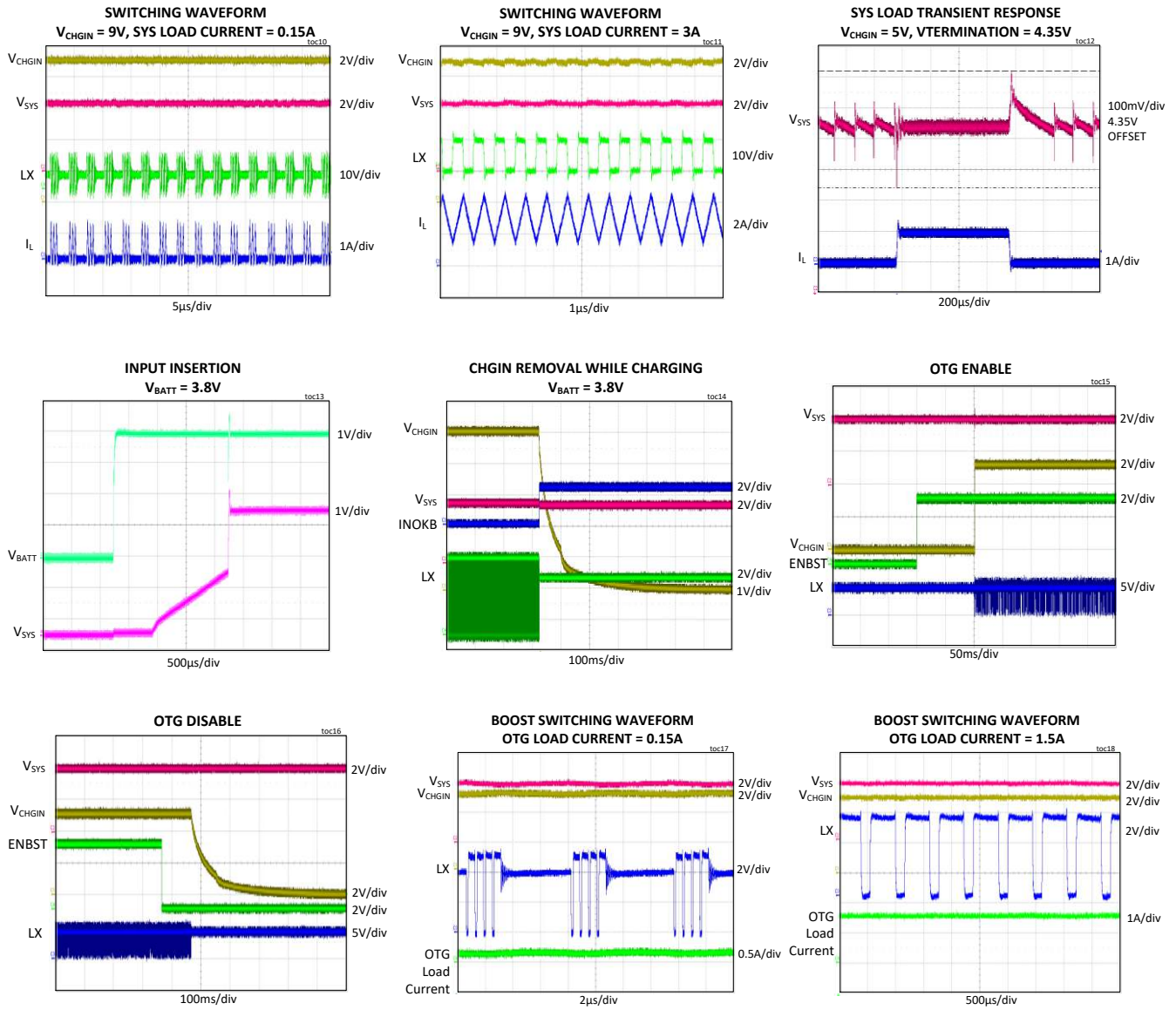

($V_{CHGIN} = 5V$, $V_{BATT} = 3.8V$, $T_A = +25^\circ C$, unless otherwise noted.)

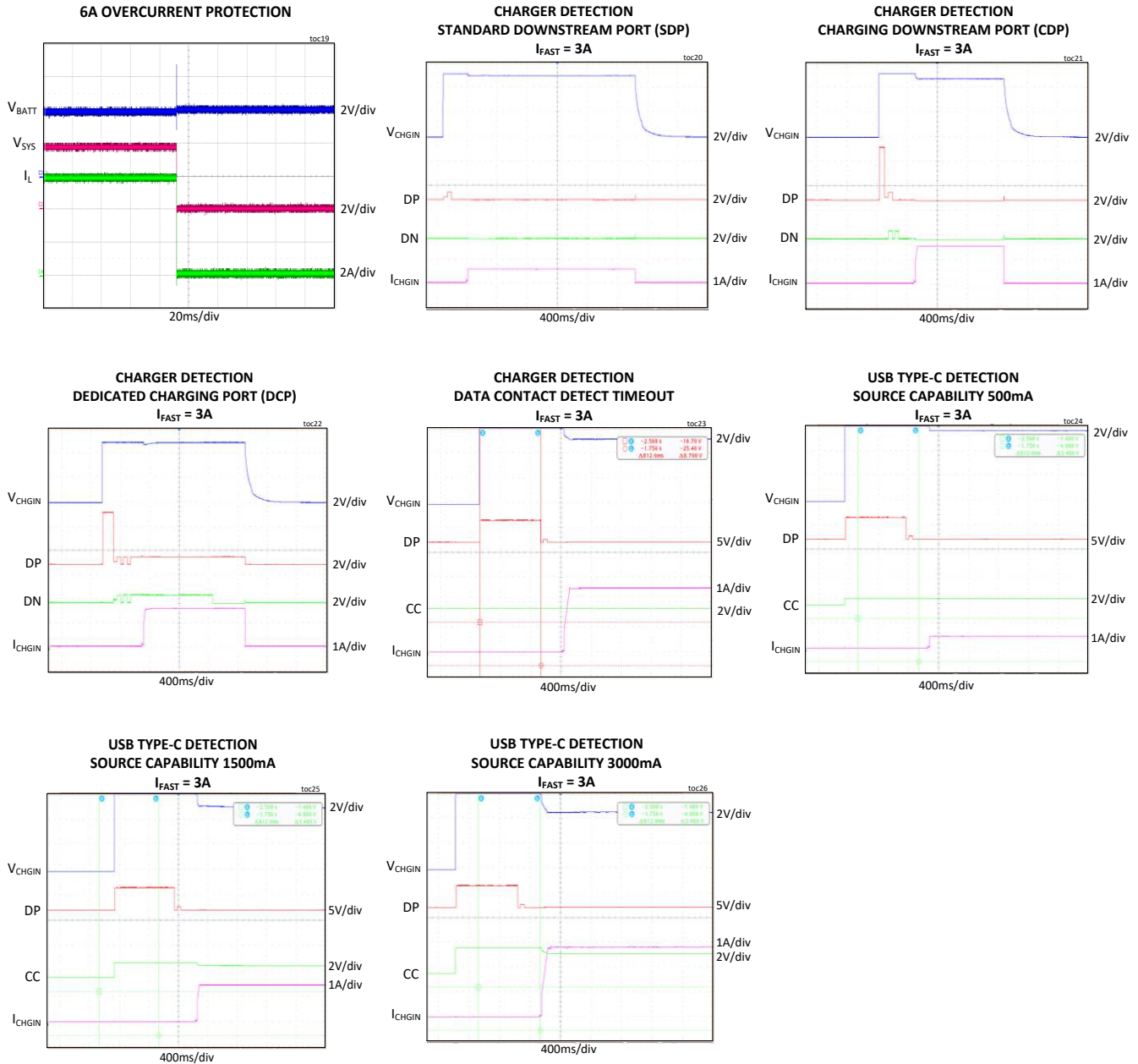

Pin Configuration

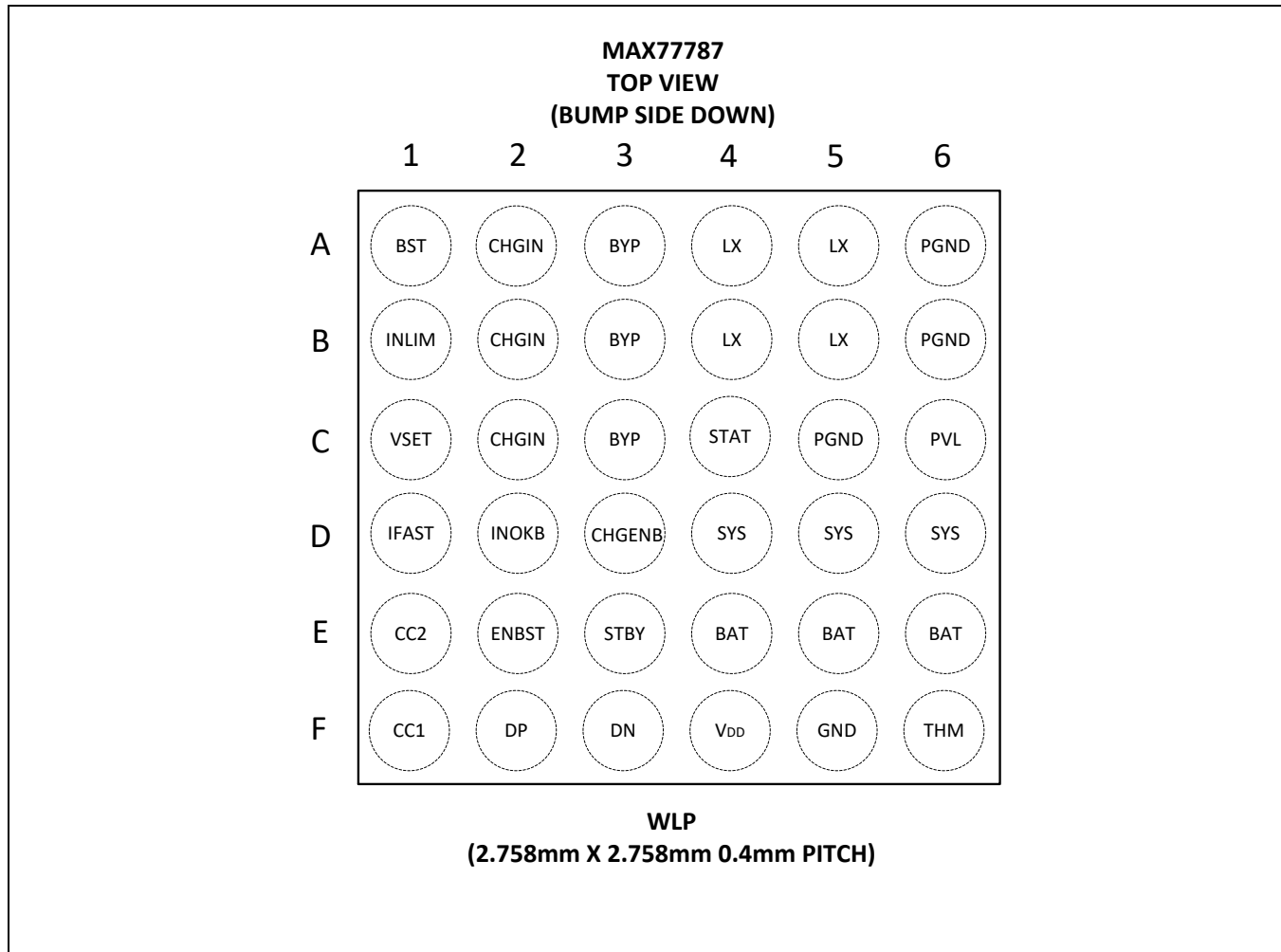

Pin Descriptions

PIN	NAME	FUNCTION
A1	BST	Provides Drive to High-Side Internal nMOS. Connect a 100nF/6.3V bootstrap capacitor between this pin and the LX node.
D2	INOKB	Charger Input Valid, Active-Low Logic Output Flag. The open-drain output indicates when a valid voltage is present at CHGIN.
C4	STAT	Open-Drain Charge Status Indication Output. STAT is toggling low and high impedance during charge. STAT becomes low when a top-off threshold is detected and in a done state. STAT becomes high impedance when charge faults happen.
E1	CC2	USB Type-C CC2 Connection
F1	CC1	USB Type-C CC1 Connection
F2	DP	Positive Line of the USB Data Line Pair. Connect to D+ on USB Type-C or micro USB connector.
F3	DN	Negative Line of the USB Data Line Pair. Connect to D- on USB Type-C or micro USB connector.
E2	ENBST	Active-High Logic Input. Enable/disable the reverse-boost converter.
F5	GND	Analog Ground. Short to ground plane.

F4	V _{DD}	Output of On-Chip LDO Used to Power On-Chip, Low-Noise Circuits. Bypass with a 2.2 μ F/10V ceramic capacitor to GND. Powering external loads from V _{DD} is not recommended other than pullup resistors.
F6	THM	Thermistor Connection. Connect an external negative temperature coefficient (NTC) thermistor from THM to GND. Connect a resistor equal to the thermistor +25°C resistance from THM to PVL. See the JEITA Compliance for details.
D1	IFAST	Fast-Charge Current Setting Pin. Connect a resistor (R _{IFAST}) from IFAST to GND to program the fast-charge current. Use 24.9k Ω for 3.15A fast-charge current.
E4,E5,E6	BATT	Battery Power Connection. Connect to the positive terminal of a single-cell (or parallel cell) Li-ion battery. Bypass BATT to PGND ground plane with a 10 μ F ceramic capacitor.
D4,D5,D6	SYS	System Power Node. Bypass SYS to PGND with a 2x10 μ F/10V ceramic capacitor.
C6	PVL	Output of On-Chip LDO, Noisy Rail due to Bootstrap Operation. Bypass with a 2.2 μ F/10V ceramic capacitor to PGND. Powering external loads from PVL is not recommended.
A6,B6,C5	PGND	Power Ground. Connect the return of the buck output capacitor close to these pins.
A4,A5,B4, B5	LX	Switching Node. Connect an inductor between LX and SYS. When the buck converter is enabled, LX switches between BYP and PGND to control the input current, battery current, battery voltage, and die temperature.
A3,B3,C3	BYP	System Power Connection. Output of OVP adapter input block and input to switching charger. Bypass with a 22 μ F/16V ceramic capacitor from BYP to PGND.
A2,B2,C2	CHGIN	Charger Input. Up to 13.4V operating, 16VDC withstand input pin connected to an adapter or USB power source. Connect a 2.2 μ F/16V ceramic capacitor from CHGIN to GND.
C1	VSET	Charge Termination Voltage Setting Input. Connecting a resistor (R _{VSET}) from VSET to GND programs the charge termination voltage.
D3	CHGENB	Active-Low Input. Battery charging is enabled when CHGENB connects to low.
E3	STBY	Active-High Input. Connect high to disable the DCDC between CHGIN input and SYS output. CHGIN supply current reduces to I _{CHGIN_STBY} . The battery supplies the system power. Connect low to control the DCDC with the power path-state machine
B1	INLIM	Charger Input Current Limit Setting Input. Connecting a resistor (R _{INLIM}) from INLIM to GND programs the charger input current limit. The input current limit setting through a resistor is valid only when the adaptor is detected as unknown. Else, the input current limit is programmed by D+/D- detection and CC detection result.

Functional Diagram

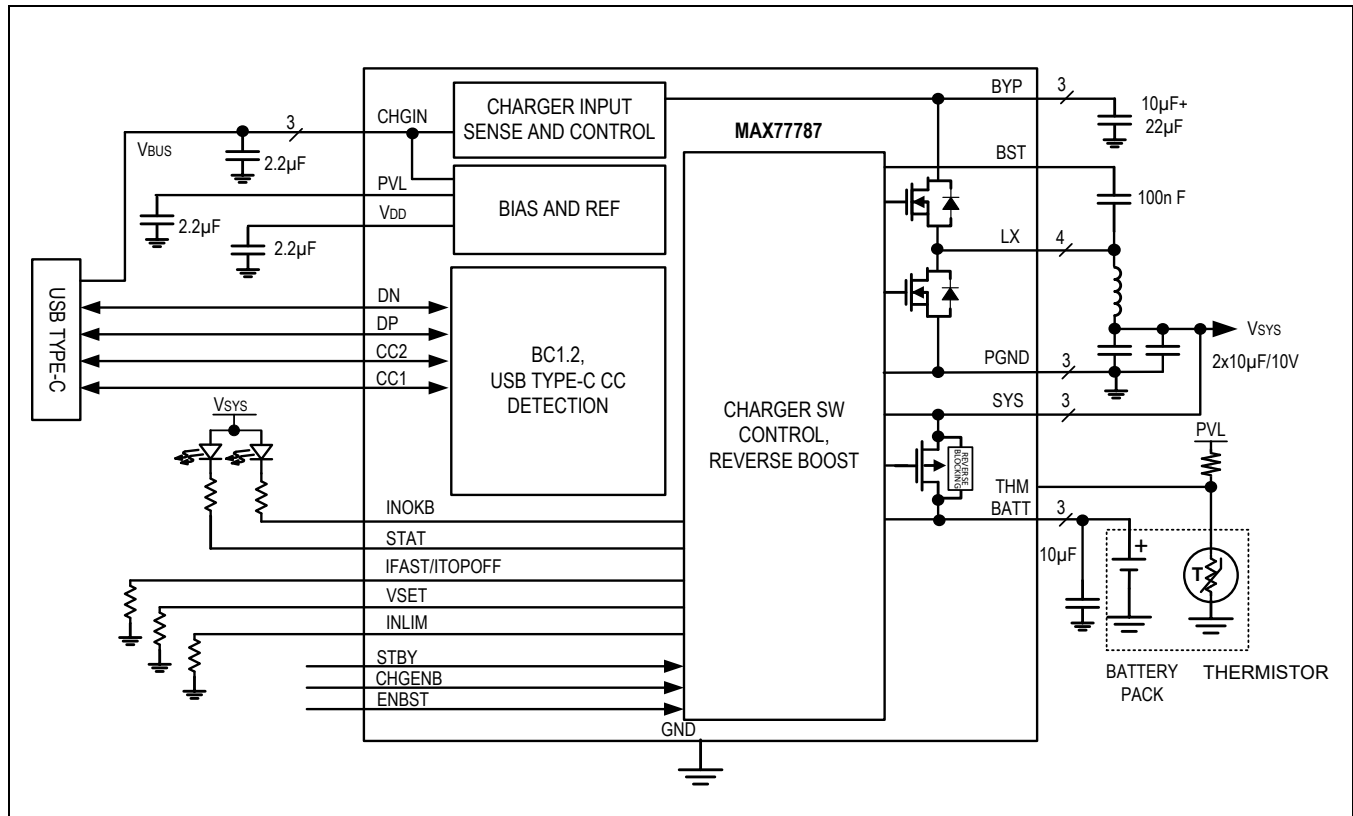

Detailed Description

The MAX77787 is a highly integrated USB Type-C charger with autonomous configuration. The IC can operate input range from 4.5V to 13.4V to support 5V, 9V, and 12V AC adapter and USB input. The fast-charge current is up to 3.15A and the max input current limit is 3.0A.

The IC can run BC1.2 and USB Type-C CC detection upon input insertion and configure input source to max power option and charger input current limit to max power.

Fast-charge current and top-off current threshold can be programmed with an external resistor. Input voltage regulation feature (AICL) even allows users to use weak AC adapters without preventing charge.

Power path design provides system power even when the battery is fully discharged and it supplements current from the battery and charge input automatically when the system demands higher current.

Reverse boost from the battery can be enabled by the ENBST and STBY pins to allow 5.1V/1.5A OTG to V_{BUS} or BYP.

Switching Mode Charger

Features

- Complete Li+/LiPoly/LiFePO₄ Battery Charger
 - Prequalification, Constant Current, Constant Voltage
 - 55mA Pre-charge Current
 - 300mA Trickle Charge Current for MAX77787J Version. For the MAX77787H version, the trickle charge current is disabled.
 - Resistor Adjustable Constant Current Charge
 - 500mA to 3.15A (See [Table 6](#))
 - Resistor Adjustable Battery Regulation Voltage
 - 3.6V to 4.55V (See [Table 5](#))

- $-0.9/+0.3\%$ Accuracy at $+25^{\circ}\text{C}$
- $-1/+0.5\%$ Accuracy from 0°C to $+85^{\circ}\text{C}$
- Synchronous Switch-Mode Based Design
- Smart Power Selector
 - Optimally Distributes Power Between the Charge Adapter, System, and Main Battery
 - When Powered by a Charge Adapter, the Main Battery can Provide Supplemental Current to the System
 - The Charge Adapter can Support the System without the Main Battery
- No External MOSFETs Required
- Single Input Operation
 - Reverse Leakage Protection Prevents the Battery Leaking Current to the Inputs
 - $V_{\text{CHGIN_OVLO}} = 13.4\text{V}$
 - Supports AC-to-DC Wall Adapters
 - Automatic Input Current Limit Selection after Charger Type Detection
 - 500mA, 1A, 2A, 2.5A, 3A
 - External Programmable Input Current Limit when Unknown Charger Type is detected
 - 500mA to 3A (See [Table 4](#))
- Charge Safety Timer
 - 6 Hour
- Die Temperature Monitor with Thermal Foldback Loop
 - Die Temperature Thresholds ($^{\circ}\text{C}$): 130°C
- Input Voltage Regulation allows Operation from High-Impedance Sources (AICL)
- BATT to SYS Switch is $13\text{m}\Omega$ Typical
 - Capable of 4.5A Steady-State Operation from BATT to SYS
- Short Circuit Protection
 - BATT to SYS Overcurrent Threshold: 6A
 - SYS Short-to-Ground
 - Buck Operates with Input Current Limit to 200mA when $V_{\text{SYS}} < V_{\text{SYSPU}}$

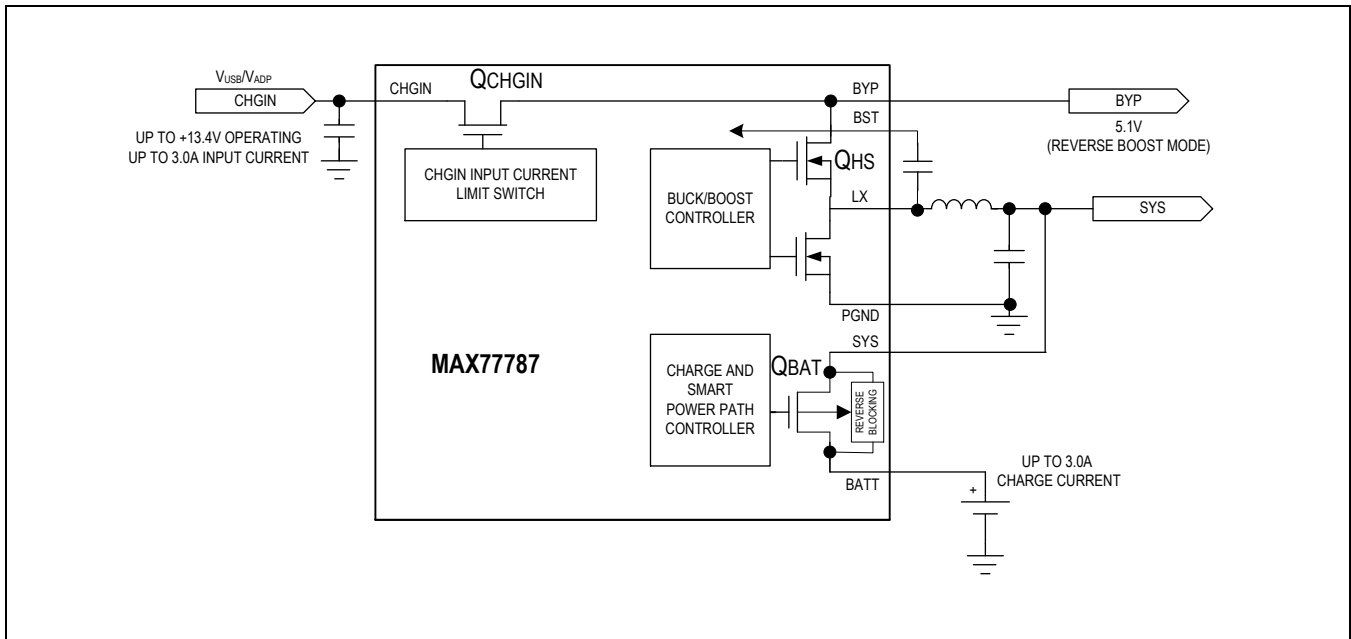

Figure 1. Simplified Functional Diagram

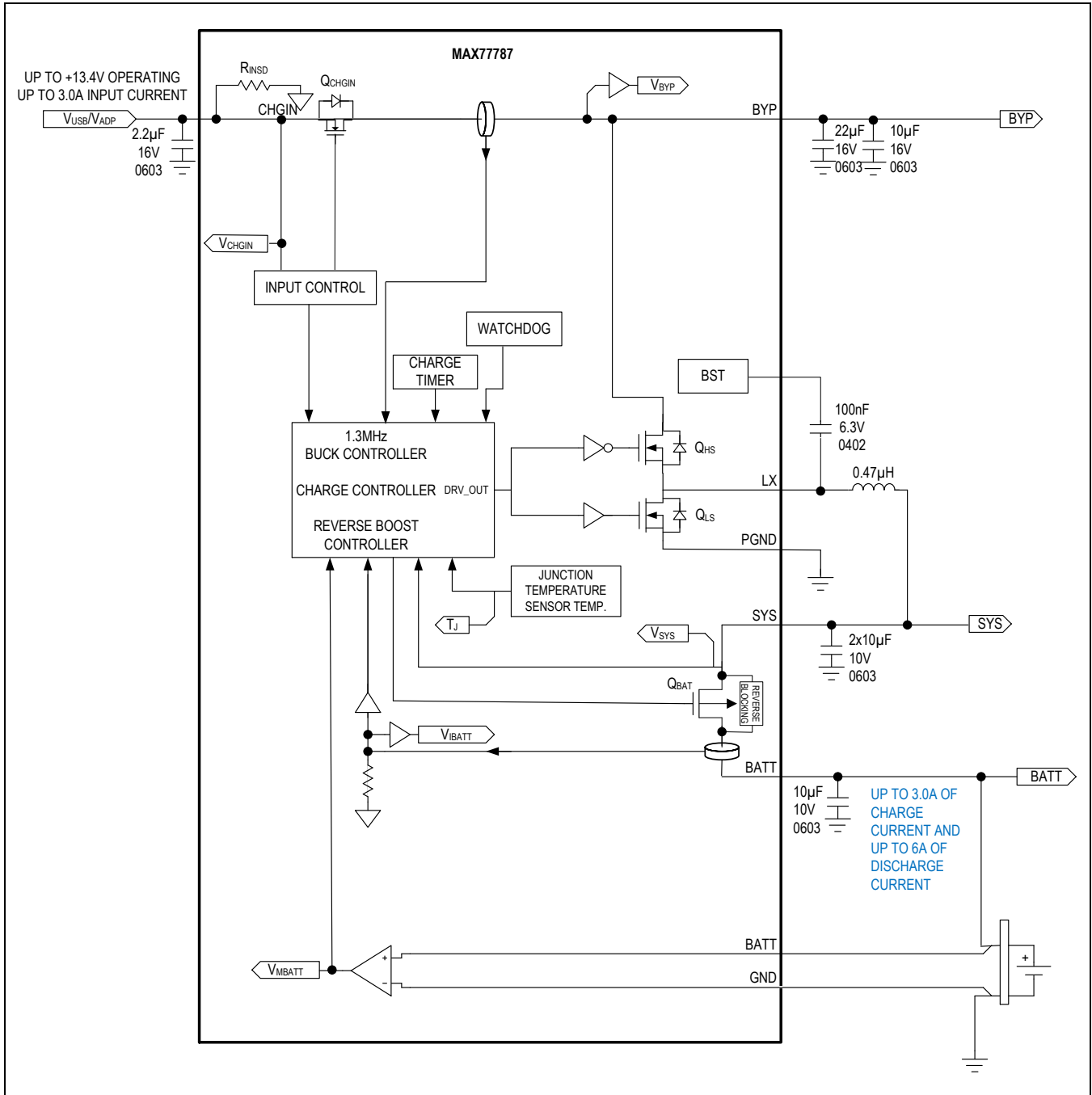

Figure 2. Main Battery Charger Detailed Functional Diagram

Detailed Description

The IC is a switch-mode charger for a one-cell lithium-ion (Li+), lithium polymer (Li-polymer) battery, or LiFePO₄ battery. As shown in [Figure 2](#), the current limit for CHGIN input is automatically configured allowing the flexibility for connection to either an AC-to-DC wall charger or a USB port.

The synchronous switch-mode DC-DC converter utilizes a high 1.3MHz switching frequency which is ideal for portable devices because it allows the use of small components while eliminating excessive heat generation. The DC-DC has both a buck and a boost mode of operation. When charging the main battery the converter operates as a buck. The DC-DC buck operates from a 4.5V to 13.4V source and delivers up to 3.15A to the battery. The battery charge current is programmable from 500mA to 3.15A with an external resistor.

As a boost converter, the DC-DC uses energy from the main battery to boost the voltage at BYP. The boosted BYP voltage is useful to supply the USB OTG voltage which is fixed to 5.1V.

Maxim's Smart Power Selector architecture makes the best use of the limited adapter power and the battery's power at all times to supply up to Buck Current Limit from the buck to the system. (Additionally, supplement mode provides additional current from the battery to the system up to B2SOVRC.) Adapter power that is not used for the system goes to charging the battery. All power switches for charging and switching the system load between the battery and adapter power are included on-chip—no external MOSFETs are required.

Maxim's proprietary process technology allows for low-R_{DS(on)} devices in a small solution size. The total dropout resistance from adapter power input to the battery is 114mΩ (typ) assuming that the inductor has 0.04Ω of ESR. This 114mΩ typical dropout resistance allows for charging a battery up to 3.0A from a 5V supply. The resistance from the BATT-to-SYS node is 13mΩ, allowing for low power dissipation and long battery life.

A multitude of safety features ensures reliable charging. Features include a charge timer, junction thermal regulation, over/undervoltage protection, and short circuit protection.

The BATT-to-SYS switch has overcurrent protection (see the [Main Battery Overcurrent Protection](#) section for more information).

Smart Power Selector (SPS)

The SPS architecture is a network of internal switches and control loops that distributes energy between an external power source CHGIN, BYP, SYS, and BATT.

[Figure 1](#) shows a simplified arrangement for the Smart Power Selector's power steering switches. [Figure 2](#) shows a more detailed arrangement of the Smart Power Selector switches and gives them the following names: Q_{CHGIN}, Q_{HS}, Q_{LS}, and Q_{BAT}.

Switch and Control Loop Descriptions

- CHGIN Input Switch: Q_{CHGIN} provides the input overvoltage protection of +16V. The input switch is either completely on or completely off. As shown in [Figure 2](#), there are SPS control loops that monitor the current through the input switches as well as the input voltage.
- DC-DC Switches: Q_{HS} and Q_{LS} are the DC-DC switches that can operate as a buck (step-down) or a boost (step-up). When operating as a buck, energy is moved from BYP to SYS. When operating as a boost, energy is moved from SYS to BYP. SPS control loops monitor the DC-DC switch current, the SYS voltage, and the BYP voltage.
- Battery-to-System Switch: Q_{BAT} controls the battery charging and discharging. Additionally, Q_{BAT} allows the battery to be isolated from the system (SYS). An SPS control loop monitors the Q_{BAT} current.

SYS Regulation Voltage

- When the DC-DC is enabled as a buck and the charger is enabled but in a non-charging state such as done, thermal shutdown, or timer fault, V_{SYS} is regulated to V_{BATTREG}, and Q_{BAT} is off.
- When the DC-DC is enabled as a buck and charging in trickle-charge, fast-charge, or top-off modes, V_{SYS} is regulated to V_{SYSMIN} when the V_{PRECHG} < V_{BATT} < V_{SYSMIN}. And, when the DC-DC is enabled as a buck and charging in precharge mode (V_{BATT} < V_{PRECHG}), V_{SYS} is regulated to V_{BATTREG}. In these modes, the Q_{BAT} switch acts as a linear regulator and dissipates power [P = (V_{SYS} - V_{BATT}) × I_{BATT}]. When V_{BATT} > V_{SYSMIN}, then V_{SYS} = V_{BATT} + I_{BATT} × R_{BAT2SYS}. In this mode, the Q_{BAT} switch is closed.

In all of the above modes, if the combined SYS loading exceeds the input current limit, then V_{SYS} drops to $V_{BATT} - V_{BSREG}$, and the battery provides supplemental current.

Input Validation

The charger input is compared with several voltage thresholds to determine if it is valid. A charger input must meet the following three characteristics to be valid:

- CHGIN must be above V_{CHGIN_UVLO} to be valid. Once CHGIN is above the UVLO threshold, the information (together with LIN2SYS, described below) is latched and can only be reset when the charger is in the adaptive input current loop (AICL) and the input current is lower than the IULO threshold of 60mA. Note that V_{CHGIN_REG} is lower than their UVLO falling threshold, respectively.
- CHGIN must be below its overvoltage lockout threshold (V_{CHGIN_OVLO})
- CHGIN must be above the system voltage by $V_{CHGIN2SYS}$

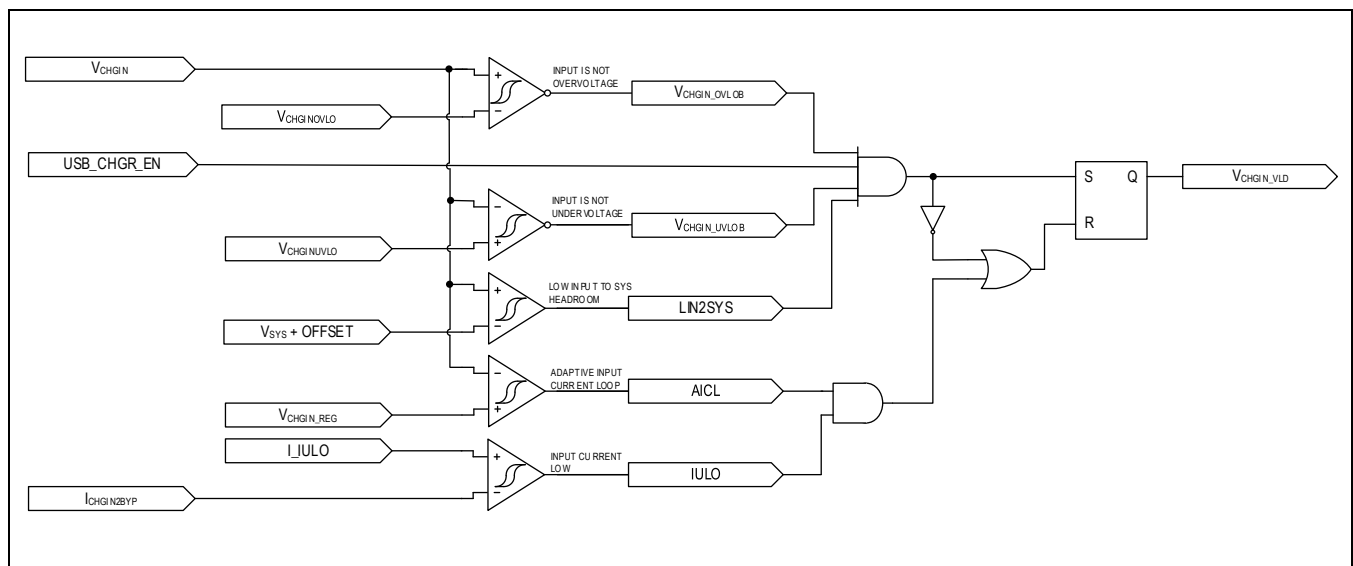

Figure 3. CHGIN Valid Signal Generation Logic

The INOKB pin is pulled down when $CHGINOK = 1$ and the switcher starts.

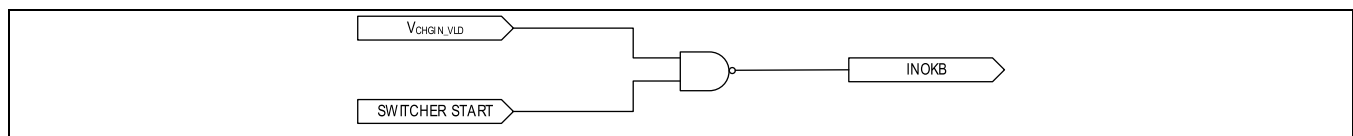

Figure 4. INOKB Signal Generation Logic

Input Current Limit

The IC has two ways to control the input current limit. After the charger-type detection is done, the IC automatically configures the input current limit to the highest settings that the source can provide. If the input source is not a standard power source described by BC1.2, USB Type-C, or proprietary charger type that the IC can detect, the IC sets the input current limit according to R_{INLIM} . In the case of floating R_{INLIM} , the IC input current limit is set to 500mA when an unknown proprietary charger is detected.

Input Voltage Regulation Loop

An input voltage regulation loop allows the charger to be well behaved when it is attached to a poor-quality charge source. The loop improves performance with relatively high resistance charge sources that exist when long cables are used or devices are charged with non-compliant USB hub configurations.

The input voltage regulation loop automatically reduces the input current limit to keep the input voltage at V_{CHGIN_REG} . If the input current limit is reduced to I_{ULO} (65mA typ) and the input voltage is below V_{CHGIN_REG} , then the charger input is turned off.

Input Self-Discharge

To ensure that a rapid removal and reinsertion of a charge source always results in a charger input interrupt, the charger input presents loading to the input capacitor to ensure that when the charge source is removed the input voltage decays below the UVLO threshold in a reasonable time (t_{INSD}). The input self-discharge is implemented with a 44kΩ resistor (R_{INSD}) from CHGIN input to ground.

Charger States

Li+/Li-Poly Battery

The MAX77787J utilizes several charging states to safely and quickly charge Li+/Li-Poly batteries as shown in [Figure 5](#) and [Figure 6](#). [Figure 5](#) shows an exaggerated view of the Li+/Li-Poly battery progressing through the following charge states when there is no system load and the die and battery is close to room temperature: precharge → trickle → fast-charge → top-off → done.

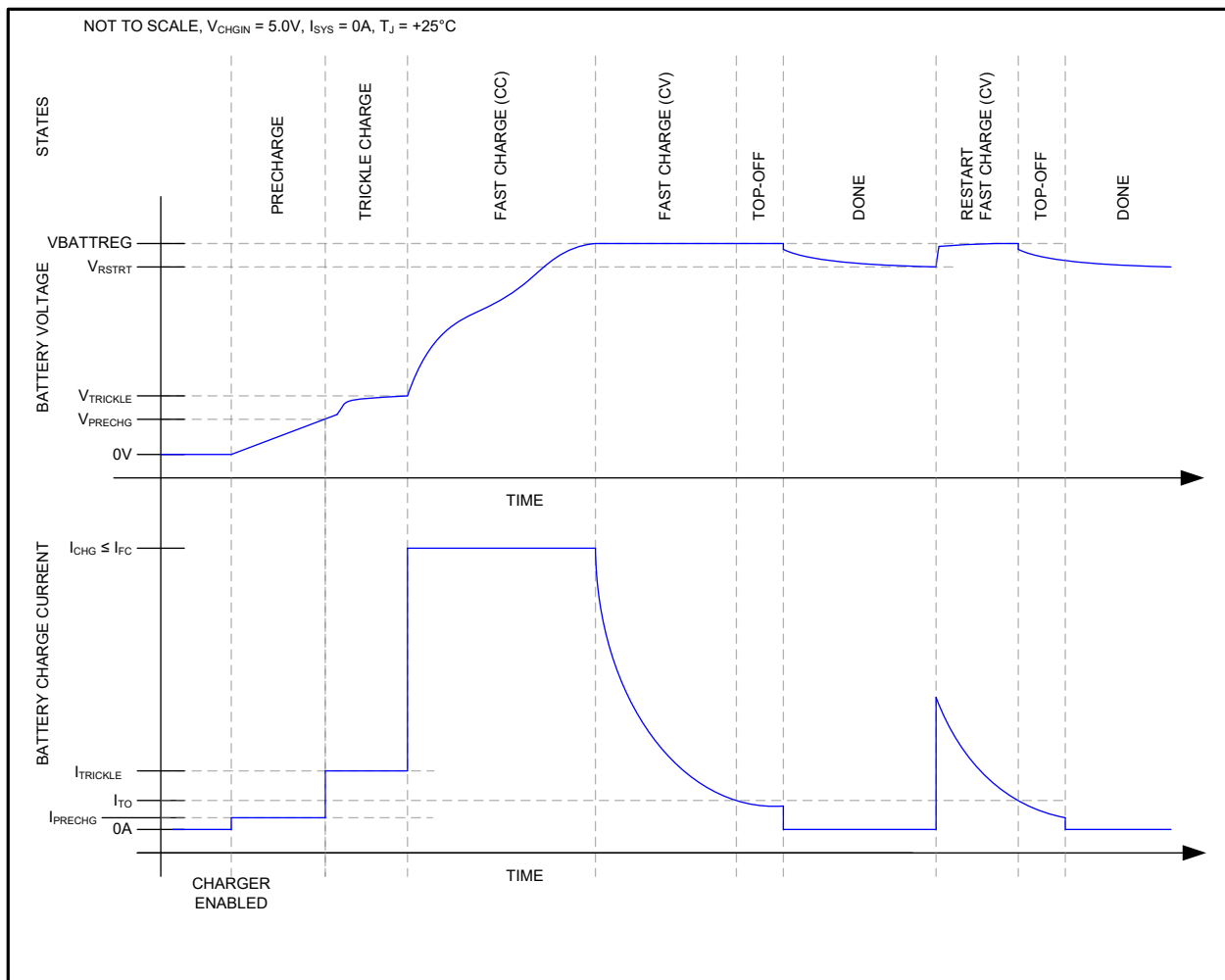

Figure 5. Li+/Li-Poly Charge Profile

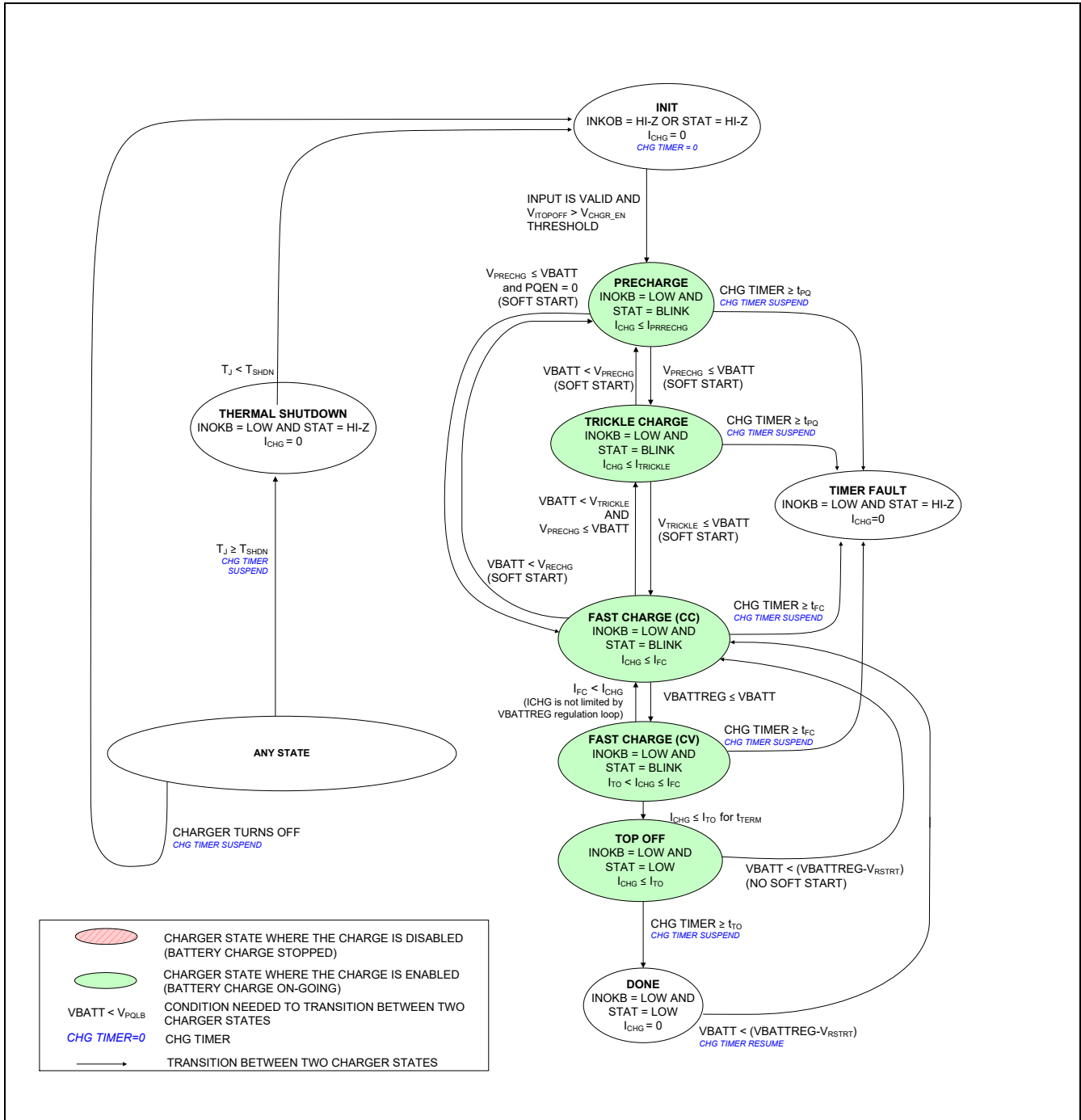

Figure 6. Li+/Li-Poly Charger State Diagram

LiFePO₄ Battery

As for the LiFePO₄ battery, the MAX77787H skips the trickle charge state and directly enters the fast-charge state after the precharge state. [Figure 7](#) and [Figure 8](#) presents the LiFePO₄ battery charge profile and state machine: precharge → fast-charge → top-off → done.

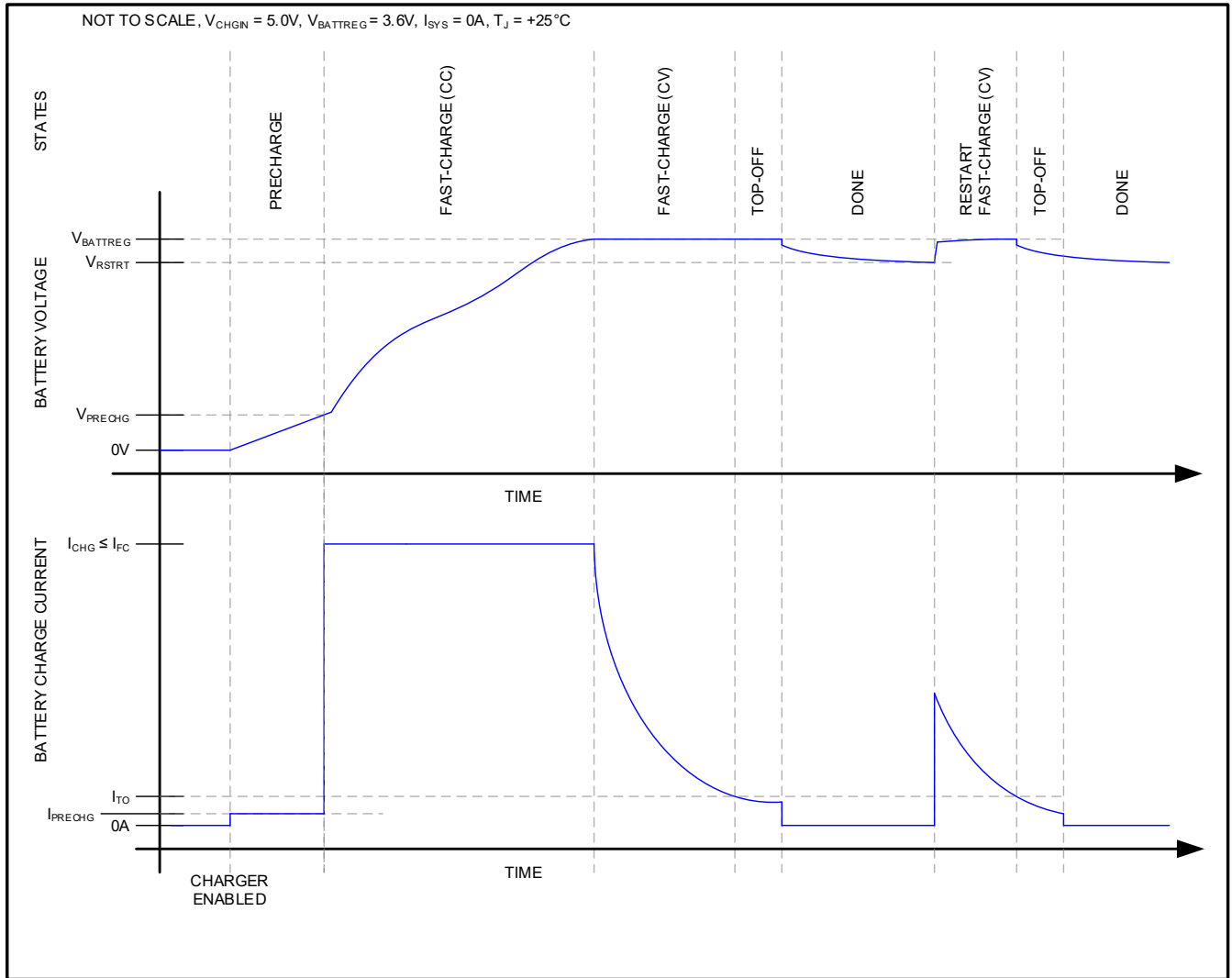

Figure 7. LiFePO₄ Battery Charge Profile

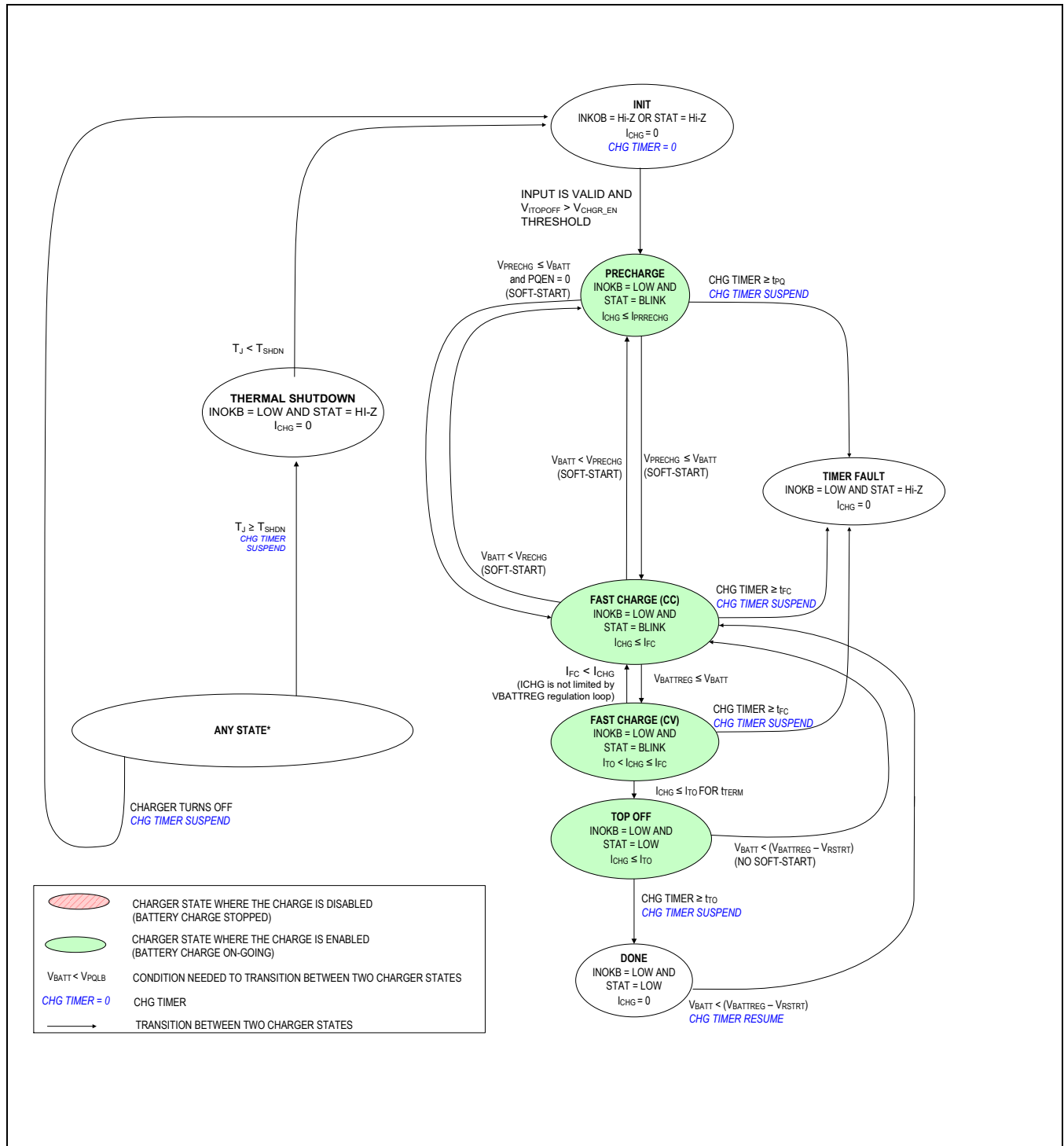

Figure 8. LiFePO₄ State Machine

INIT State

From any state shown in [Figure 6](#) except thermal shutdown, the “INIT” state is entered whenever the charger inputs CHGIN is invalid or the charger timer is suspended.

While in the “INIT” state, the charger current is 0mA, the charge timer is forced to 0, and the power to the system is provided by the battery.

To exit the “INIT” state the charger input must be valid.

Pre-Charge State

As shown in [Figure 6](#), the pre-charge state occurs when the main battery voltage is less than V_{PRECHG} . In the pre-charge state, the charge current into the battery is I_{PRECHG} .

The following events cause the state machine to exit this state:

- The main battery voltage rises above V_{PRECHG} and the charger enters the next state in the charging cycle, trickle charge.
- If the battery charger remains in this state for longer than t_{PQ} , the charger state machine transitions to the timer fault state.

Note that the pre-charge state works with battery voltages down to 0V. The low 0V operation typically allows the battery charger to recover batteries that have an “open” internal pack protector. Typically, a pack internal protection circuit opens if the battery has seen an overcurrent, undervoltage, or overvoltage. When a battery with an “open” internal pack protector is used with this charger, the pre-charge mode current flows into the 0V battery—this current raises the pack’s terminal voltage to the point where the internal pack protection switch closes.

Note that a normal battery typically stays in the pre-charge state for several minutes or less. Therefore, a battery that stays in the pre-charge state for longer than t_{PQ} might be experiencing a problem.

Trickle Charge State

The trickle charge mode described below is for Li-ion and Li-poly batteries only, with charge termination voltage from 4.1V to 4.5V.

As shown in [Figure 6](#), the trickle charge state occurs when $V_{BATT} > V_{PRECHG}$ and $V_{BATT} < V_{TRICKLE}$.

When the MAX77787J is in its trickle charge state, the charge current in the battery is less than or equal to $I_{TRICKLE}$.

Charge current might be less than $I_{TRICKLE}$ for the following reasons:

- The charger input is in the input current limit
- The charger input voltage is low
- The charger is in thermal foldback
- The system load is consuming adapter current. Note that the system load always gets priority over the battery charge current.

The following events cause the state machine to exit this state:

- When the main battery voltage rises above $V_{TRICKLE}$, the charger enters the next state in the charging cycle, fast charge (CC).
- If the battery charger remains in this state for longer than t_{PQ} , the charger state machine transitions to the timer fault state.

Note that a normal battery typically stays in the trickle charge state for several minutes or less. Therefore, a battery that stays in trickle charge for longer than t_{PQ} might be experiencing a problem.

Based on the characteristic of the LiFePO4 battery, the trickle charge state of MAX77787H is disabled. After the pre-charge state, when $V_{PRECHG} < V_{BATT} < V_{BATTREG}$, MAX77787H enters the fast-charge constant current state to improve the charger efficiency.

Fast-Charge Constant Current (CC) State

As shown in [Figure 6](#), the fast-charge constant current (CC) state occurs when the main-battery voltage is greater than the trickle threshold and less than the battery regulation threshold ($V_{TRICKLE} < V_{BATT} < V_{BATTREG}$).

In the fast-charge CC state, the current into the battery is less than or equal to I_{FC} . Charge current can be less than I_{FC} for the following reasons:

- The charger input is in the input current limit
- The charger input voltage is low
- The charger is in thermal foldback
- The system load is consuming adapter current. Note that the system load always gets priority over the battery charge current.

The following events cause the state machine to exit this state:

- When the main battery voltage rises above $V_{BATTREG}$, the charger enters the next state in the charging cycle, fast charge (CV).
- If the battery charger remains in this state for longer than t_{FC} , the charger state machine transitions to the timer fault state.

The battery charger dissipates the most power in the fast-charge constant current state. This power dissipation causes the internal die temperature to rise. If the die temperature exceeds T_{REG} , I_{FC} is reduced. See the [Thermal Foldback](#) section for more information.

Fast-Charge Constant Voltage (CV) State

As shown in [Figure 6](#), the fast-charge constant voltage (CV) state occurs when the battery voltage rises to $V_{BATTREG}$ from the fast-charge CC state.

In the fast-charge CV state, the battery charger maintains $V_{BATTREG}$ across the battery and the charge current is less than or equal to I_{FC} . As shown in [Figure 5](#), charger current decreases exponentially in this state as the battery becomes fully charged.

The Smart Power Selector control circuitry might reduce the charge current lower than the battery can otherwise consume for the following reasons:

- The charger input is in the input current limit
- The charger input voltage is low
- The charger is in thermal foldback
- The system load is consuming adapter current. Note that the system load always gets priority over the battery charge current.

The following events cause the state machine to exit this state:

- When the charger current is below I_{TO} for t_{TERM} , the charger enters the next state in the charging cycle, top off.
- If the battery charger remains in this state for longer than t_{FC} , the charger state machine transitions to the timer fault state.

Top-Off State

As shown in [Figure 6](#), the top-off state can only be entered from the fast-charge CV state when the charger current decreases below I_{TO} for t_{TERM} . In the top-off state, the battery charger tries to maintain $V_{BATTREG}$ across the battery, and typically the charge current is less than or equal to I_{TO} .

The Smart Power Selector control circuitry might reduce the charge current lower than the battery can otherwise consume for the following reasons:

- The charger input is in the input current limit
- The charger input voltage is low
- The charger is in thermal foldback
- The system load is consuming adapter current. Note that the system load always gets priority over the battery charge current.

The following events cause the state machine to exit this state:

- After being in this state for the top-off time (t_{TO}), the charger enters the next state in the charging cycle, done.
- If $V_{BATT} < V_{BATTREG} - V_{RSTRT}$, the charger goes back to the fast charge (CC) state

Done State

As shown in [Figure 6](#), the battery charger enters its done state after the charger has been in the top-off state for t_{TO} .

The following event causes the state machine to exit this state:

- If $V_{BATT} < V_{BATTREG} - V_{RSTRT}$, the charger goes back to the fast charge (CC) state

In the done state, the charge current into the battery (I_{CHG}) is 0A. In the done state, the charger presents a very low quiescent current to the battery. If the system load presented to the battery is low ($\ll 100\mu A$), then a typical system can remain in the done state for many days. If left in the done state long enough, the battery voltage decays below the restart threshold (V_{RSTRT}), and the charger state machine transitions back into the fast-charge CC state. There is no soft-start (di/dt limiting) during the done to fast-charge state transition.

Timer Fault State

The battery charger provides both a charge timer to ensure safe charging. As shown in [Figure 6](#), the charge timer prevents the battery from charging indefinitely. The time that the charger is allowed to remain in each of its prequalification states is t_{PQ} . The time that the charger is allowed to remain in the fast-charge CC and CV states is t_{FC} . Finally, the time that the charger is in the top-off state is t_{TO} . Upon entering the timer fault state, STAT becomes Hi-Z.

In the timer fault state, the charger is off. The charger input can be removed and re-inserted to exit the timer fault state (see the “any state” bubble in the lower left of [Figure 6](#)).

Thermal Shutdown State

As shown in [Figure 6](#), the thermal shutdown state occurs when the battery charger is in any state and the junction temperature (T_J) exceeds the device’s thermal shutdown threshold (T_{SHDN}). When T_J is close to T_{REG} , the charger folds back the input current limit to 0A so that the charger and inputs are effectively off.

In the thermal shutdown state, the charger is off.

Reverse Boost Mode

The DC-DC converter topology of the IC allows it to operate as a buck converter or as a reverse-boost converter. The modes of the DC-DC converter are controlled by ENBST. When ENBST = high, the DC-DC converter operates in reverse boost mode allowing it to source current to BYP and CHGIN, this mode allows current to be sourced from CHGIN and is commonly referred to as OTG mode or a source role. When the OTG mode is enabled, the unipolar CHGIN transfer function measures the current going out of CHGIN. The BYP to CHGIN switch automatically tries to retry after 300ms if CHGIN loading exceeds the 1.5A current limit. If the overload at CHGIN persists, then the CHGIN switch toggles ON and OFF with approximately 60ms ON and approximately 300ms OFF.

The IC also allows it to be sourced from BYP with ENBST = high and STBY = high.

The current through the BYP to CHGIN switch is limited to 1.5A minimum.

Note that injecting the higher V_{CHGIN} than 5.1V in case of reverse boost mode enabled causes reverse boost function to be abnormal.

Main Battery Overcurrent Protection During System Power-Up

The main battery overcurrent protection during the system power-up feature limits the main battery to system current to I_{SYSPU} as long as V_{SYS} is less than V_{SYSPU} . This feature limits the surge current that typically flows from the main battery to the device's low-impedance system bypass capacitors during a system power-up. System power-up is anytime that energy from the battery is supplied to SYS when $V_{SYS} < V_{SYSPU}$. This "system power-up" condition typically occurs when a battery is hot-inserted into an otherwise unpowered device.

When "system power-up" occurs due to hot-insertion into an otherwise unpowered device, a small delay is required for this feature's control circuits to activate. A current spike over I_{SYSPU} might occur during this time.

Main Battery Overcurrent Protection Due to Fault

The IC protects itself, the battery, and the system from potential damage due to excessive battery discharge current. Excessive battery discharge current can occur for several reasons such as exposure to moisture, a software problem, an IC failure, a component failure, or a mechanical failure that causes a short circuit.

When the main battery (BATT)-to-system (SYS) discharge current (I_{BATT}) exceeds 6A for at least t_{BOVRC} , then the IC disables the BATT-to-SYS discharge path (Q_{BAT} switch) and turns off the buck. Under OCP fault condition, when SYS is low ($V_{SYS} < V_{SYSUP}$) for t_{ocp_retry} , the IC restarts on its own and attempts to pull up SYS again. If the fault condition remains, the whole cycle repeats until this fault condition is removed.

Thermal Management

The IC charger uses several thermal management techniques to prevent excessive battery and die temperatures.

Thermal Foldback

Thermal foldback maximizes the battery charge current while regulating the IC junction temperature. As shown in [Figure 9](#), when the die temperature exceeds the $REGTEMP$ (T_{JREG}), a thermal limiting circuit reduces the battery charger's target current by 5% of the fast-charge current per $1^{\circ}C$ (A_{TJREG}), which corresponds to $157.5mA/^{\circ}C$ when the fast-charge current is 3.15A. For lower programmed charge currents such as 480mA, this slope is valid for charge current reductions down to 80mA; below 100mA the slope becomes shallower but the charge current is still reduced to 0A if the junction temperature is $20^{\circ}C$ above the programmed loop set point. The target charge current reduction is achieved with an analog control loop (i.e., not a digital reduction in the input current).

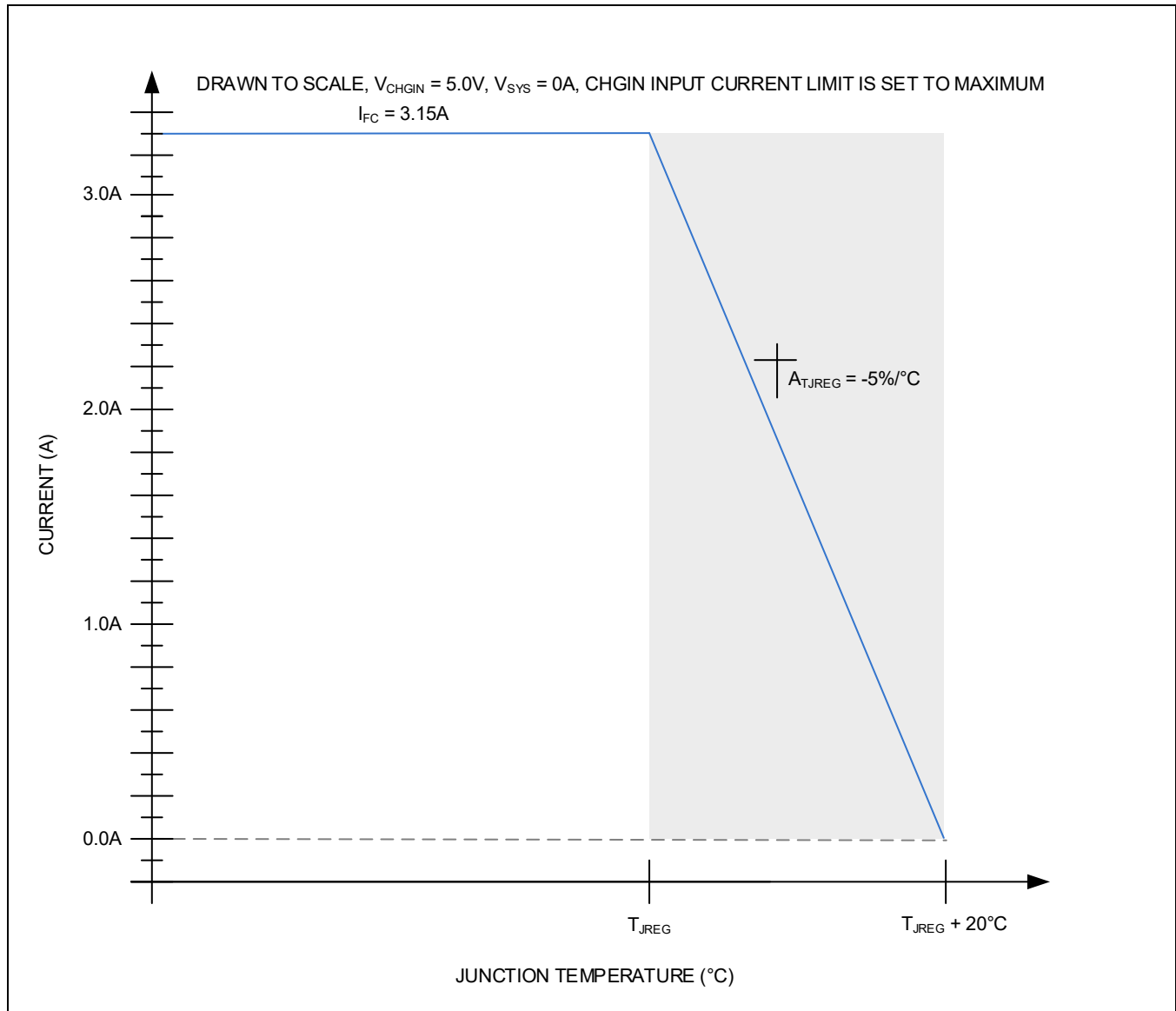

Figure 9. Charge Currents vs. Junction Temperature

Thermistor Input (THM)

The thermistor input can be utilized to achieve functions including charge suspension and JEITA-compliant charging.

JEITA Compliance

The MAX77787J version safely charges batteries in accordance with JEITA specifications. The MAX77787J version monitors the battery temperature with an NTC thermistor connected at the THM pin and automatically adjusts the fast-charge current or charge termination voltage as the battery temperature varies.

The JEITA controlled fast-charge current is reduced to 50% of the detected fast-charge current for $T_{COLD} < T < T_{COOL}$.

The charge termination voltage for $T_{WARM} < T < T_{HOT}$ is reduced to programmed termination voltage -150mV, as shown in [Figure 10](#). Charging is suspended when the battery temperature is too cold or too hot ($T < T_{COLD}$ or $T_{HOT} < T$).

The MAX77787H version disables the JEITA under warm and cool conditions and stops charging when the temperature is too hot or cold. See the [Ordering Information](#) for details.

Temperature thresholds (T_{COLD} , T_{COOL} , T_{WARM} , and T_{HOT}) depend on the thermistor selection. See [Table 1](#) for more details.

Since the thermistor monitoring circuit employs an external bias resistor from THM to PVL, the thermistor is not limited only to 10k Ω (at +25°C); any resistance thermistor can be used if the value is equivalent to the thermistors +25°C resistance. The thermistor installed on the evaluation kit is 10k Ω with a beta of 3435.

The general relation of thermistor resistance to temperature is defined by the following equation:

$$R_T = R_{25} \times e^{\left[\beta \times \left(\frac{1}{T+273} - \frac{1}{298}\right)\right]}$$

where

R_T = The resistance in Ω of the thermistor at temperature T in Celsius

R_{25} = The resistance in Ω of the thermistor at +25°C

β = The material constant of the thermistor, which typically ranges from 3000k to 5000k

T = The temperature of the thermistor in Celsius

Table 1. Temperature Threshold for Different Thermistors

THERMISTOR PART NUMBER	BETA (β)	R25 (Ω)	EXTERNAL BIAS RESISTOR FROM THM TO PVL, RTB (Ω)	JEITA TEMPERATURE THRESHOLD (TYPICAL)			
				T_{COLD} (°C)	T_{COOL} (°C)	T_{WARM} (°C)	T_{HOT} (°C)
TX04F103F3380ER	3380	10000	10000	-0.2	9.6	45.5	60.5
NCP15XH103F03	3435	10000	10000	0.2	9.8	45.2	59.9
TH05-3N333FR	3725	33000	33000	2	10.9	43.5	56.9
TH05-4B473FR	4057	47000	47000	3.7	12	41.9	54
NTCG104EF104FT1X	4308	100000	100000	4.9	12.8	40.9	52.2

Note:

- Thermistor resistance tolerance, pullup resistance tolerance, and parasitics are not considered in this table.
- Listed part numbers are for reference only.

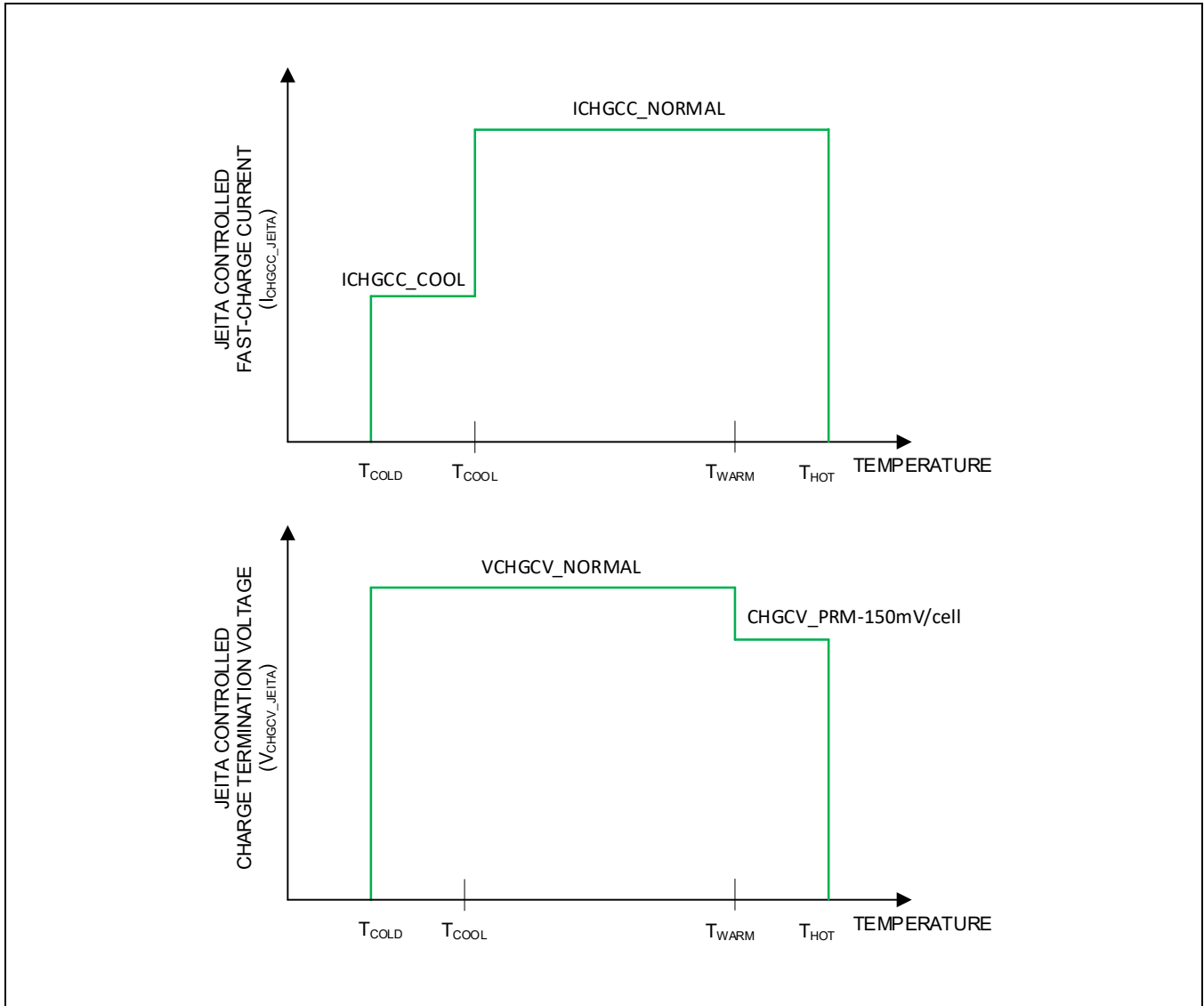

Figure 10. MAX77787J Version JEITA Compliance

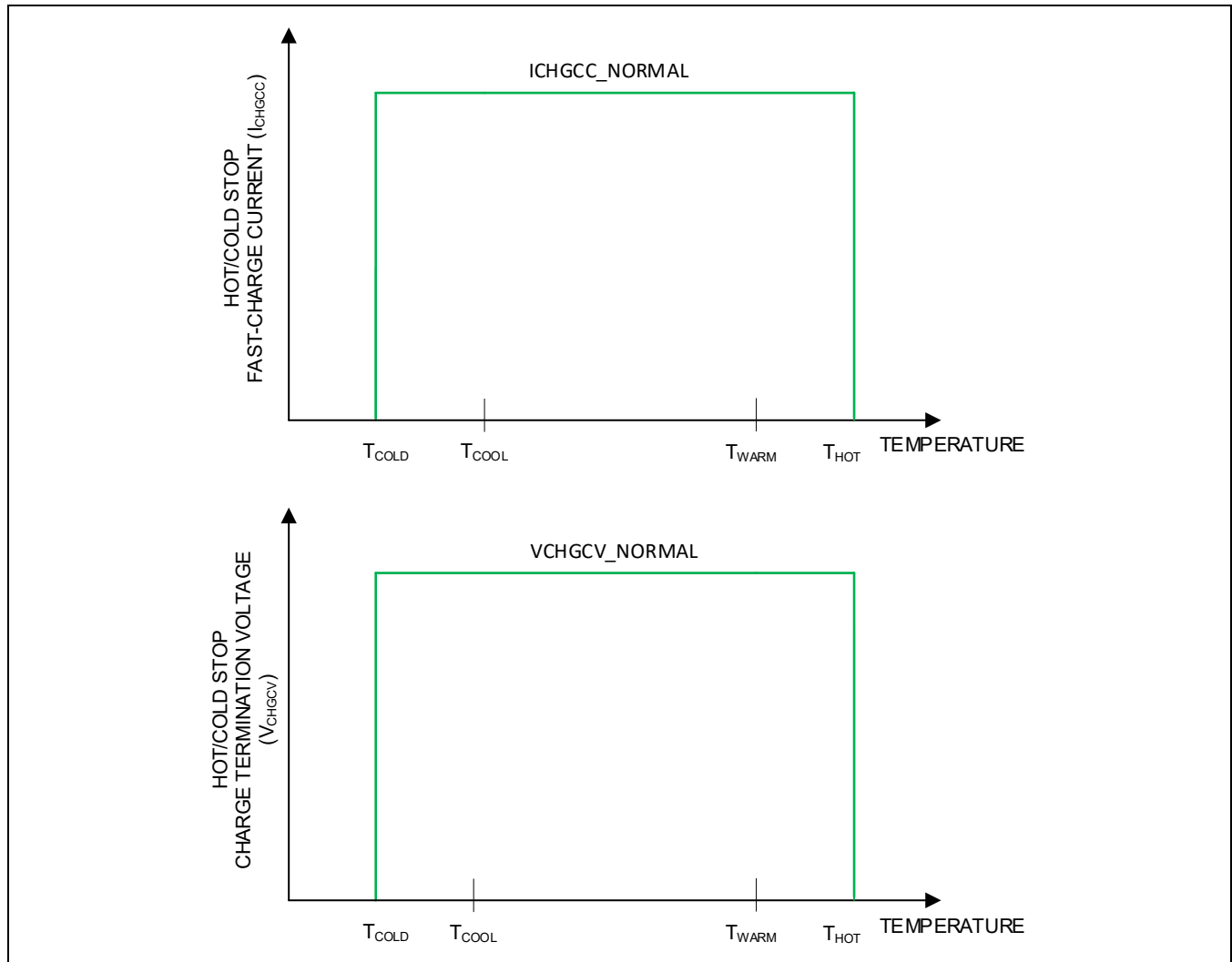

Figure 11. MAX77787H Version Hot/Cold Stop

V_{DD} Internal Supply

V_{DD} is the 1.8V power for the IC charger's analog circuit. V_{DD} is generated from an internal regulator which uses the higher of BATT and internal high voltage regulator as a power input source. V_{DD} has a bypass capacitance of 2.2μF.

CHGENB for Enable and Disable Charging

CHGENB is an input control signal for battery charging with an external logic signal. If CHGENB is driven by high when CHGIN is valid, the battery charging is disabled. CHGENB has an internal 235kΩ pulldown resistor.

STBY for USB Suspend Mode

The host can reduce the IC's CHGIN supply current by driving the STBY pin to high. STBY has an internal 235kΩ pulldown resistor. When STBY is pulled high, the DCDC turns off. When STBY is pulled low, the DCDC is controlled by the power path state machine.

ENBST for OTG Reverse Boost

ENBST is an input control signal for the reverse boost mode with an external logic signal. If ENBST is driven by high, the reverse boost is enabled and the BYP to CHGIN path is closed. It has an internal 235kΩ pulldown resistor. When ENBST sets to high, the IC disconnects R_d from the CC line and provides a 180μA current source to advertise 1.5A OTG current capability to the devices connected.

ENBST and STBY for BYP Reverse Boost

If ENBST and STBY are driven by high, the reverse boost is enabled and delivers power from the battery to the BYP path. The BYP to CHGIN path is open.

Mode Configuration by External Pins

The IC features an operating mode configuration by the combination of external pins when CHGIN is valid. [Table 2](#) lists each mode that the IC is supporting according to the CHGENB, ENBST, and STBY pin's status.

The OTG Reverse Boost Mode and BYP Reverse Boost Mode can only be enabled with the pin configurations in [Table 2](#), when there is no power source connected to the CHGIN pin and when a battery is present.

Table 2. Mode Configuration

CHGENB	ENBST	STBY	CHGIN FET	Q _{BAT}	MODE
1	0	0	ON	OFF	Buck = ON, Charging = OFF
1	0	1	OFF	OFF	Buck = OFF, Charging = OFF
1	1	0	ON	OFF	Both Buck, Boost = OFF, Charging = OFF
1	1	1	OFF	OFF	Both Buck, Boost = OFF, Charging = OFF
0	0	0	ON	ON	Buck = ON, Charging = ON
0	0	1	OFF	ON	Suspend Mode
0	1	0	ON	ON	OTG Reverse Boost Mode
0	1	1	OFF	ON	BYP Reverse Boost Mode

USB BC1.2 Charger Detection**Features**

- D+/D- Charging Signature Detector
- USB BC1.2 Compliant
- SDP, DCP, and CDP Detection
- Detect Proprietary Charger Types
 - Apple 500mA, 1A, 2A, 12W
 - Samsung 2A

Description

The USB charger detection is USB BC1.2 compliant with the ability to automatically detect some common proprietary charger types.

The charger detection state machine follows USB BC1.2 requirements and detects SDP, CDP, and DCP types. The charger detection state machine indicates if D+/D- were found as open then the input current limit is set by R_{INLIM}.

In addition to the USB BC1.2 state machine, the IC also detects a limited number of proprietary charger types (Apple, Samsung, and generic 500mA). The BC1.2 detection block automatically sets the CHGIN input current limiting based on the charger type detection results. If charger type detection results are an unknown charger type, the input current limits are set by R_{INLIM}.

Table 3. BC1.2 Charger Type

USB BC1.2 DETECTED CHARGER TYPE	
INPUT CURRENT LIMIT	CHARGER DETECTED
500mA	No CHGIN
500mA	SDP
1.5A	CDP
1.5A	DCP

Table 4. Proprietary Charger Type

DETECTED PROPRIETARY CHARGER TYPE	
INPUT CURRENT LIMIT	CHARGER DETECTED
500mA	Apple
1A	Apple
2A	Apple
2.4A	Apple 12W
2A	Samsung
Programed by R_{INLIM}	Unknown

USB Type-C CC Detection**Features**

- USB Type-C sink and source support
- CC source detection and automatically sets the input current limit according to source capability
- Source role is supported by the ENBST pin.

CC Description

The IC works as a Sink compliant to USB Type-C rev1.2. The USB Type-C functions are controlled by a logic state machine that follows the USB Type-C requirements. The IC sets the CHGIN input current limit based on the current advertised on the CC wires. Source role is enabled by the ENBST pin. When the source role is enabled, R_d is removed and a $180\mu A$ current source is connected to advertise its current capability.

Detecting Connected Source

When a source is detected, the USB Type-C state machine auto-detects the active CC line. The state machine also auto-detects the source advertised current (500mA, 1.5A, and 3.0A). Upon detection of advertised current through the CC pin, the IC automatically sets the input current limit.

Enable Source Role

ENBST = high enables the IC's source role. The IC disconnects R_d from the CC line and connects a $180\mu A$ current source to advertise the 5V/1.5A power source. The IC enables the reverse boost and supply 5.1V/1.5A through the CHGIN pin.

Applications Information

The MAX77787 reads in the resistor values (R_{IFAST} , R_{VSET} , and R_{INLIM}) once upon power up. It cannot read the values from the potentiometer at run-time. Depending on the use case, customers should populate the resistor values provided in the [Table 5](#) to [Table 7](#). Using any other value can result in an incorrect setting due to tolerances.

Input Current Limit Setting

A resistor (R_{INLIM}) from INLIM to GND programs the charger input current limit. The input current limit setting through a resistor is valid only when the adaptor is detected as unknown. Else, the input current limit is programmed by D+/D- detection and CC detection results.

Table 5. Input Current Limit Setting

R_{INLIM} (k Ω)	INLIM (mA)
Unconnected	500
24.9	500
22.6	600
20.5	700
18.7	800
16.9	900
15.4	1000
14	1150
12.4	1300
11	1500
9.53	1750
8.2	2000
6.65	2250
5.23	2500
3.6	2700
2.4	3000

Termination Voltage Setting

The default charge termination voltage is programmed with the resistance from VSET to GND. See [Table 6](#).

Table 6. Charge Termination Voltage Setting Input (VSET) Setting

R_{VSET} (k Ω)	CV (V)
Unconnected	3.60
24.9	3.60
22.6	3.70
20.5	3.80
18.7	3.90
16.9	4.00
15.4	4.10
14	4.15

RVSET (k Ω)	CV (V)
12.4	4.20
11	4.25
9.53	4.30
8.2	4.35
6.65	4.40
5.23	4.45
3.6	4.50
2.4	4.55

Fast-Charge Current and TOPOFF Current Setting

While a valid input source is present, the battery charger attempts to charge the battery with a fast-charge current determined by the resistance from I_{FAST} to GND. The top-off current is matched to the fast-charge current, [Table 7](#) shows resistance values which correspond to target I_{FAST} and I_{TOPOFF} values.

Table 7. Fast-Charge Current and Top-off Current Setting

RESISTANCE (k Ω)	I _{FAST} (mA)	I _{TOPOFF} (mA)
Unconnected	3150	150
24.9	3150	150
22.6	3000	150
20.5	2800	125
18.7	2500	125
16.9	2400	125
15.4	2200	100
14	2000	100
12.4	1800	75
11	1500	75
9.53	1400	75
8.2	1200	50
6.65	1000	50
5.23	800	50
3.6	600	50
2.4	500	50

Charger Status Outputs

Input Status (INOKB)

INOKB is an open-drain and active-low output that indicates input status. If a valid input source is inserted and the buck converter starts switching, INOKB pulls low. When the reverse boost is enabled, INOKB pulls low to indicate 5V output from CHGIN.

INOKB can be used as a logic output for the system processor by adding a 200k Ω pullup resistor to the system IO voltage.

INOKB can be also used as a LED indicator driver by adding a current limit resistor and a LED to SYS.

Charging Status (STAT)

STAT is an open-drain and active-low output that indicates charge status. STAT status changes as shown in [Table 8](#).

Table 8. STAT Output Per Charging Status

CHARGING STATUS	STAT	LOGIC STATE	CHARGE STATUS LED
No input	High impedance	High	Off
Trickle, pre-charge, fast charge	Repeat low and high impedance with 1Hz, 50% duty cycle	After an external diode and a capacitor rectifier, high	Blinking with 1Hz, 50% duty cycle
Top-off and done	Low	Low	Solid on
Faults	High impedance	High	Off

STAT can be used as a logic output for the system processor by adding a 200kΩ pullup resistor to system IO voltage and a rectifier (a diode and a capacitor).

STAT also can be used as a LED indicator driver by adding a current limit resistor and a LED to SYS.

D+/D- Multiplexer (Optional)

USB D+/D- lines, which are used for the detection of BC1.2 and proprietary TA (Travel Adaptor)s, can be used for data communication. If an MCU handles this communication in the target system, the D+/D- lines can be connected to the IC and the MCU like [Figure 12](#). As shown in [Figure 12](#), switchers are required for each D+ and D- lines to guarantee Hi-Z for the connections to MCU to avoid the wrong detections of TAs. It is recommended to connect the INOKB of the IC to the MCU in this configuration so that the IC can signal the completion of the detection to the MCU. Once the MCU receives a valid INOKB signal, it can switch the D+/D- lines from the IC to the MCU for data communication.

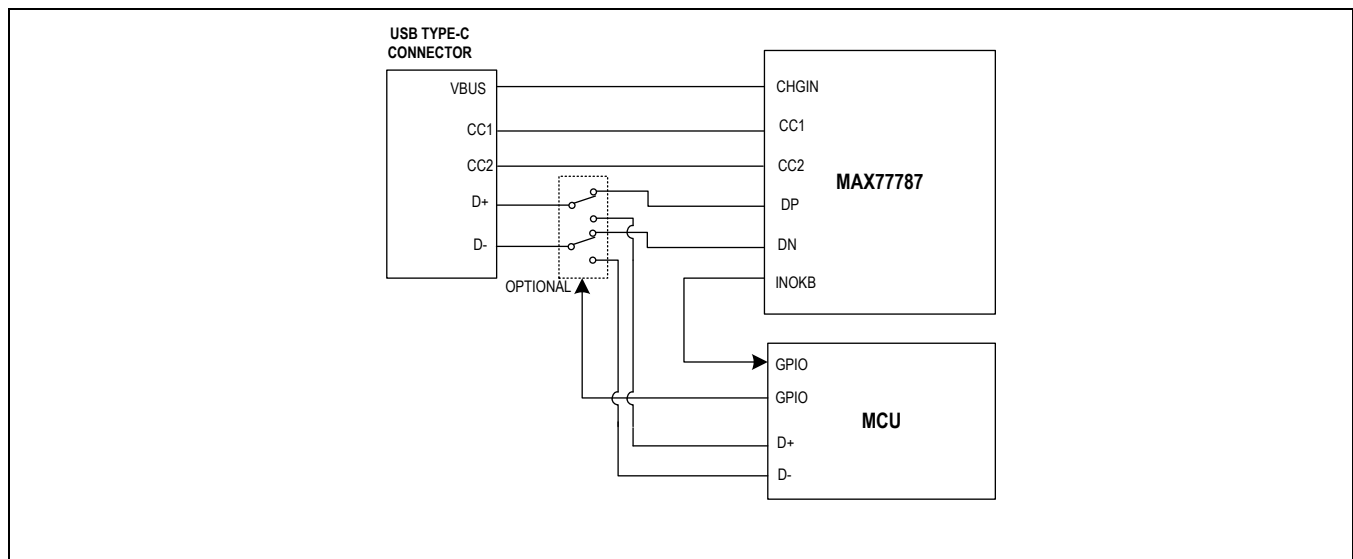

Figure 12. D+/D- Connections in a Reference System

Non-USB Type Power Source

In an application where the power source is not USB, all the USB-related pins such as CC1, CC2, DP, and DN should be left NC (not connected). In this case, the input current to the IC is limited by the R_{INLIM} setting

Recommended PCB Layout and Routing

Place all bypass capacitors for CHGIN, BYP, SYS, V_{DD} , and BATT as close as possible to the IC. Connect the battery to BATT as close as possible to the IC to provide accurate battery voltage sensing. Provide a large copper ground plane to allow the PGND pad to sink heat away from the device. Use wide and short traces for high current connections such as CHGIN, BYP, SYS, and BATT to minimize voltage drops. The IC has two kinds of ground pins, which are PGND and

GND. Care should be taken to connect PGND since it is a switching node ground of the charger buck. It should be tied to the ground of the SYS capacitor and BYP capacitor and connected to the ground plane directly without sharing other ground. The GND can be connected to the ground plane.

Figure 13 is a recommended placement and layout guide.

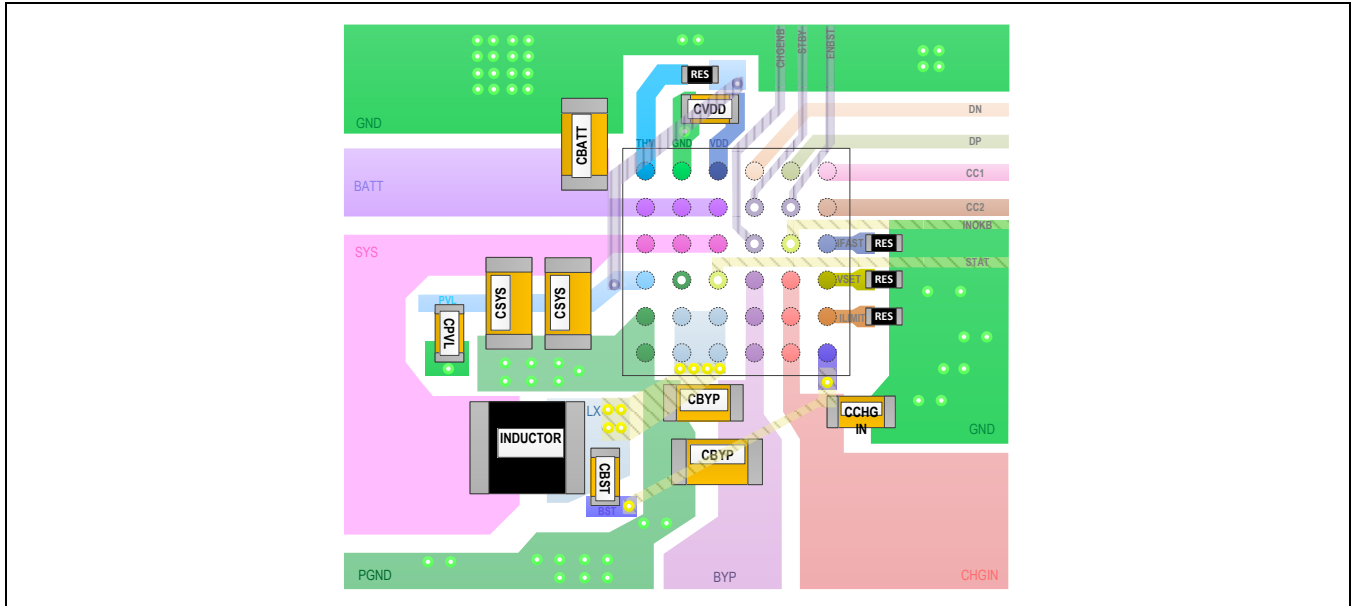

Figure 13. Recommended Placement and Layout

Inductor Selection

The IC's control scheme requires an external inductor from 0.47µH to 1µH for proper operation.

Table 9. Recommended Inductors

MANUFACTURER	PART NUMBER	INDUCTANCE (µH)	ISAT(TYP) (A)	IRMS(TYP) (A)	DCR (TYP) (mΩ)	SIZE (L x W x T) (mm)
SEMCO	CIGT252008LMR47MNE	0.47	5.5	4.5	24	2.5 x 2.0 x 0.8
SEMCO	CIGT252010LMR47MNE	0.47	6	4.5	24	2.5 x 2.0 x 1.0
SEMCO	CIGT201610EHR47MNE	0.47	5.9	5	18	2.0 x 1.6 x 1.0
CYNTEC	HTGH25201T-R47MSR-68	0.47	6.6	5.6	16.5	2.5 x 2.0 x 1.0

Capacitor Selection

All capacitors should be X5R dielectric or better. Be aware that multi-layer ceramic capacitors have large-voltage coefficients. Before selecting capacitors, check sufficient voltage rating and derated capacitance at max operating voltage condition. [Table 10](#) shows proper capacitors after considering the derating and operating voltage.

Table 10. Capacitor Selections

PIN	TYPE
CHGIN Capacitor	2.2 μ F/16V
BYP Capacitor	10 μ F + 22 μ F/16V
SYS Capacitor	2x10 μ F/10V
BATT Capacitor	10 μ F/10V
V _{DD} Capacitor	2.2 μ F/10V
PVL Capacitor	2.2 μ F/10V
BST Capacitor	100nF/6.4V

Typical Application Circuit

A typical application circuit consists of the device as a single cell battery charger for Li-Ion battery used in a wide range of portable devices. External USB switch is optional for the USB2.0 and USB3.x communication between MCU and the devices in the system. To set the input current limit to SDP 900mA which is the USB3.x device V_{BUS} current capability, MCU shall send in a pulse on the INLIM pin with a pulse width greater than 123µs to set the 900mA option, so that the IC configures input current limit to 900mA.

The procedure for the SDP 900mA INLIM setting is as follows:

- INOKB pulls low when detection is done as SDP.
- MCU controls USB Switch.
- MCU starts enumeration to the USB device attached.
- MCU sends a pulse signal through GPIO1 to the INLIM pin when USB3.x device is recognized.

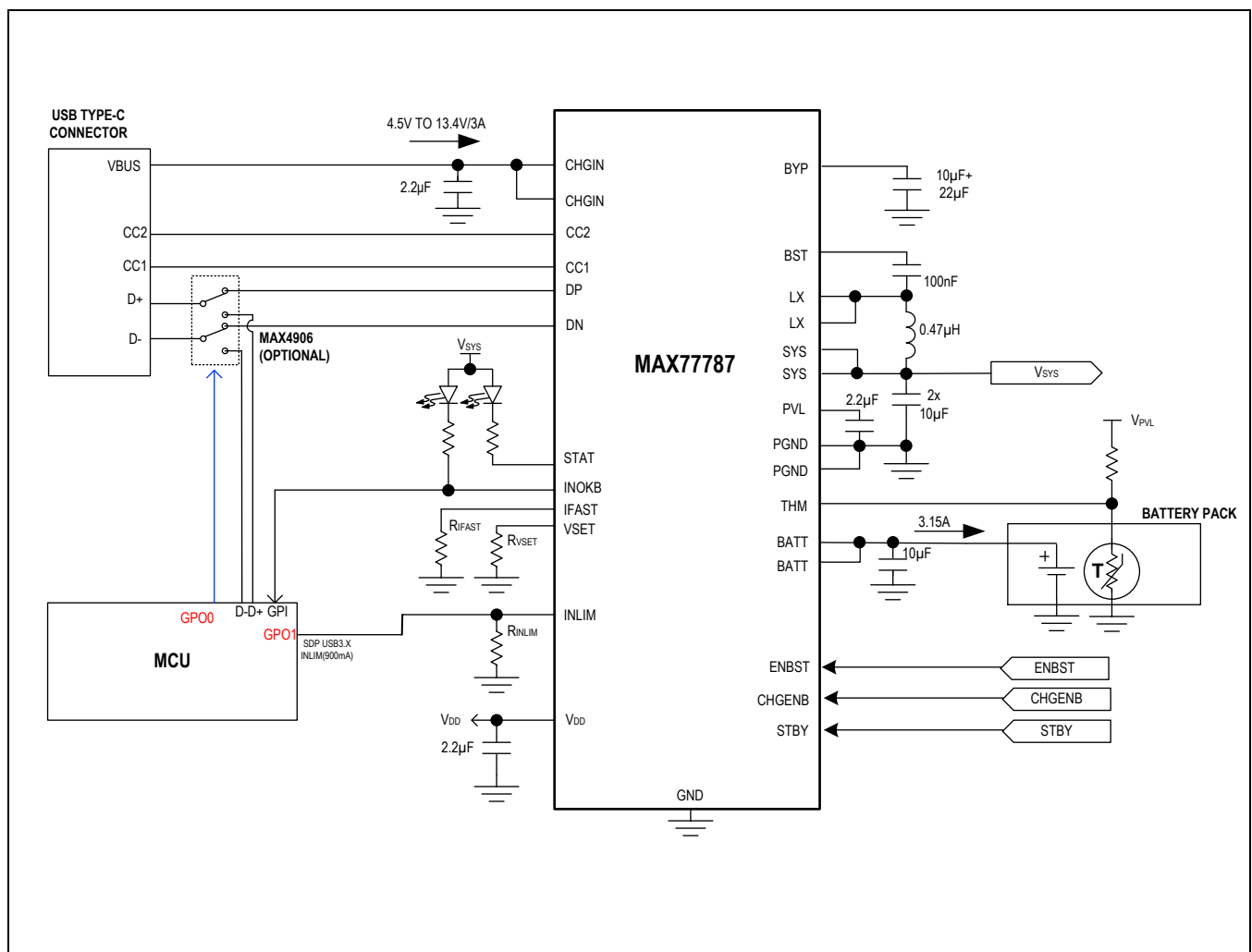

Ordering Information

PART NUMBER	TEMP RANGE	PIN-PACKAGE	THM	BATTERY CHEMISTRY
MAX77787JEWX+	-40°C to +85°C	WLP	JEITA	Li-ion Li-polymer
MAX77787JEWX+ T	-40°C to +85°C	WLP	JEITA	Li-ion Li-polymer
MAX77787HEWX+	-40°C to +85°C	WLP	HOT/COLD STOP	LiFePO4
MAX77787HEWX+ T	-40°C to +85°C	WLP	HOT/COLD STOP	LiFePO4

+Denotes a lead(Pb)-free/RoHS-compliant package.

T = Tape and reel.

Revision History

REVISION NUMBER	REVISION DATE	DESCRIPTION	PAGES CHANGED
0	4/22	Release for Market Intro	—
1	5/23	Added RIFAST, RVSET, and RINLIM read in information in the Applications Information section	35

