

REVISIONS

P	LTR	DESCRIPTION	DATE	DWN	APVD
A		RELEASED PER ECO-20-008335	15JUN2020	BKW	SW
B		RELEASED PER ECN-22-190035	14DEC2022	CX	DZ
C		REVISED PER ECR-23-169880	21MAR2023	MV	DZ

1. MATERIAL: PA  
COLOR - BLACK

2. MATING CONNECTOR P/N'S:  
PLUG HSG - \*-2232826-\*

3. COUNTERPART: 2350224

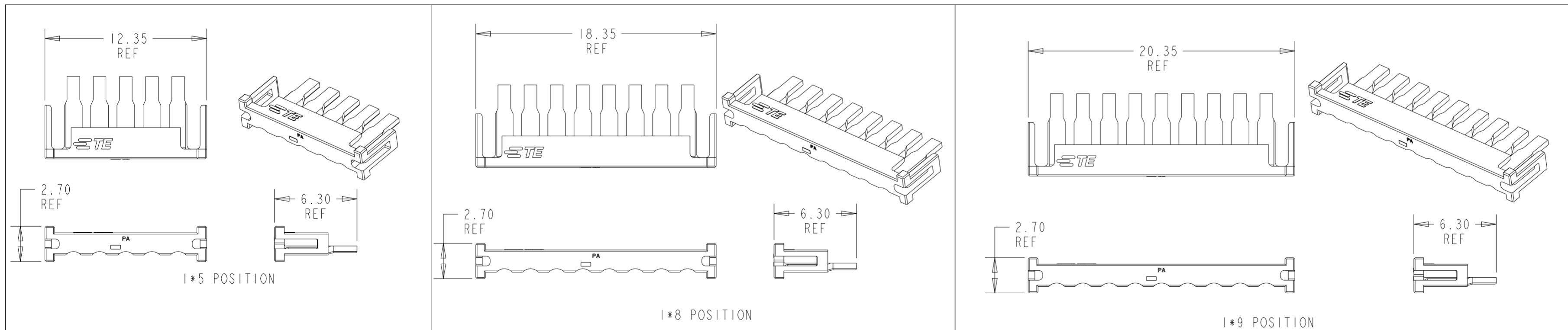
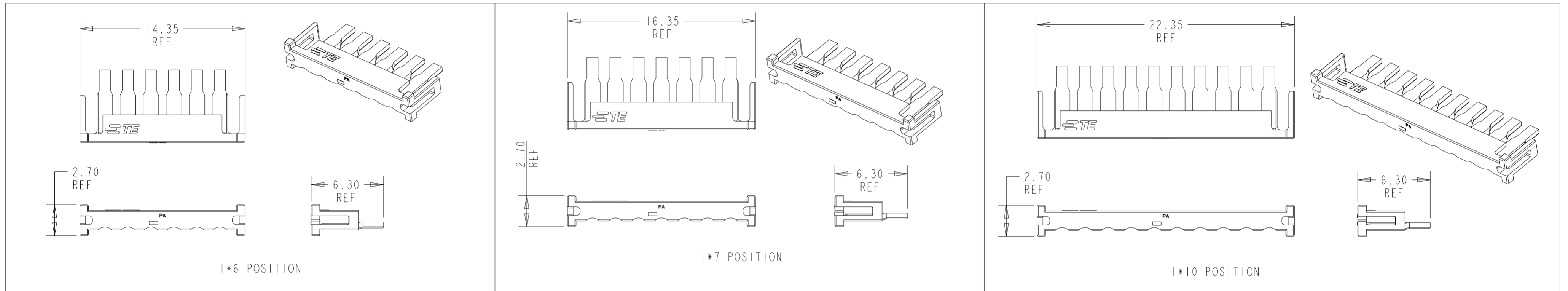
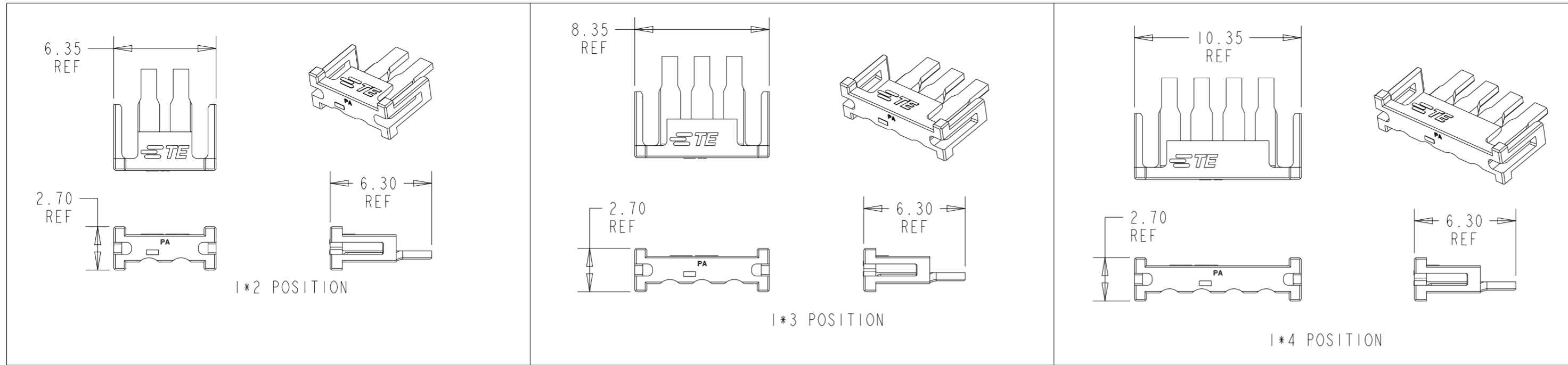

1*10	1-2357686-0
1*9	2357686-9
1*8	2357686-8
1*7	2357686-7
1*6	2357686-6
1*5	2357686-5
1*4	2357686-4
1*3	2357686-3
1*2	2357686-2
POSITIONS	PART NUMBER

THIS DRAWING IS A CONTROLLED DOCUMENT.

DWN 20 JUN 2019  
B. WEAVER

CHK 20 JUN 2019  
C. YI

APVD 20 JUN 2019  
T. BENCHOFF

PRODUCT SPEC

108-143160

APPLICATION SPEC

114-143160

WEIGHT -

CUSTOMER DRAWING

TE Connectivity		RESTRICTED TO	
NAME TPA, SGI 2.0		-	
SIZE A2	CAGE CODE 00779	DRAWING NO. C-2357686	REV C
SCALE 4:1	SHEET 1	OF 1	REV C

DIMENSIONS:		TOLERANCES UNLESS OTHERWISE SPECIFIED:	
mm		0 PLC ±	
		1 PLC ±	
		2 PLC ±0.2	
		3 PLC ±	
		4 PLC ±	
		ANGLES ±	
		FINISH -	
		-	