

## Evaluation Board for the **ADP5091** Demonstration Platform for Energy Harvesting

### FEATURES

- Plug and play energy harvesting platform**
- Compatible with Analog Devices, Inc., wireless sensor network (WSN) platform**
- Solar panel harvester included**
- One regulated output with programmable output voltage**
- RoHS compliant**

### GENERAL DESCRIPTION

The **ADP5091** demonstration platform is a plug and play evaluation board (**ADP5091-2-EVALZ**) for energy harvesting. The evaluation board includes the photovoltaic (PV) panel and all of the power management to enable devices to be powered using energy harvesting. It is based on the Alta Device PV cell and the **ADP5091** energy harvesting power management IC.

The demonstration platform converts light energy to electrical energy. The PV panel converts the light to 0.8 V electrical energy. The **ADP5091** boosts the input voltage from 0.8 V to 3.5 V and stores the energy in a supercapacitor.

The **ADP5091** has a regulated output with programmable output voltage. By combining a low dropout (LDO) regulator and a boost regulator, it offers a more compatible output voltage than the output of a main boost regulator. The Alta Device PV cell is a light harvesting, dye sensitized PV cell. It is optimized for indoor environments, where lux levels of 200 lux to 1000 lux are typical.

The **ADP5091** is an ultralow power, synchronous, boost dc-to-dc regulator. The **ADP5091** runs from input voltages of 0.38 V to 3.3 V and provides a high efficiency solution with integrated power switch, synchronous rectifier, battery management, and one regulated output. The demonstration platform provides an easy way to evaluate the device.

Full details about the **ADP5091** are available in the product data sheet, which should be consulted in conjunction with this user guide when using the **ADP5091-2-EVALZ**.

The system also plugs directly into the Analog Devices WSN demonstration platform.

This user guide describes how to set up the board and how to use it for powering loads.

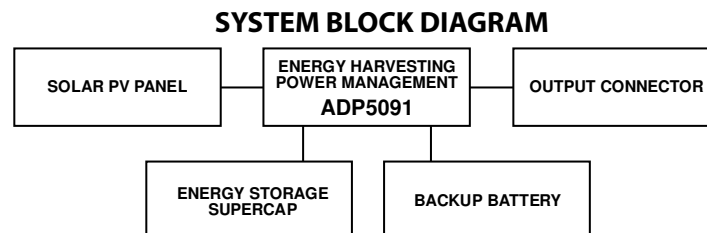

Figure 1.

14167-001

**TABLE OF CONTENTS**

Features .....	1	Power Management of the Output (LDO).....	4
General Description .....	1	J4 Output Connector .....	5
System Block Diagram .....	1	Evaluation Board Schematics.....	6
Revision History .....	2	Evaluation Board Layout .....	7
Evaluation Board Quick Start Guide .....	3	Ordering Information.....	8
Evaluation Board Hardware .....	4	Bill of Materials.....	8

**REVISION HISTORY**

**5/2016—Revision 0: Initial Version**

## EVALUATION BOARD QUICK START GUIDE

This section explains how to connect the solar panel to the evaluation board and how to configure the evaluation board to start up and run.

1. Connect the 10-pin connector on the solar panel to the J3 10-pin connector on the evaluation board, as shown in Figure 2.

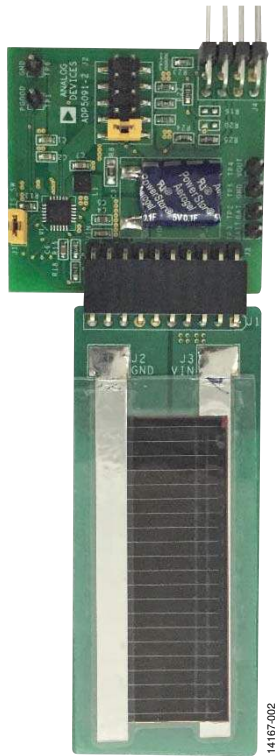

Figure 2. ADP5091-2-EVALZ Hardware

2. Connect J2\_1 and J2\_2 on the evaluation board, as shown in Figure 3.
3. Place the system in a bright environment. Monitor the voltage on the supercapacitor using the TP3 (BATT) and TP5 (GND) test points.
4. The output is available on J4\_1 on the evaluation board.

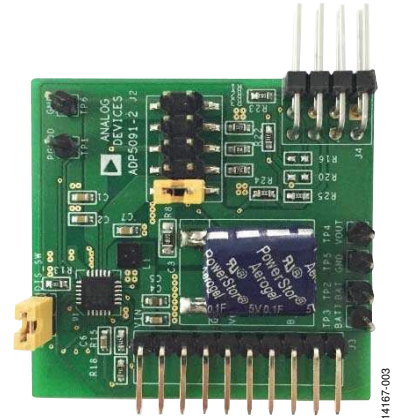

Figure 3. Jumper Setup

## EVALUATION BOARD HARDWARE

### POWER MANAGEMENT OF THE OUTPUT (LDO)

The ADP5091 has an additional regulated output containing an LDO and a boost. On this evaluation board, the boost is always shut down. With the options of different resistor values, the LDO can generate different output voltages. Table 1 shows the jumper connections and the corresponding output voltage on the ADP5091-2-EVALZ. See the Evaluation Board Schematic section for more details.

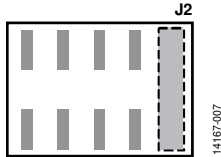

Figure 4. Jumper Position on Evaluation Board for Setting 1

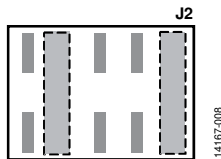

Figure 5. Jumper Position on Evaluation Board for Setting 2

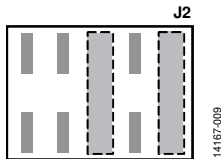

Figure 6. Jumper Position on Evaluation Board for Setting 3

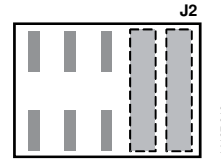

Figure 7. Jumper Position on Evaluation Board for Setting 4

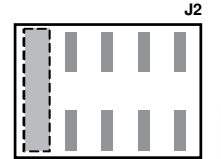

Figure 8. Jumper Position on Evaluation Board for Setting 5

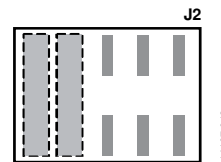

Figure 9. Jumper Position on Evaluation Board for Setting 6

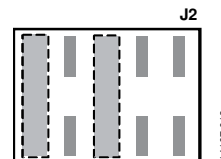

Figure 10. Jumper Position on Evaluation Board for Setting 7

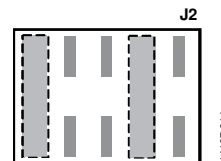

Figure 11. Jumper Position on Evaluation Board for Setting 8

Table 1. Power Management of Sensor Nodes<sup>1</sup>

Setting	V <sub>OUT</sub> (V)	REG_OUT (V)	Jumper Position
1	V <sub>SYS</sub> <sup>2</sup>	2.5 V	J2_9 connected to J2_10 (see Figure 4)
2	V <sub>SYS</sub> <sup>2</sup>	3.3 V	J2_3 connected to J2_4, J2_9 connected to J2_10 (see Figure 5)
3	V <sub>SYS</sub> <sup>2</sup>	3 V	J2_5 connected to J2_6, J2_9 connected to J2_10 (see Figure 6)
4	V <sub>SYS</sub> <sup>2</sup>	2.8 V	J2_7 connected to J2_8, J2_9 connected to J2_10 (see Figure 7)
5	2.5 V	2.5 V	J2_1 connected to J2_2 (see Figure 8)
6	3.3 V	3.3 V	J2_1 connected to J2_2, J2_3 connected to J2_4 (see Figure 9)
7	3 V	3 V	J2_1 connected to J2_2, J2_5 connected to J2_6 (see Figure 10)
8	2.8 V	2.8 V	J2_1 connected to J2_2, J2_7 connected to J2_8 (see Figure 11)

<sup>1</sup> Do not connect both J2\_1 to J2\_2 and J2\_9 to J2\_10 at the same time.

<sup>2</sup> V<sub>SYS</sub> means the voltage on the SYS pin.

## J4 OUTPUT CONNECTOR

The J4 output connector (see Figure 12) connects the evaluation board to the load. In addition to providing power, J4 also provides other interface connections that allow more interaction between the evaluation board and the host microcontroller unit (MCU) on the load. The evaluation board is directly compatible with the Analog Devices WSN demonstration boards. Table 2 shows the pinout of the J4 output connector and a brief description of the pin functions.

**Table 2. J4 Output Connector**

Pin No.	Mnemonic	Description
1	VOUT	Output voltage supply from the evaluation board to the load
2	PGOOD	PGOOD output signal from the <a href="#">ADP5091</a>
3	GND	Ground
4	DIS_SW	DIS_SW input signal to the <a href="#">ADP5091</a>
5	BATT	Supercapacitor voltage (for battery monitoring)
6	EN	Enable LDO
7	BACK_UP	Backup voltage (for battery monitoring)
8	REG_OUT	Regulated output voltage supply from the evaluation board to the load

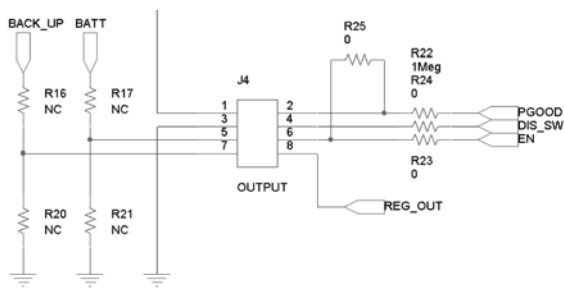

Figure 12. J4 Output Connector

A detailed description of each J4 output connector pin follows:

- The VOUT pin (Pin 1) is the output voltage that the evaluation board delivers to the load.
- The [ADP5091](#) has a programmable PGOOD signal. When the PGOOD threshold is reached, the [ADP5091](#) sets the PGOOD pin (Pin 2) high. It is connected to the host MCU general-purpose input/output (GPIO) input. See the [ADP5091](#) data sheet for more detailed information on this function.
- The GND pin (Pin 3) is the ground connection for the [ADP5091](#).
- Connect the DIS\_SW pin (Pin 4) to the host MCU GPIO output. If the host MCU requires the [ADP5091](#) to temporarily halt the switching regulator function, set this pin high. Remove the J1 jumper at the same time, if this function needs to be used. See the [ADP5091](#) data sheet for more detailed information on this function.
- Connect the BATT pin (Pin 5) to the analog input of the host MCU to monitor the voltage on the supercapacitor of the [ADP5091-2-EVALZ](#). Populating R17 and R21 creates a resistor divider for cases where the MCU analog input range is lower than the supercapacitor voltage.
- The EN pin (Pin 6) is the enable control signal for the regulated output. Connect this pin to the host MCU GPIO output to enable or disable the LDO. Also remove R25 if this function needs to be used.
- Connect the BACK\_UP pin (Pin 7) to the analog input of the host MCU to monitor the voltage on the backup battery of the [ADP5091-2-EVALZ](#). Populating R16 and R20 creates a resistor divider for cases where the MCU analog input range is lower than the supercapacitor voltage.
- The REG\_OUT pin provides an additional output with a different voltage than VOUT when VOUT is using bypass mode (see Table 1).

14167-015

# EVALUATION BOARD SCHEMATICS

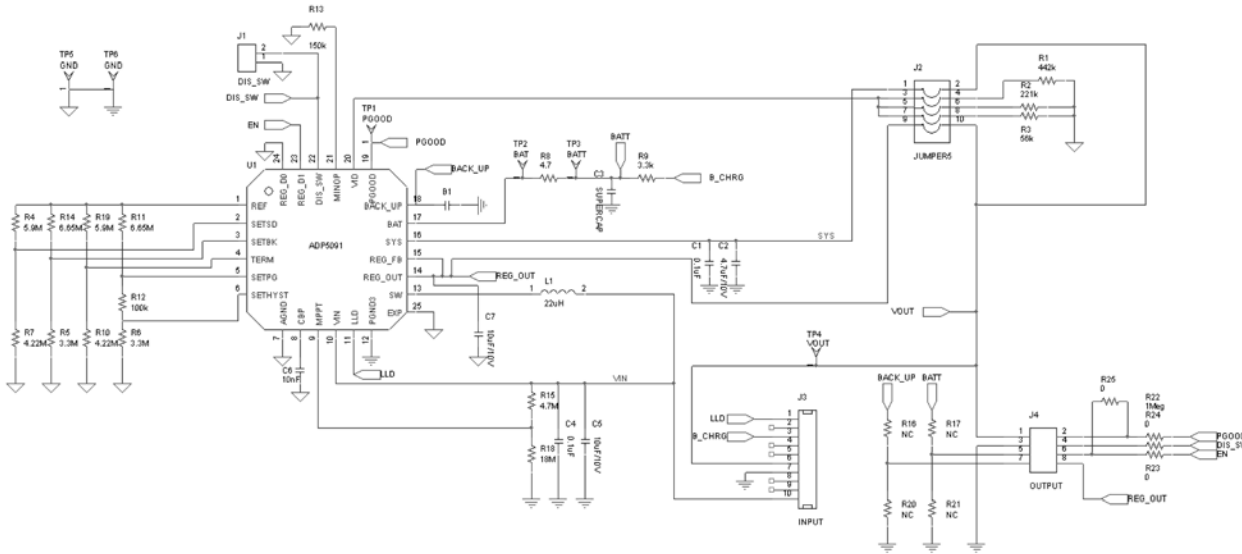

Figure 13. ADP5091-2-EVALZ Evaluation Board Schematic

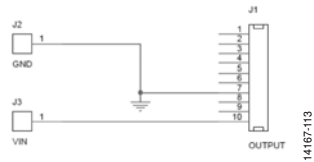

Figure 14. ADP5091-2-EVALZ PV Board Schematic

14167-004

# EVALUATION BOARD LAYOUT

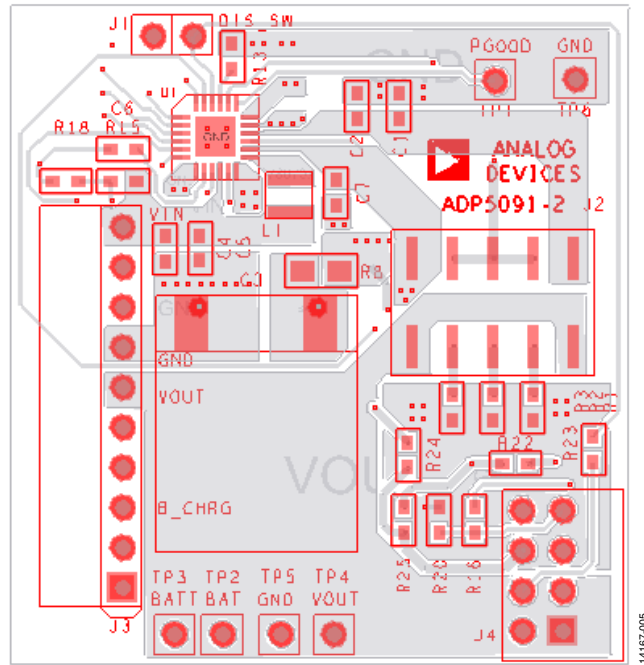

Figure 15. Top Assembly

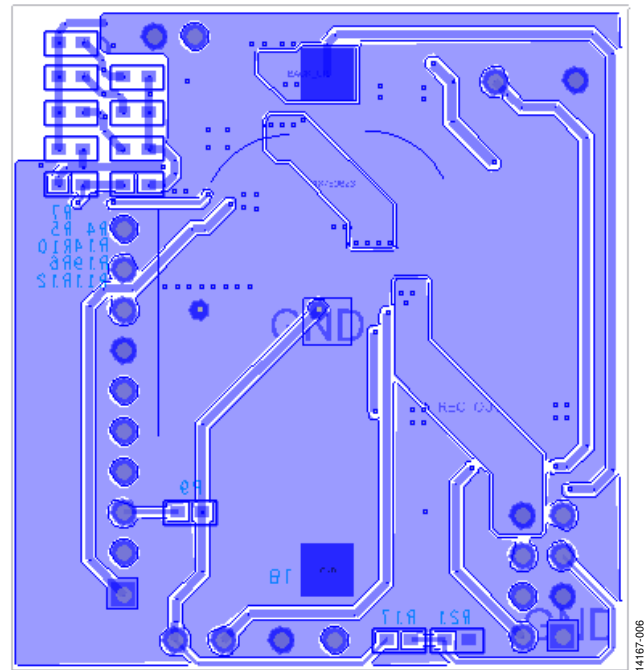

Figure 16. Bottom Assembly

## ORDERING INFORMATION

### BILL OF MATERIALS

Table 3. Bill of Materials of Evaluation Board

Qty	Reference Designator	Description	Part Number	Vendor
1	B1	CR2032 holder	BC2032-F1	Memory Protection Devices
2	C1, C4	0.1 $\mu$ F capacitors, C0603	GRM188R71H104KA93	Murata
2	C2, C5	4.7 $\mu$ F, 10 V capacitors, C0603	GRM21BR61A475KA73	Murata
1	C3	Supercapacitor, 12 $\times$ 12	PB-5R0H104-R	Cooper Bussmann
1	C6	10 nF capacitor, C0603	GRM188R71H103KA01	Murata
1	C7	10 $\mu$ F, 10 V capacitors, C0603	GRM188R61A106KE69D	Murata
1	J1	DIS_SW jumper, SIP2	61304011121	Würth Elektronik
1	J2	V <sub>OUT</sub> and REG_OUT setting jumper, SIP10_dual	61031021121	Würth Elektronik
1	J3	Input jumper, SIP10_BtoB	61301011021	Würth Elektronik
1	J4	Output jumper, SIP8_2rows	9-103324-0	TE Connectivity
1	L1	22 $\mu$ H inductor, 3 $\times$ 3	EPL3015-223ML, 744025220	Coilcraft, Würth Elektronik
1	R1	442 k $\Omega$ resistor, R0603	CRCW0603442KFKEA	Vishay Dale
1	R2	221 k $\Omega$ resistor, R0603	CRCW0603221KFKEA	Vishay Dale
1	R3	56 k $\Omega$ resistor, R0603	CRCW060356K0FKEA	Vishay Dale
2	R4, R19	5.9 M $\Omega$ resistor, R0603	CRCW06035M90FKEA	Vishay Dale
2	R5, R6	3.3 M $\Omega$ resistor, R0603	CRCW06033M30FKEA	Vishay Dale
2	R7, R10	4.22 M $\Omega$ resistors, R0603	CRCW06034M22FKEA	Vishay Dale
1	R8	4.7 $\Omega$ resistor, R0805	CRCW08054R70JNEAIF	Vishay Dale
1	R9	3.3 k $\Omega$ resistor, R0603	CRCW06033K30FKEA	Vishay Dale
2	R11, R14	6.65 M $\Omega$ resistor, R0603	CRCW06036M65FKEA	Vishay Dale
1	R12	100 k $\Omega$ resistor, R0603	CRCW0603100KFKEA	Vishay Dale
1	R13	150 k $\Omega$ resistor, R0603	CRCW0603150KFKEA	Vishay Dale
1	R15	4.7 M $\Omega$ resistor, R0603	CRCW06034M70FKEA	Vishay Dale
4	R16, R17, R20, R21	No connect (NC) resistors, R0603	Not applicable	Not applicable
1	R18	18 M $\Omega$ resistor, R0603	CRCW060318M0JPEAHR	Vishay Dale
1	R22	1 M $\Omega$ resistor, R0603	CRCW06031M00FKEA	Vishay Dale
3	R23, R24, R25	0 $\Omega$ resistor, R0603	CRCW06030000Z0EA	Vishay Dale
1	TP1	PGOOD test point, SIP1	61304011121	Würth Elektronik
1	TP2	BAT test point, SIP1	61304011121	Würth Elektronik
1	TP3	BATT test point, SIP1	61304011121	Würth Elektronik
1	TP4	VOUT test points, SIP1	61304011121	Würth Elektronik
2	TP5, TP6	GND test points, SIP1	61304011121	Würth Elektronik
1	U1	ADP5091 24-lead LFCSP	ADP5091ACPZ-1-R7	Analog Devices

Table 4. Bill of Materials of PV Board

Qty	Reference Designator	Description	Part Number	Vendor
1	J1	Output jumper, SIP10	613010143121	Würth Elektronik
1	J2	Input 1 jumper, PV_INPUT	Not applicable	Alta Device
1	J3	Input 2 jumper, PV_INPUT	Not Applicable	Alta Device



## NOTES



### ESD Caution

**ESD (electrostatic discharge) sensitive device.** Charged devices and circuit boards can discharge without detection. Although this product features patented or proprietary protection circuitry, damage may occur on devices subjected to high energy ESD. Therefore, proper ESD precautions should be taken to avoid performance degradation or loss of functionality.

### Legal Terms and Conditions

By using the evaluation board discussed herein (together with any tools, components documentation or support materials, the "Evaluation Board"), you are agreeing to be bound by the terms and conditions set forth below ("Agreement") unless you have purchased the Evaluation Board, in which case the Analog Devices Standard Terms and Conditions of Sale shall govern. Do not use the Evaluation Board until you have read and agreed to the Agreement. Your use of the Evaluation Board shall signify your acceptance of the Agreement. This Agreement is made by and between you ("Customer") and Analog Devices, Inc. ("ADI"), with its principal place of business at One Technology Way, Norwood, MA 02062, USA. Subject to the terms and conditions of the Agreement, ADI hereby grants to Customer a free, limited, personal, temporary, non-exclusive, non-sublicensable, non-transferable license to use the Evaluation Board FOR EVALUATION PURPOSES ONLY. Customer understands and agrees that the Evaluation Board is provided for the sole and exclusive purpose referenced above, and agrees not to use the Evaluation Board for any other purpose. Furthermore, the license granted is expressly made subject to the following additional limitations: Customer shall not (i) rent, lease, display, sell, transfer, assign, sublicense, or distribute the Evaluation Board; and (ii) permit any Third Party to access the Evaluation Board. As used herein, the term "Third Party" includes any entity other than ADI, Customer, their employees, affiliates and in-house consultants. The Evaluation Board is NOT sold to Customer; all rights not expressly granted herein, including ownership of the Evaluation Board, are reserved by ADI. CONFIDENTIALITY. This Agreement and the Evaluation Board shall all be considered the confidential and proprietary information of ADI. Customer may not disclose or transfer any portion of the Evaluation Board to any other party for any reason. Upon discontinuation of use of the Evaluation Board or termination of this Agreement, Customer agrees to promptly return the Evaluation Board to ADI. ADDITIONAL RESTRICTIONS. Customer may not disassemble, decompile or reverse engineer chips on the Evaluation Board. Customer shall inform ADI of any occurred damages or any modifications or alterations it makes to the Evaluation Board, including but not limited to soldering or any other activity that affects the material content of the Evaluation Board. Modifications to the Evaluation Board must comply with applicable law, including but not limited to the RoHS Directive. TERMINATION. ADI may terminate this Agreement at any time upon giving written notice to Customer. Customer agrees to return to ADI the Evaluation Board at that time. LIMITATION OF LIABILITY. THE EVALUATION BOARD PROVIDED HEREUNDER IS PROVIDED "AS IS" AND ADI MAKES NO WARRANTIES OR REPRESENTATIONS OF ANY KIND WITH RESPECT TO IT. ADI SPECIFICALLY DISCLAIMS ANY REPRESENTATIONS, ENDORSEMENTS, GUARANTEES, OR WARRANTIES, EXPRESS OR IMPLIED, RELATED TO THE EVALUATION BOARD INCLUDING, BUT NOT LIMITED TO, THE IMPLIED WARRANTY OF MERCHANTABILITY, TITLE, FITNESS FOR A PARTICULAR PURPOSE OR NON-INFRINGEMENT OF INTELLECTUAL PROPERTY RIGHTS. IN NO EVENT WILL ADI AND ITS LICENSORS BE LIABLE FOR ANY INCIDENTAL, SPECIAL, INDIRECT, OR CONSEQUENTIAL DAMAGES RESULTING FROM CUSTOMER'S POSSESSION OR USE OF THE EVALUATION BOARD, INCLUDING BUT NOT LIMITED TO LOST PROFITS, DELAY COSTS, LABOR COSTS OR LOSS OF GOODWILL. ADI'S TOTAL LIABILITY FROM ANY AND ALL CAUSES SHALL BE LIMITED TO THE AMOUNT OF ONE HUNDRED US DOLLARS (\$100.00). EXPORT. Customer agrees that it will not directly or indirectly export the Evaluation Board to another country, and that it will comply with all applicable United States federal laws and regulations relating to exports. GOVERNING LAW. This Agreement shall be governed by and construed in accordance with the substantive laws of the Commonwealth of Massachusetts (excluding conflict of law rules). Any legal action regarding this Agreement will be heard in the state or federal courts having jurisdiction in Suffolk County, Massachusetts, and Customer hereby submits to the personal jurisdiction and venue of such courts. The United Nations Convention on Contracts for the International Sale of Goods shall not apply to this Agreement and is expressly disclaimed.

©2016 Analog Devices, Inc. All rights reserved. Trademarks and registered trademarks are the property of their respective owners.  
UG14167-0-5/16(0)



[www.analog.com](http://www.analog.com)