

2176

PART NO.	ENG. NO.	DESCRIPTION
05-06-0301	2176-T	TIN PLATE
05-06-0303	2176-AT	WITHOUT DETENT, TIN PLATED
NOT TOOLED	X-2176-999A	WITHOUT DETENT, UNPLATED
05-06-0302	2176-(P90)DL	WITH DETENT, PLATED, LOOSE
05-06-0304	2176-(P90)DAL	WITHOUT DETENT, PLATED, LOOSE

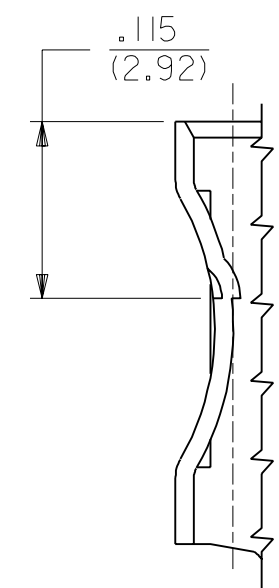
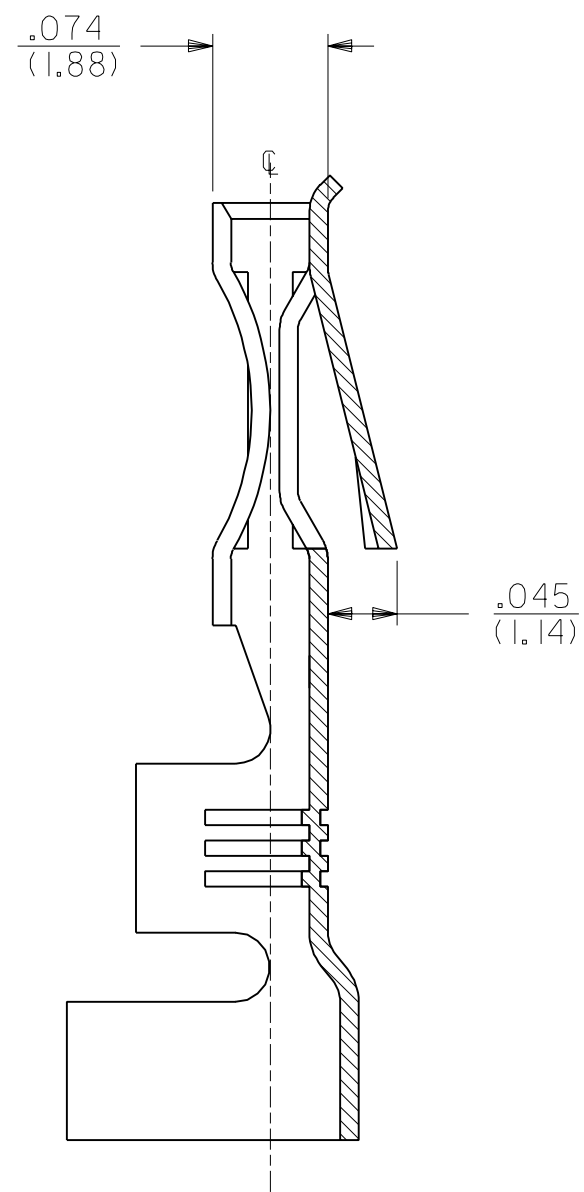
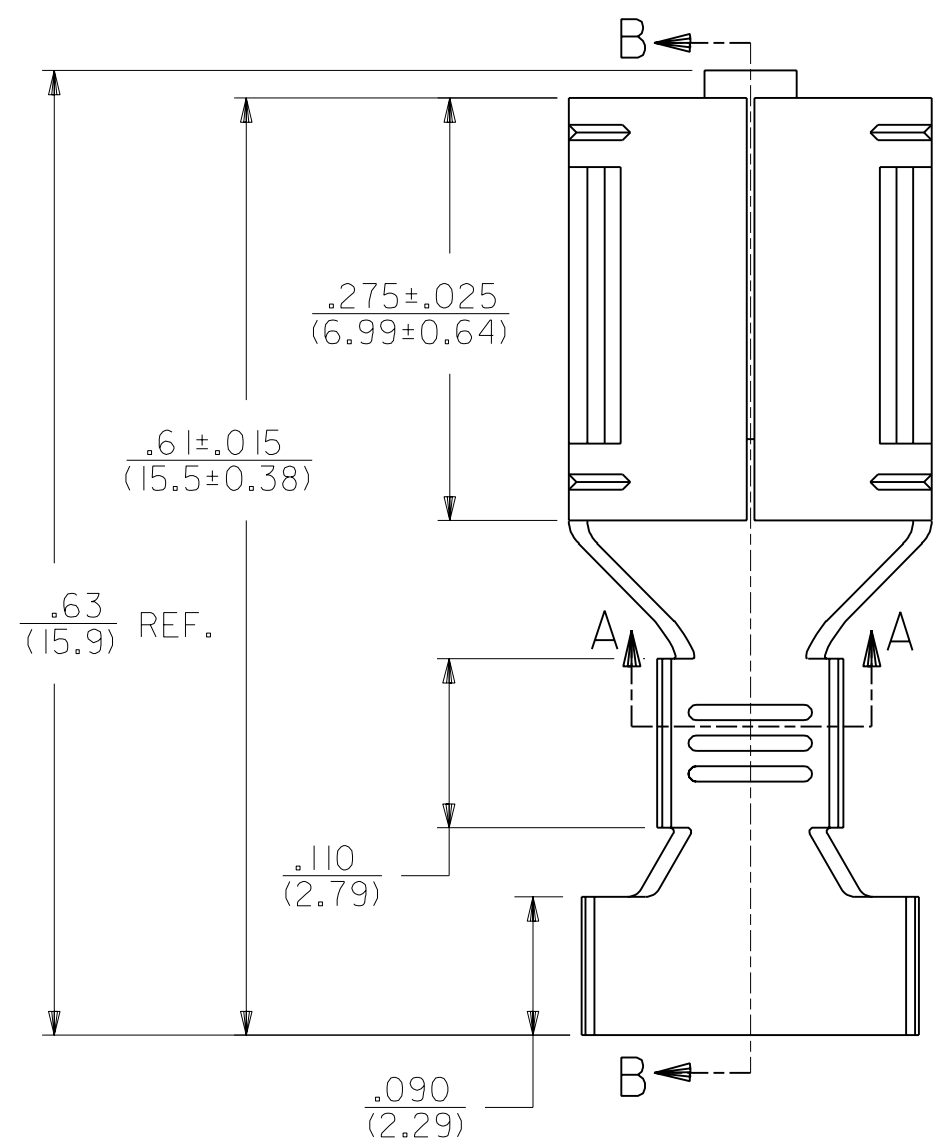
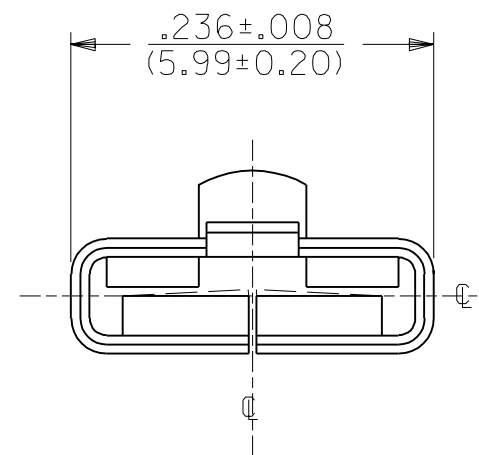

DETENT LOCATION
SCALE 8:1

NOTES:

1. CRIMP FOR #14 THRU #22 GA. WIRE. ALSO (2) #18 GA. WIRE WITH .03(0.79) THK. INSULATION.
2. MATERIAL: .010/(0.25) THK. 70/30 BRASS ALLOY. PRE-TIN PLATED.
3. PRODUCT SPECIFICATION 05-06-1 APPLIES.

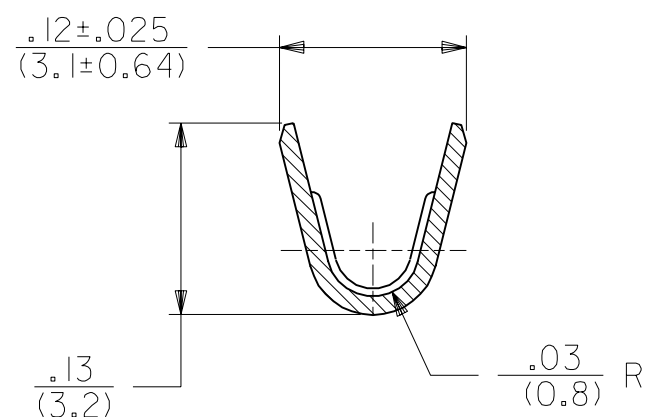
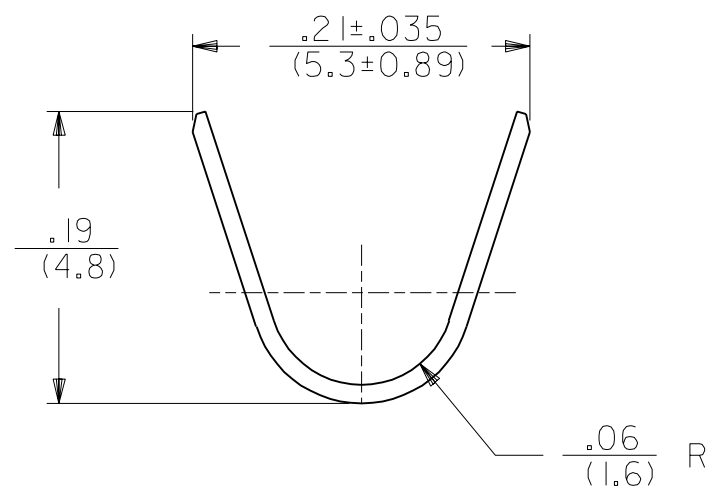

SECTION A-A
SCALE 8:1

MFG.	SH.	REV.	LTR.	REVISIONS
E				REDRAWN ON CAD PER UCR2000-0804 00/07/13 ES

DIMENSIONS SHOWN (METRIC) INCH	
UNLESS OTHERWISE SPECIFIED TOLERANCES: ANGULAR ± 1/2°	
3 PLACE	± .010 ---
2 PLACE	± .014 ± 0.25
1 PLACE	--- ± 0.35

▽ = 0 ▼ = 0 REVISE ONLY ON CAD SYSTEM

TITLE: TERMINAL FOR .020/(0.51) X .187/(4.75) SPADE

MOLEX INCORPORATED SHEET NO. DATE LISLE, ILL. 60532 U.S.A. 1 OF 1 92/10/26

DRWG. BY: MAB CHK'D. BY: KBP APP'D. BY: RAS SCALE: 8:1

SEE CHART SD-2176-*

THIS DRAWING CONTAINS INFORMATION THAT IS PROPRIETARY TO MOLEX INC. AND SHOULD NOT BE USED WITHOUT WRITTEN PERMISSION. DIV. CP C