

CKT SIZE	DIMENSION A		DIMENSION B		DIMENSION C	
	MM	IN	MM	IN	MM	IN
3	8.13	.320	5.08	.200	0.15	.006
4	10.67	.420	7.62	.300	0.15	.006
5	13.21	.520	10.16	.400	0.15	.006
6	15.75	.620	12.70	.500	0.15	.006
7	18.29	.720	15.24	.600	0.15	.006
8	20.83	.820	17.78	.700	0.15	.006
9	23.37	.920	20.32	.800	0.15	.006
10	25.91	1.020	22.86	.900	0.15	.006
11	28.45	1.120	25.40	1.000	0.15	.006
12	30.99	1.220	27.94	1.100	0.15	.006
22	56.39	2.220	53.34	2.099	0.18	.007

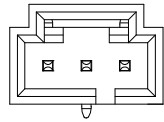

3 CIRCUIT

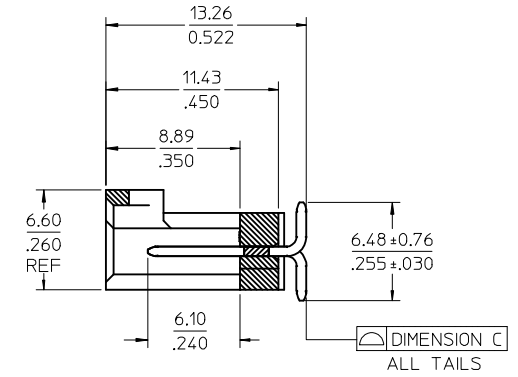
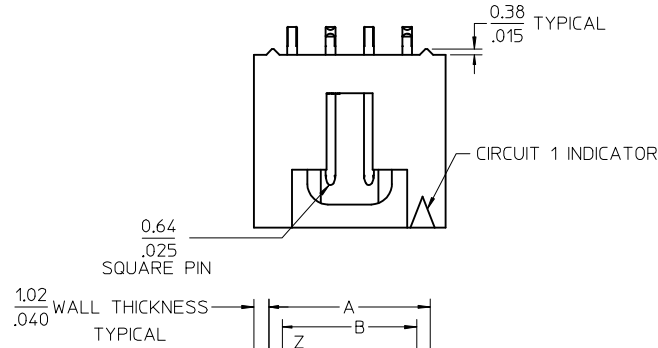

SECTION Z-Z

4 CIRCUIT SHOWN

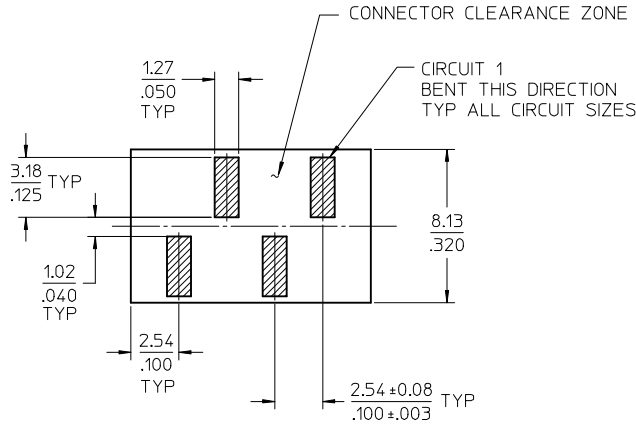

PCB LAYOUT: COMPONENT SIDE
RECOMMENDED PCB THICKNESS: NA

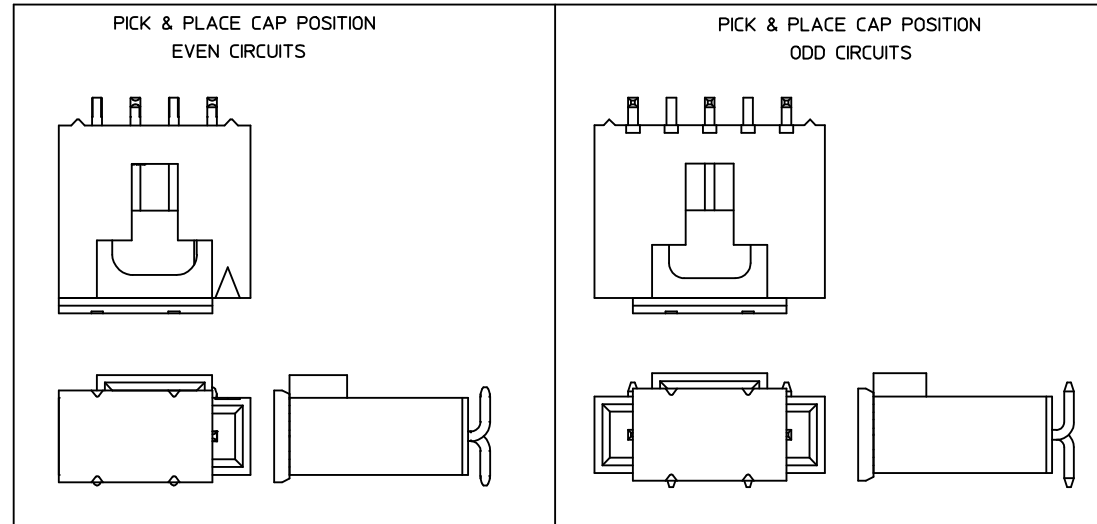

NOTES:

- MATERIAL:
HOUSING: POLYESTER (PCT), GLASS FILLED, UL94V-0; COLOR: BLACK
PINS: PHOSPHOR BRONZE
PICK & PLACE CAP: LIQUID CRYSTAL POLYMER (LCP), GLASS FILLED, UL94V-0, COLOR: BLACK
- FINISH:
TIN - 3.81 MICROMETERS/150 MICROINCHES MINIMUM TIN PLATE OVER NICKEL UNDERPLATE OVERALL.
15 GOLD - 0.38 MICROMETERS/15 MICROINCHES MINIMUM GOLD PLATE IN SELECT AREA, 1.91 MICROMETERS/75 MICROINCHES MINIMUM TIN PLATE IN SELECT AREA, OVER NICKEL UNDERPLATE OVERALL.
30 GOLD - 0.76 MICROMETERS/30 MICROINCHES MINIMUM GOLD PLATE IN SELECT AREA, 1.91 MICROMETERS/75 MICROINCHES MINIMUM TIN PLATE IN SELECT AREA, OVER NICKEL UNDERPLATE OVERALL.
- PRODUCT SPECIFICATION: PS-70541
- PACKAGING SPECIFICATION: PK-70873-9000
- MATES WITH: OPTION 'G' 70400 AND 70430 SERIES SL CONNECTORS
OPTION 'G' 70066 SL HOUSINGS WITH 70058/71851 CRIMP TERMINALS.
- THIS PRODUCT CONFORMS TO COSMETIC SPECIFICATION PS-45499-002 CLASS C.

ADD KEEP OUT ZONE EC NO: UCP2017-1464 DRWN:KSM/IEC 2017/01/04 CHKD: APPR:FSM/ITH 2017/01/04	QUALITY SYMBOLS ▽=0 ▽=0 ▽=0	GENERAL TOLERANCES (UNLESS SPECIFIED)		DIMENSION STYLE MM/IN		SCALE 5:1	DESIGN UNITS INCH	THIRD ANGLE PROJECTION
		mm	INCH	DRAWN BY TIBARRA	DATE 2013/07/11	SALES ASSY, SL VERTICAL HEADER, SMT W/LATCH WITH PICK-N-PLACE CAP molex		
		4 PLACES ± ---	± ---	CHECKED BY DMORGAN	DATE 2013/07/11			
		3 PLACES ± 0.25	± .010	APPROVED BY SMILLER	DATE 2013/08/12			
2 PLACES ± ---	± ---	MATERIAL NO. SEE TABLE	DOCUMENT NO. SD-74099-1000	SHEET NO. 1 OF 2				
DRAFT WHERE APPLICABLE MUST REMAIN WITHIN DIMENSIONS		ANGULAR ±1/2°		SIZE C		THIS DRAWING CONTAINS INFORMATION THAT IS PROPRIETARY TO MOLEX INCORPORATED AND SHOULD NOT BE USED WITHOUT WRITTEN PERMISSION		

	13	12	11	10	9	8	7	6	5	4	3	2	1
J	CIRCUIT SIZE	ASSEMBLY ITEM NUMBER 74099-	PLATING SEE NOTE 2	MATING END PLATING TYPE	PC BOARD END PLATING TYPE								
	3-12, 22	-0603 THRU-0612, -0622	TIN	TIN	TIN								
I	3-12, 22	-0623 THRU-0632, -0642	15 GOLD	GOLD	TIN								
	3-12, 22	-0643 THRU-0652, -0662	30 GOLD	GOLD	TIN								

H													
---	--	--	--	--	--	--	--	--	--	--	--	--	--

CIRCUIT SIZE	ASSEMBLY ITEM NUMBER	ASSEMBLY ITEM NUMBER	ASSEMBLY ITEM NUMBER	ASSEMBLY ITEM NUMBER	ASSEMBLY ITEM NUMBER
3	74099-0603	74099-0623	74099-0643		
4	74099-0604	74099-0624	74099-0644		
5	74099-0605	74099-0625	74099-0645		
6	74099-0606	74099-0626	74099-0646		
7	74099-0607	74099-0627	74099-0647		
8	74099-0608	74099-0628	74099-0648		
9	74099-0609	74099-0629	74099-0649		
10	74099-0610	74099-0630	74099-0650		
11	74099-0611	74099-0631	74099-0651		
12	74099-0612	74099-0632	74099-0652		
22	74099-0622	74099-0642	74099-0662		

D													
---	--	--	--	--	--	--	--	--	--	--	--	--	--

B	SEE SHEET 1 EC NO: UCP2017-1464 DRAWN: KSM/IEC 2017/01/04 CHKD: APPR: FSM/ITH 2017/01/04	DESCRIPTION	QUALITY SYMBOLS	GENERAL TOLERANCES (UNLESS SPECIFIED)			DIMENSION STYLE MM/IN		SCALE 4:1	DESIGN UNITS INCH	THIRD ANGLE PROJECTION		
				mm		INCH		DRAWN BY TIBARRA	DATE 2013/07/11	TITLE SALES ASSY, SL VERTICAL HEADER, SMT W/LATCH WITH PICK-N-PLACE CAP molex			
A	E2	REV	=0	4 PLACES	± .010	± .010	CHECKED BY DMORGAN	DATE 2013/07/11	DOCUMENT NO. SD-74099-1000				
				3 PLACES	± .025	± .010	APPROVED BY SMILLER	DATE 2013/08/12					
				ANGULAR ±1/2°			SEE TABLE		THIS DRAWING CONTAINS INFORMATION THAT IS PROPRIETARY TO MOLEX INCORPORATED AND SHOULD NOT BE USED WITHOUT WRITTEN PERMISSION				
				DRAFT WHERE APPLICABLE MUST REMAIN WITHIN DIMENSIONS			SIZE C						

CKT SIZE	DIMENSION A		DIMENSION B		DIMENSION C	
	MM	IN	MM	IN	MM	IN
3	8.13	.320	5.08	.200	0.15	.006
4	10.67	.420	7.62	.300	0.15	.006
5	13.21	.520	10.16	.400	0.15	.006
6	15.75	.620	12.70	.500	0.15	.006
7	18.29	.720	15.24	.600	0.15	.006
8	20.83	.820	17.78	.700	0.15	.006
9	23.37	.920	20.32	.800	0.15	.006
10	25.91	1.020	22.86	.900	0.15	.006
11	28.45	1.120	25.40	1.000	0.15	.006
12	30.99	1.220	27.94	1.100	0.15	.006
22	56.39	2.220	53.34	2.099	0.18	.007

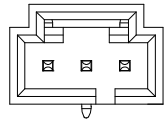

3 CIRCUIT

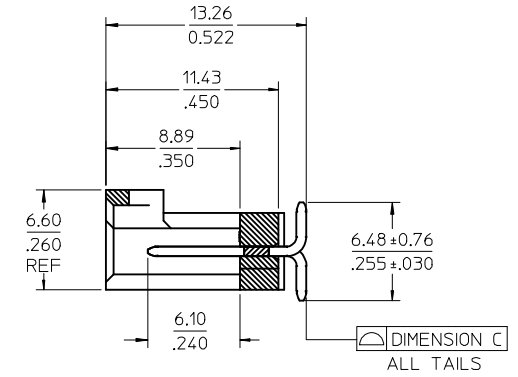
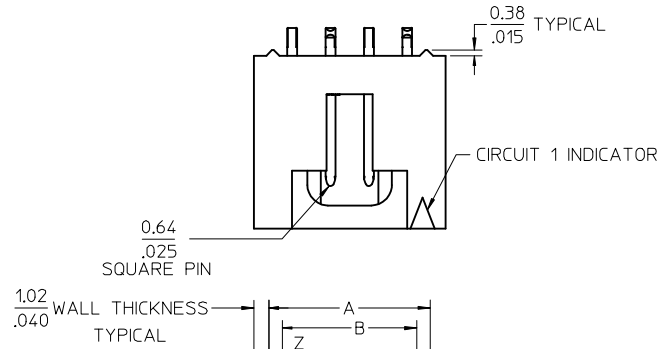

SECTION Z-Z

4 CIRCUIT SHOWN

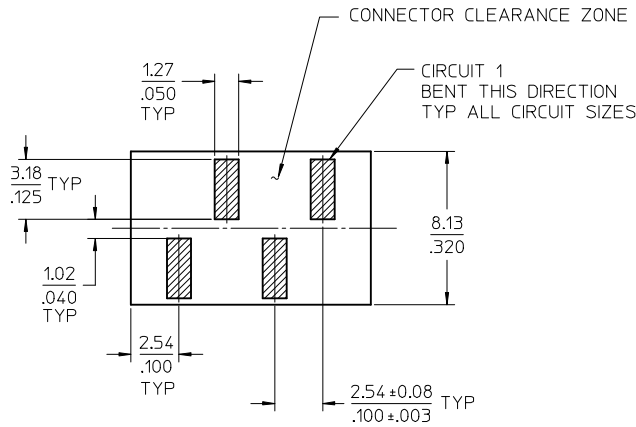

PCB LAYOUT: COMPONENT SIDE
RECOMMENDED PCB THICKNESS: NA

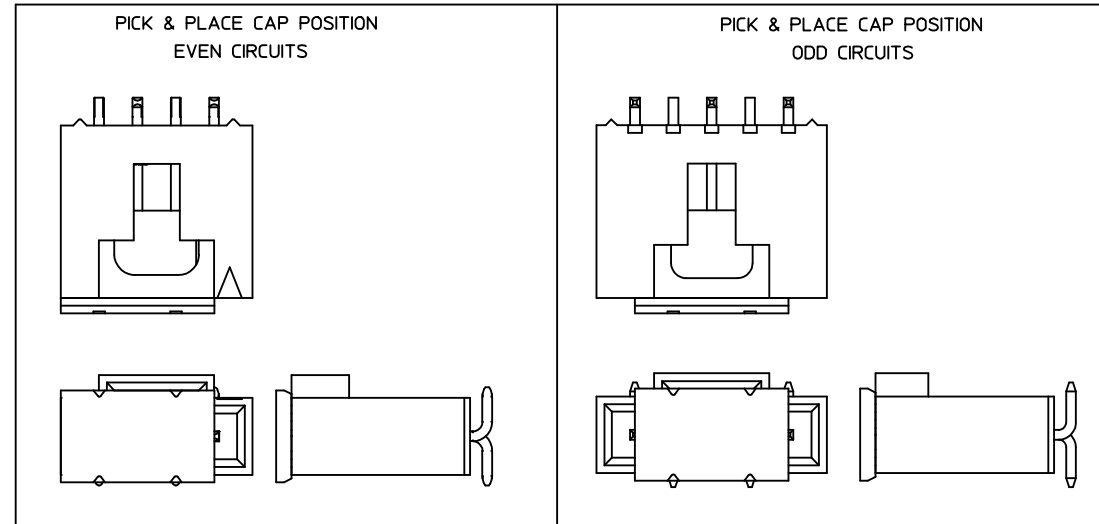

NOTES:

- MATERIAL:
HOUSING: POLYESTER (PCT), GLASS FILLED, UL94V-0; COLOR: BLACK
PINS: PHOSPHOR BRONZE
PICK & PLACE CAP: LIQUID CRYSTAL POLYMER (LCP), GLASS FILLED, UL94V-0, COLOR: BLACK
- FINISH:
TIN - 3.81 MICROMETERS/150 MICROINCHES MINIMUM TIN PLATE OVER NICKEL UNDERPLATE OVERALL.
15 GOLD - 0.38 MICROMETERS/15 MICROINCHES MINIMUM GOLD PLATE IN SELECT AREA, 1.91 MICROMETERS/75 MICROINCHES MINIMUM TIN PLATE IN SELECT AREA, OVER NICKEL UNDERPLATE OVERALL.
30 GOLD - 0.76 MICROMETERS/30 MICROINCHES MINIMUM GOLD PLATE IN SELECT AREA, 1.91 MICROMETERS/75 MICROINCHES MINIMUM TIN PLATE IN SELECT AREA, OVER NICKEL UNDERPLATE OVERALL.
- PRODUCT SPECIFICATION: PS-70541
- PACKAGING SPECIFICATION: PK-70873-9000
- MATES WITH: OPTION 'G' 70400 AND 70430 SERIES SL CONNECTORS
OPTION 'G' 70066 SL HOUSINGS WITH 70058/71851 CRIMP TERMINALS.
- THIS PRODUCT CONFORMS TO COSMETIC SPECIFICATION PS-45499-002 CLASS C.

ADD KEEP OUT ZONE EC NO: UCP2017-1464 DRWN:KSM/IEC 2017/01/04 CHKD: APPR:FSM/ITH 2017/01/04	QUALITY SYMBOLS ▽=0 ▽=0 ▽=0	GENERAL TOLERANCES (UNLESS SPECIFIED)		DIMENSION STYLE		SCALE	DESIGN UNITS	THIRD ANGLE PROJECTION	
				MM/IN		5:1	INCH		
				mm	INCH	DRAWN BY DATE			SALES ASSY, SL VERTICAL HEADER, SMT W/LATCH WITH PICK-N-PLACE CAP
				4 PLACES ± --- ± ---	± --- ± ---	TIBARRA 2013/07/11			
				CHECKED BY DATE		molex	DOCUMENT NO. SD-74099-1000		
				DMORGAN 2013/07/11					
				APPROVED BY DATE		SHEET NO. 1 OF 2			
				SMILLER 2013/08/12					
		ANGULAR ±1/2°		MATERIAL NO.					
		DRAFT WHERE APPLICABLE MUST REMAIN WITHIN DIMENSIONS		SEE TABLE					
				SIZE C		THIS DRAWING CONTAINS INFORMATION THAT IS PROPRIETARY TO MOLEX INCORPORATED AND SHOULD NOT BE USED WITHOUT WRITTEN PERMISSION			

	13	12	11	10	9	8	7	6	5	4	3	2	1
J	CIRCUIT SIZE	ASSEMBLY ITEM NUMBER 74099-	PLATING SEE NOTE 2	MATING END PLATING TYPE	PC BOARD END PLATING TYPE								
	3-12, 22	-0603 THRU-0612, -0622	TIN	TIN	TIN								
I	3-12, 22	-0623 THRU-0632, -0642	15 GOLD	GOLD	TIN								
	3-12, 22	-0643 THRU-0652, -0662	30 GOLD	GOLD	TIN								

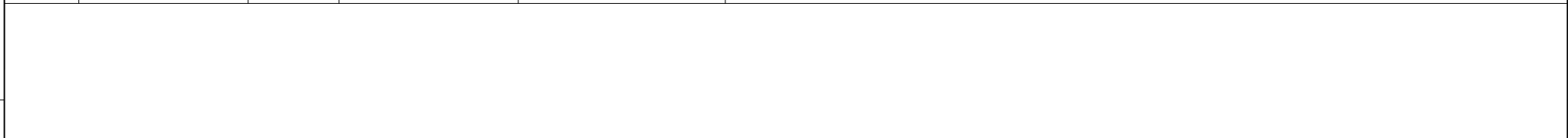

CIRCUIT SIZE	ASSEMBLY ITEM NUMBER	ASSEMBLY ITEM NUMBER	ASSEMBLY ITEM NUMBER	ASSEMBLY ITEM NUMBER	ASSEMBLY ITEM NUMBER
3	74099-0603	74099-0623	74099-0643		
4	74099-0604	74099-0624	74099-0644		
5	74099-0605	74099-0625	74099-0645		
6	74099-0606	74099-0626	74099-0646		
7	74099-0607	74099-0627	74099-0647		
8	74099-0608	74099-0628	74099-0648		
9	74099-0609	74099-0629	74099-0649		
10	74099-0610	74099-0630	74099-0650		
11	74099-0611	74099-0631	74099-0651		
12	74099-0612	74099-0632	74099-0652		
22	74099-0622	74099-0642	74099-0662		

SEE SHEET 1 EC NO: UCP2017-1464 DRWNG:SMIEC 2017/01/04 CHKD: APPR:FSM/ITH 2017/01/04 REVISIONS E2	QUALITY SYMBOLS	GENERAL TOLERANCES (UNLESS SPECIFIED)	DIMENSION STYLE MM/IN		SCALE 4:1	DESIGN UNITS INCH	THIRD ANGLE PROJECTION
	▽=0	▽=0	▽=0	DRAWN BY TIBARRA	DATE 2013/07/11	TITLE SALES ASSY, SL VERTICAL HEADER, SMT W/LATCH WITH PICK-N-PLACE CAP 	
	▽=0	▽=0	▽=0	CHECKED BY DMORGAN	DATE 2013/07/11		
	▽=0	▽=0	▽=0	APPROVED BY SMILLER	DATE 2013/08/12		
ANGULAR ±1/2°		MATERIAL NO.		DOCUMENT NO.			
DRAFT WHERE APPLICABLE MUST REMAIN WITHIN DIMENSIONS			SEE TABLE		SD-74099-1000		SHEET NO. 2 OF 2
THIS DRAWING CONTAINS INFORMATION THAT IS PROPRIETARY TO MOLEX INCORPORATED AND SHOULD NOT BE USED WITHOUT WRITTEN PERMISSION							