

3.3V CMOS Compatible 3.2 x 2.5mm SMD Crystal Oscillator

ASE Series

Request Samples



Check Inventory



ESD Sensitive



3.2 x 2.5 x 1.2 mm
RoHS/RoHS II Compliant
MSL Level = 1

Features

- Low height 1.2mm max
- Tri-state function
- Low current consumption
- 30mA max for 200MHz
- Low RMS jitter 5ps max
- Suitable for RoHS reflow
- Available for tight stability option

Applications

- CCD clock for VTR camera
- Equipment connected to PC or PC cards
- PDA, wireless communication
- Laptop, SSD (Solid State Drive)

Key Electrical Specifications

Parameters	Minimum	Typical	Maximum	Units	Notes
Frequency Range	0.625		200	MHz	
Operating Temperature	-10		+70	°C	STD (See options)
Storage Temperature	-55		+125	°C	
Overall Frequency Stability	-100		+100	ppm	See options
Supply Voltage (Vdd)	+3.135	3.3	+3.465	V	
Supply Current (Idd)		2.5	7	mA	0.5 ~ 20 MHz
		4.4	13		20.1 ~ 40.0 MHz
		6.5	19		40.01 ~ 60.0 MHz
		12.7	24		60.01 ~ 75.0 MHz
		7.4	20		75.01 ~ 80.0 MHz
		7.4	25		80.01 ~ 133.0MHz
		11.7	30		133.01 ~ 200.0 MHz
Symmetry @ 1/2Vdd	45	50	55	%	0.5 ~ 80.0MHz
	40	50	60		80.01 ~ 200.0MHz
Rise and Fall Time (Tr/Tf)		2.5	4.0	ns	0.5 ~ 20 MHz
		2.4	4.0		20.1 ~ 40.0 MHz
		2.4	4.0		40.01 ~ 60.0 MHz
		2.3	4.0		60.01 ~ 75.0 MHz
		1.5	4.0		75.01 ~ 133.0 MHz
		1.9	4.0		133.01 ~ 200.0 MHz
Output Load			15	pF	CMOS
Output Voltage (VOH)	0.9* Vdd			V	
Output Voltage (VOL)			0.1* Vdd	V	
Start-up Time		1	2.0	ms	0.5 ~ 20 MHz
		1	2.0		20.1 ~ 40.0 MHz
		1	2.0		40.01 ~ 60.0 MHz
		1	2.0		60.01 ~ 75.0 MHz
		1.2	2.0		75.01 ~ 133.0 MHz
		1.5	2.0		133.01 ~ 200.0 MHz



5101 Hidden Creek Ln Spicewood TX 78669
Phone: 512-371-6159 | Fax: 512-351-8858
For terms and conditions of sales, please visit:
www.abracon.com

REVISED: 02-18-22

ABRACON IS
ISO9001-2015
CERTIFIED

3.3V CMOS Compatible 3.2 x 2.5mm SMD Crystal Oscillator

ASE Series

Request Samples



Check Inventory



ESD Sensitive



3.2 x 2.5 x 1.2 mm
 RoHS/RoHS II Compliant
 MSL Level = 1

Parameters	Minimum	Typical	Maximum	Units	Notes
Tri-state function (Stand-by)	"1" ($V_{IH} \geq 0.7 \cdot V_{DD}$) or Open: Oscillation; "0" ($V_{IL} < 0.3 \cdot V_{DD}$): No oscillation/Hi Z				
Peak to Peak Jitter		28		ps	Reference only. Contact ABRACON for the Jitter
RMS Jitter:		3.2	5	ps	0.5 ~ 20 MHz
		3.2	5		20.1 ~ 40.0 MHz
		3.2	5		40.01 ~ 60.0 MHz
		3.2	5		60.01 ~ 75.0 MHz
		2.2	5		75.01 ~ 133.0 MHz
		2.2	5		133.01 ~ 200.0 MHz
Aging at 25°C (first year)	-3		+3	ppm	
Stand-by Current:			10	µA	



5101 Hidden Creek Ln Spicewood TX 78669
 Phone: 512-371-6159 | Fax: 512-351-8858
 For terms and conditions of sales, please visit:
www.abracon.com

REVISED: 02-18-22

ABRACON IS
 ISO9001-2015
 CERTIFIED

3.3V CMOS Compatible 3.2 x 2.5mm SMD Crystal Oscillator

ASE Series

Request Samples



Check Inventory



ESD Sensitive



3.2 x 2.5 x 1.2 mm
RoHS/RoHS II Compliant
MSL Level = 1

Options and Part Identification (Left blank if standard)

ASE - MHz - - -

Frequency in MHz
e.g. 0.625MHz
24.576MHz
14.31818MHz
26.000MHz
200.000MHz

Operating Temp.
I: 0°C ~ +50°C
D: -10°C ~ +60°C
E: -20°C ~ +70°C
F: -30°C ~ +70°C
N: -30°C ~ +85°C
L: -40°C ~ +85°C

Contact ABRACON for wider temperature range.

Overall Freq. Stability
J(*): ±20ppm
R: ±25ppm
K: ±30ppm
H: ±35ppm
B: ±40ppm
C: ±50ppm

*: Temp options I, D, E, and -10°C to +70°C only

Packaging
Blank: Bulk
T: 1000pcs/Reel
T2: 250pcs/Reel
T3: 3000pcs/Reel



5101 Hidden Creek Ln Spicewood TX 78669
Phone: 512-371-6159 | Fax: 512-351-8858
For terms and conditions of sales, please visit:
www.abracon.com

REVISED: 02-18-22

ABRACON IS
ISO9001-2015
CERTIFIED

3.3V CMOS Compatible 3.2 x 2.5mm SMD Crystal Oscillator

ASE Series

Request Samples



Check Inventory



ESD Sensitive



3.2 x 2.5 x 1.2 mm
RoHS/RoHS II Compliant
MSL Level = 1

Reflow Profile [JEDEC J-STD-020]

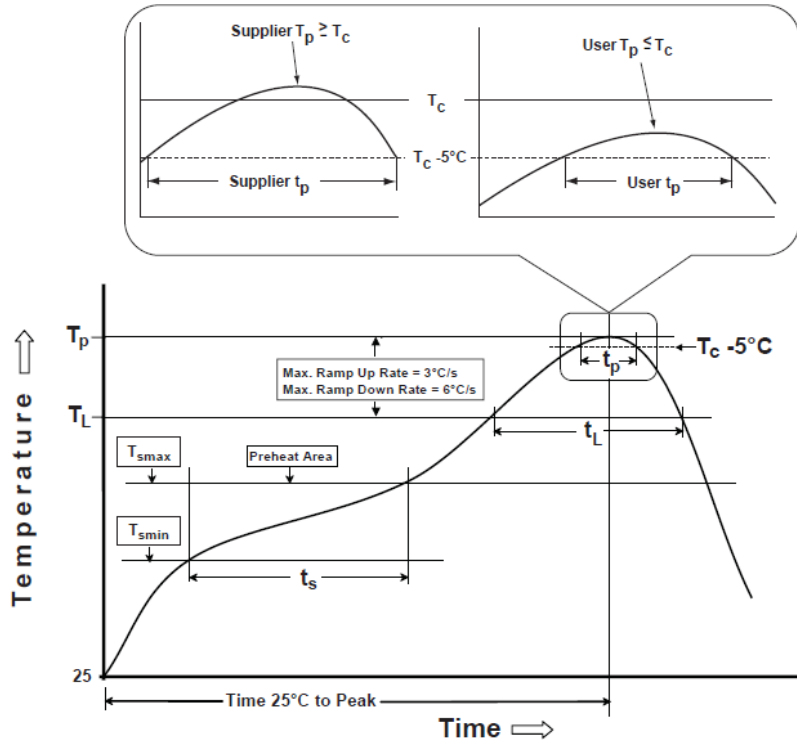

Table 1

SnPb Eutectic Process
Classification Temperatures (T_c)

Package Thickness	Volume mm ³ <350	Volume mm ³ ≥350
<2.5 mm	235 °C	220 °C
≥2.5 mm	220 °C	220 °C

Table 2

Pb-Free Process
Classification Temperatures (T_c)

Package Thickness	Volume mm ³ <350	Volume mm ³ 350-2000	Volume mm ³ >2000
<1.6 mm	260 °C	260 °C	260 °C
1.6 mm - 2.5 mm	260 °C	250 °C	245 °C
>2.5 mm	250 °C	245 °C	245 °C

Profile Feature	Sn-Pb Eutectic Assembly	Pb-Free Assembly
Preheat / soak		
Temperature minimum (T_{smin})	100°C	150°C
Temperature maximum (T_{smax})	150°C	200°C
Time (T_{smin} to T_{smax}) (t_s)	60 - 120 sec.	60 - 120 sec.
Average ramp-up rate (T_{smax} to T_p)	3°C/sec. max	3°C/sec. max
Liquidous temperature (T_L)	183°C	217°C
Time at liquidous (t_L)	60 - 150 sec.	60 - 150 sec.
Peak package body temperature (T_p)*	see Table 1	see Table 2
Time (t_p)** within 5°C of the specified classification temperature (T_c)	20 sec.	30 sec.
Ramp-down rate (T_p to T_{smax})	6°C/sec. max	6°C/sec. max
Time 25°C to peak temperature	6 min. max	8 min. max
Reflow cycles	2 max	2 max

*Tolerance for peak profile temperature (T_p) is defined as a supplier minimum and a user maximum.

**Tolerance for time at peak profile temperature (t_p) is defined as supplier minimum and a user maximum.

3.3V CMOS Compatible 3.2 x 2.5mm SMD Crystal Oscillator

ASE Series

Request Samples



Check Inventory



ESD Sensitive



3.2 x 2.5 x 1.2 mm
 RoHS/RoHS II Compliant
 MSL Level = 1

Mechanical Dimensions

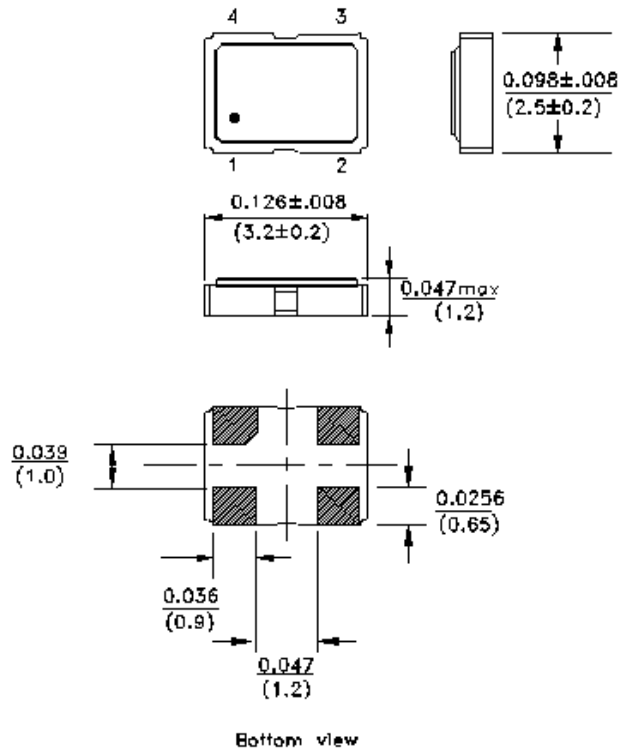

Recommended land pattern

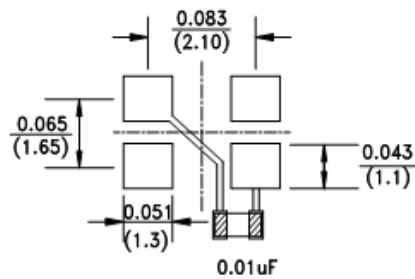

Pin	Function
1	Tri-State (STBY)
2	GND/Case
3	Output
4	Vdd

Dimensions: inches (mm)

Note1: Recommend using an approximately 0.01µF bypass capacitor between PIN 2 and 4.

Note2: The outline package configuration varies with frequency range. Electrical properties, pin configuration, and land pattern are the same.

3.3V CMOS Compatible 3.2 x 2.5mm SMD Crystal Oscillator

ASE Series

Request Samples



Check Inventory



ESD Sensitive



3.2 x 2.5 x 1.2 mm
RoHS/RoHS II Compliant
MSL Level = 1

Packaging

T: 1000 pcs/reel
T2: 250 pcs/reel
T3: 3000 pcs/reel

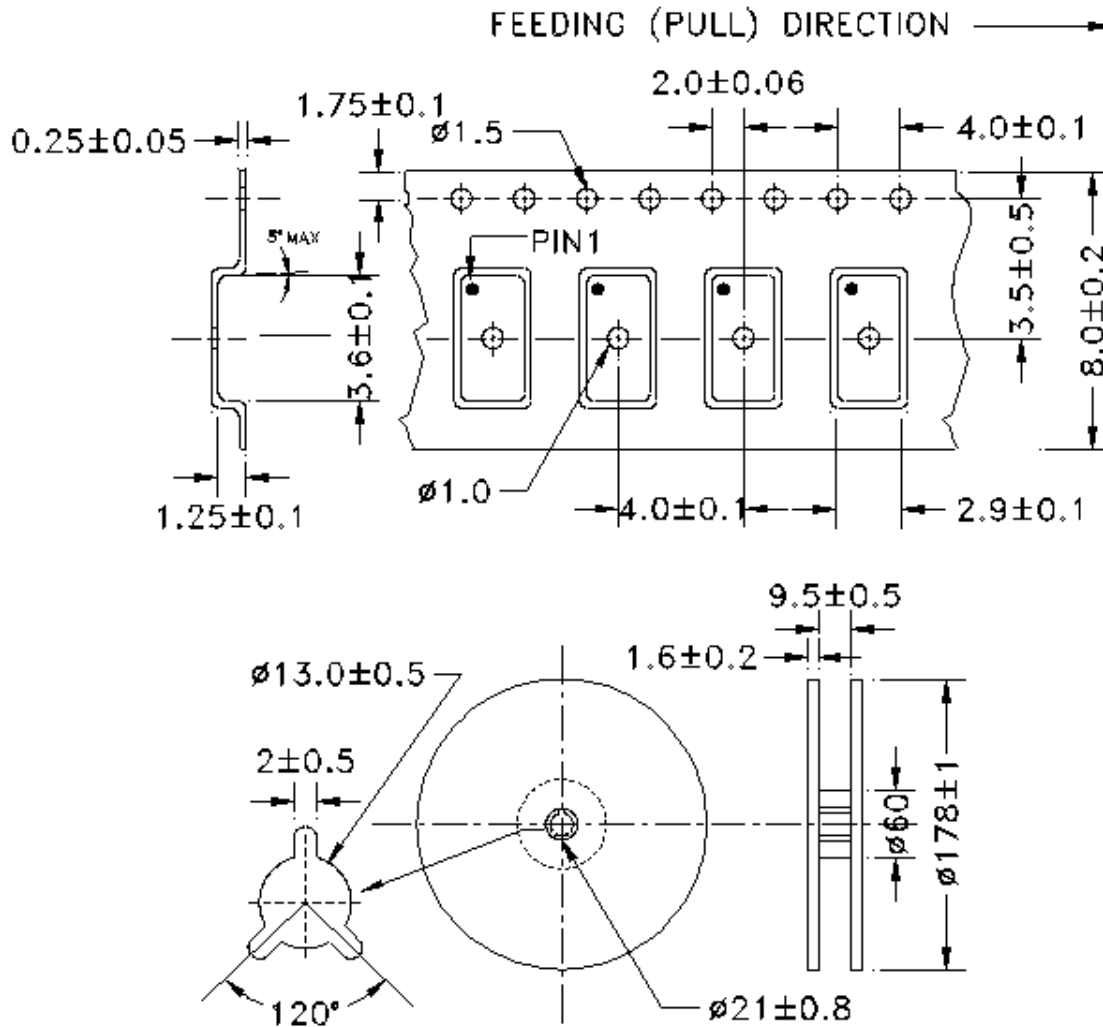

Dimensions: mm

ATTENTION: Abracon LLC's products are COTS – Commercial-Off-The-Shelf products; suitable for Commercial, Industrial and, where designated, Automotive Applications. Abracon's products are not specifically designed for Military, Aviation, Aerospace, Life-dependent Medical applications or any application requiring high reliability where component failure could result in loss of life and/or property. For applications requiring high reliability and/or presenting an extreme operating environment, written consent and authorization from Abracon LLC is required. Please contact Abracon LLC for more information.



5101 Hidden Creek Ln Spicewood TX 78669
Phone: 512-371-6159 | Fax: 512-351-8858
For terms and conditions of sales, please visit:
www.abracon.com

REVISED: 02-18-22

ABRACON IS
ISO9001-2015
CERTIFIED