



# QUICKSWITCH® PRODUCTS

## 2.5V/3.3V QUAD 2:1 MUX/DEMUX

### HIGH BANDWIDTH BUS SWITCH

IDTQS3VH257

### FEATURES:

- N channel FET switches with no parasitic diode to Vcc
  - Isolation under power-off conditions
  - No DC path to Vcc or GND
  - 5V tolerant in OFF and ON state
- 5V tolerant I/Os
- Low RON - 4Ω typical
- Flat RON characteristics over operating range
- Rail-to-rail switching 0 - 5V
- Bidirectional dataflow with near-zero delay: no added ground bounce
- Excellent RON matching between channels
- VCC operation: 2.3V to 3.6V
- High bandwidth - up to 500MHz
- LVTTTL-compatible control Inputs
- Undershoot Clamp Diodes on all switch and control Inputs
- Low I/O capacitance, 4pF typical
- Available in QSOP, SOIC, and TSSOP packages

### APPLICATIONS:

- Hot-swapping
- Multiplexing/demultiplexing
- Low distortion analog switch
- Replaces mechanical relay
- ATM 25/155 switching

### DESCRIPTION:

The QS3VH257 HotSwitch Quad 2:1 multiplexer/demultiplexer is a high bandwidth bus switch. The QS3VH257 has very low ON resistance, resulting in under 250ps propagation delay through the switch. The Select (S) input controls the data flow. The multiplexers/demultiplexers are enabled when the Enable ( $\bar{E}$ ) input is low. In the ON state, the switches can pass signals up to 5V. In the OFF state, the switches offer very high impedance at the terminals.

The combination of near-zero propagation delay, high OFF impedance, and over-voltage tolerance makes the QS3VH257 ideal for high performance communication applications.

The QS3VH257 is characterized for operation from -40°C to +85°C.

### FUNCTIONAL BLOCK DIAGRAM

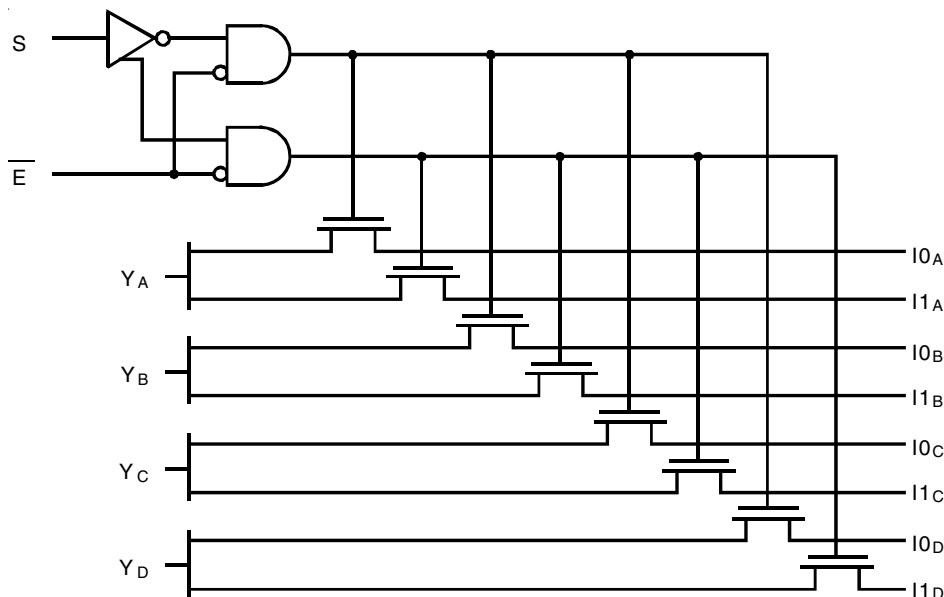

The IDT logo is a registered trademark of Integrated Device Technology, Inc.

**INDUSTRIAL TEMPERATURE RANGE**

**FEBRUARY 2014**

## PIN CONFIGURATION

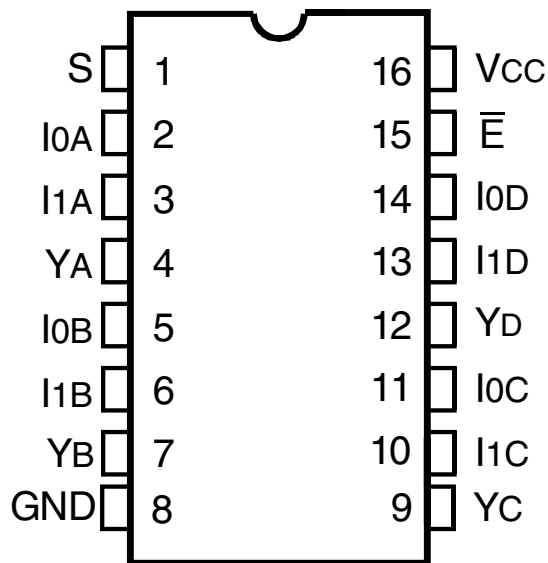

QSOP/ SOIC/ TSSOP  
TOP VIEW

## ABSOLUTE MAXIMUM RATINGS(1)

Symbol	Description	Max	Unit
VTERM <sup>(2)</sup>	Supply Voltage to Ground	-0.5 to +4.6	V
VTERM <sup>(3)</sup>	DC Switch Voltage Vs	-0.5 to +5.5	V
VTERM <sup>(3)</sup>	DC Input Voltage VIN	-0.5 to +5.5	V
VAC	AC Input Voltage (pulse width ≤20ns)	-3	V
IOUT	DC Output Current (max. sink current/pin)	120	mA
TSTG	Storage Temperature	-65 to +150	°C

### NOTES:

- Stresses greater than those listed under ABSOLUTE MAXIMUM RATINGS may cause permanent damage to the device. This is a stress rating only and functional operation of the device at these or any other conditions above those indicated in the operational sections of this specification is not implied. Exposure to absolute maximum rating conditions for extended periods may affect reliability.
- VCC terminals.
- All terminals except VCC.

## CAPACITANCE (TA = +25°C, F = 1MHz, VIN = 0V, VOUT = 0V)

Symbol	Parameter <sup>(1)</sup>	Typ.	Max.	Unit	
CIN	Control Inputs	3	5	pF	
C <sub>I/O</sub>	Quickswitch Channels (Switch OFF)	Demux	4	6	pF
		Mux	7	9	
C <sub>I/O</sub>	Quickswitch Channels (Switch ON)	Demux	10	15	pF
		Mux	10	15	

### NOTE:

- This parameter is guaranteed but not production tested.

## PIN DESCRIPTION

Pin Names	I/O	Description
Ixx	I	Data Inputs
S	I	Select Input
E-bar	I	Enable Input
YA - YD	O	Data Outputs

## FUNCTION TABLE(1)

Inputs		Outputs				Function
E-bar	S	YA	YB	Yc	YD	
H	X	Z	Z	Z	Z	Disable
L	L	I0A	I0B	I0c	I0D	Select 0
L	H	I1A	I1B	I1c	I1D	Select 1

### NOTE:

- H = HIGH Voltage Level  
L = LOW Voltage Level  
X = Don't Care  
Z = High-Impedence

## DC ELECTRICAL CHARACTERISTICS OVER OPERATING RANGE

Following Conditions Apply Unless Otherwise Specified:

Industrial:  $T_A = -40^{\circ}\text{C}$  to  $+85^{\circ}\text{C}$ ,  $V_{CC} = 3.3\text{V} \pm 0.3\text{V}$

Symbol	Parameter	Test Conditions			Min.	Typ. <sup>(1)</sup>	Max.	Unit
$V_{IH}$	Input HIGH Voltage	Guaranteed Logic HIGH for Control Inputs	$V_{CC} = 2.3\text{V}$ to $2.7\text{V}$		1.7	—	—	V
			$V_{CC} = 2.7\text{V}$ to $3.6\text{V}$		2	—	—	
$V_{IL}$	Input LOW Voltage	Guaranteed Logic LOW for Control Inputs	$V_{CC} = 2.3\text{V}$ to $2.7\text{V}$		—	—	0.7	V
			$V_{CC} = 2.7\text{V}$ to $3.6\text{V}$		—	—	0.8	
$I_{IN}$	Input Leakage Current (Control Inputs)	$0\text{V} \leq V_{IN} \leq V_{CC}$			—	—	$\pm 1$	$\mu\text{A}$
$I_{OZ}$	Off-State Current (Hi-Z)	$0\text{V} \leq V_{OUT} \leq 5\text{V}$ , Switches OFF			—	—	$\pm 1$	$\mu\text{A}$
$I_{OFF}$	Data Input/Output Power Off Leakage	$V_{IN}$ or $V_{OUT}$ $0\text{V}$ to $5\text{V}$ , $V_{CC} = 0\text{V}$			—	—	$\pm 1$	$\mu\text{A}$
$R_{ON}$	Switch ON Resistance	$V_{CC} = 2.3\text{V}$ Typical at $V_{CC} = 2.5\text{V}$	$V_{IN} = 0\text{V}$	$I_{ON} = 30\text{mA}$	—	6	8	$\Omega$
			$V_{IN} = 1.7\text{V}$	$I_{ON} = 15\text{mA}$	—	7	9	
		$V_{CC} = 3\text{V}$	$V_{IN} = 0\text{V}$	$I_{ON} = 30\text{mA}$	—	4	6	
			$V_{IN} = 2.4\text{V}$	$I_{ON} = 15\text{mA}$	—	5	8	

**NOTE:**

1. Typical values are at  $V_{CC} = 3.3\text{V}$  and  $T_A = 25^{\circ}\text{C}$ .

### TYPICAL ON RESISTANCE vs $V_{IN}$ AT $V_{CC} = 3.3\text{V}$

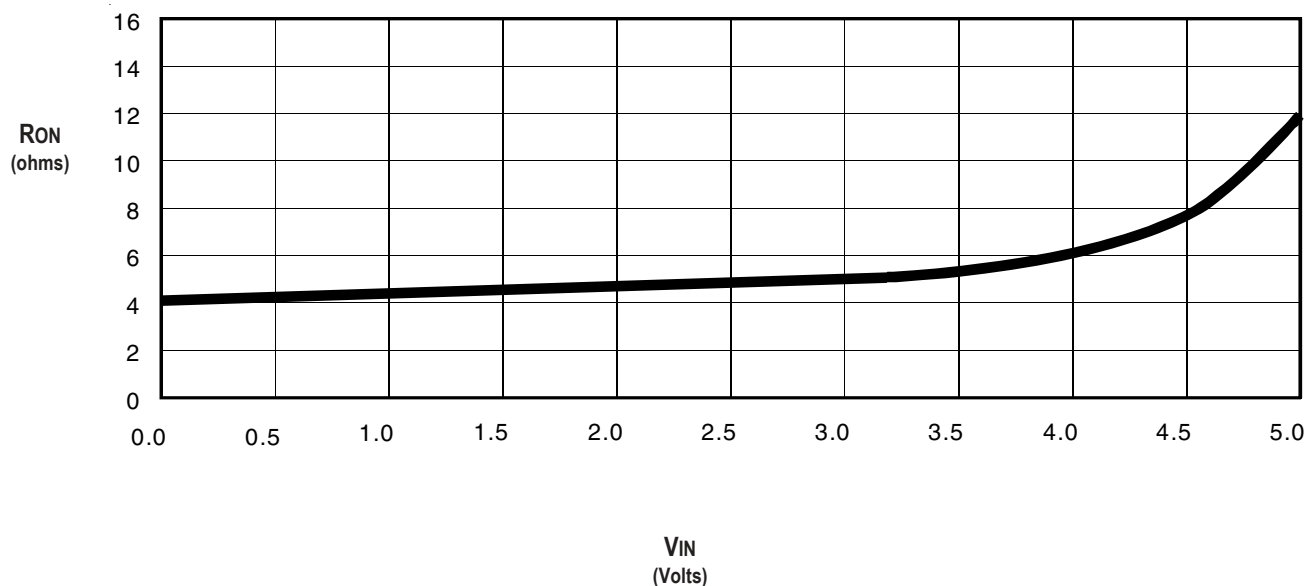

## POWER SUPPLY CHARACTERISTICS

Symbol	Parameter	Test Conditions <sup>(1)</sup>	Min.	Typ.	Max.	Unit
I <sub>CCQ</sub>	Quiescent Power Supply Current	V <sub>CC</sub> = Max., V <sub>IN</sub> = GND or V <sub>CC</sub> , f = 0	—	2	4	mA
ΔI <sub>CC</sub>	Power Supply Current <sup>(2,3)</sup> per Input HIGH	V <sub>CC</sub> = Max., V <sub>IN</sub> = 3V, f = 0 per Control Input	—	—	30	μA
I <sub>CCD</sub>	Dynamic Power Supply Current <sup>(4)</sup>	V <sub>CC</sub> = 3.3V, A and B Pins Open, Control Inputs Toggling @ 50% Duty Cycle	See Typical I <sub>CCD</sub> vs Enable Frequency graph below			

**NOTES:**

1. For conditions shown as Min. or Max., use the appropriate values specified under DC Electrical Characteristics.
2. Per input driven at the specified level. Mux/demux pins do not contribute to ΔI<sub>CC</sub>.
3. This parameter is guaranteed but not tested.
4. This parameter represents the current required to switch internal capacitance at the specified frequency. The mux/demux inputs do not contribute to the Dynamic Power Supply Current. This parameter is guaranteed but not production tested.

### TYPICAL I<sub>CCD</sub> vs ENABLE FREQUENCY CURVE AT V<sub>CC</sub> = 3.3V

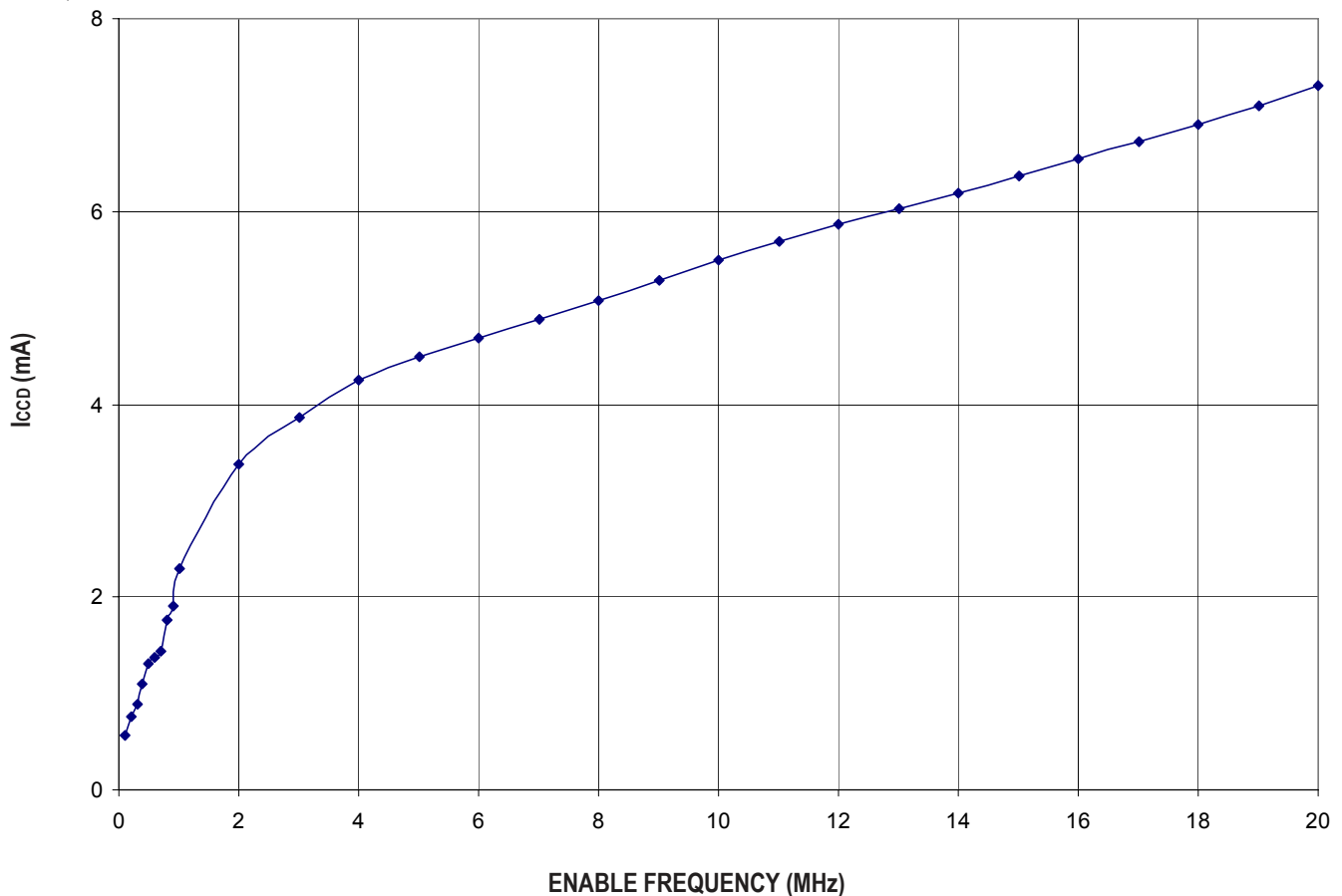

**SWITCHING CHARACTERISTICS OVER OPERATING RANGE**T<sub>A</sub> = -40°C to +85°C

Symbol	Parameter	V <sub>CC</sub> = 2.5 ± 0.2V <sup>(1)</sup>		V <sub>CC</sub> = 3.3 ± 0.3V <sup>(1)</sup>		Unit
		Min. <sup>(4)</sup>	Max.	Min. <sup>(4)</sup>	Max.	
t <sub>PLH</sub>	Data Propagation Delay <sup>(2,3)</sup>	—	0.2	—	0.2	ns
t <sub>PHL</sub>	Y <sub>x</sub> to I <sub>xx</sub> or I <sub>xx</sub> to Y <sub>x</sub>					
t <sub>SEL</sub>	Select Time S to Y <sub>x</sub>	1.5	9	1.5	8	ns
t <sub>PZH</sub>	Enable Time	1.5	9	1.5	9	ns
t <sub>PZL</sub>	S to I <sub>xx</sub>					
t <sub>PHZ</sub>	Disable Time	1.5	8	1.5	8	ns
t <sub>PLZ</sub>	S to I <sub>xx</sub>					
t <sub>PZH</sub>	Enable Time	1.5	9	1.5	8	ns
t <sub>PZL</sub>	$\bar{E}$ to Y <sub>x</sub> or I <sub>xx</sub>					
t <sub>PHZ</sub>	Disable Time	1.5	8	1.5	8	ns
t <sub>PLZ</sub>	$\bar{E}$ to Y <sub>x</sub> or I <sub>xx</sub>					
f <sub>EorS</sub>	Operating Frequency - Enable <sup>(2,5)</sup>	—	10	—	20	MHz

**NOTES:**

1. See Test Conditions under TEST CIRCUITS AND WAVEFORMS.
2. This parameter is guaranteed but not production tested.
3. The bus switch contributes no propagation delay other than the RC delay of the ON resistance of the switch and the load capacitance. The time constant for the switch alone is of the order of 0.2ns at C<sub>L</sub> = 50pF. Since this time constant is much smaller than the rise and fall times of typical driving signals, it adds very little propagation delay to the system. Propagation delay of the bus switch, when used in a system, is determined by the driving circuit on the driving side of the switch and its interaction with the load on the driven side.
4. Minimums are guaranteed but not production tested.
5. Maximum toggle frequency for S or  $\bar{E}$  control input (pass voltage > V<sub>CC</sub>, V<sub>IN</sub> = 5V, R<sub>LOAD</sub> ≥ 1MΩ, no C<sub>LOAD</sub>).

## SOME APPLICATIONS FOR HOTSWITCH PRODUCTS

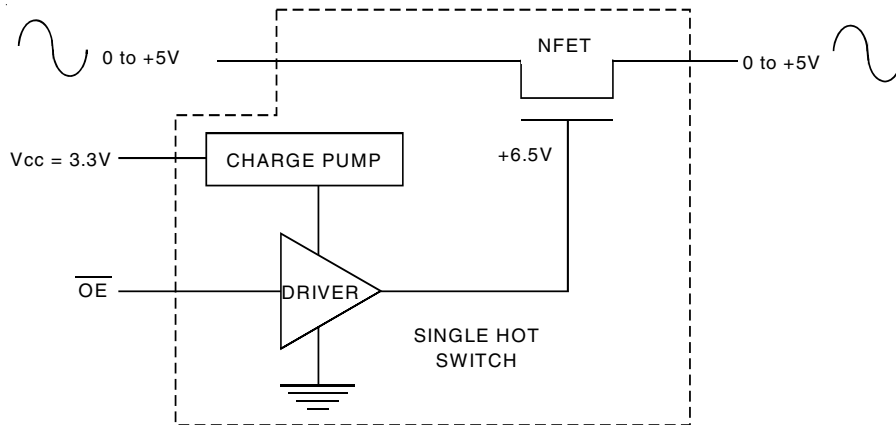

*Rail-to-Rail Switching*

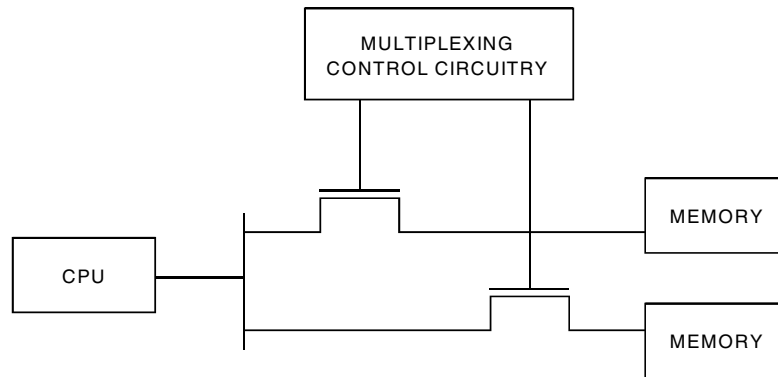

*Multiplexing / Demultiplexing*

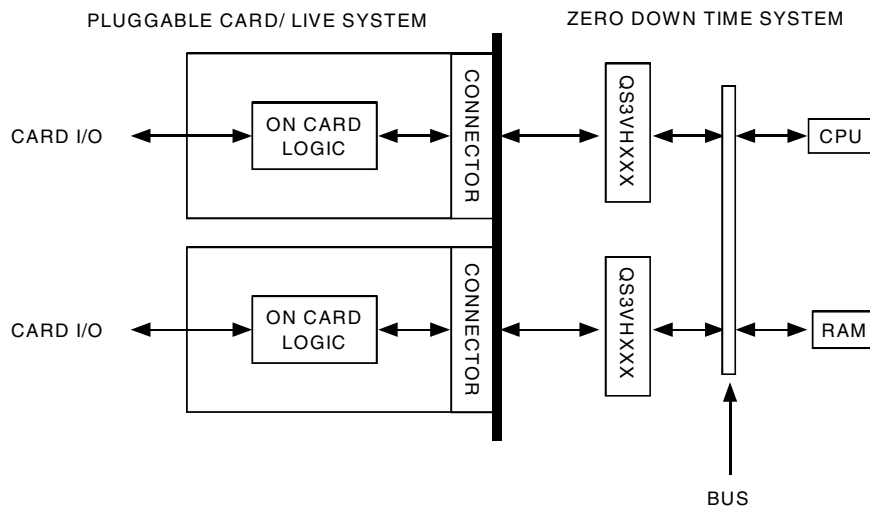

*Hot-Swapping*

## TEST CIRCUITS AND WAVEFORMS

### TEST CONDITIONS

Symbol	Vcc <sup>(1)</sup> = 3.3V ± 0.3V	Vcc <sup>(2)</sup> = 2.5V ± 0.2V	Unit
V <sub>LOAD</sub>	6	2 x V <sub>CC</sub>	V
V <sub>IH</sub>	3	V <sub>CC</sub>	V
V <sub>T</sub>	1.5	V <sub>CC</sub> /2	V
V <sub>LZ</sub>	300	150	mV
V <sub>HZ</sub>	300	150	mV
C <sub>L</sub>	50	30	pF

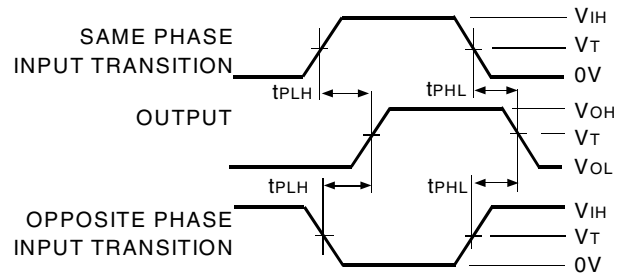

Propagation Delay

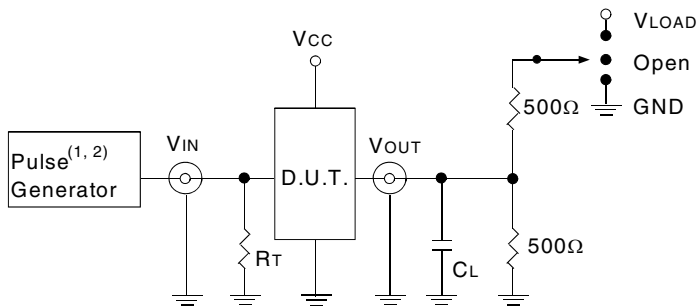

Test Circuits for All Outputs

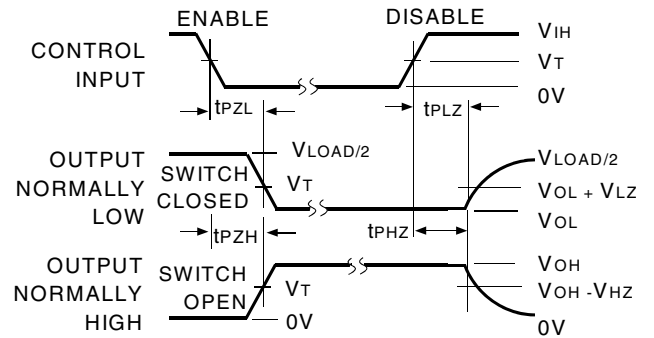

**NOTE:**

1. Diagram shown for input Control Enable-LOW and input Control Disable-HIGH.

### Enable and Disable Times

**DEFINITIONS:**

C<sub>L</sub> = Load capacitance: includes jig and probe capacitance.

R<sub>T</sub> = Termination resistance: should be equal to Z<sub>OUT</sub> of the Pulse Generator.

**NOTES:**

1. Pulse Generator for All Pulses: Rate ≤ 10MHz; t<sub>r</sub> ≤ 2.5ns; t<sub>f</sub> ≤ 2.5ns.
2. Pulse Generator for All Pulses: Rate ≤ 10MHz; t<sub>r</sub> ≤ 2ns; t<sub>f</sub> ≤ 2ns.

### SWITCH POSITION

Test	Switch
t <sub>PLZ</sub> /t <sub>PZL</sub>	V <sub>LOAD</sub>
t <sub>PHZ</sub> /t <sub>PZH</sub>	GND
t <sub>PD</sub>	Open

## ORDERING INFORMATION

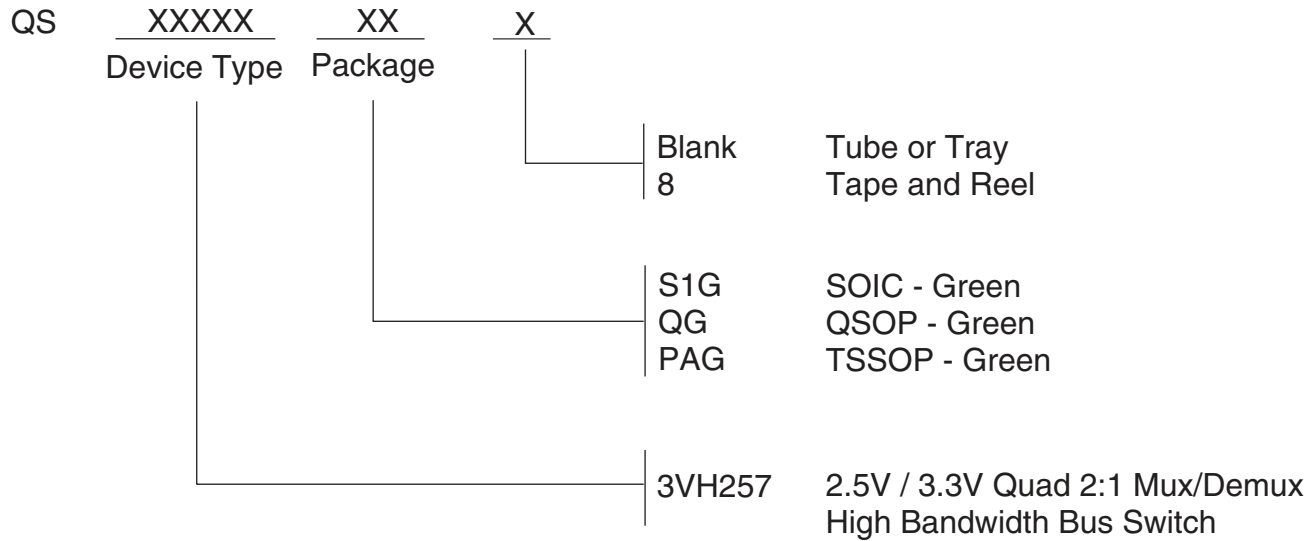

## Datasheet Document History

09/01/08	Pg. 4, 8	Revise lccq Typ. and Max. Remove non green package version and updated the ordering information by removing the "IDT" notation.
02/24/14	Pg. 8	Updated the Ordering Information by Adding Tape and Reel information.



**CORPORATE HEADQUARTERS**  
 6024 Silver Creek Valley Road  
 San Jose, CA 95138

**for SALES:**  
 800-345-7015 or 408-284-8200  
 fax: 408-284-2775  
 www.idt.com

**for Tech Support:**  
 logichelp@idt.com