

DETAIL VIEW
SCALE 8:1

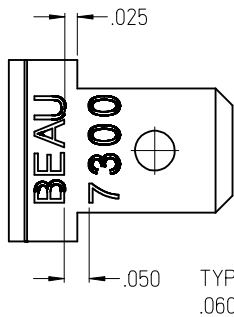
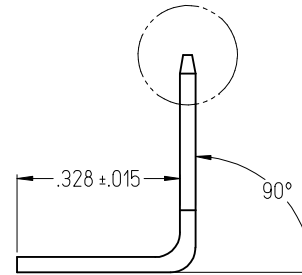
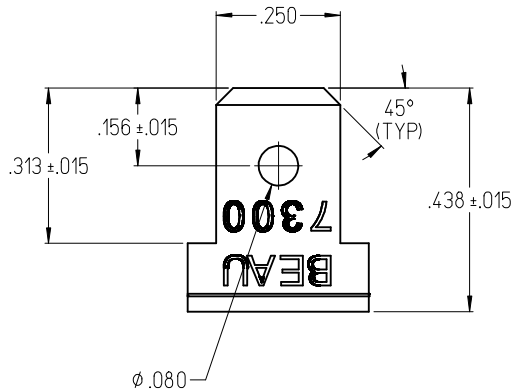
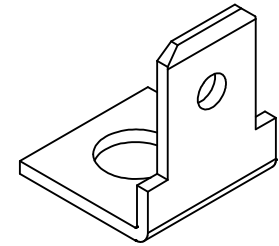
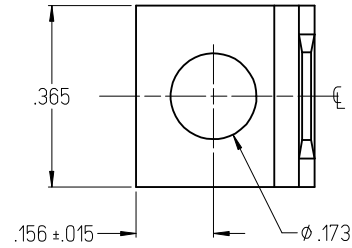
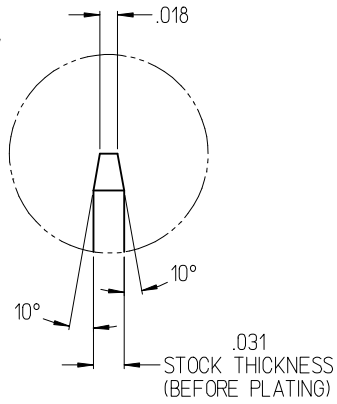

TYPICAL IMPRINT
.060 CHARACTERS

NOTES:
1. PART IS RoHS COMPLIANT

380021348	7315	TERMINAL, .250 FAST TAB, VVR	BRASS	TIN PLATE
MATERIAL NO.	ENGINEERING NO.	DESCRIPTION	MATERIAL	FINISH
GENERAL TOLERANCES (UNLESS SPECIFIED)		DIMENSION STYLE	SCALE	DESIGN UNITS
		INCH ONLY	4:1	INCH
DRAWN BY		DATE	TITLE	
C. STEVENS		2000/08/03	TERMINAL, FT VVR (CAT# 7315)	
CHECKED BY		DATE	MATERIAL NO. SD-38002-064	
R. KEMP		2000/08/03		
APPROVED BY		DATE	MATERIAL NO. SD-38002-064	
L. ROTHBAUS		2000/08/07		
ANGULAR ± 1°		MATERIAL NO. SD-38002-064		
DRAFT WHERE APPLICABLE MUST REMAIN WITHIN DIMENSIONS		SEE CHART		SHEET NO. 1 OF 1
THIS DRAWING CONTAINS INFORMATION THAT IS PROPRIETARY TO MOLEX INCORPORATED AND SHOULD NOT BE USED WITHOUT WRITTEN PERMISSION				

INITIAL RELEASE	QUALITY SYMBOLS
EC NO: WNA2009-0426	▽=0
DRWN: JENC INAS 2009/02/06	▽=0
CHKD: CYORK 2009/02/10	
APPR: JMACNEIL 2009/02/10	
REV	DESCRIPTION
A	