

Preface

The Atmel® SAM E70 Xplained evaluation kit is a hardware platform to evaluate the Atmel ATSAME70Q21 microcontroller.

Supported by the Atmel Studio integrated development platform, the kit provides easy access to the features of the ATSAME70Q21 and explains how to integrate the device in a custom design.

The Xplained Pro MCU series evaluation kits include an on-board Embedded Debugger, and no external tools are necessary to program or debug the ATSAME70Q21.

The Xplained Pro extension series evaluation kits offers additional peripherals to extend the features of the board and ease the development of custom designs.

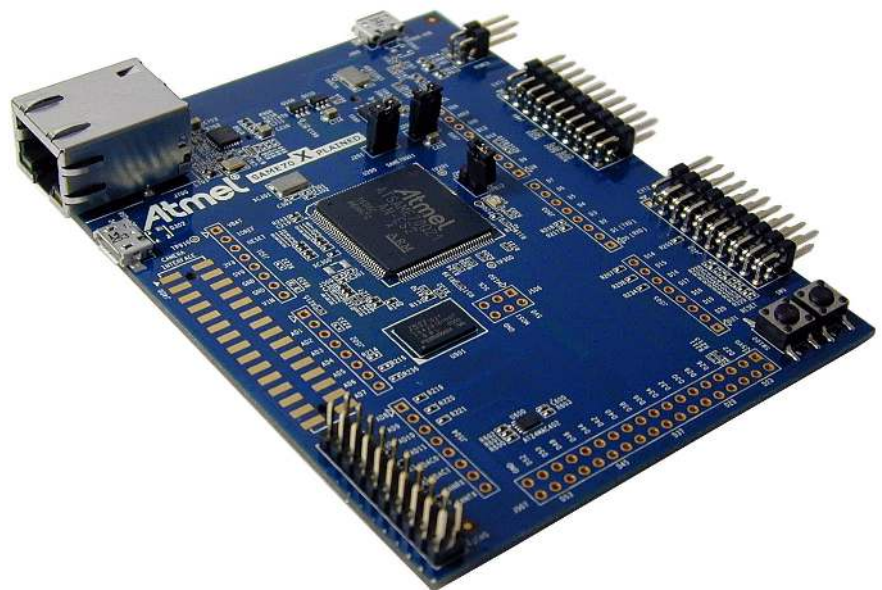

Table of Contents

Preface.....	1
1. Introduction.....	3
1.1. Kit Contents.....	3
1.2. Related Items.....	3
1.3. Kit Overview.....	3
2. Getting Started.....	6
2.1. Xplained Pro Quick Start.....	6
2.2. Design documentation and relevant links.....	6
3. Xplained Pro.....	7
3.1. Embedded Debugger.....	7
3.2. Hardware Identification System.....	7
3.3. Power Sources.....	8
3.4. Xplained Pro Standard Extension Header.....	8
3.5. Xplained Pro Power Header.....	9
4. Hardware User Guide.....	11
4.1. Microcontroller.....	11
4.2. Power Distribution.....	11
4.3. Connectors.....	12
4.4. Peripherals.....	30
4.5. Zero Ohm Resistors.....	38
4.6. Embedded Debugger Implementation.....	41
5. Board Schematics.....	44
6. Board Layout.....	51
7. Evaluation Board/kit Important Notice.....	57

1. Introduction

This user guide introduces the Atmel SAME70-XPLD evaluation kit and describes the development and debugging capabilities for applications running on a SAM E70 ARM-based embedded microcontroller.

1.1. Kit Contents

- Boards
 - One SAME70-XPLD board
- Cables
 - One Micro-AB type USB cable

1.2. Related Items

- [Atmel SAM E70 Series Datasheet](#)

1.3. Kit Overview

1.3.1. Evaluation Kit Architecture

Figure 1-1 Evaluation Kit Architecture

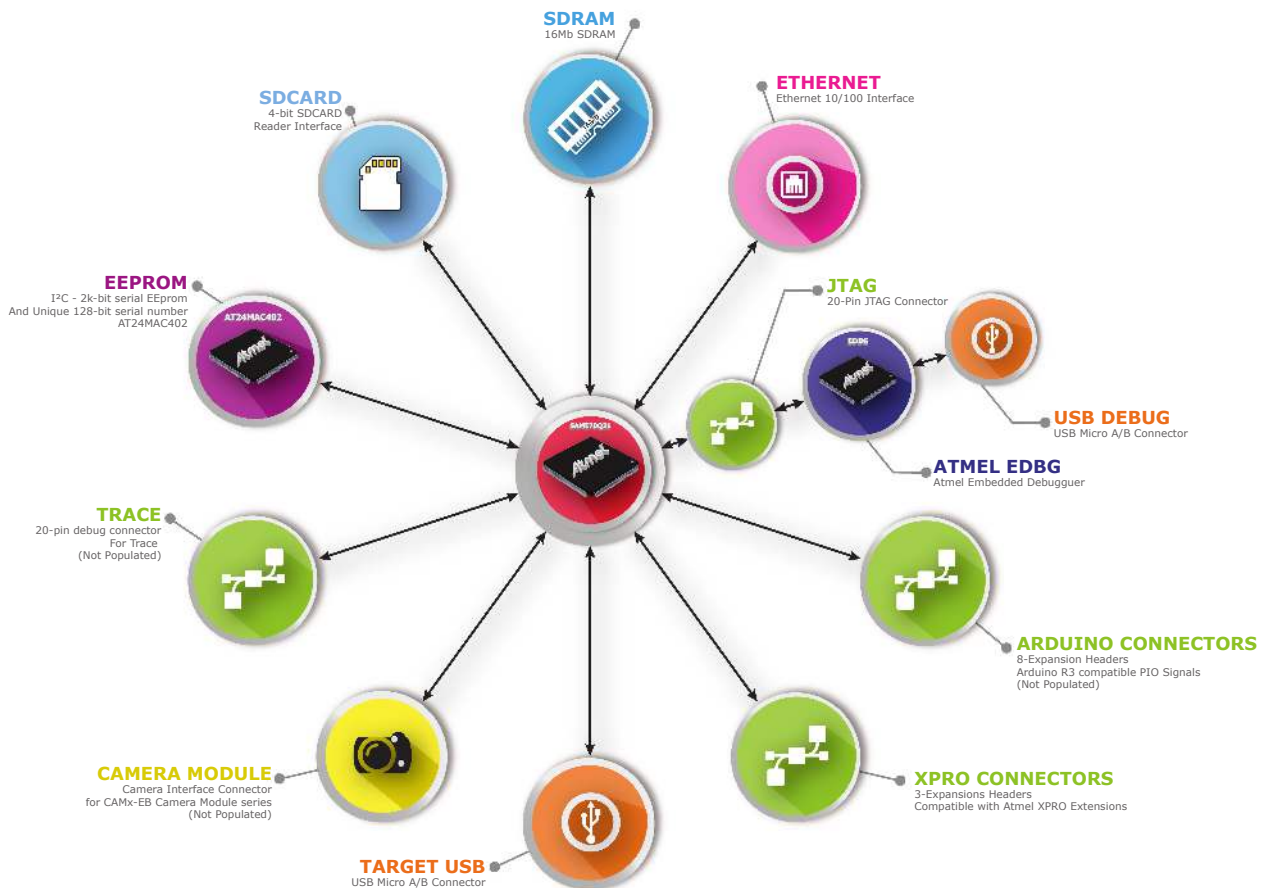

1.3.2. Evaluation Kit Specifications

Table 1-1 Evaluation Kit Specifications

Characteristic		Specifications
Temperature	Operating	0°C to +70°C
	Storage	-40°C to +85°C
Relative Humidity		0 to 90% (non-condensing)
RoHS status		Compliant
Ordering code		ATSAME70-XPLD

1.3.3. Board Features

Table 1-2 Board Specifications

Characteristics	Specifications
PCB characteristics	83.5 × 105 × 16mm (4 layers)
Processor	ATSAME70Q21 (144-lead LQFP package) ARM Cortex-M7 Processor.
Processor clock sources	12 MHz crystal oscillator 32.768 kHz crystal oscillator (not populated)
EEPROM	One AT24MAC402 EEPROM
SDRAM	One IS42S16100E 16 Mb SDRAM
SD/MMC	One 4-bit SD card connector
USB	One Micro-AB USB device One Micro-AB USB for EDBG debug interface
Camera interface	Camera Extension Header for connection with ISI Modules (not populated)
Ethernet	One Ethernet PHY (RMII 10/100)
Debug port	One JTAG interface connector One ETM Trace interface connector (not populated)
Expansion connectors	Three Atmel XPRO Extension Headers Arduino R3 compatible set of headers (not populated) GPIO, TWI, SPI, USART, UART and Audio interfaces are accessible via these headers
Board supply voltage	5V from USB target, from USB Debug or from Arduino shield On-board power regulation is performed by a 3.3V LDO
User interface	Reset and free user pushbutton One green user LED

1.3.4. Board Overview

The Atmel SAME70-XPLD is a hardware platform to evaluate the Atmel ATSAME70Q21.

It offers a set of features that enables the ATSAME70Q21 user to get started with the SAM V71, SAM V70, SAM E70 and SAM S70 peripherals right away and to get an understanding of how to integrate the device in their own design.

The SAME70-XPLD board is equipped with the interface connectors described in [Table 1-3](#).

Table 1-3 SAME70-XPLD Board Interface Connectors

Header	Interfaces to
J302	USB A device. Supports USB device using a Micro-AB connector
J400	Camera Interface Connector (not populated)
J401-J402	Atmel XPRO expansion connectors
J403	Connector for Trace (not populated) (Footprint available on bottom side)
J406	JTAG, 20-pin connector
J500–J507	Expansion connectors with Arduino R3 compatible PIO signals (not populated)
J600	SD/MMC connector (available on bottom side)
J700	Ethernet ETH1
J900	Debug USB interface. Supports USB device using a Micro-AB connector. Interface used for target debug

Figure 1-2 SAME70-XPLD Board Overview

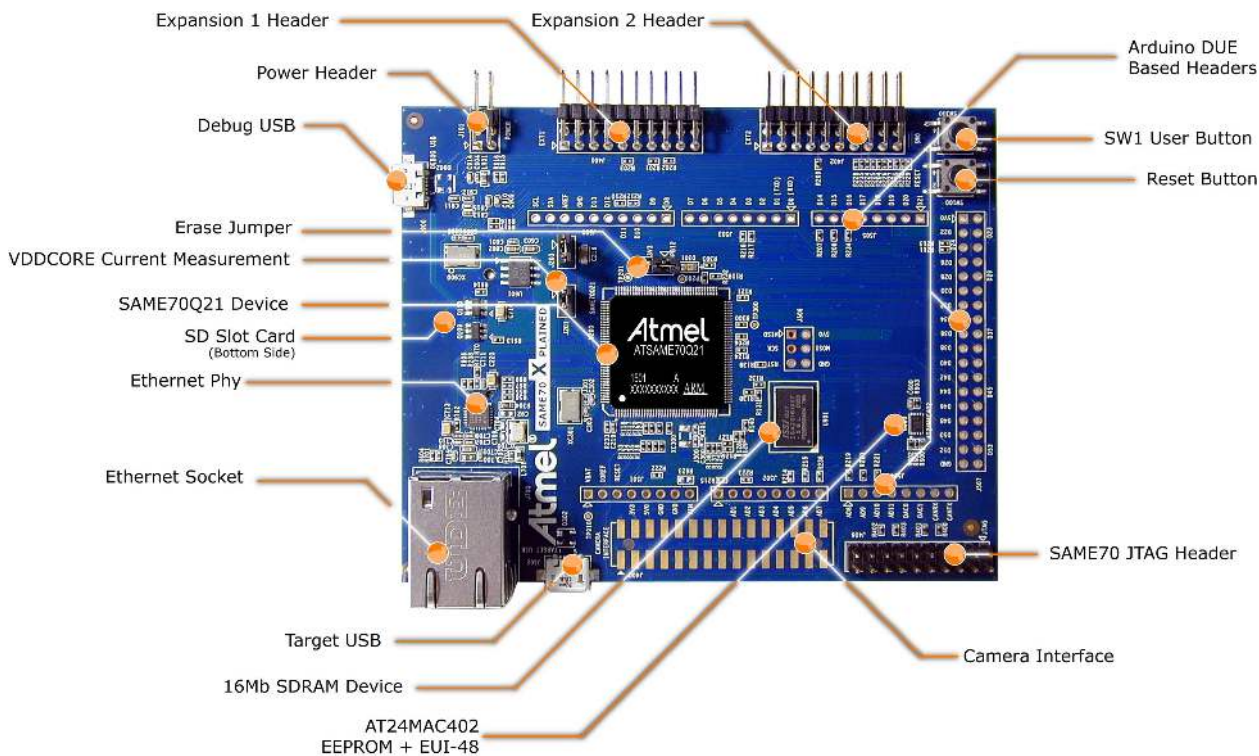

2. Getting Started

2.1. Xplained Pro Quick Start

Three steps to start exploring the Atmel Xplained Pro platform:

1. Download [Atmel Studio](#).
2. Launch Atmel Studio.
3. Connect a USB cable (Standard-A to Micro-B or Micro-AB) between the PC and the DEBUG USB port of the board.

When the Atmel SAME70-XPLD is connected to your computer for the first time, the operating system will perform a driver software installation. The driver file supports both 32- and 64-bit versions of Microsoft® Windows® XP, Windows Vista®, Windows 7, and Windows 8.

Once the board is powered, Atmel Studio will auto detect which kind of MCU and extension board(s) are connected. Atmel Studio will present links to relevant information like datasheets and kit documentation. The kit landing page in Atmel Studio also has the option to launch Atmel Software Framework (ASF) example applications for the kit. The SAM E70 device is programmed and debugged by the on-board Embedded Debugger and therefore no external programmer or debugger tool is needed.

2.2. Design documentation and relevant links

The following list contains links to the most relevant documents and software for SAME70-XPLD:

- [Xplained Pro products](#) - Atmel Xplained Pro is a series of small-sized and easy-to-use evaluation kits for Atmel microcontrollers and other Atmel products. It consists of a series of low-cost MCU boards for evaluation and demonstration of features and capabilities of different MCU families.
- [Atmel Studio](#) - Free Atmel IDE for development of C/C++ and assembler code for Atmel microcontrollers.
- [Atmel sample store](#) - Atmel sample store where you can order samples of devices.
- [EDBG User Guide](#) - User guide containing more information about the on-board Embedded Debugger.
- [IAR Embedded Workbench® for ARM®](#) - This is a commercial C/C++ compiler that is available for ARM®. There is a 30 day evaluation version as well as a code size limited kick-start version available from their website. The code size limit is 16KB for devices with M0, M0+, and M1 cores and 32KB for devices with other cores.
- [Atmel Data Visualizer](#) - Atmel Data Visualizer is a program used for processing and visualizing data. Data Visualizer can receive data from various sources such as the Embedded Debugger Data Gateway Interface found on Xplained Pro boards and COM ports.
- [Design Documentation](#) - Package containing schematics, BOM, assembly drawings, 3D plots, layer plots etc.
- [Hardware Users Guide in PDF format](#) - PDF version of this User Guide.

3. Xplained Pro

Xplained Pro is an evaluation platform that provides the full Atmel microcontroller experience. The platform consists of a series of Microcontroller (MCU) boards and extension boards, which are integrated with Atmel Studio, have Atmel Software Framework (ASF) drivers and demo code, support data streaming, and more. Xplained Pro MCU boards support a wide range of Xplained Pro extension boards, which are connected through a set of standardized headers and connectors. Each extension board has an identification (ID) chip to uniquely identify which boards are connected to an Xplained Pro MCU board. This information is used to present relevant user guides, application notes, datasheets, and example code through Atmel Studio.

3.1. Embedded Debugger

The SAME70-XPLD contains the Atmel Embedded Debugger (EDBG) for on-board debugging. The EDBG is a composite USB device of three interfaces: a debugger, Virtual COM Port, and a Data Gateway Interface (DGI).

Together with Atmel Studio, the EDBG can program and debug the ATSAME70Q21. On the SAME70-XPLD, the SWD interface is connected between the EDBG and the ATSAME70Q21.

The Virtual COM Port is connected to a UART on the ATSAME70Q21 and provides an easy way to communicate with the target application through terminal software. It offers variable baud rate, parity, and stop bit settings. Note that the settings on the ATSAME70Q21 must match the settings applied in the terminal software.

Note: If not set automatically, data terminal ready (DTR) must be set in the terminal software.

The DGI consists of several physical interfaces for communication with the host computer. Communication over the interfaces are bidirectional. It can be used to send events and values from the ATSAME70Q21 or as a generic printf-style data channel. Traffic over the interfaces can be timestamped on the EDBG for more accurate tracing of events. Note that timestamping imposes an overhead that reduces maximal throughput. [Atmel Data Visualizer](#) is used to send and receive data through DGI.

For further documentation on the EDBG, see the [EDBG User Guide](#).

3.2. Hardware Identification System

All Xplained Pro compatible extension boards have an Atmel ATSHA204 CryptoAuthentication™ chip mounted. This chip contains information that identifies the extension with its name and some extra data. When an Xplained Pro extension is connected to an Xplained Pro MCU board the information is read and sent to Atmel Studio. The Atmel Kits extension, installed with Atmel Studio, will give relevant information, code examples, and links to relevant documents. The table below shows the data fields stored in the ID chip with example content.

Table 3-1 Xplained Pro ID Chip Content

Data field	Data type	Example content
Manufacturer	ASCII string	Atmel\0'
Product Name	ASCII string	Segment LCD1 Xplained Pro\0'
Product Revision	ASCII string	02\0'
Product Serial Number	ASCII string	1774020200000010\0'

Data field	Data type	Example content
Minimum Voltage [mV]	uint16_t	3000
Maximum Voltage [mV]	uint16_t	3600
Maximum Current [mA]	uint16_t	30

3.3. Power Sources

The SAME70-XPLD kit can be powered by several power sources listed in the table below.



Warning: The 3.3V power domain is locally generated and must never be supplied from external sources or this would damage the on-board regulators.

Table 3-2 SAME70-XPLD Power Sources

Power input	Voltage requirements	Connector marking
Embedded debugger USB	4.4V to 5.25V (USB spec.)	DEBUG USB
Target USB	4.4V to 5.25V (USB spec.)	TARGET USB
Arduino connector	5.0V typically	J501 (pin 5)

In case of USB power sources, the board automatically detects and switches to the available one. If the two are present (which is no problem whatsoever) the following priority applies:

1. Target USB (J302 connector)
2. Embedded Debugger USB (J900 connector)



Info: USB sources supposedly provide a maximum current of 500mA. Calculate the power budget of your system, there is a possibility this could be not enough if your SAME70-XPLD also connects to power demanding extension boards.

The optional 5Vcc power source from the Arduino connector J501 is connected in parallel to the USB power switching system, hence the following warning:



Warning: do not power the board from the Arduino shield (J501) when either of the two USB sources are connected. Doing so could damage the board and potentially also damage the USB port of your PC.

3.4. Xplained Pro Standard Extension Header

All Xplained Pro kits have one or more dual row, 20-pin, 100mil extension header. Xplained Pro MCU boards have male headers, while Xplained Pro extensions have their female counterparts. Note that all pins are not always connected. All connected pins follow the defined pin-out description in the table below.

The extension headers can be used to connect a variety of Xplained Pro extensions to Xplained Pro MCU boards or to access the pins of the target MCU on Xplained Pro MCU boards directly.

Table 3-3 Xplained Pro Standard Extension Header

Pin number	Name	Description
1	ID	Communication line to the ID chip on an extension board
2	GND	Ground
3	ADC(+)	Analog to digital converter, alternatively positive part of differential ADC
4	ADC(-)	Analog to digital converter, alternatively negative part of differential ADC
5	GPIO1	General purpose I/O
6	GPIO2	General purpose I/O
7	PWM(+)	Pulse width modulation, alternatively positive part of differential PWM
8	PWM(-)	Pulse width modulation, alternatively negative part of differential PWM
9	IRQ/GPIO	Interrupt request line and/or general purpose I/O
10	SPI_SS_B/ GPIO	Slave select for SPI and/or general purpose I/O
11	I ² C_SDA	Data line for I ² C interface. Always implemented, bus type.
12	I ² C_SCL	Clock line for I ² C interface. Always implemented, bus type.
13	UART_RX	Receiver line of target device UART
14	UART_TX	Transmitter line of target device UART
15	SPI_SS_A	Slave select for SPI. Should preferably be unique.
16	SPI_MOSI	Master out slave in line of serial peripheral interface. Always implemented, bus type.
17	SPI_MISO	Master in slave out line of serial peripheral interface. Always implemented, bus type.
18	SPI_SCK	Clock for serial peripheral interface. Always implemented, bus type.
19	GND	Ground
20	VCC	Power for extension board

3.5. Xplained Pro Power Header

The power header can only be used as supply for external peripherals or extension boards. Care must be taken not to exceed the total current limitation of the on-board regulator when using the 3.3V pin.

Table 3-4 Xplained Pro Power Header

Pin number	Pin name	Description
1	n/a	not connected
2	GND	Ground
3	VCC_5V0	Output: unregulated 5V (output, derived from one of the input sources)
4	VCC_3V3	Output: regulated 3.3V (output, used as main power supply for the kit)

4. Hardware User Guide

4.1. Microcontroller

The SAME70-XPLD board is built around the ATSAME70Q21 in a 144-lead LQFP package. It is a low-power ARM Cortex-M7 application microcontroller achieving high-performance computing device and embedding a wide range of communication peripherals. It features a combination of user interface functionalities and high data rate IOs, camera interface, 10/100 Ethernet ports, high-speed USB and SD Card.

The ARM Cortex-M7 processor supports SDRAM memory through an EBI interface. An internal 150 MHz multi-layer AHB bus architecture associated with 24 XDMA channels, 384 Kbytes of SRAM and 2048 Kbytes of Flash sustains the high bandwidth required by the microcontroller and the high-speed peripherals.

Figure 4-1 SAM E70 Block Diagram

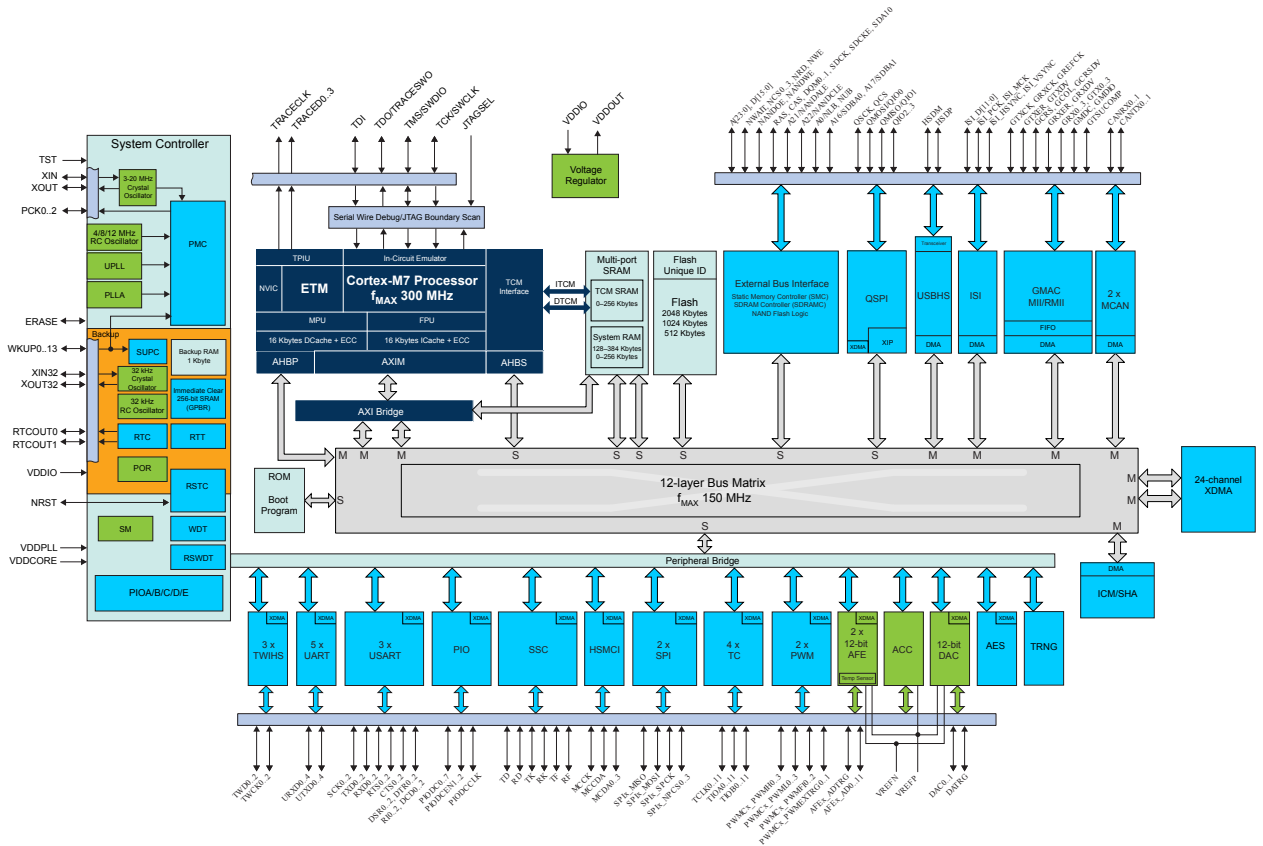

4.2. Power Distribution

The SAME70-XPLD has two power sources as described in the figure [Power Supply Block Diagram](#).

The kit can be powered from the EDBG USB or from the target USB. The kit automatically selects a source to draw power. Priority is given to TARGET USB power input.

Figure 4-2 Power Supply Block Diagram

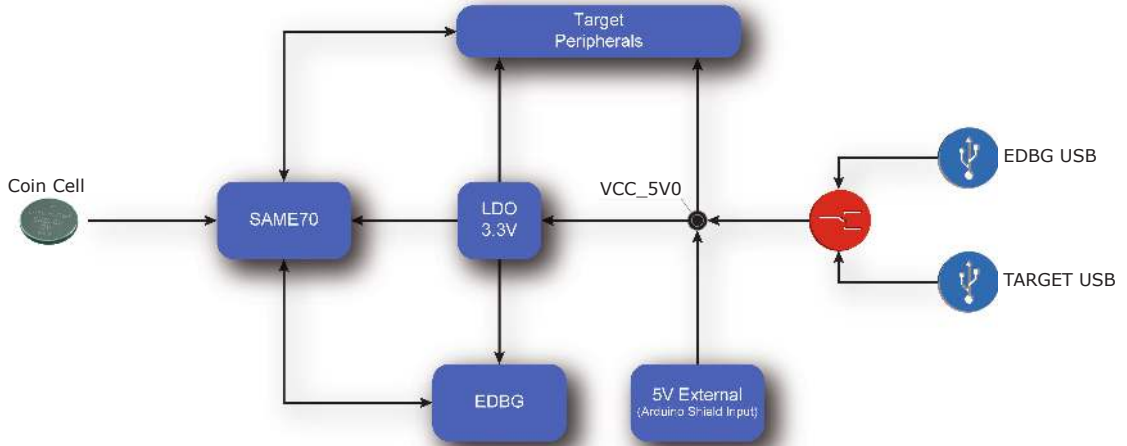

4.3. Connectors

These sections describe the implementation of all connectors and headers on SAME70-XPLD and their connection to the ATSAME70Q21. The tables of connections in these sections also describe which signals are shared between the headers and on-board functionality. The figure below shows all available connectors and jumpers on the SAME70-XPLD.

Figure 4-3 SAME70-XPLD Connector Overview

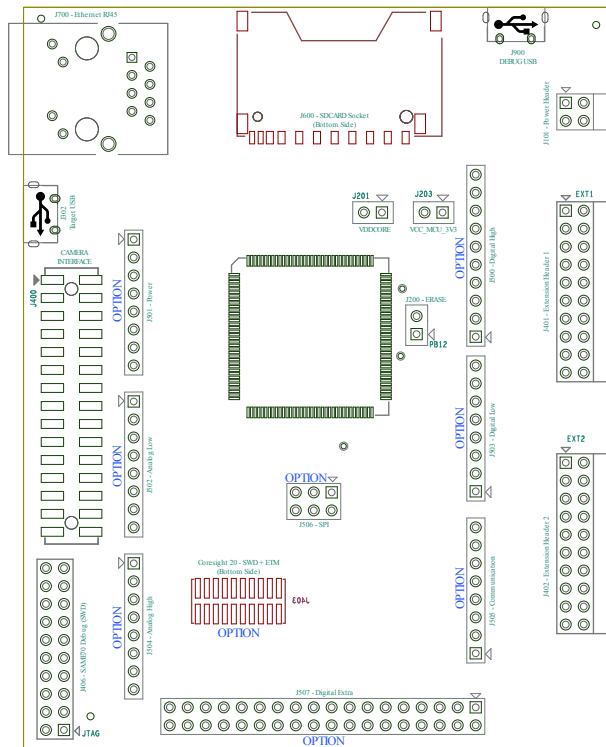

4.3.1. Extension Headers

The Xplained Pro headers EXT1 and EXT2 on SAME70-XPLD give access to the I/O of the microcontroller in order to expand the system, e.g. by connecting extensions boards. The headers have a pitch of 2.54mm.

Table 4-1 EXT1 Header

EXT1 Pin	SAM E70 Pin	Function	Shared Functionality
1 [ID]	--	ID_EXT1	Signal connected to Embedded Debugger
2 [GND]	--	--	Ground Connection with Extension Board
3 [ADC(+)]	PC31	AFE1_AD6	J502 Header & J504 Header (Arduino Shield)
4 [ADC(-)]	PA19	AFE0_AD8	J502 Header (Arduino Shield)
5 [GPIO1]	PB3	GPIO/RTS0	Camera Connector , EXT2 Header , J504 Header & J507 Header (Arduino Shield)
6 [GPIO2]	PB2	GPIO/CTS0	EXT2 Header , J504 Header & J507 Header (Arduino Shield)
7 [PWM(+)]	PA0	PWMC0_H0	--
8 [PWM(-)]	PC30	TIOB5	J502 Header (Arduino Shield)
9 [IRQ/GPIO]	PD28	WKUP5	Camera Connector , Embedded Debugger , J503 Header & J505 Header (Arduino Shield)
10 [SPI_SS_B/GPIO]	PC17	GPIO	--
11 [I2C_SDA]	PA3	TWD0	Camera Connector , EXT2 Header , J500 Header (Arduino Shield), AT24MAC402 , Embedded Debugger
12 [I2C_SCL]	PA4	TWCK0	Camera Connector , EXT2 Header , J500 Header (Arduino Shield), AT24MAC402 , Embedded Debugger
13 [UART_RX]	PB0	RXD0	EXT2 Header , J505 Header & J507 Header (Arduino Shield)
14 [UART_TX]	PB1	TXD0	EXT2 Header , J505 Header & J507 Header (Arduino Shield)
15 [SPI_SS_A]	PD25	SPI0_NPCS1	Camera Connector , J500 Header (Arduino Shield)
16 [SPI_MOSI]	PD21	SPI0_MOSI	EXT2 Header , Camera Connector , J500 Header & J506 Header (Arduino Shield), Embedded Debugger
17 [SPI_MISO]	PD20	SPI0_MISO	EXT2 Header , J500 Header & J506 Header (Arduino Shield), Embedded Debugger
18 [SPI_SCK}	PD22	SPI0_SPCK	EXT2 Header , Camera Connector , J500 Header & J506 Header (Arduino Shield), Embedded Debugger

EXT1 Pin	SAM E70 Pin	Function	Shared Functionality
19 [GND]	--	--	Ground Connection with Extension Board
20 [VCC]	--	--	Power For Extension Board (3.3V only)

Table 4-2 EXT2 Header

EXT2 Pin	SAM E70 Pin	Function	Shared Functionality
1 [ID]	--	ID_EXT2	Signal connected to Embedded Debugger
2 [GND]	--	--	Ground Connection with Extension Board
3 [ADC(+)]	PD30	AFE0_AD0	Camera Connector, J502 Header & J503 Header (Arduino Shield)
4 [ADC(-)]	PC13	AFE1_AD1	J502 Header (Arduino Shield)
5 [GPIO1]	PA6	GPIO	Camera Connector, J503 Header (Arduino Shield)
6 [GPIO2]	PD11	GPIO	Camera Connector, J500 Header & J503 Header (Arduino Shield)
7 [PWM(+)]	PC19	PWMC0_H2	Camera Connector, J503 Header (Arduino Shield)
8 [PWM(-)]	PD26	PWMC0_L2	J502 Header (Arduino Shield)
9 [IRQ/GPIO]	PA2	WKUP2	J503 Header (Arduino Shield), Embedded Debugger
10 [SPI_SS_B/ GPIO]	PA24	GPIO	Camera Connector, J507 Header (Arduino Shield)
11 [I2C_SDA]	PA3	TWD0	Camera Connector, EXT1 Header, J500 Header (Arduino Shield), AT24MAC402, Embedded Debugger
12 [I2C_SCL]	PA4	TWCK0	Camera Connector, EXT1 Header, J500 Header (Arduino Shield), AT24MAC402, Embedded Debugger
13 [UART_RX]	PA21	RXD1	J507 Header (Arduino Shield), Embedded Debugger
14 [UART_TX]	PB4	TXD1	J507 Header (Arduino Shield), Embedded Debugger

EXT2 Pin	SAM E70 Pin	Function	Shared Functionality
15 [SPI_SS_A]	PB3	USART_SPI_NSS_MASTER_0	EXT1 Header, Camera Connector, J504 Header & J507 Header (Arduino Shield)
	PD31	USART_SPI_NSS_MASTER_0	Camera Connector
	PB2	USART_SPI_NSS_SLAVE	EXT1 Header, J504 Header & J507 Header (Arduino Shield)
	PD27	SPI0_NPCS3	Camera Connector, J503 Header & J505 Header (Arduino Shield)
16 [SPI_MOSI]	PD21	SPI0_MOSI	EXT1 Header, Camera Connector, J500 Header & J506 Header (Arduino Shield), Embedded Debugger
	PB1	USART_SPI_MOSI	EXT1 Header, J505 Header & J507 Header (Arduino Shield)
17 [SPI_MISO]	PD20	SPI0_MISO	EXT1 Header, J500 Header & J506 Header (Arduino Shield), Embedded Debugger
	PB0	USART_SPI_MOSI	EXT1 Header, J505 Header & J507 Header (Arduino Shield)
18 [SPI_SCK}	PD22	SPI0_SPCK	EXT1 Header, Camera Connector, J500 Header & J506 Header (Arduino Shield), Embedded Debugger
	PB13	USART_SPI_SPCK	J504 Header & J507 Header (Arduino Shield)
19 [GND]	--	--	Ground Connection with Extension Board
20 [VCC]	--	--	Power For Extension Board (3.3V only)

4.3.2. Arduino Connectors

Five 8-pin, one 10-pin, one 2×3-pin and one 2×18-pin headers footprints (J500 to J507) are implemented on the board to enable the addition of "Arduino shields" extension cards. These accessory boards are various and widely available on the market, often custom developed. Due to the PIO multiplexing of the ATSAME70Q21, various peripheral signals may be connected to each pin. These connectors are mechanically (location and footprint) compatible with the Arduino R3 shields.



Important: As the SAM E70 signals have a voltage level of 3.3V, 5V level shields cannot properly function with SAME70-XPLD.

In addition to its standard IO functionality, the SAM E70 microcontroller can provide alternate functions to external IO lines available on the J500 to J507 headers.

These alternate functions are:

- UARTs: UART1, UART2, UART3, UART4
- USARTs: USART0, USART1, USART2
- SPI: SPI0
- I²C: TWI0, TWI2
- Timer capture and compare: TIOA[0, 2,11], TIOB[5, 7, 8,11], TCLK[1, 2, 5, 8,11]
- Clock out: PCK0, PCK1, PCK2
- PWMs: PWMC0_PWMEXTRG[0,1], PWMC0_PWMH[0:3], PWMC_PWML[0, 2, 3], PWMC1_PWMEXTRG[0,1], PWMC1_PWMFI[0:2], PWMC1_PWMH[0, 2], PWMC1_PWML[0:3]
- DIGITAL AUDIO: TD, TK, TF, RD, RK, RF, GTSUCOMP
- CAN: CANRX0, CANTX0, CANRX1, CANTX1
- Analog: ADVREF, AFE0_AD[0, 6, 8], AFE1_AD[1, 3, 5, 6], DAC[0,1]
- GPIO: MISC
- RESET

Refer to the [SAM E70 Series datasheet](#) for further details on the PIO multiplexing and alternate function selection.



Caution: Like the Arduino Due, SAME70-XPLD runs at 3.3V and the maximum voltage that the I/O pins can tolerate is 3.3V, connecting higher voltages e.g. 5V to those I/O pin could damage the board.



Important: not all pins of the shield connectors are necessarily connected to an I/O of the ATSAME70Q21. Each shield should be checked for compatibility against the SAME70-XPLD schematics before it is purchased and connected.

4.3.2.1. J500 Header

J500 is a 10-pin header with 2.54mm pitch. It is not populated by default and can be used to connect to Arduino Shields. It includes PWM, Timer Counter and I²C interface signals and analog reference.

4.3.2.2. J501 Header

J501 is a 8-pin header with 2.54mm pitch. It is not populated by default and can be used to connect to Arduino Shields. It allows power distribution (3.3V and 5V) to any Arduino Shield connected on the SAME70-XPLD board.

Figure 4-5 J501 Header

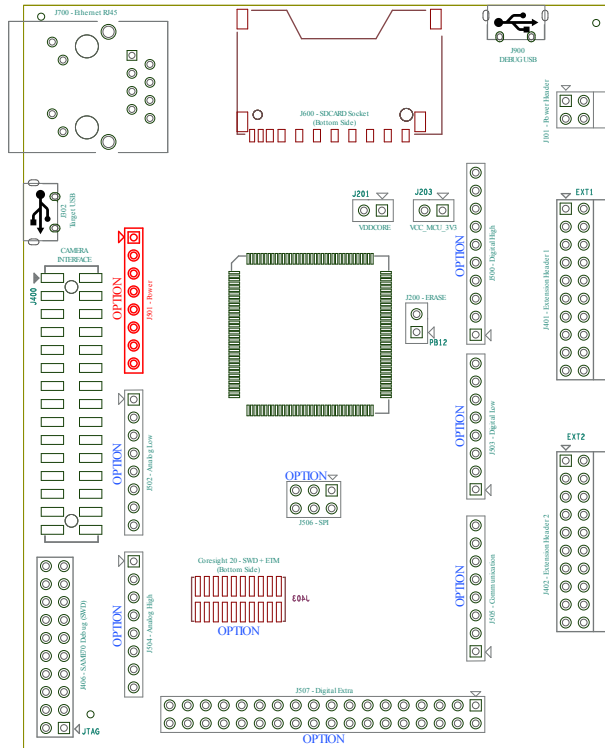

Table 4-4 J501 Header IOs

Pin	PCB Marking	Function
1	VBAT	Not used on SAME70-XPLD board. Connected to testpoint TP910
2	IOREF	ADVREF. Reference voltage for the analog inputs of the SAM E70 microcontroller. Actually connected to 3.3V.
3	RESET	System reset
4	3V3	Main 3.3V supply - generated by the on-board regulator.
5	5V0	Main 5.0V supply (output or input). In case that pin is used as power supply source, do check the recommendations given in Power Sources on page 8 section.
6	GND	System ground
7	GND	System ground
8	VIN	Not connected by default. Optional 5Vcc supply for any Arduino Shield.



Info: Pin 8 is connected to the SAME70-XPLD board through an 0R serial resistor. It is necessary to mount 0R resistor R623 to enable the functionality.

4.3.2.4. J503 Header

J503 is a 8-pin header with 2.54mm pitch. It is not populated by default and can be used to connect to Arduino Shields. It includes PWM, Timer Counter, SPI Chip Select and UART3.

Figure 4-7 J503 Header

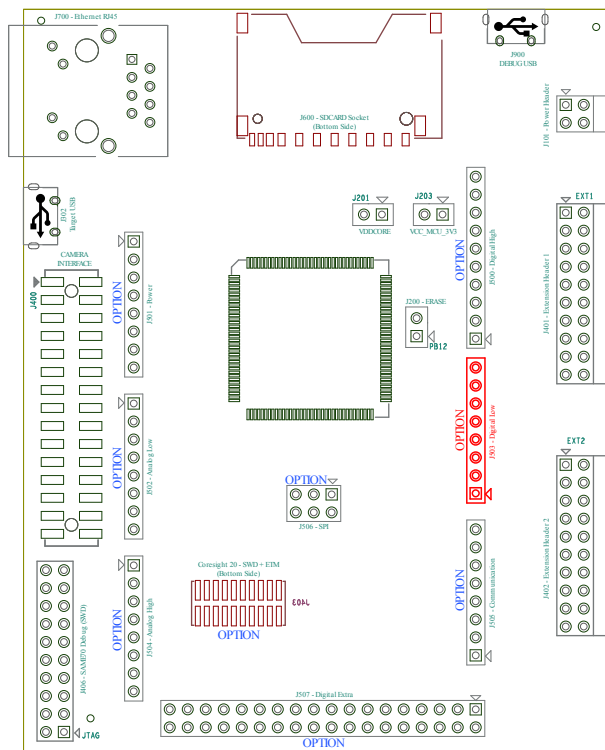

Table 4-6 J503 Header IOs

Pin	PCB Marking	PIO	Primary Function	Alternate Function	
8	D7	PA2	PWMC0_PWMH1	WKUP2	--
7	D6	PC19	PWMC0_PWMH2	--	--
6	D5	PD11	PWMC0_PWMH0	--	--
5	D4	PD27	SPI0_NPCS3	PWMC0_PWML3	TWD2
4	D3	PA6	PCK0	UTXD1	--
		PD10	PWMC0_PWML0	TD	--
3	D2	PA5	PWMC1_PWML3	URXD1	WKUP4
2	D1 (TXD)	PD30	UTXD3	AFE0_AD0	--
4	D0 (RXD)	PD28	URXD3	TWCK2	CANRX1

4.3.2.6. J505 Header

J505 is a 8-pin header with 2.54mm pitch. It is not populated by default and can be used to connect to Arduino Shields. It includes UART0, UART2, UART4 and TWI interfaces.

Figure 4-9 J505 Header

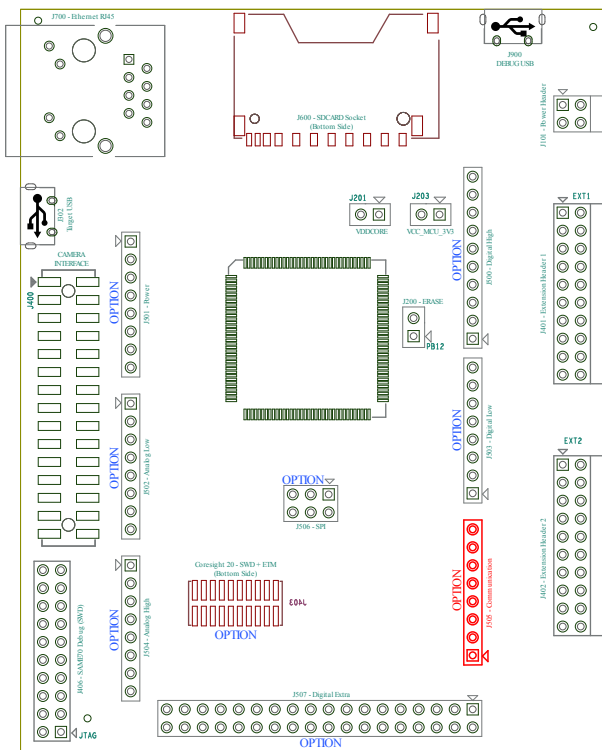

Table 4-8 J505 Header IOs

Pin	PCB Marking	PIO	Primary Function	Alternate Function
8	D14	PB1	TXD0	TK GTSUCOMP
7	D15	PB0	RXD0	TF PWMC0_PWMH0
6	D16	PD16	TXD2	-- PWMC0_PWMH1
5	D17	PD15	RXD2	-- AFE0_AD10
4	D18	PD19	UTXD4	CTS2
3	D19	PD18	URXD4	RTS2
2	D20	PD27	TWD2	SPI0_NPCS3 PWMC0_PWML3
1	D21	PD28	TWCK2	CANRX1 URXD3 WKUP5

4.3.2.7. J506 Header

J506 is a 2x3-pin header with 2.54mm pitch. It is not populated by default and can be used to connect to Arduino Shields. It includes the SPI interface.

Pin	PCB Marking	PIO	Primary Function	Alternate Function		
16	D35	PA12	PWMC1_PWMH0	PWMC0_PWMH1	--	--
17	D36	PA13	PWMC1_PWML1	PWMC0_PWMH2	--	--
18	D37	Not Connected				
19	D38	PB13	SCK0	PWMC0_PWML2	DAC0	PCK0
20	D39	PB2	CTS0	SPI0_NPCS0	CANTX0	AFE0_AD5
21	D40	PB3	RTS0	PCK2	CANRX0	AFE0_AD2
22	D41	PA31	PWMC1_PWMH2	PCK2	SPI0_NPCS1	--
23	D42	Not Connected				
24	D43	PA23	PWMC0_PWMH0	PWMC1_PWML2	SCK1	--
25	D44	PA25	CTS1	PWMC0_PWMH2	--	--
26	D45	PA24	RTS1	PWMC0_PWMH1	--	--
27	D46	PA21	RXD1	PWMC1_PWMF10	AFE0_AD1	PCK1
28	D47	PB4	TXD1	PWMC0_PWMH2	TWD1	--
29	D48	PA30	PWMC1_PWMEXTR G0	PWMC0_PWML2	WKUP11	--
30	D49	PA28	PWMC1_PWMF12	TCLK1	--	--
31	D50	PA18	PWMC1_PWMEXTR G1	PCK2	--	--
32	D51	Not Connected				
33	D52	PC12	CANRX1	AFE1_AD3	TIOB8	--
34	D53	PC14	CANTX1	TCLK8	--	--
35	GND	--	System ground	--	--	--
36	GND	--	System ground	--	--	--

4.3.3. Camera Connector

A 2×15-pin, 100mil pin-header camera connector is implemented to give access to the SAM E70 parallel Image Sensor Interface (ISI).

Figure 4-12 Camera Connector

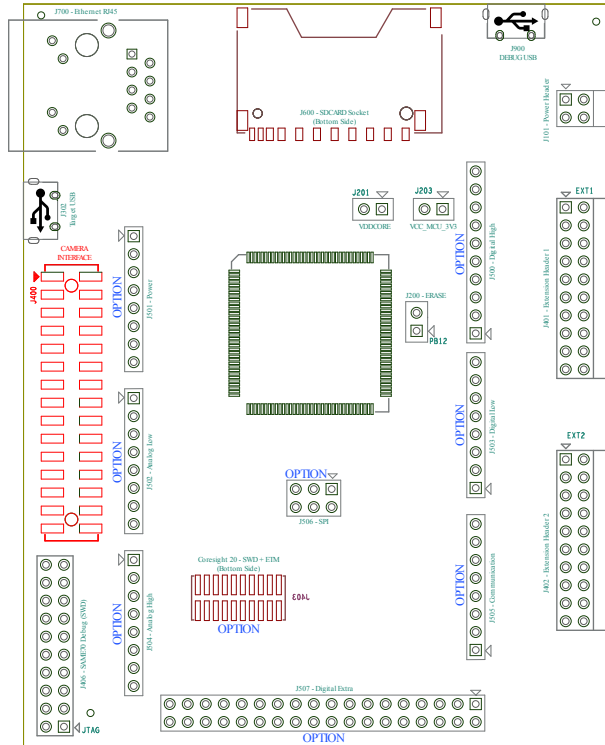

Table 4-11 J400 - Camera Connector

Pin Number	SAM E70 Pin	Function	Shared Functionality
1 - 3	--	VCC_3V3	--
2 - 4	--	GND	--
5	PA13	ISI_RST	J507 Header (Arduino Shield)
6	PC19	ISI_PWD	EXT2 Header, J503 Header (Arduino Shield)
7	PA4	TWCK0	EXT1 Header, EXT2 Header, AT24MAC402, J500 Header (Arduino Shield), Embedded Debugger
8	PA3	TWD0	EXT1 Header, EXT2 Header, J503 Header, J500 Header (Arduino Shield), Embedded Debugger
9	--	GND	--
10	PA6	PCK0	EXT2 Header, J503 Header (Arduino Shield)
11	--	GND	--
12	PD25	ISI_VSYNC	EXT1 Header, J500 Header (Arduino Shield)
13	--	GND	--
14	PD24	ISI_HSYNC	J504 Header (Arduino Shield)
15	--	GND	--
16	PA24	ISI_PCK	EXT2 Header, J507 Header (Arduino Shield)
17	--	GND	--

Pin Number	SAM E70 Pin	Function	Shared Functionality
18	PD22	ISI_D0	EXT1 Header, EXT2 Header, J500 Header & J506 Header (Arduino Shield), Embedded Debugger
19	PD21	ISI_D1	EXT1 Header, EXT2 Header, J500 Header & J506 Header (Arduino Shield), Embedded Debugger
20	PB3	ISI_D2	EXT1 Header, EXT2 Header, J504 Header & J507 Header (Arduino Shield)
21	PA9	ISI_D3	Embedded Debugger
22	PA5	ISI_D4	J503 Header & J507 Header (Arduino Shield)
23	PD11	ISI_D5	EXT2 Header, J500 Header & J503 Header (Arduino Shield)
24	PD12	ISI_D6	Embedded Debugger
25	PA27	ISI_D7	SD Card
26	PD27	ISI_D8	EXT2 Header, J503 Header & J505 Header (Arduino Shield)
27	PD28	ISI_D9	EXT1 Header, J503 Header & J505 Header (Arduino Shield), Embedded Debugger
28	PD30	ISI_D10	EXT2 Header, J502 Header & J503 Header (Arduino Shield)
29	PD31	ISI_D11	EXT2 Header
30	--	GND	--

4.3.4. USB

The SAME70-XPLD board features a Micro-USB connector that implements the SAM E70 USB high speed interface. This connector is labeled as TARGET USB on the board.

Figure 4-13 USB Interface Schematic

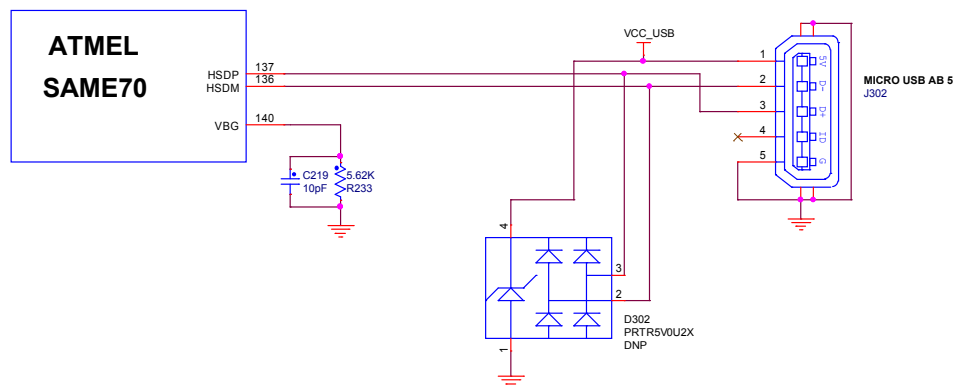

Table 4-12 USB Interface Signal Descriptions

J302 Pin	Mnemonic	Pin on SAM E70	SAM E70 Signal Name	Signal Description
1	VBUS	--	--	5V power
2	DM	136	HSDM	Data minus
3	DP	137	HSDP	Data plus

J302 Pin	Mnemonic	Pin on SAM E70	SAM E70 Signal Name	Signal Description
4	ID	--	--	On-the-go identification
5	Ground	GND	GND	System Ground

4.3.5. Current Measurement Header (VCC_MCU_P3V3)

A 100mil pin-header marked "J203" is located at the upper edge of the SAME70-XPLD. All the power going to the ATSAME70Q21 is routed through this header. To measure the power consumption of the device, remove the jumper and replace it with an ammeter.

Figure 4-14 VCC_MCU_P3V3 Connector Placement J203

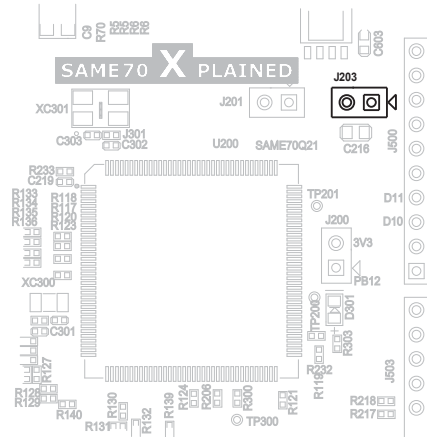

Caution: Removing the jumper from the pin-header while the board is connected to otherwise powered extension boards or systems may cause the ATSAME70Q21 to be powered through its I/O pins. This could cause permanent damage to the device.

4.3.6. VDDCORE Current Measurement

A 100mil pin-header marked "J201" is located at the upper edge of the SAME70-XPLD board. It is not mounted by default and is replaced by a shunt trace between the two pads of the connector. All power to VDDCORE of the ATSAME70Q21 is routed through this header. To measure the power consumption of VDDCORE, cut the shunt trace between the two points, mount a header or solder wires and connect an ammeter.

Figure 4-15 VDDCORE Connector Placement J201

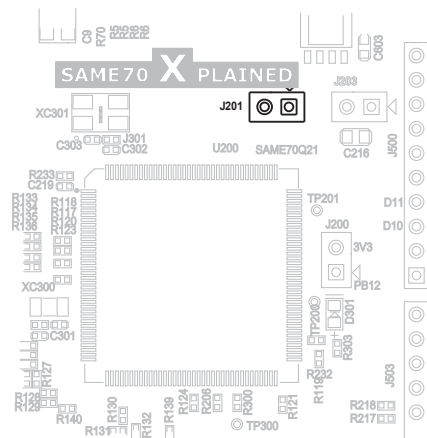



Caution: Leaving J201 open while the main power source is present is to be avoided. This would feed all power pins of the ATSAME70Q21 except VDDCORE, which may cause permanent damage to the device.

4.3.7. Chip Erase Header

The chip erase header J200 is connected to the SAM E70 erase pin (PB12) and the main 3.3V. To erase the contents of the SAM E70 flash memory, set a jumper on J200 and turn the power supply on. The jumper can be removed soon after the power is on (flash erasing takes only 200ms). Using the chip erase jumper is the only way to erase a chip with the security bit set.

Figure 4-16 ERASE Chip Connector Placement J200

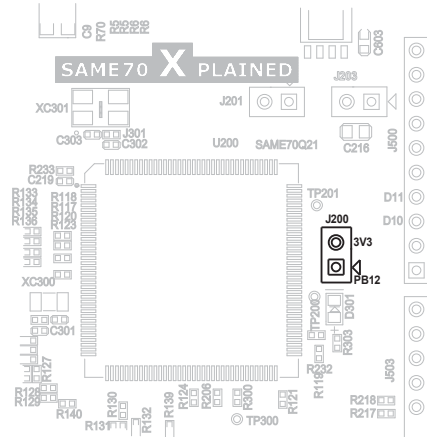

4.3.8. Trace Connector

ATSAME70Q21 supports 4-bit parallel trace. SAME70-XPLD implements a CoreSight 20 20-pin, 50-mil connector footprint on PCB bottom side (not mounted by default).

Figure 4-17 Trace connector location on PCB

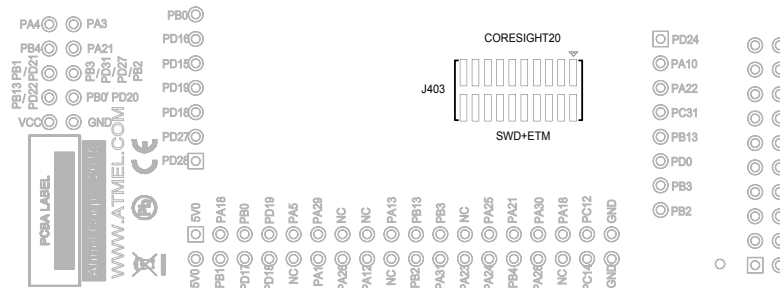

To use the trace functionality, an external debugger with trace support and CoreSight 20 pinout has to be used. The table CoreSight 20-Pin Trace Connector shows the connections on the board.

Figure 4-18 CoreSight 20-Pin Trace Connector Schematic

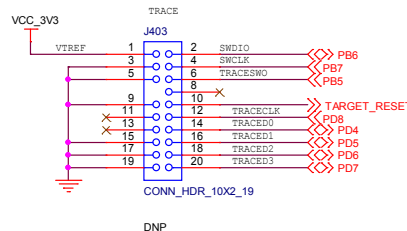

Table 4-13 CoreSight 20-Pin Trace Connector

Pin Number	SAM E70 Pin	Function	Shared With
1-[VTREF]	-	VCC_3V3	--
2-[SWDIO]	PB6	SWDIO	Embedded Debugger
3-5-9-15-17-19[GND]	-	System Ground	--
4-[SWCLK]	PB7	SWCLK	Embedded Debugger
6-[TRACESWO]	PB5	TRACESWO	Embedded Debugger
7-[KEY]	-	-	--
8-11-13[NC]	-	-	--
10-[nSRST]	NRST	NRST	Arduino Connectors and Embedded Debugger
12-[TRACECLK]	PD8	TRACECLK	Ethernet
14-[TRACED0]	PD4	TRACED0	Ethernet
16-[TRACED1]	PD5	TRACED1	Ethernet
18-[TRACED2]	PD6	TRACED2	Ethernet
20-[TRACED3]	PD7	TRACED3	Ethernet

4.4. Peripherals

4.4.1. Clock Circuitry

The SAME70-XPLD board features three clock sources:

- Two crystals for the ATSAME70Q21 processor
- One crystal oscillator for the Ethernet MII/RMII chip

The crystals of the ATSAME70Q21 have cut-straps next to them that can be used to measure the oscillator safety factor. This is done by cutting the strap and adding a resistor across the strap. Information about oscillator allowance and safety factor can be found in the application note [AVR4100](#); information about clock calibration and compensation can be found in the application note [AT03155](#).

Table 4-14 Main Components Associated with the Clock Systems

Quantity	Description	Component Assignment
1	Crystal for internal clock, 12 MHz	XC301
1	Crystal for RTC clock, 32.768 kHz (Not Populated)	XC300
1	Oscillator for Ethernet clock RMII, 25 MHz	XC700

Table 4-15 External Crystals Connected on SAM E70

SAM E70 pin	Function
32.768 kHz External Crystal Connection (Not Populated by default)	
PA7	XIN32: Slow Clock Oscillator Input

SAM E70 pin	Function
PA8	XOUT32: Slow Clock Oscillator Output
12 MHz External Crystal Connection	
PB9	XIN: Main Oscillator Input
PB8	XOUT: Main Oscillator Output

Figure 4-19 SAM E70 Crystals Schematic

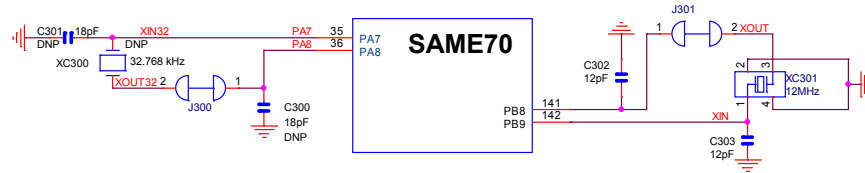

4.4.2. Mechanical Buttons

Two pushbutton switches are available. When a button is pressed, it drives the corresponding I/O line to GND.

- One board reset button (SW100). When pressed and released, this pushbutton causes a power-on reset of the whole board.
- One wakeup pushbutton that brings the processor out of Low-power mode (SW300)

Figure 4-20 Mechanical Button Schematic

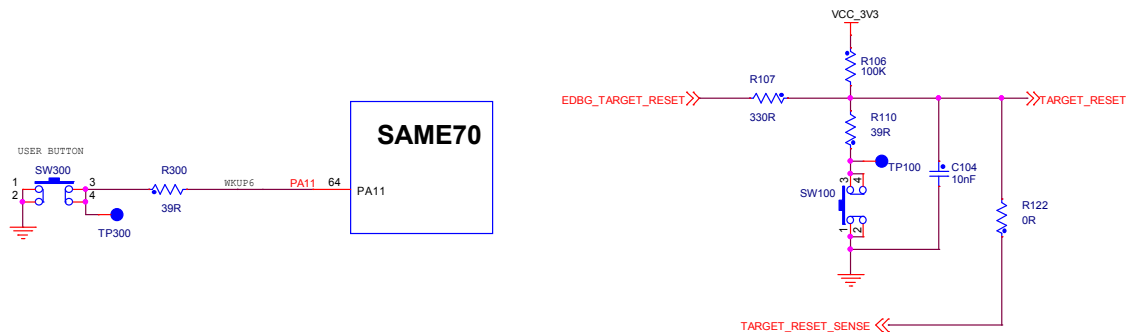

Important: There is no pull-up resistor connected to SW300 button. Remember to enable the internal pull-up in the SAM E70 to use the button.

4.4.3. LEDs

There is one green LED mounted on the SAME70-XPLD. It can be activated by driving the connected I/O line to a low level.

Figure 4-21 LED Indicators Schematic

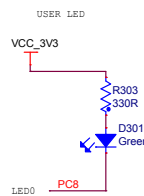

Table 4-16 LED Connection

SAM E70 Pin	Function	Shared With
PC8	Green LED	--

4.4.4. SDRAM

The SAME70-XPLD features one IS42S16100F-5BL, 512K×16×2, 10ns, SDRAM chip. The SDRAM is connected to chip select NCS1. SDRAM access can be configured in the SDRAM Controller in the SAM E70. [Table 4-17 SDRAM Connections](#) on page 32 lists all I/O lines connected to the SDRAM.

Figure 4-22 SDRAM Schematic

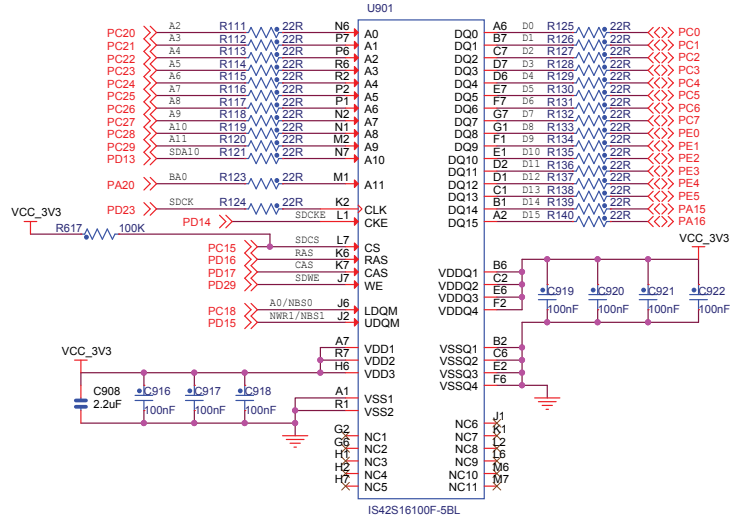

Table 4-17 SDRAM Connections

SAM E70 Pin	Function	SDRAM Function	Shared With
PC0	D0	Data line 0	—
PC1	D1	Data line 1	—
PC2	D2	Data line 2	—
PC3	D3	Data line 3	—
PC4	D4	Data line 4	—
PC5	D5	Data line 5	—
PC6	D6	Data line 6	—
PC7	D7	Data line 7	—
PE0	D8	Data line 8	—
PE1	D9	Data line 9	—
PE2	D10	Data line 10	—
PE3	D11	Data line 11	—
PE4	D12	Data line 12	—
PE5	D13	Data line 13	—

SAM E70 Pin	Function	SDRAM Function	Shared With
PA15	D14	Data line 14	—
PA16	D15	Data line 15	—
PC20	A2	Address line 0	—
PC21	A3	Address line 1	—
PC22	A4	Address line 2	—
PC23	A5	Address line 3	—
PC24	A6	Address line 4	—
PC25	A7	Address line 5	—
PC26	A8	Address line 6	—
PC27	A9	Address line 7	—
PC28	A10	Address line 8	—
PC29	A11	Address line 9	—
PD13	SDA10	Address line 10	—
PA20	BA0	Bank select line 0	—
PD23	SDCK	Clock	—
PD14	SDCKE	Clock Enable	—
PC15	SDCS	Chip Select	—
PD16	RAS	RAS Shield	J505 Header (Arduino Shield)
PD17	CAS	CAS	J507 Header (Arduino Shield)
PD29	SDWE	Write Enable	—
PC18	A0/NBS0	LDQM	—
PD15	NWR1/NBS1	UDQM	J505 Header (Arduino Shield)

4.4.5. SD Card

The SAME70-XPLD has one standard SD card slot, connected to the High-speed Multimedia Card Interface (HSMCI) of the SAM E70. [Table 4-18 SD/MMC Socket J600 Signal Descriptions](#) on page 34 lists all I/O lines connected to the SD card connector.

Figure 4-23 SD/MMC Socket J600 Schematic

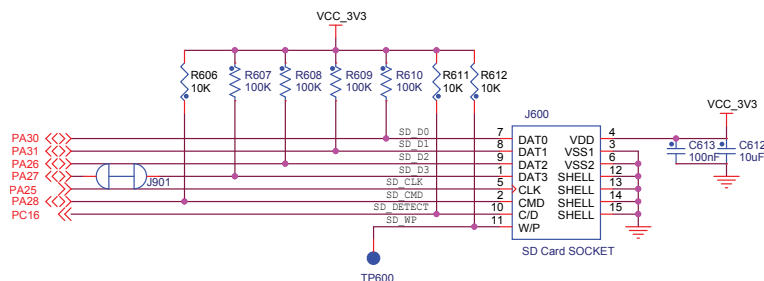

Table 4-18 SD/MMC Socket J600 Signal Descriptions

Pin	Mnemonic	SAM E70 Pin	Signal Description	Shared With
1	DAT3	PA27	Data bit (MCDA3)	Camera Connector
2	CMD	PA28	Command line (MCCDA)	J507 Header (Arduino Shield)
3	VSS	--	Common ground	--
4	VCC	--	Supply voltage 3.3V	--
5	CLK	PA25	Clock / command line (MCCK)	J507 Header (Arduino Shield)
6	VSS	--	Common ground	--
7	DAT0	PA30	Data bit (MCDA0)	J507 Header (Arduino Shield)
8	DAT1	PA31	Data bit (MCDA1)	J507 Header (Arduino Shield)
9	DAT2	PA26	Data bit (MCDA2)	J507 Header (Arduino Shield)
10	C/D	PC16	Card Detect	--
11	WP	--	Protect	--
12	SHELL	--	Connected to Ground	--
13	SHELL	--	Connected to Ground	--
14	SHELL	--	Connected to Ground	--
15	SHELL	--	Connected to Ground	--

4.4.6. Ethernet

The ATSAME70Q21 has a built-in 10/100 Mbps Ethernet IEEE 802.3 compatible MAC with RMII interface. The SAME70-XPLD connects the MAC to a Micrel KSZ8081RNACA RMII physical-layer transceiver (PHY), which is connected to one RJ45 Ethernet connector.

A unique EUI-48™ address is available on every SAME70-XPLD through the on-board AT24MAC402, the EUI-48 address can be used as a MAC address for the KSZ8081RNACA. The address is also programmed into the on-board EDBG.

[Table 4-19 KSZ8081RNACA Connections](#) on page 35 lists all pins connected from the SAM E70 to the Ethernet PHY.



Info: Several of the Ethernet signals are shared with the trace connector and thus there is no Ethernet support if trace is used in an application.

Figure 4-24 RMII Ethernet Schematic

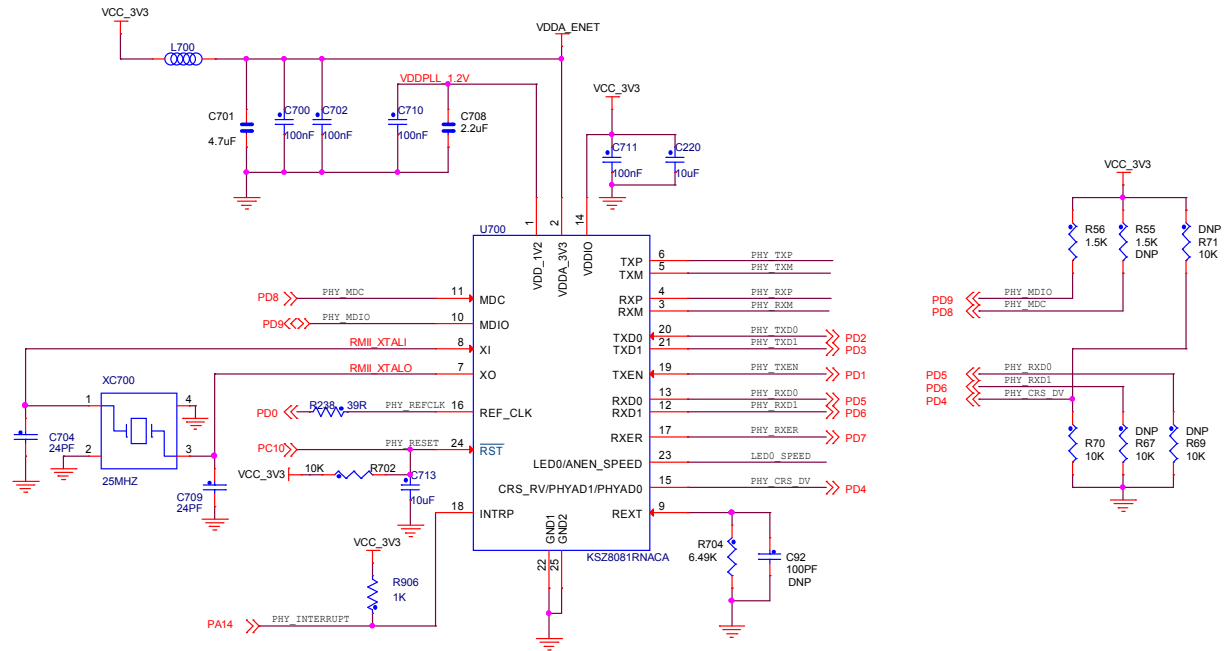

Figure 4-25 Ethernet RJ45 Schematic

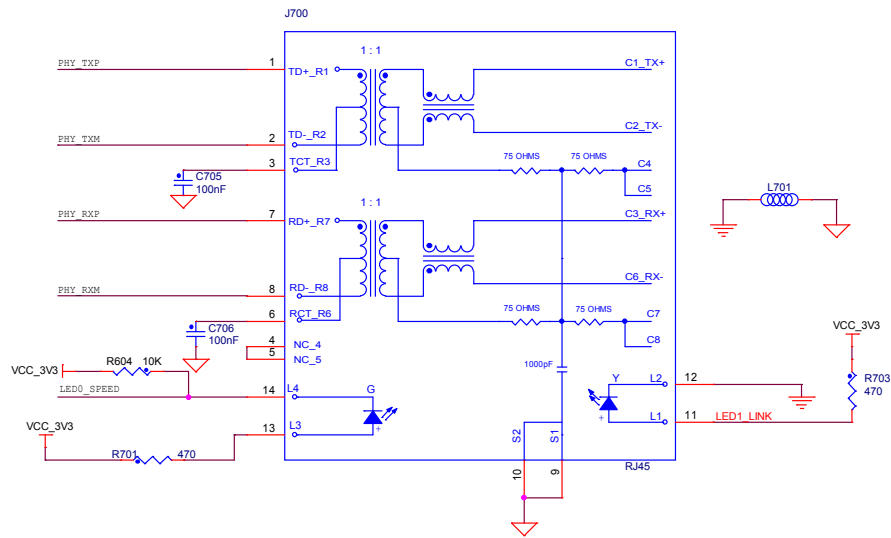

Table 4-19 KSZ8081RNACA Connections

SAM E70 Pin	Exthernet Function	Shared With
PD0	PHY_REFCLK	J504 Header (Arduino Shield)
PD1	PHY_TXEN	—
PD2	PHY_TXD0	—
PD3	PHY_TXD1	—
PD4	PHY_CRS_DV	Trace Connector
PD5	PHY_RXD0	Trace Connector
PD6	PHY_RXD1	Trace Connector

SAM E70 Pin	Exthernet Function	Shared With
PD7	PHY_RXER	Trace Connector
PD8	PHY_MDC	Trace Connector
PD9	PHY_MDIO	–
PC10	PHY_RESET	–
PA14	PHY_INTERRUPT	–

The KSZ8081RNACA also has a set of parameters that are latched in during reset based on I/O pin levels. These configuration options have a default mode on the kit done by external pull-up and pull-down resistors. For detailed information about the configuration, refer to the [KSZ8081RNACA datasheet](#).

Table 4-20 KSZ8081RNACA Configuration

Configuration Name	Default Value on Kit	Default Configuration
PHYAD	0x0h	The PHYs address is 0x0h. It can be set to 0x3h if R70 and R71 are permuted.
AUTONEG	Pull-Up	Auto negotiation enabled and set 100Mbps speed

4.4.7. AT24MAC402

The SAME70-XPLD features one Atmel AT24MAC402 serial EEPROM with an EIA-48 MAC address connected to the SAM E70 through I²C. This AT24MAC402 is configured on the I²C interface with the address 0x37h. It contains a MAC address for use with the Ethernet interface. [Table 4-21 AT24MAC402 Connections](#) on page 36 lists all I/O lines connected to the AT24MAC402 device.

Figure 4-26 AT24MAC402 Schematic

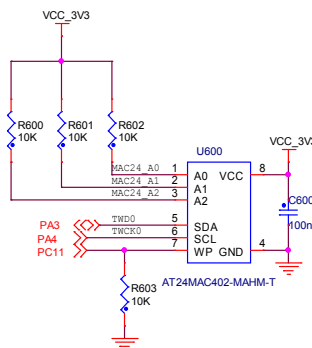

Table 4-21 AT24MAC402 Connections

SAM E70 Pin	Function	AT24MAC402 Function	Shared With
PA3	TWD0	SDA (Serial Data Line)	Camera Connector , EXT1 Header , EXT2 Header , J500 Header (Arduino Shield), Embedded Debugger
PA4	TWCK0	SCL (Serial Click Line)	Camera Connector , EXT1 Header , EXT2 Header , J500 Header (Arduino Shield), Embedded Debugger
PC11	GPIO	WP (Write Protect)	--

4.4.8. Debug JTAG/ICE

A 2×10-pin JTAG header is implemented on the SAME70-XPLD board to enable software development and debugging of the board by using various JTAG emulators. The interface signals have a voltage level of 3.3V.

Figure 4-27 JTAG/ICE Interface Schematic

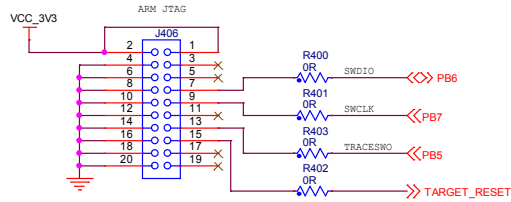

Table 4-22 JTAG/ICE Connector J406 Signal Descriptions

Pin	Signal	Type	Signal Description
1	VTref / VCC_3V3	Input	This is the target reference voltage. It is used to check if the target has power, to create the logic-level reference for the input comparators and to control the output logic levels to the target. It is normally fed from Vdd of the target board and must not have a series resistor.
2	Vsupply / VCC_3V3	Not Used	This pin is not connected in J-Link. It is reserved for compatibility with other equipment. Connect to Vdd or leave open in target system.
3	Not used	NC	This pin is not used by J-Link. If the device may also be accessed via JTAG, this pin may be connected to nTRST, otherwise leave open.
5	Not used	NC	This pin is not used by J-Link. If the device may also be accessed via JTAG, this pin may be connected to TDI, otherwise leave open.
7	SWDIO	I/O	Single bi-directional data pin.
9	SWCLK	Output	Clock signal to target CPU. It is recommended that this pin is pulled to a defined state of the target board. Typically connected to TCK of target CPU.
11	Not used	NC	This pin is not used by J-Link. This pin is not used by J-Link when operating in SWD mode. If the device may also be accessed via JTAG, this pin may be connected to RTCK, otherwise leave open.
13	SWO	Output	Serial Wire Output trace port. (Optional, not required for SWD communication.)
15	RESET	I/O	Target CPU reset signal. Typically connected to the RESET pin of the target CPU, which is typically called "nRST", "nRESET" or "RESET".
17	Not used	NC	This pin is not connected in J-Link.

Pin	Signal	Type	Signal Description
19	Not Used (5V-Supply)	Output	This pin is used to supply power to some eval boards. Not all JLinks supply power on this pin, only the KS (Kickstart) versions. Typically left open on target hardware.
4-6-8-10-12-14-16-18-20	GND	--	System Ground

4.5. Zero Ohm Resistors

The SAME70-XPLD has several zero ohm resistors that can be used to disconnect I/O pins of the ATSAME70Q21 from connectors and on-board ICs and to disconnect power signals. All Arduino pin numbers are listed in [Arduino Connectors](#). The table [Zero Ohm Resistors](#) lists all zero ohm resistors on the kit. The figures [Zero Ohm Resistors - Top Side](#) and [Zero Ohm Resistors - Bottom Side](#) show where they are located.



Info: Note that some zero ohm resistors listed in the table [Zero Ohm Resistors](#) are not mounted by default on the kit.

Table 4-23 Zero Ohm Resistors

Designator	Mounted	From	To	Comments
R122	Yes	TARGET_RESET	TARGET_RESET_SENSE	–
R201	Yes	PB0	J401 - Pin 13	RXD0 on EXT1 Connector
R202	Yes	PB1	J401 - Pin 14	TXD0 on EXT1 Connector
R203	Yes	PD28	J401 - Pin 9	
R204	Yes	PD27	J402 - Pin 15	SPI Interface: Chip Select
R205	Yes	J402 - Pin 17	PD20	SPI Interface: MISO Line
R207	Yes	PB1	J505 - Pin 8	Arduino DUE Pin 17
R208	Yes	PB0	J505 - Pin 7	Arduino DUE Pin 18
R209	Yes	PD26	EXT2	–
R210	Yes	PD21	J500 - Pin 4	SPI Interface: MOSI Line - Arduino DUE Pin 20
R211	Yes	PB1	J507 - Pin 4	–
R212	No	PD11	J500 - Pin 4	Used for GTSUCOMP - Arduino DUE Pin 20
R213	Yes	PB0	J507 - Pin 5	
R214	No	PC30	J502 - Pin 6	Arduino DUE Pin 83
R215	Yes	PD26	J502 - Pin 1	Arduino DUE Pin 78
R216	No	PA17	J502 - Pin 7	Arduino DUE Pin 84

Designator	Mounted	From	To	Comments
R217	Yes	PA6	J503 - Pin 4	Arduino DUE Pin 139
R218	No	PD10	J503 - Pin 4	Arduino DUE Pin 139
R219	Yes	PD24	J504 - Pin 1	Arduino DUE Pin 88
R220	Yes	PA10	J504 - Pin 2	Arduino DUE Pin 89
R221	Yes	PA22	J504 - Pin 3	Arduino DUE Pin 90
R222	No	PA13	J400 - Pin 5	Camera Module Reset Command
R223	No	PD22	J400 - Pin 18	ISI Interface: Data Line 0
R224	No	PB3	J402 - Pin 15	Chip Select for USART in SPI Mode with Master Mode
R225	No	PD31	J402 - Pin 15	Chip Select for USART in SPI Mode with Master Mode
R226	No	PB2	J402 - Pin 15	Chip Select for USART in SPI Mode with Slave Mode
R227	No	J402 - Pin 17	PB0	MISO for USART in SPI Mode
R228	No	PB1	J402 - Pin 16	MOSI for USART in SPI Mode
R229	No	PB13	J402 - Pin 18	SPI Clock for USART in SPI Mode
R230	Yes	PD22	J402 - Pin 18	SPI Interface: Clock Line
R234	Yes	PD16	J505 - Pin 6	Arduino DUE Pin 6
R235	Yes	PD21	J402 - Pin 16	SPI Interface: MOSI Line
R236	No	PC12	J502 - Pin 8	Arduino DUE Pin 85
R400	Yes	PB6	J406 - Pin 7	SWDIO for JTAG Interface
R401	Yes	PB7	J406 - Pin 9	SWCLK for JTAG Interface
R402	Yes	J406 - Pin 15	TARGET_RESET	Reset From JTAG Interface
R403	Yes	PB5	J406 - Pin 13	TRACESWO for JTAG Interface
R623	No	VCC_5V0	VIN	For 5V supply of any shield
R624	Yes	SAM E70 Pin 3	VDDOUT Node	LDO Output for current measurement

Figure 4-29 Zero Ohm Resistors Position – Bottom Side

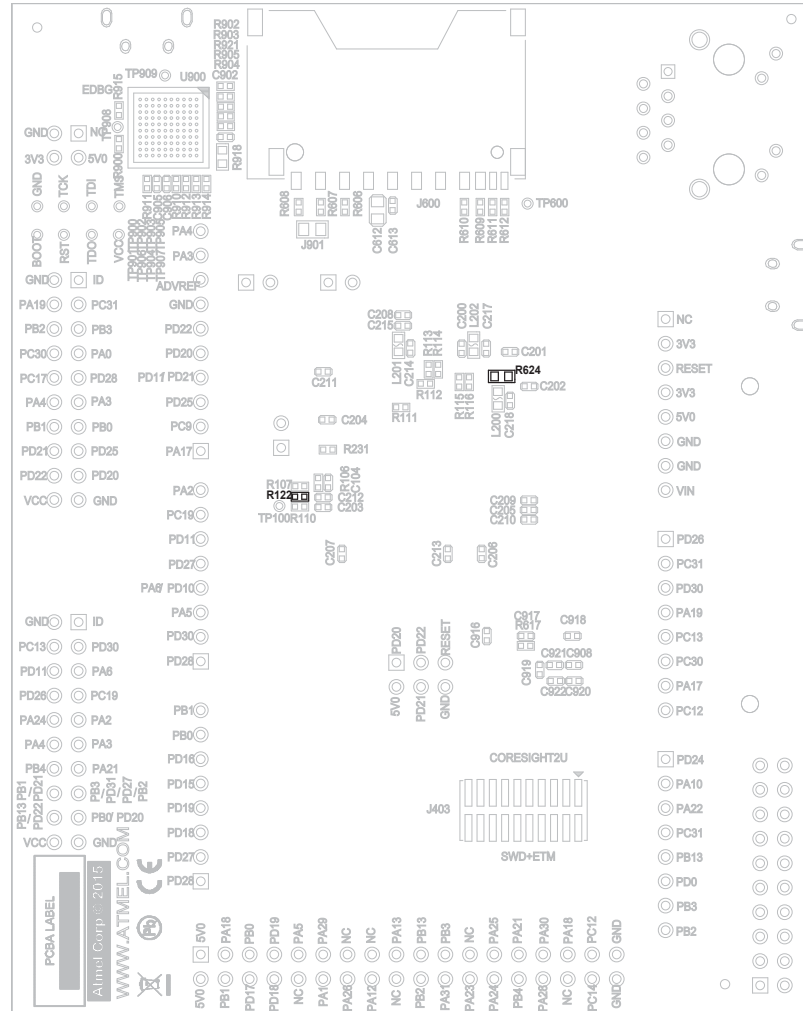

4.6. Embedded Debugger Implementation

SAME70-XPLD contains an Embedded Debugger (EDBG) that can be used to program and debug the ATSAME70Q21 using Serial Wire Debug (SWD). The EDBG also includes:

- a Virtual Com port interface over UART
- an Atmel Data Gateway Interface over SPI
- an I²C channel
- connections to four of the SAM E70 GPIOs

Atmel Studio can be used as a front end for the Embedded Debugger.

4.6.1. Serial Wire Debug

The Serial Wire Debug (SWD) uses two pins to communicate with the target. For further information on how to use the programming and debugging capabilities of the EDBG, see [Embedded Debugger](#) on page 7.

Table 4-24 SWD Connections

SAM E70 Pin	Function	Shared Functionality
PB5	SWO Trace Data	Trace Connector (J403) , Embedded Debugger
PB6	SWD Data	Trace Connector (J403) , Embedded Debugger
PB7	SWD Clock	Trace Connector (J403) , Embedded Debugger
PB12	Erase	Embedded Debugger

4.6.2. Virtual COM Port

The Embedded Debugger acts as a Virtual Com Port gateway by using one of the ATSAME70Q21 UARTs. For further information on how to use the Virtual COM port, see [Embedded Debugger](#) on page 7.

Table 4-25 Virtual COM Port Connections

SAM E70 Pin	Function	Shared Functionality
PB4	TXD1 (SAM E70 UART TX Line)	EXT2 Header , J507 Header , Embedded Debugger
PA21	RXD1 (SAM E70 UART RX Line)	EXT2 Header , J507 Header , Embedded Debugger

4.6.3. Atmel Data Gateway Interface

The Embedded Debugger features an Atmel Data Gateway Interface (DGI) by using either a SPI or I²C port. The DGI can be used to send a variety of data from the ATSAME70Q21 to the host PC. For further information on how to use the DGI interface, see [Embedded Debugger](#) on page 7.

Table 4-26 DGI Interface Connections When Using SPI

SAM E70 Pin	Function	Shared Functionality
PD12	SPI0_NPCS2 (Slave Select)	Camera Connector , Embedded Debugger
PD20	SPI0_MISO (Master In, Slave Out)	EXT1 Header , EXT2 Header , J500 Header , J506 Header , Embedded Debugger
PD21	SPI0_MOSI (Master Out - Slave In)	EXT1 Header , EXT2 Header , J500 Header , J506 Header , Camera Connector , Embedded Debugger
PD22	SPI0_SPCK	EXT1 Header , EXT2 Header , J500 Header , J506 Header , Camera Connector , Embedded Debugger

Table 4-27 DGI Interface Connections When Using I²C

SAM E70 Pin	Function	Shared Functionality
PA3	TWD0 (I ² C Data Line)	EXT1 Header , EXT2 Header , J500 Header , AT24MAC402 , Camera Connector , Embedded Debugger
PA4	TWCK0 (I ² C Clock Line)	EXT1 Header , EXT2 Header , J500 Header , Camera Connector , Camera Connector , Embedded Debugger

Four GPIO lines are connected to the Embedded Debugger. The EDBG can monitor these lines and timestamp pin value changes. This makes it possible to accurately timestamp events in the SAM E70 application code. For further information on how to configure and use the GPIO monitoring features, see [Embedded Debugger](#) on page 7.

Table 4-28 GPIO Lines Connected to the EDBG

SAM E70 Pin	Function	Shared Functionality
PA9	DGI_GPIO0	Camera Connector, Embedded Debugger
PA23	DGI_GPIO1	J507 Header, Embedded Debugger
PD28	DGI_GPIO2	EXT1 Header, Camera Connector, J503 Header, J505 Header, Embedded Debugger
PA2	DGI_GPIO3	EXT2 Header, J503 Header, Embedded Debugger

5. Board Schematics

This section contains the following schematics:

- Block Diagram
- SAM E70 Device, Crystals and USB Device interface
- Atmel XPRO Extended Connectors, Debug and Camera Interface Connectors
- Arduino R3 Extended Connectors
- Memories and Power
- Ethernet 10/100
- EDBG Interface

Figure 5-1 Block Diagram

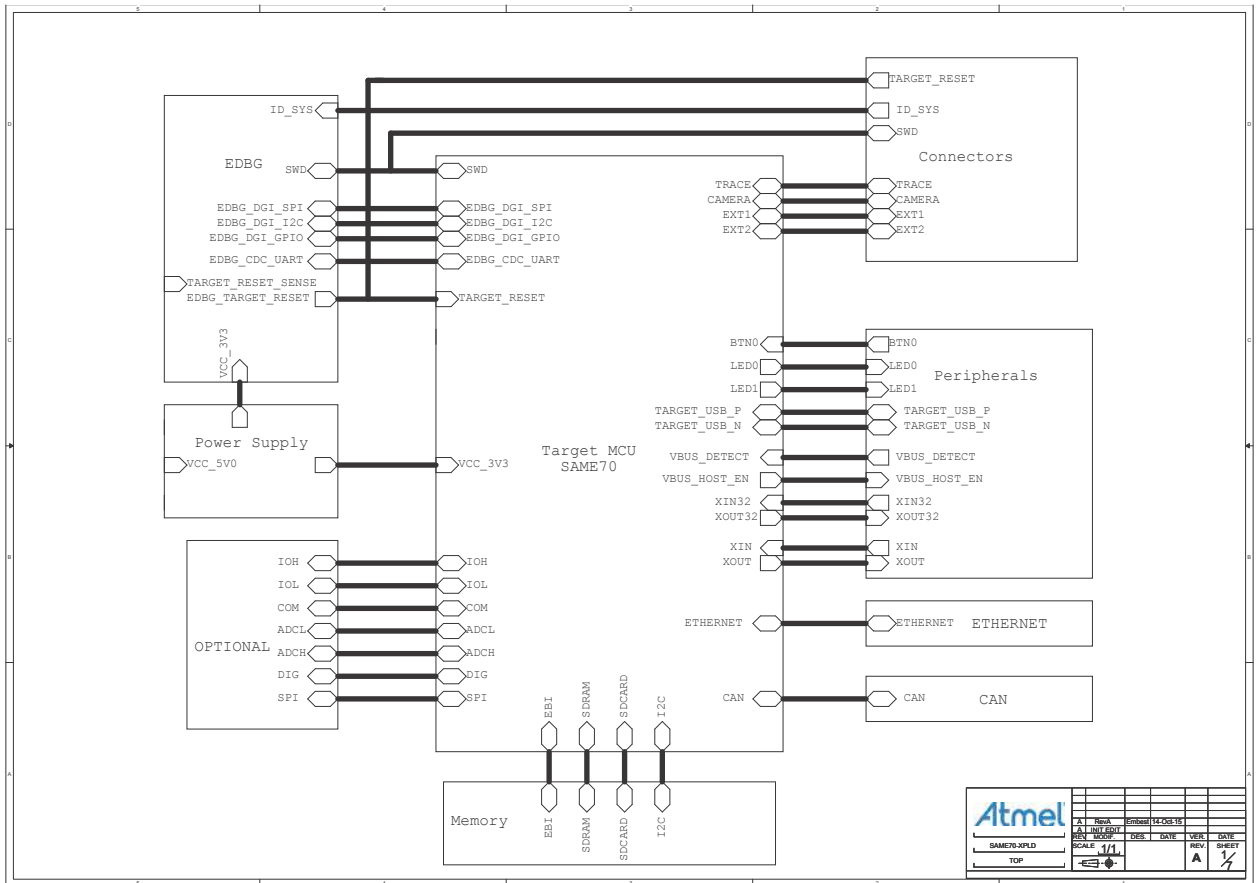

Figure 5-2 SAM E70 Device, Crystals and USB Device interface

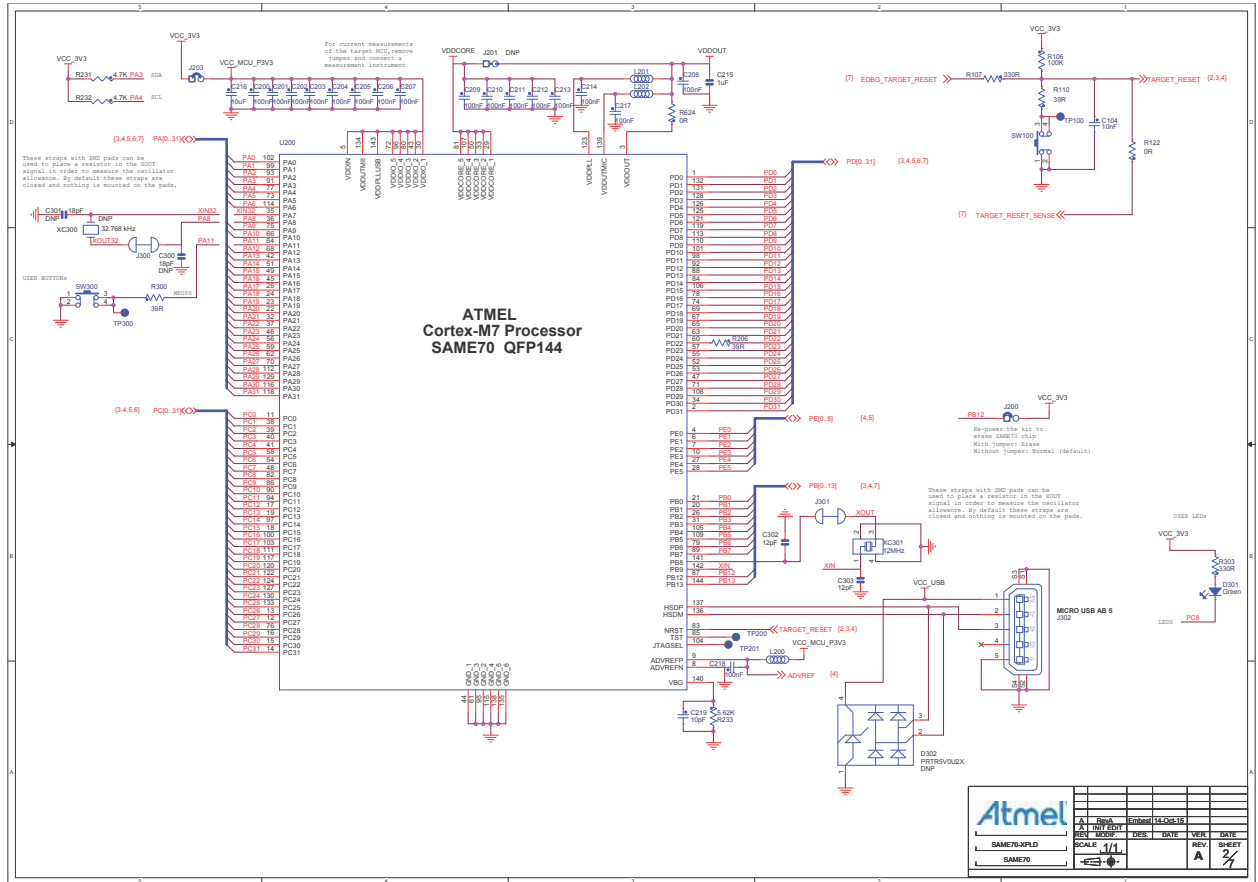
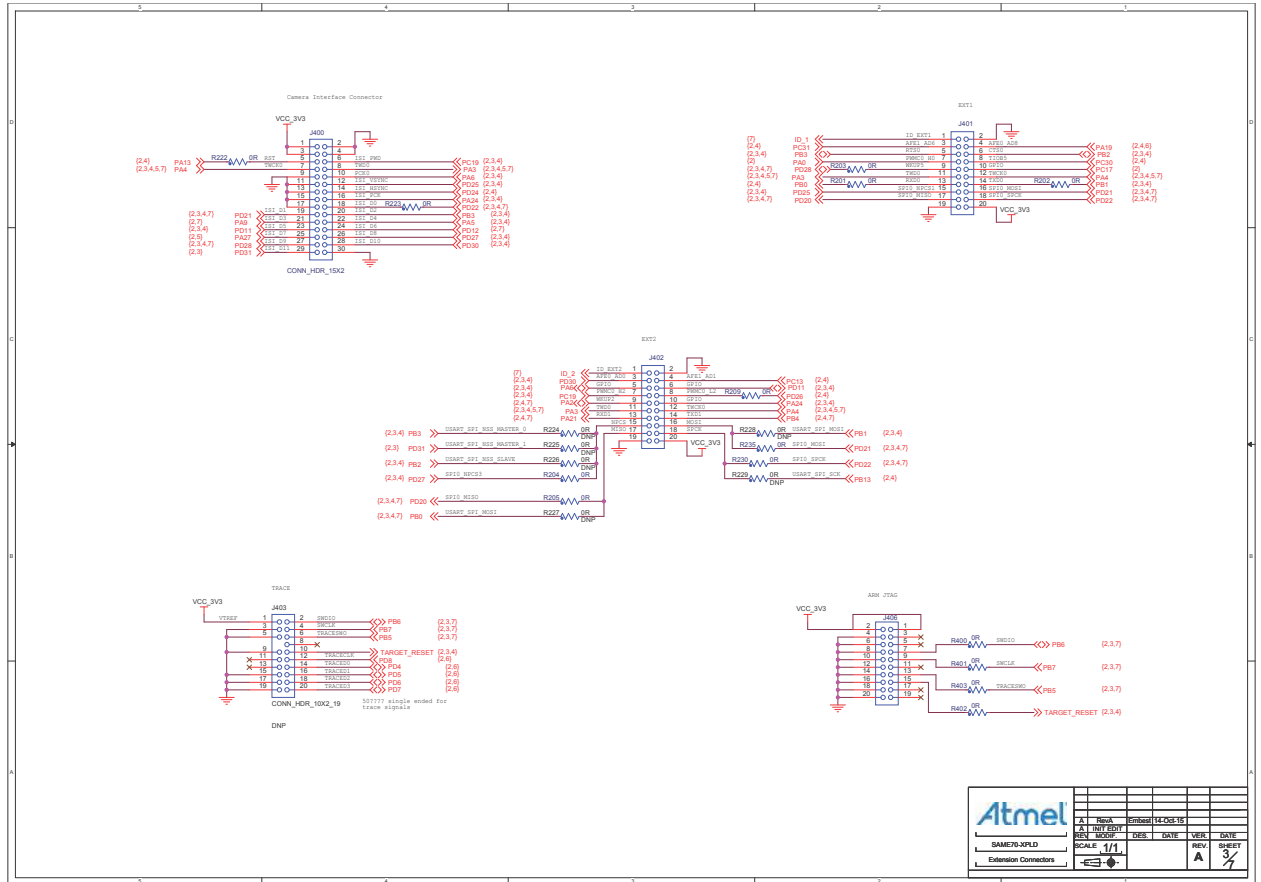
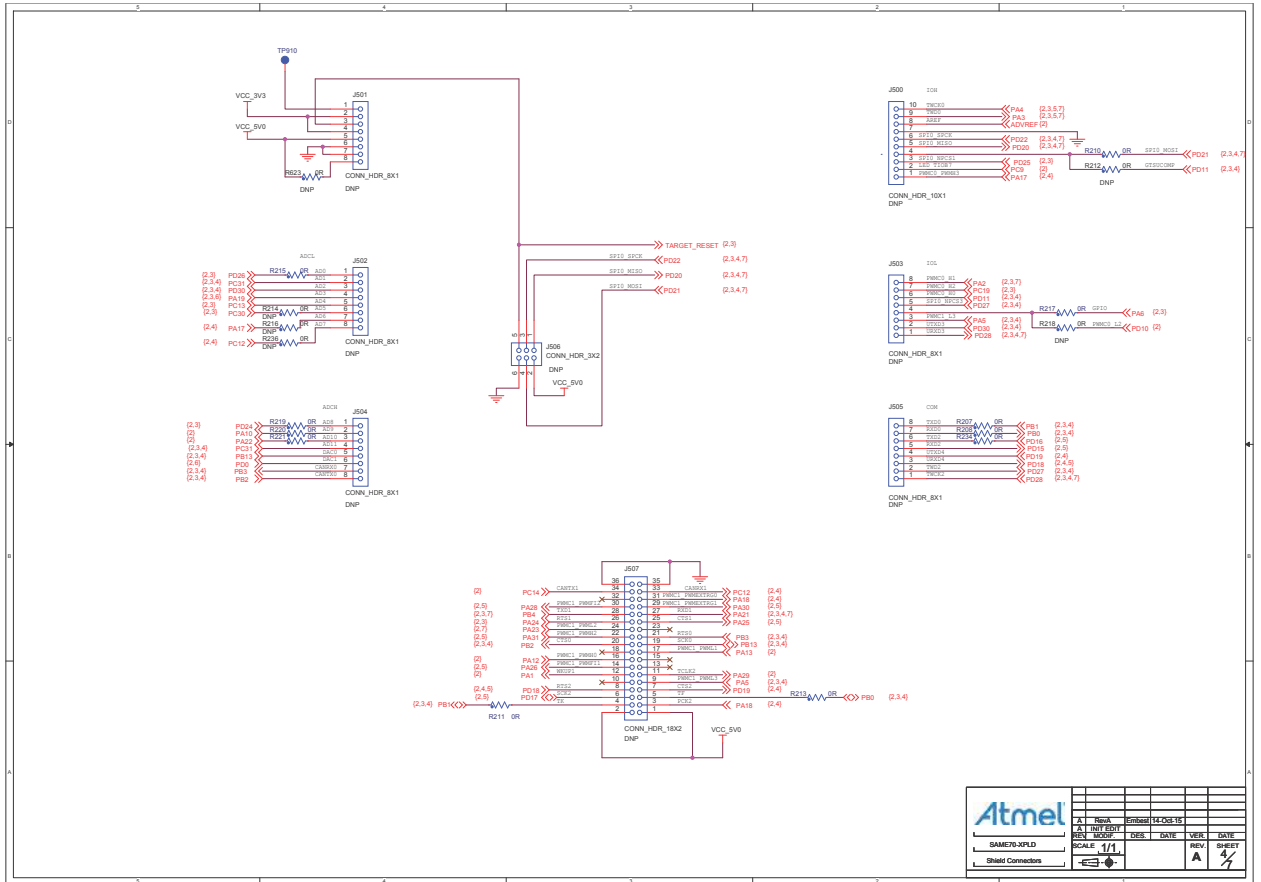

Figure 5-3 Atmel XPRO Extended Connectors, Debug and Camera Interface Connectors



Atmel		Rev	Emitted	14	06	15
A	Rev	Emitted	14	06	15	
SAME70-XPLD						
Extension Connectors		SCALE	1/1	DES	DATE	VER
		REV	A	DATE	3/7	

Figure 5-4 Arduino R3 Extended Connectors



Atmel					
A	Rev	Emitted	14	DEC	15
SAME70-XPLD					
SCALE	1/1	DES		VER	SHEET
Shield Connectors				A	4/7

Figure 5-5 Memories and Power

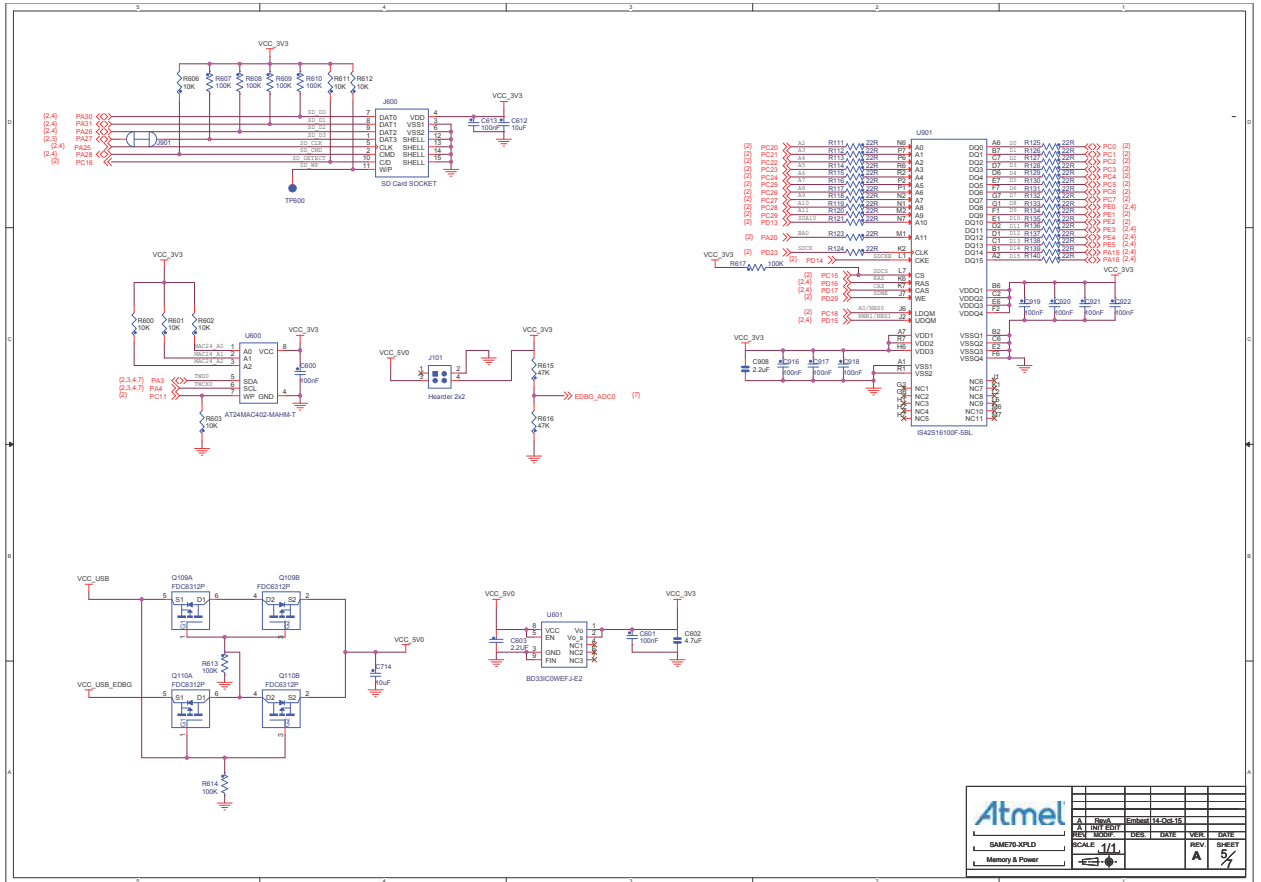

Atmel		REV	DATE
A	REV	14-Oct-15	
REV	DATE	REV	DATE
SAME70-XPLD	SCALE	A	5/7
Memory & Power			

Figure 5-6 Ethernet 10/100

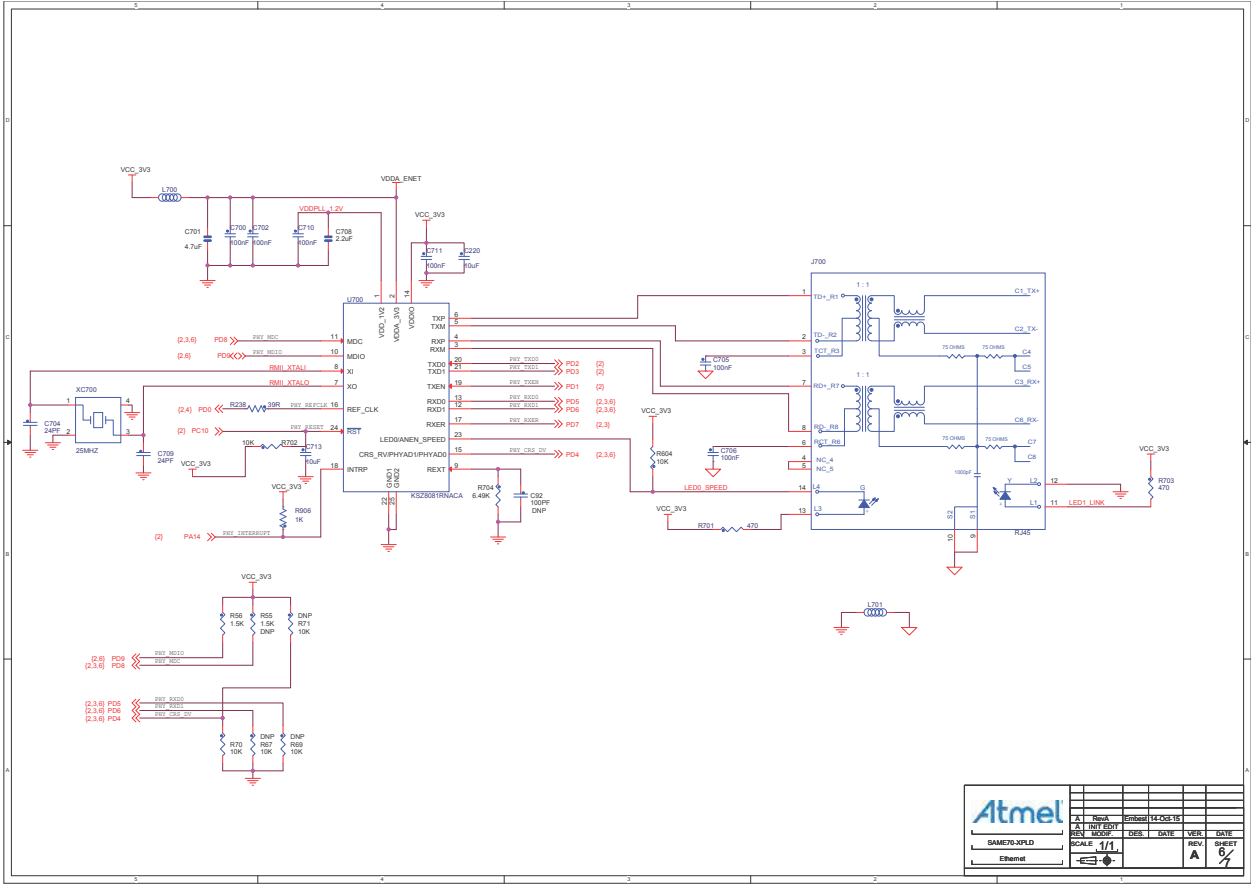

Atmel		REV	DATE	VER	DATE
A	INIT	06/21/11	1.0	1.0	12/2011
A	REV	06/21/11	1.1	A	6/7
SCALE: 1/1					
Ethernet					

Figure 5-7 EDBG Interface

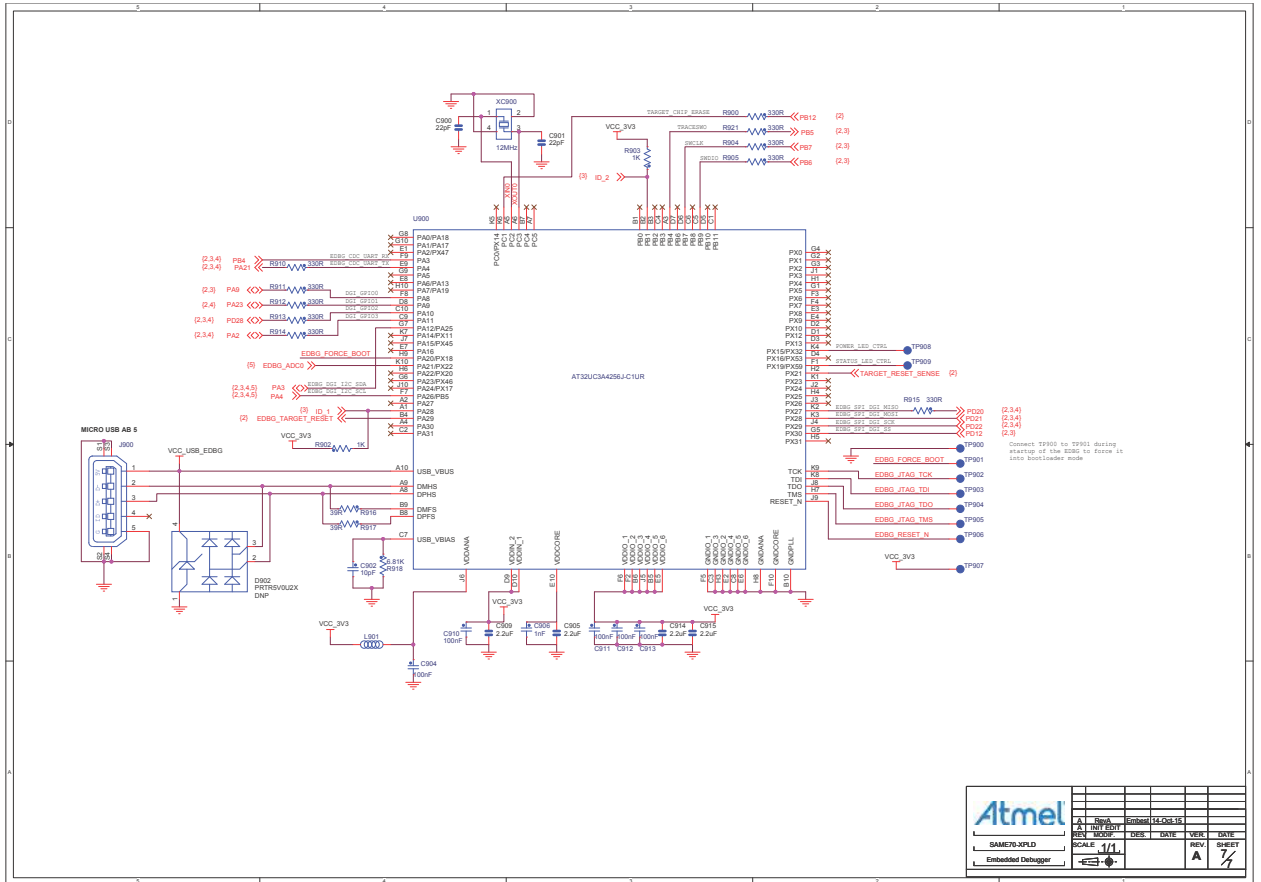

Atmel					
REV	A	DATE	14-Oct-15	DESIGNER	
SCALE	1/1	DATE		REV	
SHEET	A	DATE		REV	
SHEET 7/7					

6. Board Layout

This section contains the following layouts:

- Top Component Placement with Silkscreen
- Bottom Component Placement with Silkscreen
- Top Signals Layer
- Layer 2: Ground
- Layer 3: Power Planes
- Bottom Signals Layer

Figure 6-1 Top Component Placement with Silkscreen

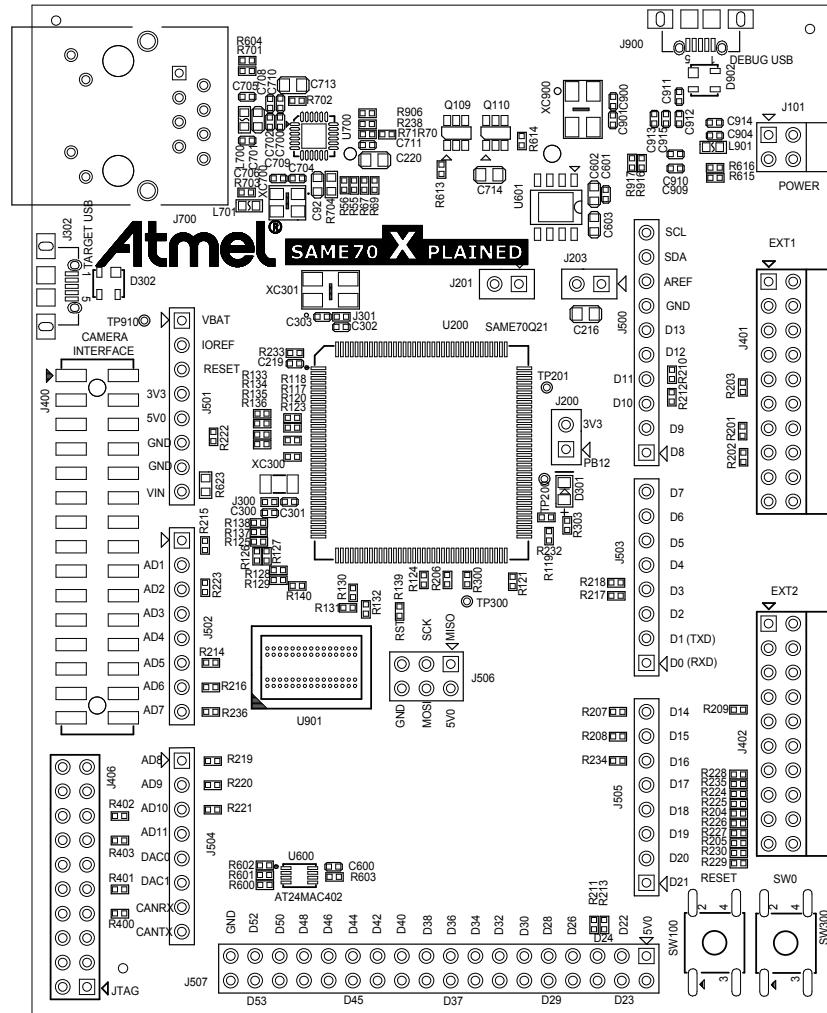

Figure 6-2 Bottom Component Placement with Silkscreen

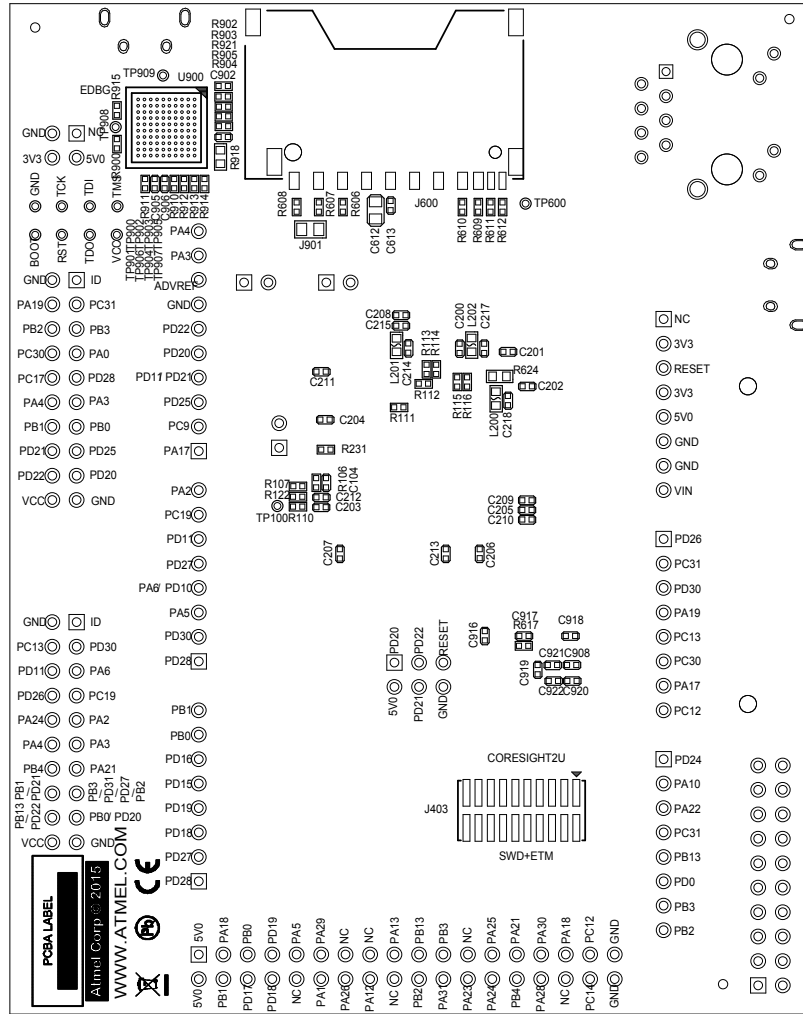

Figure 6-3 Top Signals Layer

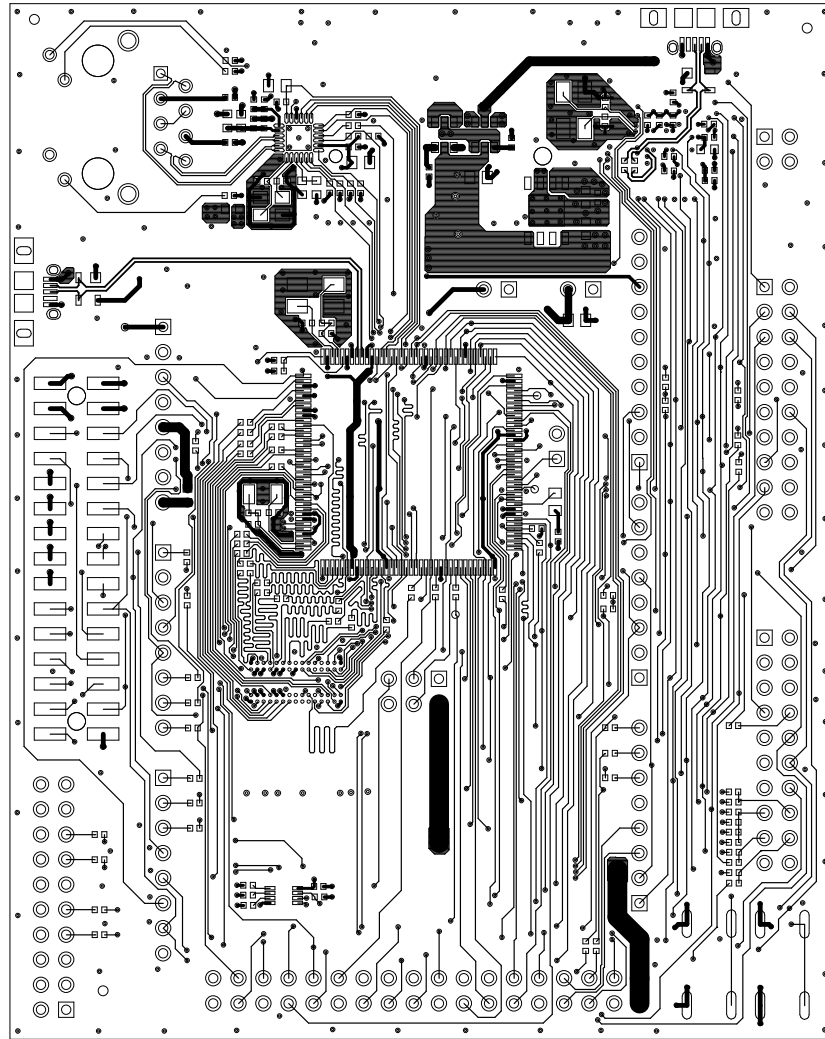

Figure 6-4 Layer 2: Ground

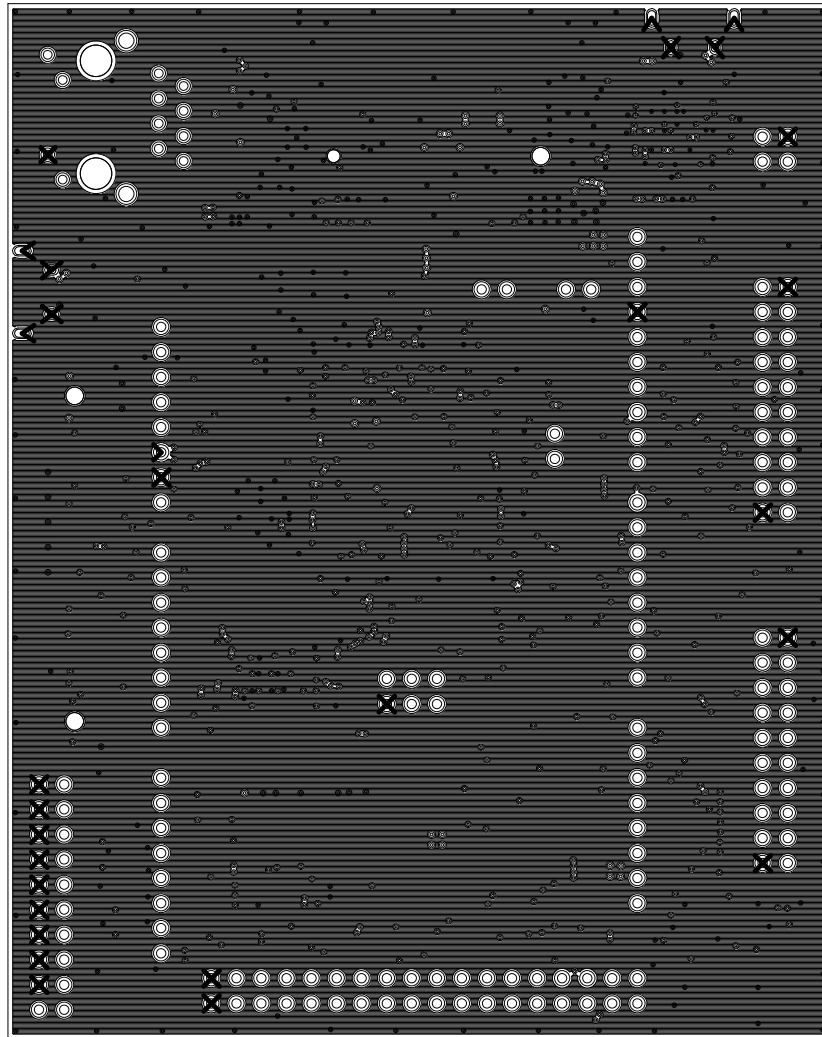

Figure 6-5 Layer 3: Power Planes

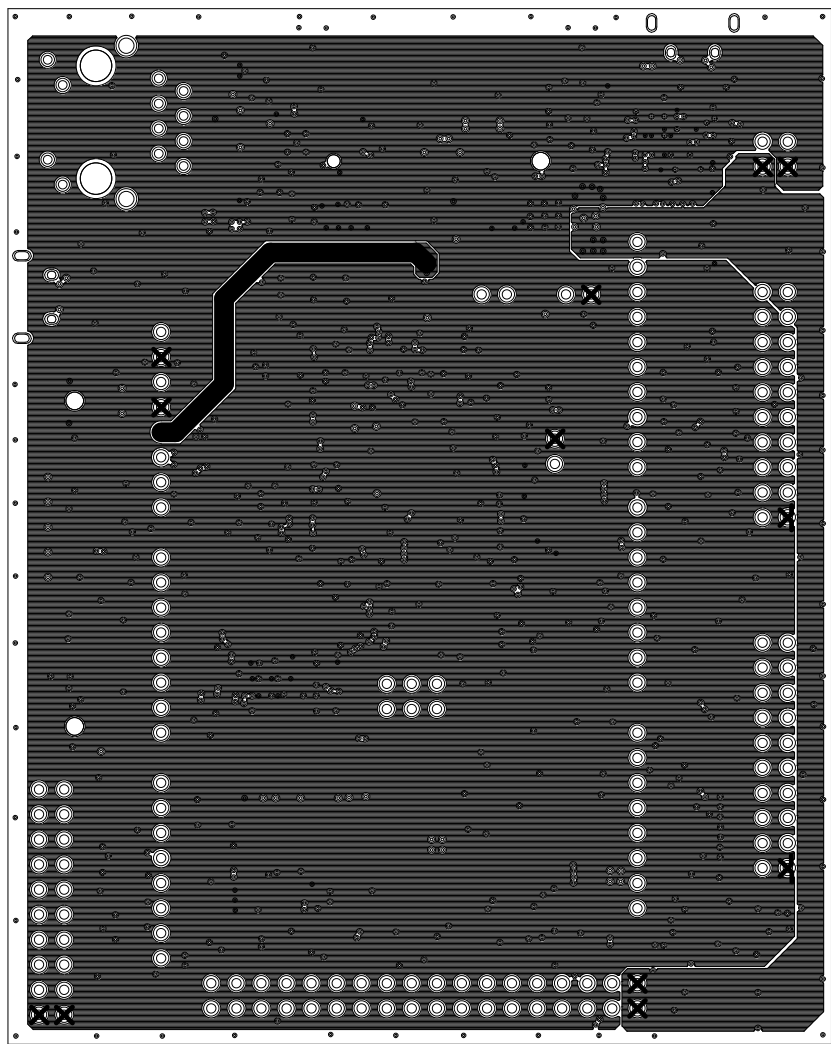
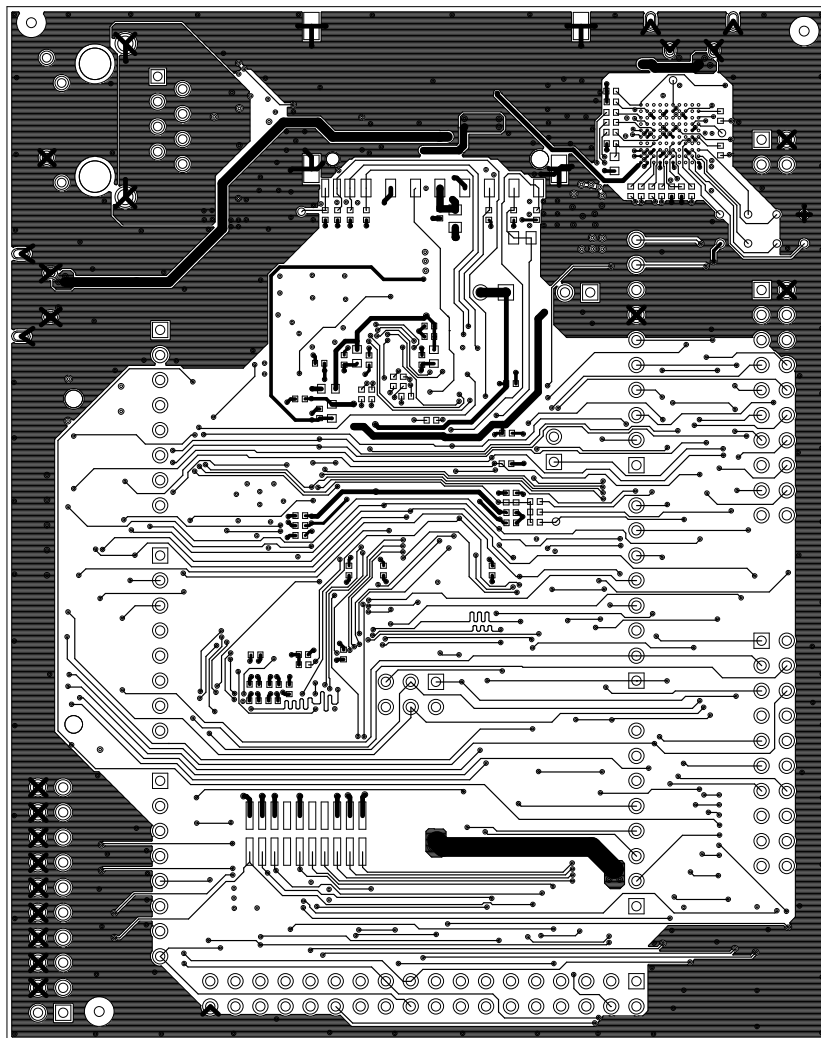

Figure 6-6 Bottom Signals Layer



7. Evaluation Board/kit Important Notice

This evaluation board/kit is intended for use for **FURTHER ENGINEERING, DEVELOPMENT, DEMONSTRATION, OR EVALUATION PURPOSES ONLY**. It is not a finished product and may not (yet) comply with some or any technical or legal requirements that are applicable to finished products, including, without limitation, directives regarding electromagnetic compatibility, recycling (WEEE), FCC, CE or UL (except as may be otherwise noted on the board/kit). Atmel supplied this board/kit "AS IS," without any warranties, with all faults, at the buyer's and further users' sole risk. The user assumes all responsibility and liability for proper and safe handling of the goods. Further, the user indemnifies Atmel from all claims arising from the handling or use of the goods. Due to the open construction of the product, it is the user's responsibility to take any and all appropriate precautions with regard to electrostatic discharge and any other technical or legal concerns.

EXCEPT TO THE EXTENT OF THE INDEMNITY SET FORTH ABOVE, NEITHER USER NOR ATMEL SHALL BE LIABLE TO EACH OTHER FOR ANY INDIRECT, SPECIAL, INCIDENTAL, OR CONSEQUENTIAL DAMAGES.

No license is granted under any patent right or other intellectual property right of Atmel covering or relating to any machine, process, or combination in which such Atmel products or services might be or are used.

Mailing Address:

Atmel Corporation
1600 Technology Drive
San Jose, CA 95110
USA



Atmel Corporation 1600 Technology Drive, San Jose, CA 95110 USA **T:** (+1)(408) 441.0311 **F:** (+1)(408) 436.4200 | **www.atmel.com**

© 2015 Atmel Corporation. / Rev.: Atmel-44050A-SAME70-XPLD_User Guide-12/2015

Atmel®, Atmel logo and combinations thereof, Enabling Unlimited Possibilities®, and others are registered trademarks or trademarks of Atmel Corporation in U.S. and other countries. ARM®, ARM Connected® logo, and others are the registered trademarks or trademarks of ARM Ltd. Other terms and product names may be trademarks of others.

DISCLAIMER: The information in this document is provided in connection with Atmel products. No license, express or implied, by estoppel or otherwise, to any intellectual property right is granted by this document or in connection with the sale of Atmel products. EXCEPT AS SET FORTH IN THE ATMEL TERMS AND CONDITIONS OF SALES LOCATED ON THE ATMEL WEBSITE, ATMEL ASSUMES NO LIABILITY WHATSOEVER AND DISCLAIMS ANY EXPRESS, IMPLIED OR STATUTORY WARRANTY RELATING TO ITS PRODUCTS INCLUDING, BUT NOT LIMITED TO, THE IMPLIED WARRANTY OF MERCHANTABILITY, FITNESS FOR A PARTICULAR PURPOSE, OR NON-INFRINGEMENT. IN NO EVENT SHALL ATMEL BE LIABLE FOR ANY DIRECT, INDIRECT, CONSEQUENTIAL, PUNITIVE, SPECIAL OR INCIDENTAL DAMAGES (INCLUDING, WITHOUT LIMITATION, DAMAGES FOR LOSS AND PROFITS, BUSINESS INTERRUPTION, OR LOSS OF INFORMATION) ARISING OUT OF THE USE OR INABILITY TO USE THIS DOCUMENT, EVEN IF ATMEL HAS BEEN ADVISED OF THE POSSIBILITY OF SUCH DAMAGES. Atmel makes no representations or warranties with respect to the accuracy or completeness of the contents of this document and reserves the right to make changes to specifications and products descriptions at any time without notice. Atmel does not make any commitment to update the information contained herein. Unless specifically provided otherwise, Atmel products are not suitable for, and shall not be used in, automotive applications. Atmel products are not intended, authorized, or warranted for use as components in applications intended to support or sustain life.

SAFETY-CRITICAL, MILITARY, AND AUTOMOTIVE APPLICATIONS DISCLAIMER: Atmel products are not designed for and will not be used in connection with any applications where the failure of such products would reasonably be expected to result in significant personal injury or death ("Safety-Critical Applications") without an Atmel officer's specific written consent. Safety-Critical Applications include, without limitation, life support devices and systems, equipment or systems for the operation of nuclear facilities and weapons systems. Atmel products are not designed nor intended for use in military or aerospace applications or environments unless specifically designated by Atmel as military-grade. Atmel products are not designed nor intended for use in automotive applications unless specifically designated by Atmel as automotive-grade.