



HC49US SMD Crystals

■ Holder Type: SG

Frequency Range:

3.01MHz to 100.00MHz

Features:

- High Reliability & Low Cost Unit
- Tight Stability & Extended Temperature Available
- Lead-free Type
- For automotive applications, please contact our sales representative



SG

Actual Size



SG



QUARTZ
CRYSTALS

■ Standard Specifications

Item	Value
Frequency Range	3.01 to 100.00 MHz
Frequency Tolerance	±30ppm (tighter tolerance also available)
Frequency Tolerance over Temperature range	±50ppm (tighter tolerance also available)
Operating Temperature Range	-10 °C to +60 °C (other operating range also available)
Operable Temperature Range	-40 °C to +85 °C
Equivalent Series Resistance (ESR)	Please refer to the ESR Table
Drive Level	50µW Typ. (300µW Max.)
Load Capacitance	12pF (3pF, 4.5pF, 6pF and series also available)
Ageing	±5ppm/year

■ ESR Table

Frequency Range (MHz)	Mode	Standard ESR (Ohm)
3.01 to 3.5	AT Cut Fund.	300
3.5 to 4.0	AT Cut Fund.	150
4.0 to 4.5	AT Cut Fund.	130
4.5 to 5.0	AT Cut Fund.	110
5.0 to 6.0	AT Cut Fund.	80
6.0 to 7.0	AT Cut Fund.	60
7.0 to 10.0	AT Cut Fund.	50
10.0 to 13.0	AT Cut Fund.	40
13.0 to 50.0	AT Cut Fund.	30
27.0 to 100.0	BT Cut	40
26.0 to 100.0	3rd Overtone	100

Note:

1. Manufacturer reserves the right to change the specification and content of this product for improvement without notification.
2. Custom specification is welcome. Please contact our sales representative for further details.
3. If the crystal is intended for applications which have direct impact on human life and properties, and require a high degree of reliability and safety concerns, customers must provide full information such as but not limit to the application, electrical and reliability specification at the inquiry beginning stage.
4. Customers have to agree to the "Guideline for handling crystal units" and "Standard Terms and Condition of Sales" which is printed this catalog before placing orders to our company or our distributors. There are also unpredictable factors such as applied condition, oscillation margin and etc and customers must check them beforehand. In case of queries, please do not fail to send inquiry to our company before ordering.

Ver.1.2

<https://www.hongkongcrystal.com>

Email: inquiry@hongkongcrystal.com

Tel: +852 35112388 Fax: +852-35112420



■ Dimensions (mm) and Solder Pad Layout (mm)

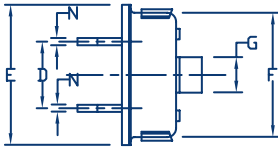

TOP VIEW

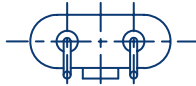

SIDE VIEW

SMD CRYSTAL	
ITEM	DIMENSION
A	9.80 Max.
B	2.52 ±0.3
C	5.08 Max.
D	4.88 ±0.5
E	11.05 Max.
F	10.0 ±0.2
G	3.0 ±0.1
H	3.3 ±0.2
J	5.3 Max.
K	1.5 ±0.2
L	0.2 ±0.1
M	1.5 ±0.2
N	0.45 ±0.05

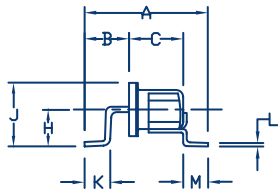

FRONT VIEW

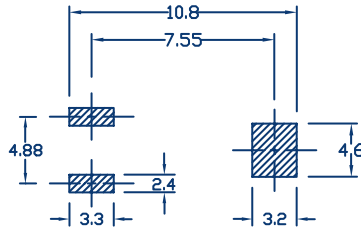

RECOMMENDED LAND PATTERN

MARKING INFORMATION



XXXXXX = CRYSTAL FREQUENCY
YYYYYY - 2-7 DIGITS TRACEABILITY CODE

■ Tape & Reel (mm)

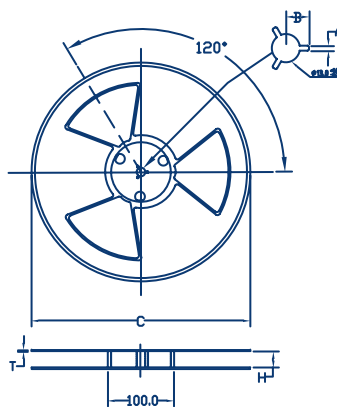
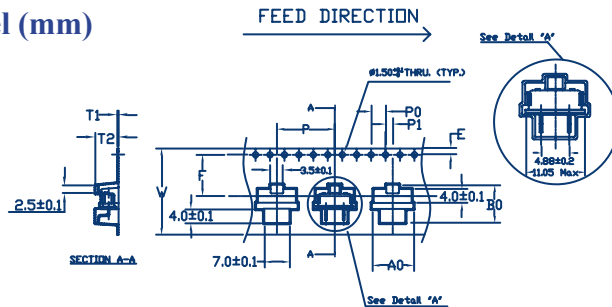

MATERIAL: BLACK ANTI-STATIC POLYSTYRENE
MATERIAL THICKNESS: 0.4MM

SG	
PART NO.	48065004
W	24.0±0.3
P	16.0±0.1
P0	4.0±0.1
P1	2.0±0.1
Ao	11.8±0.1
E	1.75±0.1
F	11.5±0.1
B0	11.4±0.1
T1	0.5±0.05
T2	6.0±0.1
PART NO.	48060006
C	∅330±1
A	2.3±0.3
B	10.75±0.2
H	24.5±0.2
T	2.3±0.3
QTY.	500PCS/R

QUARTZ
CRYSTALS