



# KSZ8061RNB/RND

---

## 10BASE-T/100BASE-TX Physical Layer Transceiver

---

### Highlights

- Single-Chip Ethernet Physical Layer Transceiver (PHY)
- Quiet-Wire<sup>®</sup> Technology to Reduce Line Emissions and Enhance Immunity
- Ultra-Deep Sleep Standby Mode
- AEC-Q100 Grade 2 Automotive Qualified

### Target Applications

- Industrial Control
- Vehicle On-Board Diagnostics (OBD)
- Automotive Gateways
- Camera and Sensor Networking
- Infotainment

### Key Benefits

- Quiet-Wire Programmable EMI Filter
- RMII Interface with MDC/MDIO Management Interface for Register Configuration
- On-Chip Termination Resistors for Differential Pairs
- LinkMD<sup>®</sup>+ Receive Signal Quality Indicator
- Fast Start-Up and Link
- Ultra-Deep Sleep Standby Mode; CPU or Signal Detect Activated
- Loopback Modes for Diagnostics
- Programmable Interrupt Output

## TO OUR VALUED CUSTOMERS

It is our intention to provide our valued customers with the best documentation possible to ensure successful use of your Microchip products. To this end, we will continue to improve our publications to better suit your needs. Our publications will be refined and enhanced as new volumes and updates are introduced.

If you have any questions or comments regarding this publication, please contact the Marketing Communications Department via E-mail at [docerrors@microchip.com](mailto:docerrors@microchip.com). We welcome your feedback.

### Most Current Data Sheet

To obtain the most up-to-date version of this data sheet, please register at our Worldwide Web site at:

<http://www.microchip.com>

You can determine the version of a data sheet by examining its literature number found on the bottom outside corner of any page. The last character of the literature number is the version number, (e.g., DS30000000A is version A of document DS30000000).

### Errata

An errata sheet, describing minor operational differences from the data sheet and recommended workarounds, may exist for current devices. As device/documentation issues become known to us, we will publish an errata sheet. The errata will specify the revision of silicon and revision of document to which it applies.

To determine if an errata sheet exists for a particular device, please check with one of the following:

- Microchip's Worldwide Web site; <http://www.microchip.com>
- Your local Microchip sales office (see last page)

When contacting a sales office, please specify which device, revision of silicon and data sheet (include -literature number) you are using.

### Customer Notification System

Register on our web site at [www.microchip.com](http://www.microchip.com) to receive the most current information on all of our products.

## Table of Contents

1.0 Introduction .....	4
2.0 Pin Description and Configuration .....	5
3.0 Functional Description .....	9
4.0 Register Map .....	25
5.0 Operational Characteristics .....	38
6.0 Electrical Characteristics .....	39
7.0 Timing Diagrams .....	42
8.0 Reset Circuit .....	46
9.0 Reference Clock Connection and Selection - KSZ8061RNB .....	47
10.0 Reference Clock Connection - KSZ8061RND .....	48
11.0 Magnetic – Connection and Selection .....	49
12.0 Package Outlines .....	50
Appendix A: Data Sheet Revision History .....	52
The Microchip Web Site .....	54
Customer Change Notification Service .....	54
Customer Support .....	54
Product Identification System .....	55

# KSZ8061RNB/RND

## 1.0 INTRODUCTION

### 1.1 General Description

The KSZ8061RNB/RND is a single-chip 10BASE-T/100BASE-TX Ethernet physical layer transceiver for transmission and reception of data over an unshielded twisted pair (UTP) cable.

The KSZ8061RNB/RND features Quiet-Wire<sup>®</sup> internal filtering to reduce line emissions. It is ideal for applications, such as automotive or industrial networks, where stringent radiated emission limits must be met. Quiet-Wire can utilize low-cost unshielded cable, where previously only shielded cable solutions were possible. The KSZ8061RNB/RND also features enhanced immunity to environmental EM noise.

The KSZ8061RNB/RND features a Reduced Media Independent Interface (RMII) for direct connection with RMII-compliant Ethernet MAC processors and switches.

The KSZ8061RNB generates a 50-MHz RMII reference clock for use by the connected MAC device. In contrast, the KSZ8061RND receives the 50-MHz RMII reference clock as an input.

The KSZ8061RNB/RND meets Automotive AEC-Q100 and EMC requirements, with an extended temperature range of -40°C to +105°C. It is supplied in 32-pin, 5 mm × 5 mm QFN and WQFN packages.

The KSZ8061MNX and KSZ8061MNG devices have an MII interface and are described in a separate data sheet.

**FIGURE 1-1: SYSTEM BLOCK DIAGRAM**

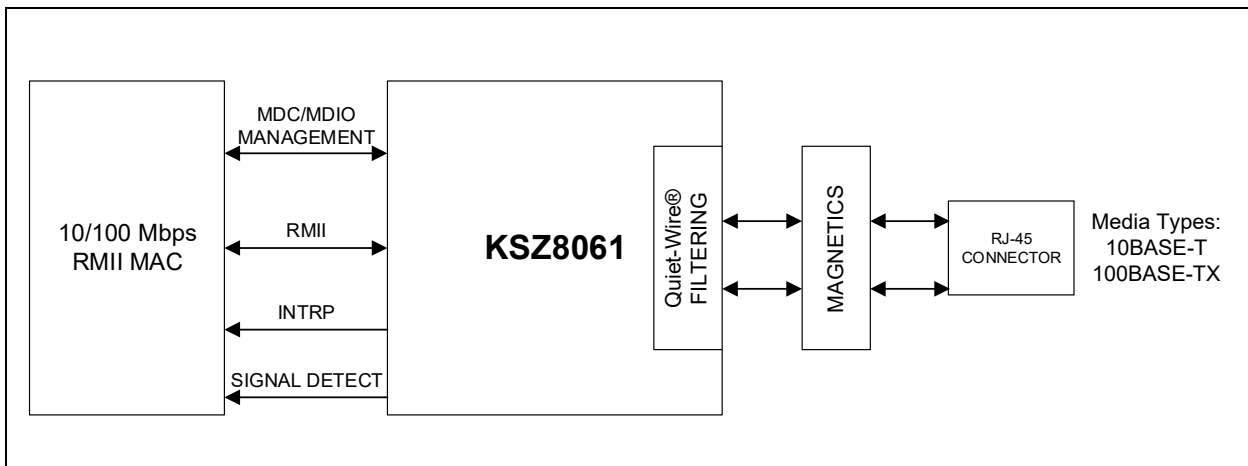

## 2.0 PIN DESCRIPTION AND CONFIGURATION

FIGURE 2-1: 32-QFN PIN ASSIGNMENT (TOP VIEW)

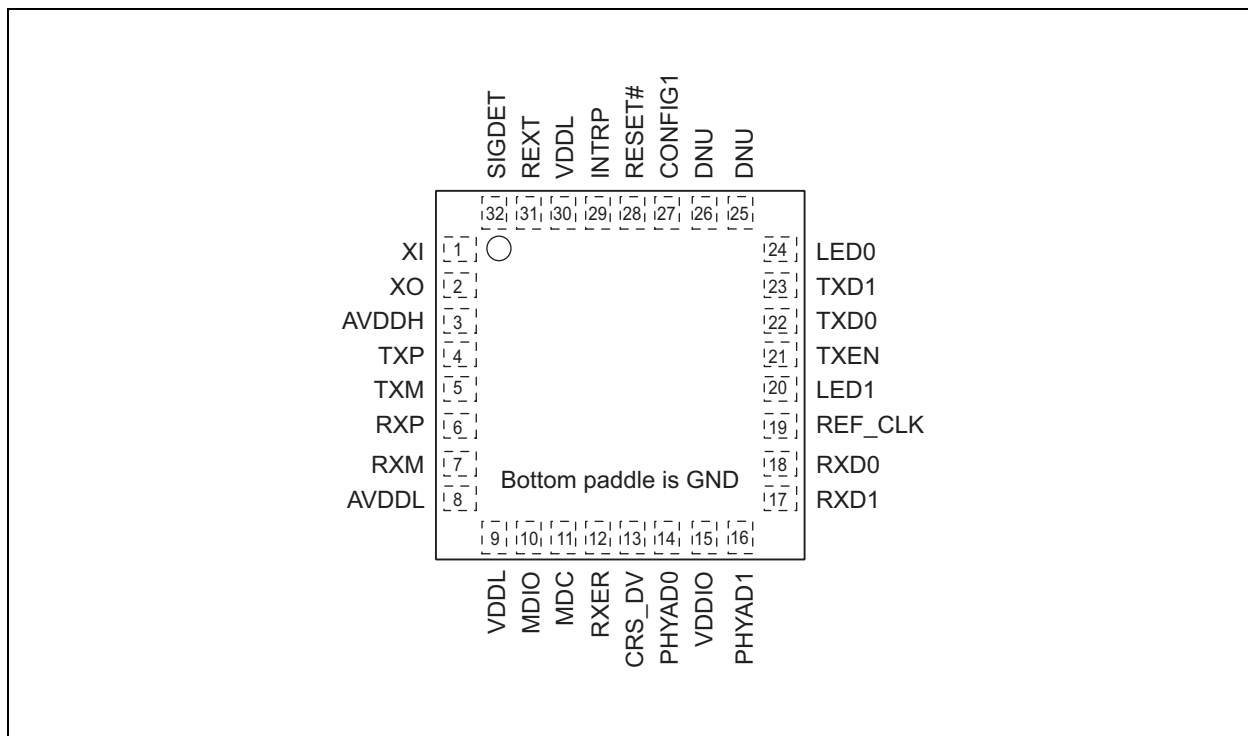

TABLE 2-1: SIGNALS

Pin Number	Name	Buffer Type (Note 2-1)	Description
1	XI	I	KSZ8061RNB: 25-MHz Crystal/Oscillator/External Clock Input. This input references the AVDDH power supply.
			KSZ8061RND: 50-MHz RMI Reference Clock Input. This input references the AVDDH power supply.
2	XO	O	KSZ8061RNB: Crystal feedback for 25-MHz crystal. This pin is a no connect if oscillator or external clock source is used.
			KSZ8061RND: This pin is unused. Leave it unconnected.
3	AVDDH	PWR	3.3V Supply for analog TX drivers and XI/XO oscillator circuit.
4	TXP	I/O	Physical transmit or receive signal (+ differential) Transmit when in MDI mode; Receive when in MDI-X mode.
5	TXM	I/O	Physical transmit or receive signal (- differential) Transmit when in MDI mode; Receive when in MDI-X mode.
6	RXP	I/O	Physical receive or transmit signal (+ differential) Receive when in MDI mode; Transmit when in MDI-X mode.
7	RXM	I/O	Physical receive or transmit signal (- differential) Receive when in MDI mode; Transmit when in MDI-X mode.
8	AVDDL	PWR	1.2V (nominal) supply for analog core
9	VDDL	PWR	1.2V (nominal) supply for digital core
10	MDIO	IPU/OPU	Management Interface (MIIM) Data I/O This pin has a weak pull-up, is open-drain like, and requires an external 1-kΩ pull-up resistor.

# KSZ8061RNB/RND

**TABLE 2-1: SIGNALS (CONTINUED)**

Pin Number	Name	Buffer Type (Note 2-1)	Description
11	MDC	IPU	Management Interface (MIIM) Clock Input This clock pin is synchronous to the MDIO data pin.
12	RXER / QWF	IPD/O	RMII Receive Error Output Config mode: The pull-up or pull-down value is latched as QWF at the deassertion of reset. See <a href="#">Table 2-2, "Strap-in Options"</a> for details.
13	CRS_DV / CONFIG2	IPD/O	RMII Carrier Sense/Receive Data Valid Output Config mode: The pull-up or pull-down value is latched as CONFIG2 at the deassertion of reset. See <a href="#">Table 2-2, "Strap-in Options"</a> for details.
14	PHYAD0	IPU/O	No function during normal operation Config mode: The pull-up or pull-down value is latched as PHYADDR[0] at the deassertion of reset. See <a href="#">Table 2-2, "Strap-in Options"</a> for details.
15	VDDIO	PWR	3.3V or 2.5V supply for digital I/O
16	PHYAD1	IPD/O	No function during normal operation Config mode: The pull-up or pull-down value is latched as PHYADDR[1] at the deassertion of reset. See <a href="#">Table 2-2, "Strap-in Options"</a> for details.
17	RXD1 / PHYAD2	IPD/O	RMII Receive Data Output[1] ( <a href="#">Note 2-2</a> ) Config mode: The pull-up or pull-down value is latched as PHYADDR[2] at the deassertion of reset. See <a href="#">Table 2-2, "Strap-in Options"</a> for details.
18	RXD0 / AUTONEG	IPU/O	RMII Receive Data Output[0] ( <a href="#">Note 2-2</a> ) Config mode: The pull-up or pull-down value is latched as AUTONEG at the deassertion of reset. See <a href="#">Table 2-2, "Strap-in Options"</a> for details.
19	REF_CLK / CONFIG0	IPD/O	KSZ8061RNB: RMII 50-MHz Reference Clock Output to the MAC Config mode: The pull-up or pull-down value is latched as CONFIG0 at the deassertion of reset. See <a href="#">Table 2-2, "Strap-in Options"</a> for details.
			KSZ8061RND: This pin is unused during normal operation. Leave it unconnected except as required for Config mode. Config mode: The pull-up or pull-down value is latched as CONFIG0 at the deassertion of reset. See <a href="#">Table 2-2, "Strap-in Options"</a> for details.
20	LED1	O	LED1 Output Active low. Its function is programmable; by default it indicates link speed.
21	TXEN	I	PMII Transmit Enable Input
22	TXD0	I	RMII Transmit Data Input[0] ( <a href="#">Note 2-3</a> )
23	TXD1	I	RMII Transmit Data Input[1] ( <a href="#">Note 2-3</a> )
24	LED0	IPD/O	LED0 Output Active low. Its function is programmable; by default it indicates link/activity.
25	DNU	I	Do Not Use. This unused input must be pulled to a logic-low level.
26	DNU	I	Do Not Use. This unused input should be pulled to a logic-low level.
27	CONFIG1	IPD/O	No function during normal operation Config mode: The pull-up or pull-down value is latched as CONFIG1 at the deassertion of reset. See <a href="#">Table 2-2, "Strap-in Options"</a> for details.
28	RESET#	IPU	Chip Reset (active-low)
29	INTRP / NAND_TREE#	IPU/O	Programmable Interrupt Output (active-low [default] or active-high) This pin has a weak pull-up, is open-drain like, and requires an external 1.0-kΩ pull-up resistor. Config mode: The pull-up or pull-down value is latched as NAND_Tree# at the deassertion of reset. See <a href="#">Table 2-2, "Strap-in Options"</a> for details.
30	VDDL	PWR	1.2V (nominal) supply for digital (and analog)

**TABLE 2-1: SIGNALS (CONTINUED)**

Pin Number	Name	Buffer Type (Note 2-1)	Description
31	REXT	I	Set PHY transmit output current. Connect a 6.04 kΩ 1% resistor from this pin to ground.
32	SIGDET	O	Signal Detect, active-high
Bottom Paddle	GND	GND	Ground. Bottom paddle.

- Note 2-1** Pwr = Power supply  
 Gnd = Ground  
 I = Input  
 O = Output  
 I/O = Bi-directional  
 Ipu = Input with internal pull-up (see [Electrical Characteristics](#) for value)  
 Ipd = Input with internal pull-down (see [Electrical Characteristics](#) for value)  
 Ipu/O = Input with internal pull-up (see [Electrical Characteristics](#) for value) during power-up or reset; output pin otherwise.  
 Ipd/O = Input with internal pull-down (see [Electrical Characteristics](#) for value) during power-up or reset; output pin otherwise.  
 Ipu/Opu = Input and output with internal pull-up (see [Electrical Characteristics](#) for value)
- Note 2-2** RMII mode: The RXD[3:0] bits are synchronous with RXC. When RXDV is asserted, RXD[3:0] presents valid data to the MAC device.
- Note 2-3** RMII mode: The TXD[3:0] bits are synchronous with TXC. When TXEN is asserted, TXD[3:0] accepts valid data from the MAC device.

# KSZ8061RNB/RND

The strap-in pins are latched at the deassertion of reset. In some systems, the MAC RMI receive input pins may drive high or low during power-up or reset, and consequently cause the PHY strap-in pins on the RMI signals to be latched to the unintended high or low states. In this case, external pull-up or pull-down resistors (4.7 kΩ) should be added on these PHY strap-in pins to ensure the intended values are strapped in correctly.

**TABLE 2-2: STRAP-IN OPTIONS**

Pin Number	Name	Buffer Type (Note 2-4)	Description		
17	RXD1/PHYAD2	IPD/O	The PHY Address is latched at the deassertion of reset and is configurable to any value from 0 to 7. The default PHY Address is 00001. PHY Address bits [4:3] are set to 00 by default.		
16	PHYAD1	IPD/O			
14	PHYAD0	IPU/O			
13	CRS_DV/ CONFIG2	IPD/O	The CONFIG[2:0] strap-in pins are latched at the deassertion of reset.		
			000	Reserved - not used	
27	CONFIG1	IPD/O	001	RMI normal mode	Auto MDI/MDI-X disabled
			010 - 100	Reserved - not used	
			101	RMI Back-to-Back	Auto MDI/MDI-X enabled
19	REF_CLK/ CONFIG0	IPD/O	110	Reserved - not used	
			111	RMI normal mode	Auto MDI/MDI-X enabled
18	RXD0/ AUTONEG	IPU/O	Auto-Negotiation Disable Pull-up (default) = Disable Auto-Negotiation Pull-down = Enable Auto-Negotiation At the deassertion of reset, this pin value is latched into register 0h, bit [12].		
29	INTRP/ NAND_TREE#	IPU/O	NAND Tree mode Pull-up (default) = Disable NAND Tree (normal operation) Pull-down = Enable NAND Tree At the deassertion of reset, this pin value is latched by the chip.		
12	RXER/QWF	IPD/O	Quiet-Wire Filtering Disable Pull-up = Disable Quiet-Wire Filtering Pull-down (default) = Enable Quiet-Wire Filtering At the deassertion of reset, this pin value is latched by the chip.		

**Note 2-4** Ipu/O = Input with internal pull-up during power-up or reset; output pin otherwise. (See the [Electrical Characteristics](#) section for each value.) Ipd/O = Input with internal pull-down (see the [Electrical Characteristics](#) section for each value during power-up/reset; output pin otherwise.



## 3.0 FUNCTIONAL DESCRIPTION

The KSZ8061RNB/RND is an integrated Fast Ethernet transceiver that features Quiet-Wire<sup>®</sup> internal filtering to reduce line emissions. When Quiet-Wire filtering is disabled, it is fully compliant with the IEEE 802.3 Specification. The KSZ8061RNB/RND also has a high noise immunity.

On the copper media side, the KSZ8061RNB/RND supports 10BASE-T and 100BASE-TX for transmission and reception of data over a standard CAT-5 or a similar unshielded twisted pair (UTP) cable, and HP Auto MDI/MDI-X for reliable detection of and correction for straight-through and crossover cables.

On the MAC processor side, the KSZ8061RNB/RND offers the Reduced Media Independent Interface (RMII) for direct connection with RMII-compliant Ethernet MAC processors and switches.

The RMII management bus gives the MAC processor complete access to the KSZ8061RNB/RND control and status registers. Additionally, an interrupt pin eliminates the need for the processor to poll for PHY status change.

Auto-negotiation and Auto MDI/MDIX can be disabled at power-on to significantly reduce initial time to link up.

A signal detect pin (SIGDET) is available to indicate when the link partner is inactive. An option is available for the KSZ8061RNB/RND to automatically enter Ultra-Deep Sleep mode when SIGDET is deasserted. Ultra-Deep Sleep mode may also be entered by command of the MAC processor. Additional low power modes are available.

### 3.1 10BASE-T/100BASE-TX Transceiver

#### 3.1.1 100BASE-TX TRANSMIT

The 100BASE-TX transmit function performs parallel-to-serial conversion, 4B/5B encoding, scrambling, NRZ-to-NRZI conversion, and MLT3 encoding and transmission.

The circuitry starts with a parallel-to-serial conversion, which converts the RMII data from the MAC into a 125-MHz serial bit stream. The data and control stream is then converted into 4B/5B coding and followed by a scrambler. The serialized data is further converted from NRZ-to-NRZI format, and then transmitted in MLT3 current output. The output current is set by a precision external resistor on REXT for the 1:1 transformer ratio.

The output signal has a typical rise or fall time of 4 ns and complies with the ANSI TP-PMD standard regarding amplitude balance, overshoot, and timing jitter. The wave-shaped 10BASE-T output is also incorporated into the 100BASE-TX transmitter.

#### 3.1.2 100BASE-TX RECEIVE

The 100BASE-TX receiver function performs adaptive equalization, DC restoration, MLT3-to-NRZI conversion, data and clock recovery, NRZI-to-NRZ conversion, descrambling, 4B/5B decoding, and serial-to-parallel conversion.

The receiving side starts with the equalization filter to compensate for inter-symbol interference (ISI) over the twisted pair cable. Because the amplitude loss and phase distortion is a function of the cable length, the equalizer must adjust its characteristics to optimize performance. In this design, the variable equalizer makes an initial estimation based on comparisons of incoming signal strength against some known cable characteristics, and then tunes itself for optimization. This is an ongoing process and self-adjusts against environmental changes, such as temperature variations.

Next, the equalized signal goes through a DC restoration and data conversion block. The DC restoration circuit is used to compensate for the effect of baseline wander and to improve the dynamic range. The differential data conversion circuit converts the MLT3 format back to NRZI. The slicing threshold is also adaptive.

The clock recovery circuit extracts the 125-MHz clock from the edges of the NRZI signal. This recovered clock is then used to convert the NRZI signal into the NRZ format. This signal is sent through the descrambler followed by the 4B/5B decoder. Finally, the NRZ serial data is converted to the RMII format and provided as the input data to the MAC.

#### 3.1.3 SCRAMBLER/DE-SCRAMBLER (100BASE-TX ONLY)

The scrambler is used to spread the power spectrum of the transmitted signal to reduce EMI and baseline wander. The descrambler is needed to recover the scrambled signal.

#### 3.1.4 10BASE-T TRANSMIT

The 10BASE-T drivers are incorporated with the 100BASE-TX drivers to allow for transmission using the same magnetic. The drivers perform internal wave-shaping and pre-emphasis, then output 10BASE-T signals with a typical amplitude of 2.5V peak. The 10BASE-T signals have harmonic contents that are at least 27 dB below the fundamental frequency when driven by an all-ones Manchester-encoded signal.

# KSZ8061RNB/RND

---

## 3.1.5 10BASE-T RECEIVE

On the receive side, input buffer and level detecting squelch circuits are employed. A differential input receiver circuit and a PLL performs the decoding function. The Manchester-encoded data stream is separated into clock signal and NRZ data. A squelch circuit rejects signals with levels less than 400 mV or with short pulse widths to prevent noise at the RXP and RXM inputs from falsely triggering the decoder. When the input exceeds the squelch limit, the PLL locks onto the incoming signal and the KSZ8061RNB/RND decodes a data frame. The receive clock is kept active during idle periods in between data reception.

## 3.1.6 PLL CLOCK SYNTHESIZER

The KSZ8061RNB/RND generates all internal clocks and all external clocks for system timing from the clock received at the XI pin. For the KSZ8061RNB, this is an external 25-MHz crystal, oscillator, or reference clock. For the KSZ8061RND, this is the externally supplied RMII 50-MHz reference clock.

## 3.1.7 AUTO-NEGOTIATION

The KSZ8061RNB/RND conforms to the auto-negotiation protocol, defined in Clause 28 of the IEEE 802.3 Specification.

Auto-negotiation allows unshielded twisted pair (UTP) link partners to select the highest common mode of operation.

During auto-negotiation, link partners advertise capabilities across the UTP link to each other, and then compare their own capabilities with those they received from their link partners. The highest speed and duplex setting that is common to the two link partners is selected as the mode of operation.

The following list shows the speed and duplex operation mode from highest to lowest priority:

- Priority 1: 100BASE-TX, full-duplex
- Priority 2: 100BASE-TX, half-duplex
- Priority 3: 10BASE-T, full-duplex
- Priority 4: 10BASE-T, half-duplex

If the KSZ8061RNB/RND is using auto-negotiation, but its link partner is not, then the KSZ8061RNB/RND sets its operating speed by observing the signal at its receiver. This is known as parallel detection, and allows the KSZ8061RNB/RND to establish a link by listening for a fixed signal protocol in the absence of auto-negotiation advertisement protocol. Duplex is set by register 0h, bit [8] because the KSZ8061RNB/RND cannot determine duplex by parallel detection.

If auto-negotiation is disabled, the speed is set by register 0h, bit [13], and the duplex is set by register 0h, bit [8]. The default is 100BASE-TX, full-duplex.

Auto-negotiation is enabled or disabled by hardware pin strapping (AUTONEG) and by software (register 0h, bit [12]). By default, auto-negotiation is disabled after power-up or hardware reset, but it may be enabled by pulling the RXD0 pin low at that time. Afterwards, auto-negotiation can be enabled or disabled by register 0h, bit [12].

When the link is 10BASE-T or the link partner is using auto-negotiation and the Ultra-Deep Sleep mode is used, then the Signal Detect assertion timing delay bit, register 14h bit [1], must be set.

The auto-negotiation link-up process is shown in [Figure 3-1](#).

**FIGURE 3-1: AUTO-NEGOTIATION FLOW CHART**

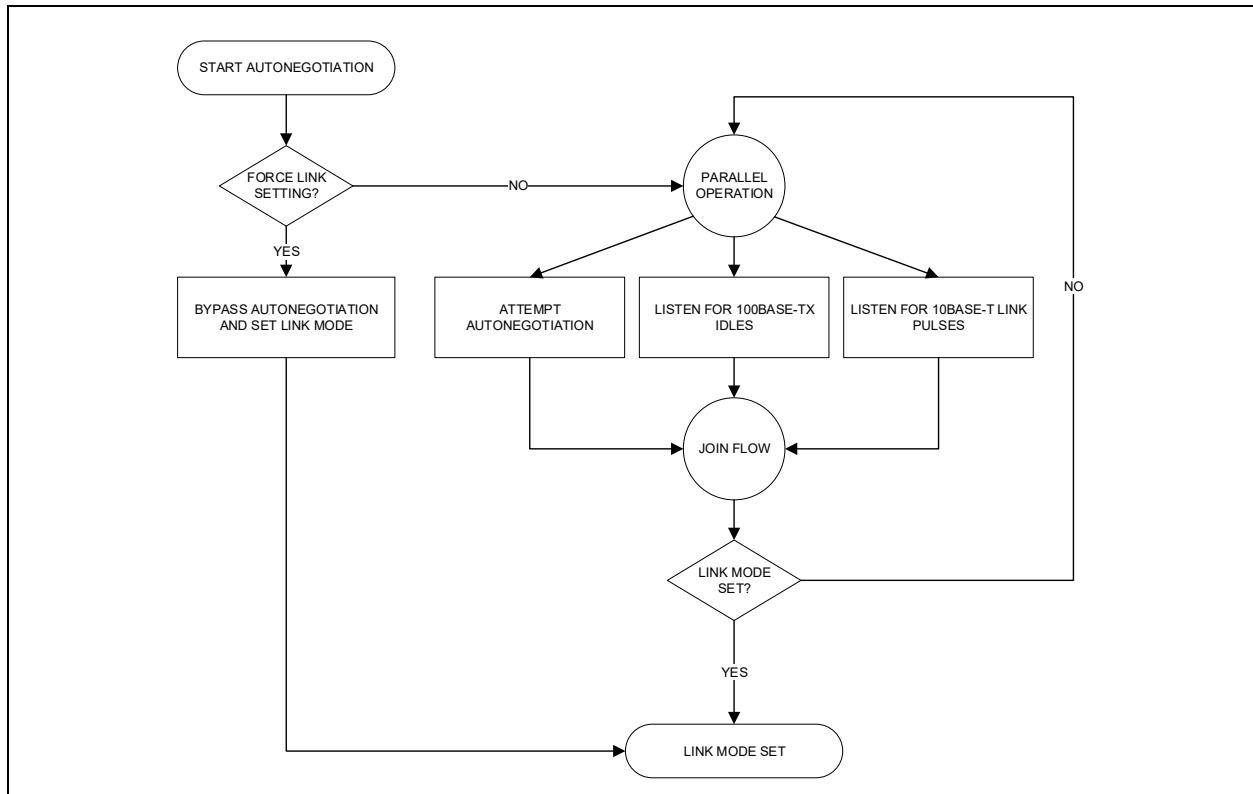

### 3.2 Quiet-Wire® Filtering

Quiet-Wire is a feature to enhance 100BASE-TX EMC performance by reducing both conducted and radiated emissions from the TXP/M signal pair. It can be used either to reduce absolute emissions or to enable replacement of shielded cable with unshielded cable, all while maintaining interoperability with standard 100BASE-TX devices.

Quiet-Wire filtering is implemented internally, with no additional external components required. It is enabled or disabled at power-up and reset by a strapping option on the RXER pin. Once the KSZ8061 is powered up, Quiet-Wire filtering can be disabled by writing to register 16h, bit [12]. Note that Quiet-Wire cannot be enabled via this register bit.

The default setting for Quiet-Wire reduces emissions primarily above 60 MHz, with less reduction at lower frequencies. Several dB of reduction is possible. Signal attenuation is approximately equivalent to increasing the cable length by 10 to 20 meters, thus reducing cable reach by that amount. For applications needing more modest improvement in emissions, the level of filtering can be reduced by writing a series of registers.

### 3.3 Fast Link-Up

Link-up time is normally determined by the time it takes to complete auto-negotiation. Additional time may be added by the auto MDI/MDI-X feature. The total link-up time from power-up or cable connect is typically a second or more.

Fast Link-up mode significantly reduces 100BASE-TX link-up time by disabling both auto-negotiation and auto MDI/MDI-X, and fixing the TX and RX channels. This is done via the CONFIG[2:0] and AUTONEG strapping options. Because these are strapping options, fast link-up is available immediately upon power-up. Fast Link-up is available only for 100BASE-TX link speed. To force the link speed to 10BASE-TX requires a register write.

Fast Link-up mode is intended for specialized applications where both link partners are known in advance. The link must also be known so that the fixed transmit channel of one device connects to the fixed receive channel of the other device, and vice versa.

If a device in Fast Link-up mode is connected to a normal device (auto-negotiate and auto-MDI/MDI-X), there are no problems linking, but the speed advantage of Fast Link-up is realized only on one end.

# KSZ8061RNB/RND

## 3.4 Internal and External RX Termination

By default, the RX differential pair is internally terminated. This minimizes the board component count by eliminating all components between the KSZ8061RNB/RND and the magnetics (transformer and common mode choke). The KSZ8061RNB/RND has the option to turn off the internal termination, to allow the use of external termination. External termination does increase the external component count, but these external components can be of tighter tolerance than the internal termination resistors. Enabling or disabling of the internal RX termination is controlled by register 14h, bit [2].

If external termination is used in place of the internal termination, it should consist of two 50Ω resistors in series between RXP and RXM, with a 0.1 μF to 1 μF capacitor from the midpoint of the two resistors to ground.

## 3.5 RMII Interface

The Reduced Media Independent Interface (RMII) specifies a low pin count Media Independent Interface. It provides a common interface between RMII PHYs and MACs and has the following key characteristics:

- Pin count is 8 pins (3 pins for data transmission, 4 pins for data reception, and 1 pin for the 50-MHz reference clock).
- 10-Mbps and 100-Mbps data rates are supported at both half- and full-duplex.
- Data transmission and reception are independent and belong to separate signal groups.
- Transmit data and receive data are each 2-bit wide, a di-bit.

## 3.6 RMII Signal Definition

Table 3-1 describes the RMII signals. Refer to RMII Specification v1.2 for detailed information.

TABLE 3-1: RMII SIGNAL DEFINITION

RMII Signal Name	KSZ8061RNB/RND Signal and Direction	Direction (with respect to MAC device)	Description
REF_CLK	KSZ8061RNB REF_CLK, Output	Input	Synchronous 50-MHz reference clock for receive, transmit, and control interface
	KSZ8061RND XI, Input	Input or Output	
TX_EN	TXEN, Input	Output	Transmit Enable
TXD[1:0]	TXD[1:0], Input	Output	Transmit Enable
CRS_DV	CRS_DV, Output	Input	Carrier Sense/Receive Data Valid
RXD[1:0]	RXD[1:0], Output	Input	Receive Data [1:0]
RX_ER	RXER, Output	Input	Receive Error

### 3.6.1 REFERENCE CLOCK (REF\_CLK)

REF\_CLK is a continuous 50-MHz clock that provides the timing reference for TXEN, TXD[1:0], CRS\_DV, RXD[1:0], and RXER. The KSZ8061RNB generates and outputs the 50-MHz RMII REF\_CLK to the MAC device at REF\_CLK (pin 19). The KSZ8061RND receives the 50-MHz RMII REF\_CLK from the MAC or system board at XI (pin 1), and leaves the REF\_CLK (pin 19) as no connect.

### 3.6.2 TRANSMIT ENABLE (TXEN)

TXEN indicates the MAC is presenting di-bits on TXD[1:0] for transmission. It is asserted synchronously with the first di-bit of the preamble and remains asserted while all di-bits to be transmitted are presented on the RMII. It is negated prior to the first REF\_CLK following the final di-bit of a frame.

TXEN transitions synchronously with respect to REF\_CLK.

### 3.6.3 TRANSMIT DATA [1:0] (TXD[1:0])

When TXEN is asserted, the PHY accepts TXD[1:0] for transmission. When TXEN is deasserted, the MAC drives TXD[1:0] to 00 for the idle state.

TXD[1:0] transitions synchronously with respect to REF\_CLK.

## 3.6.4 CARRIER SENSE/RECEIVE DATA VALID (CRS\_DV)

The PHY asserts CRS\_DV when the receive medium is non-idle. It is asserted asynchronously when a carrier is detected. This happens when squelch is passed in 10 Mbps mode and when two non-contiguous 0s in 10 bits are detected in 100 Mbps mode. Loss of carrier results in the deassertion of CRS\_DV.

While carrier detection criteria are met, CRS\_DV remains asserted continuously from the first recovered di-bit of the frame through the final recovered di-bit. It is negated before the first REF\_CLK that follows the final di-bit. The data on RXD[1:0] is considered valid after CRS\_DV is asserted. However, because the assertion of CRS\_DV is asynchronous relative to REF\_CLK, the data on RXD[1:0] is 00 until receive signals are properly decoded.

## 3.6.5 RECEIVE DATA[1:0] (RXD[1:0])

For each clock period in which CRS\_DV is asserted, RXD[1:0] transfers a di-bit of recovered data from the PHY. When CRS\_DV is deasserted, the PHY drives RXD[1:0] to 00 for the idle state.

RXD[1:0] transitions synchronously with respect to REF\_CLK.

## 3.6.6 RECEIVE ERROR (RXER)

When CRS\_DV is asserted, RXER is asserted for one or more REF\_CLK periods to indicate that a symbol error (for example, a coding error that a PHY can detect that may otherwise be undetectable by the MAC sub-layer) is detected somewhere in the frame that is being transferred from the PHY to the MAC.

RXER transitions synchronously with respect to REF\_CLK.

## 3.6.7 RMII SIGNAL DIAGRAMS

The KSZ8061RNB RMII pin connections to the MAC are shown in [Figure 3-2](#). The connections for the KSZ8061RND are shown in [Figure 3-3](#).

**FIGURE 3-2: KSZ8061RNB RMII INTERFACE**

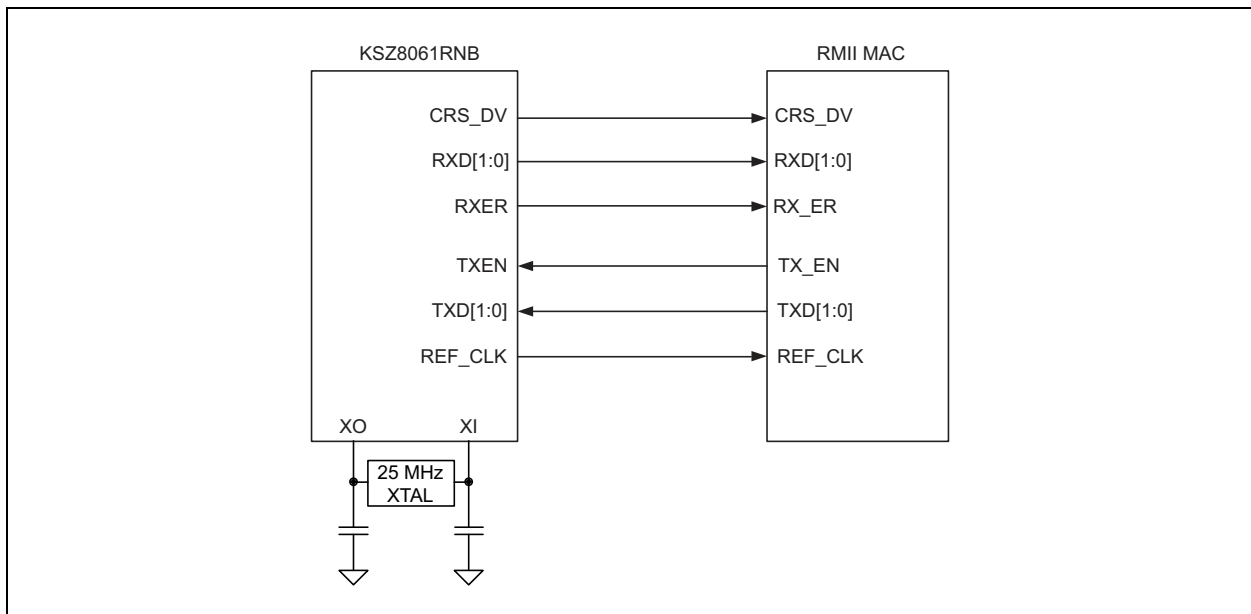

# KSZ8061RNB/RND

**FIGURE 3-3: KSZ8061RND RMII INTERFACE**

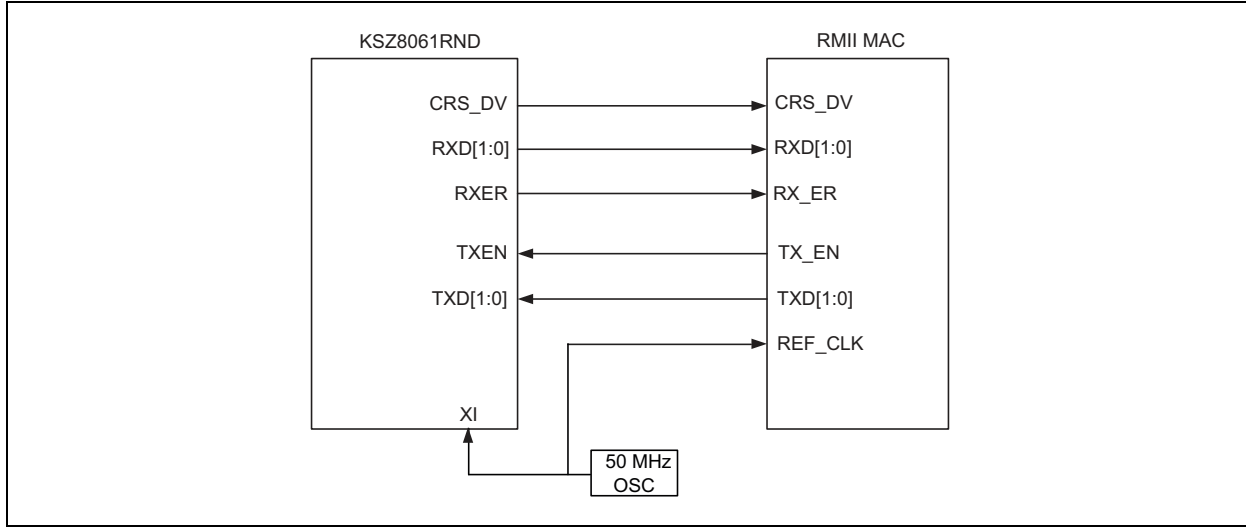

## 3.7 RMII Back-to-Back Mode

Two KSZ8061RND devices can be connected back-to-back to form a 100BASE-TX to 100BASE-TX repeater. For testing purposes, it can also be used to loopback data on the RMII bus by physically connecting the RMII receive bus to the RMII transmit bus.

**FIGURE 3-4: KSZ8061RND TO KSZ8061RND BACK-TO-BACK REPEATER**

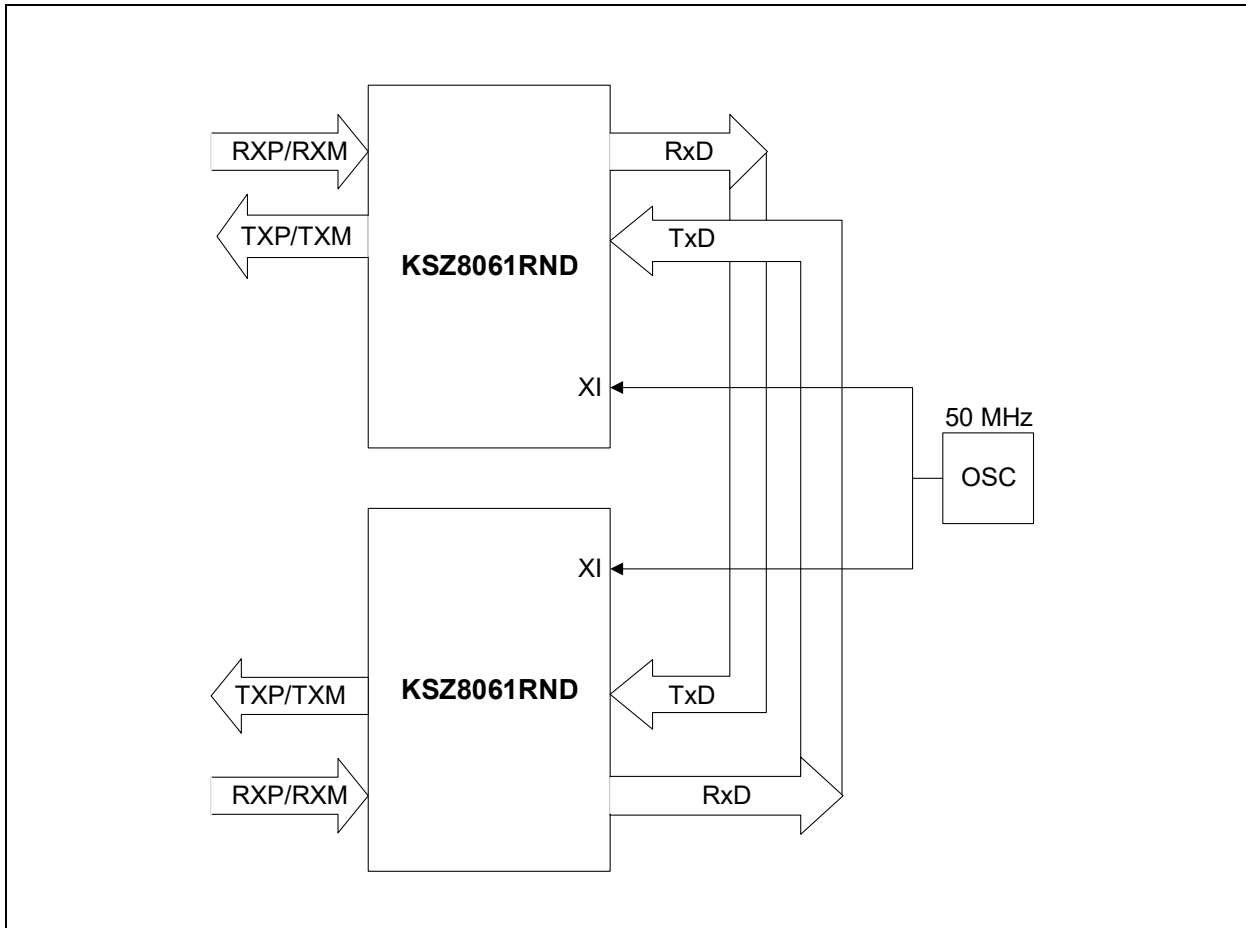

**FIGURE 3-5: KSZ8061RND BACK-TO-BACK FOR RMII BUS LOOPBACK**

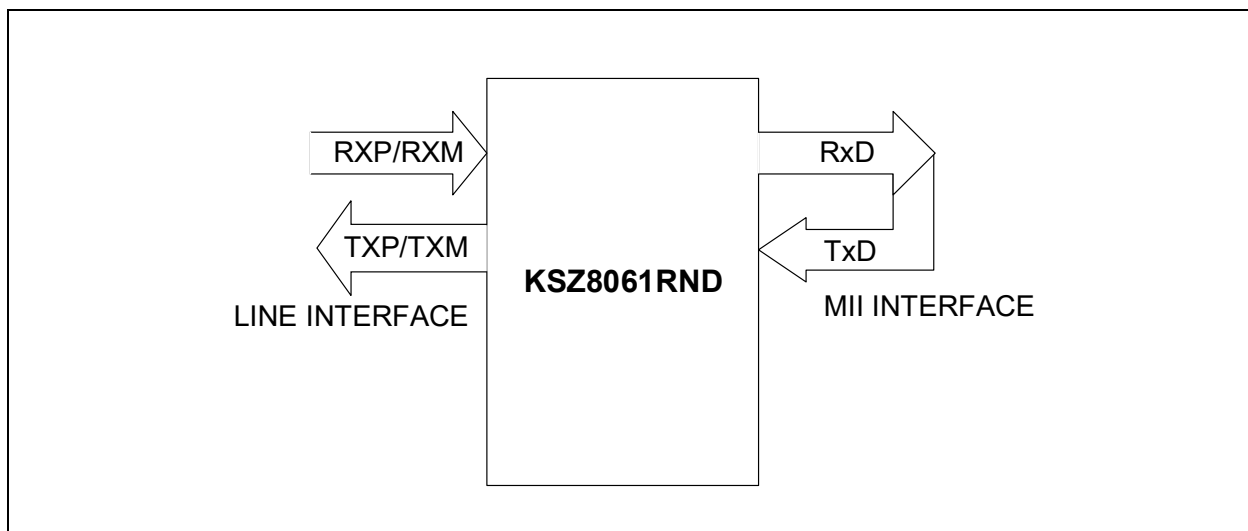

In RMII back-to-back mode, a KSZ8061RND interfaces with another KSZ8061RND to provide a complete 100-Mbps repeater solution.

The KSZ8061RND devices are configured to RMII Back-to-Back mode after power-up or reset with the following:

- Strapping pin CONFIG[2:0] set to '101'
- A common 50-MHz reference clock connected to XI of both KSZ8061RND devices
- RMII signals connected as shown in [Table 3-2](#)

**TABLE 3-2: RMII SIGNAL CONNECTION FOR RMII BACK-TO-BACK MODE**

KSZ8061RND (100BASE-TX) [Device 1]		KSZ8061RND (100BASE-TX) [Device 1 or 2]	
Pin Name	Pin Type	Pin Name	Pin Type
CRS_DV	OUTPUT	TXEN	INPUT
RXD1	OUTPUT	TXD1	INPUT
RXD0	OUTPUT	TXD0	INPUT
TXEN	INPUT	CRS_DV	OUTPUT
TXD1	INPUT	RXD1	OUTPUT
TXD0	INPUT	RXD0	OUTPUT

### 3.8 MII Management (MIIM) Interface

The KSZ8061RNB/RND supports the IEEE 802.3 MII Management Interface, also known as the Management Data Input/Output (MDIO) Interface. This interface enables an upper-layer device, like a MAC processor, to monitor and control the state of the KSZ8061RNB/RND. An external device with MIIM capability is used to read the PHY status, or to configure the PHY settings, or both. Further details on the MIIM interface can be found in Clause 22.2.4 of the IEEE 802.3 Specification.

The MIIM interface consists of the following:

- A physical connection that incorporates the clock line (MDC) and the data line (MDIO).
- A specific protocol that operates across the aforementioned physical connection that allows the external controller to communicate with one or more PHY devices.
- A set of 16-bit MDIO registers. Supported registers [0:8] are standard registers, and their functions are defined per the IEEE 802.3 Specification. The additional registers are provided for expanded functionality. See [Section 4.0, "Register Map"](#) for details.

# KSZ8061RNB/RND

The KSZ8061RNB/RND supports unique PHY addresses 1 to 7, and broadcast PHY address 0. The broadcast address is defined per the IEEE 802.3 Specification, and can be used to write to multiple KSZ8061RNB/RND devices simultaneously.

The PHYAD[2:0] strapping pins are used to assign a unique PHY address between 1 and 7 to each KSZ8061RNB/RND device.

Table 3-3 shows the MII Management frame format.

**TABLE 3-3: MII MANAGEMENT FRAME FORMAT**

	Preamble	Start of Frame	Read/Write OP Code	PHY Address Bits [4:0]	REG Address Bits [4:0]	TA	Data Bits [15:0]	Idle
<b>Read</b>	32 1's	01	10	00AAA	RRRRR	Z0	DDDDDDDD_DDDDDDDD	Z
<b>Write</b>	32 1's	01	01	00AAA	RRRRR	10	DDDDDDDD_DDDDDDDD	Z

## 3.9 LED Output Pins

The LED0 and LED1 pins indicate link status and is intended for driving LEDs. They are active low and can sink current directly from the LEDs. By default, LED0 indicates Link/Activity, and LED1 indicates Link Speed. Bits [5:4] in register 1Fh allow the definition of these pins to be changed to Link Status and Activity, respectively.

- Link Status: The LED indicates that the serial link is up.
- Link/Activity: When the link is up, but there is no traffic, the LED is on. When packets are being received or transmitted, the LED blinks.
- Activity: The LED blinks when packets are received or transmitted. It is off when there is no activity.
- Speed: When the link is up, the LED is on to indicate a 100BASE-TX link and is off to indicate a 10BASE-T link.

## 3.10 Interrupt (INTRP)

INTRP is an interrupt output signal that may be used to inform the external controller that there has been a status update to the KSZ8061RNB/RND PHY register. This eliminates the need for the processor to poll the PHY for status changes such as link up or down.

Register 1Bh, bits [15:8] are the interrupt control bits to enable and disable the conditions for asserting the INTRP signal. Register 1Bh, bits [7:0] are the interrupt status bits to indicate which interrupt conditions have occurred. The interrupt status bits are cleared after reading register 1Bh.

Register 1Fh, bit [9] sets the interrupt level to active-high or active-low. The default is active-low.

## 3.11 HP Auto MDI/MDI-X

HP Auto MDI/MDI-X configuration eliminates the confusion of whether to use a straight cable or a crossover cable between the KSZ8061RNB/RND and its link partner. This feature allows the KSZ8061RNB/RND to use either type of cable to connect with a link partner that is in either MDI or MDI-X mode. The auto-sense function detects transmit and receive pairs from the link partner and then assigns transmit and receive pairs of the KSZ8061RNB/RND accordingly.

Auto MDI/MDI-X is initially enabled or disabled at hardware reset by hardware pin strapping (CONFIG[2:0]). Afterwards, it can be enabled or disabled by register 1Fh, bit [13]. When Auto MDI/MDI-X is disabled, serial data is normally transmitted on the pin pair TXP/TXM, and data is received on RXP/RXM. However, this may be reversed by writing to register 1Fh, bit [14].

An isolation transformer with symmetrical transmit and receive data paths is recommended to support Auto MDI/MDI-X.

Table 3-4 illustrates how the IEEE 802.3 Standard defines MDI and MDI-X.



**TABLE 3-4: MDI/MDI-X PIN DEFINITION**

MDI		MDI-X	
RJ-45 Pin	Signal	RJ-45 Pin	Signal
1	TX+	1	RX+
2	TX-	2	RX-
3	RX+	3	TX+
6	RX-	6	TX-

### 3.12 Straight Cable

A straight cable connects an MDI device to an MDI-X device, or an MDI-X device to an MDI device. [Figure 3-6](#) depicts a typical straight cable connection between a NIC card (MDI device) and a switch, or hub (MDI-X device).

**FIGURE 3-6: TYPICAL STRAIGHT CABLE CONNECTION**

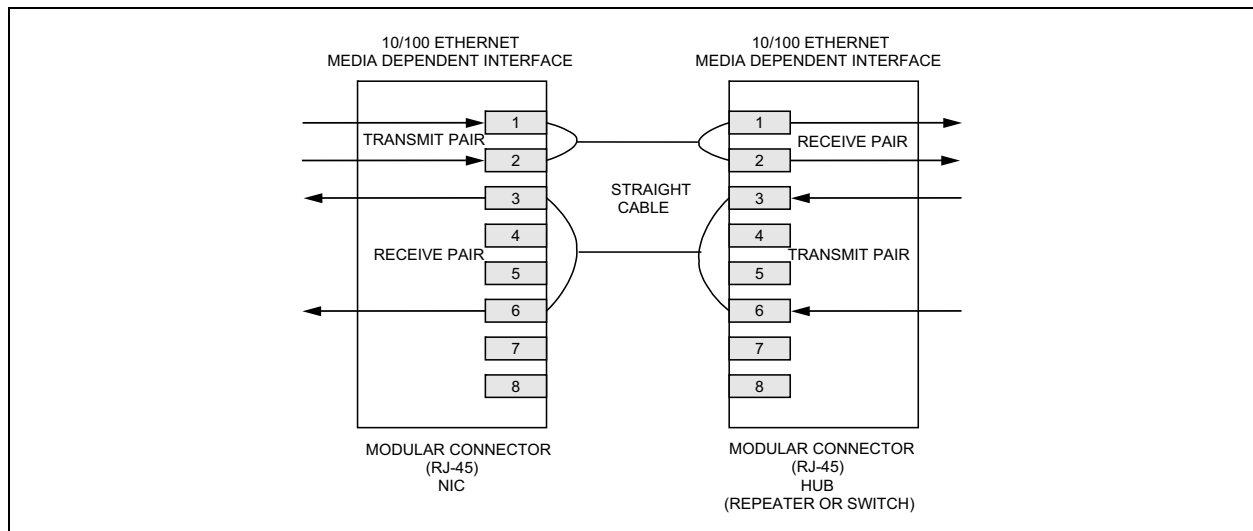

### 3.13 Crossover Cable

A crossover cable connects an MDI device to another MDI device, or an MDI-X device to another MDI-X device. [Figure 3-7](#) depicts a typical crossover cable connection between two switches or hubs (two MDI-X devices).

**FIGURE 3-7: TYPICAL CROSSOVER CABLE CONNECTION**

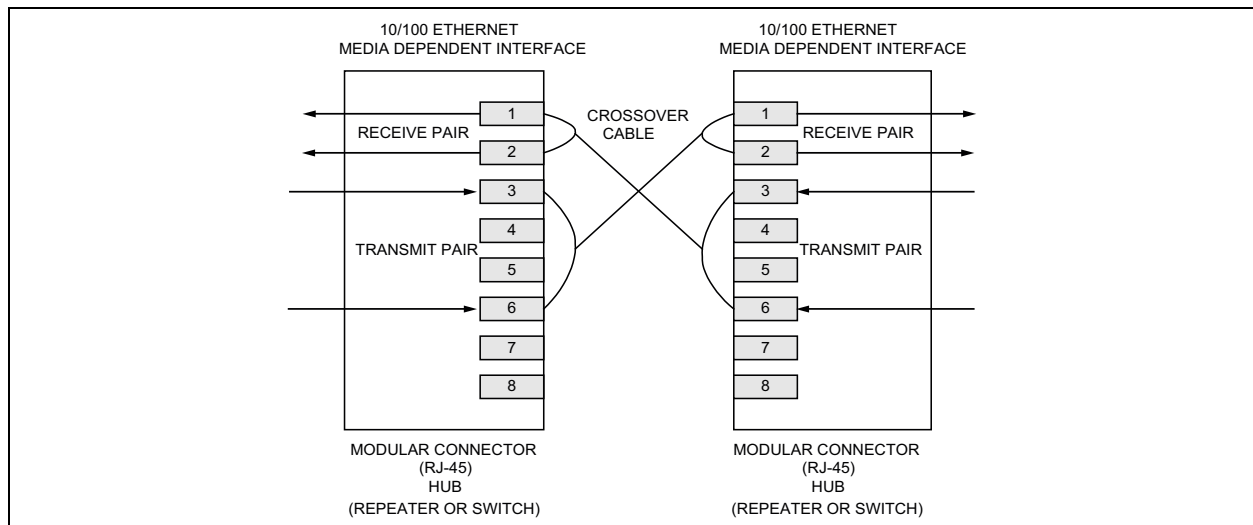

# KSZ8061RNB/RND

## 3.14 Loopback Modes

The KSZ8061RNB/RND supports the following loopback operations to verify analog and/or digital data paths:

- Local (Digital) Loopback
- Remote (Analog) Loopback

### 3.14.1 LOCAL (DIGITAL) LOOPBACK MODE

This loopback mode is a diagnostic mode for checking the RMIIT transmit and receive data paths between KSZ8061RNB/RND and an external MAC, and is supported for both speeds (10/100 Mbps) at full-duplex.

The loopback data path is shown in [Figure 3-8](#).

1. RMIIT MAC transmits frames to KSZ8061RNB/RND.
2. Frames are wrapped around inside KSZ8061RNB/RND.
3. KSZ8061RNB/RND transmits frames back to RMIIT MAC.

**FIGURE 3-8: LOCAL (DIGITAL) LOOPBACK**

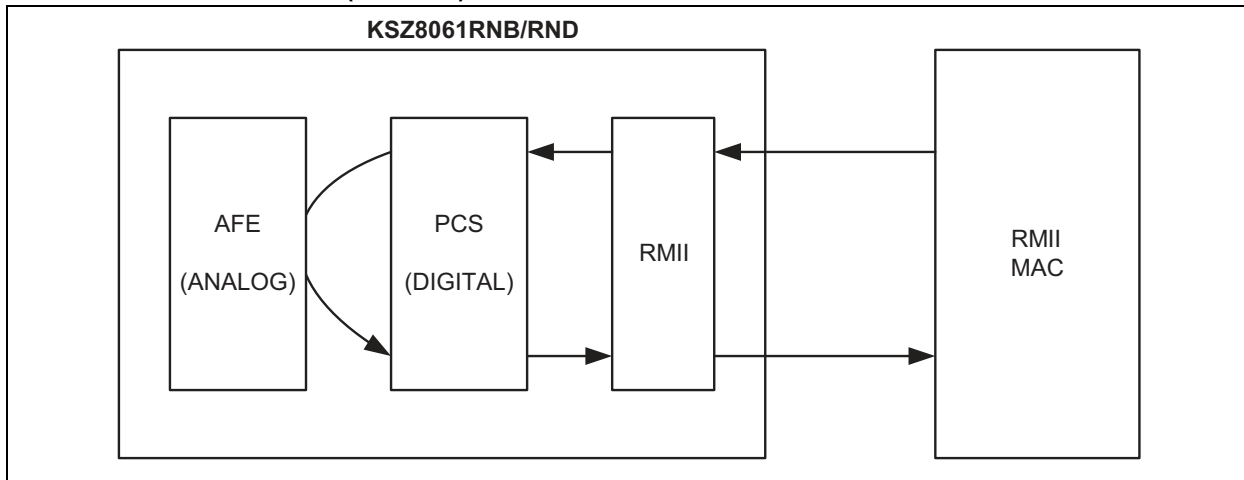

The following programming steps and register settings are used for Local Loopback mode.

For 10/100 Mbps loopback:

Set Register 0h,

- Bit [14] = 1 // Enable Local Loopback mode
- Bit [13] = 0 / 1 // Select 10 Mbps / 100 Mbps speed
- Bit [12] = 0 // Disable Auto-Negotiation
- Bit [8] = 1 // Select full-duplex mode

Set Register 1Ch,

- Bit [5] = 1

### 3.14.2 REMOTE (ANALOG) LOOPBACK

This loopback mode checks the line (differential pairs, transformer, RJ-45 connector, and Ethernet cable) transmit and receive data paths between KSZ8061RNB/RND and its link partner, and is supported for 100BASE-TX full-duplex mode only.

The loopback data path is shown in [Figure 3-9](#).

- Fast Ethernet (100BASE-TX) PHY link partner transmits frames to KSZ8061RNB/RND.
- Frames are wrapped around inside KSZ8061RNB/RND.
- KSZ8061RNB/RND transmits frames back to fast Ethernet (100BASE-TX) PHY link partner.

**FIGURE 3-9: REMOTE (ANALOG) LOOPBACK**

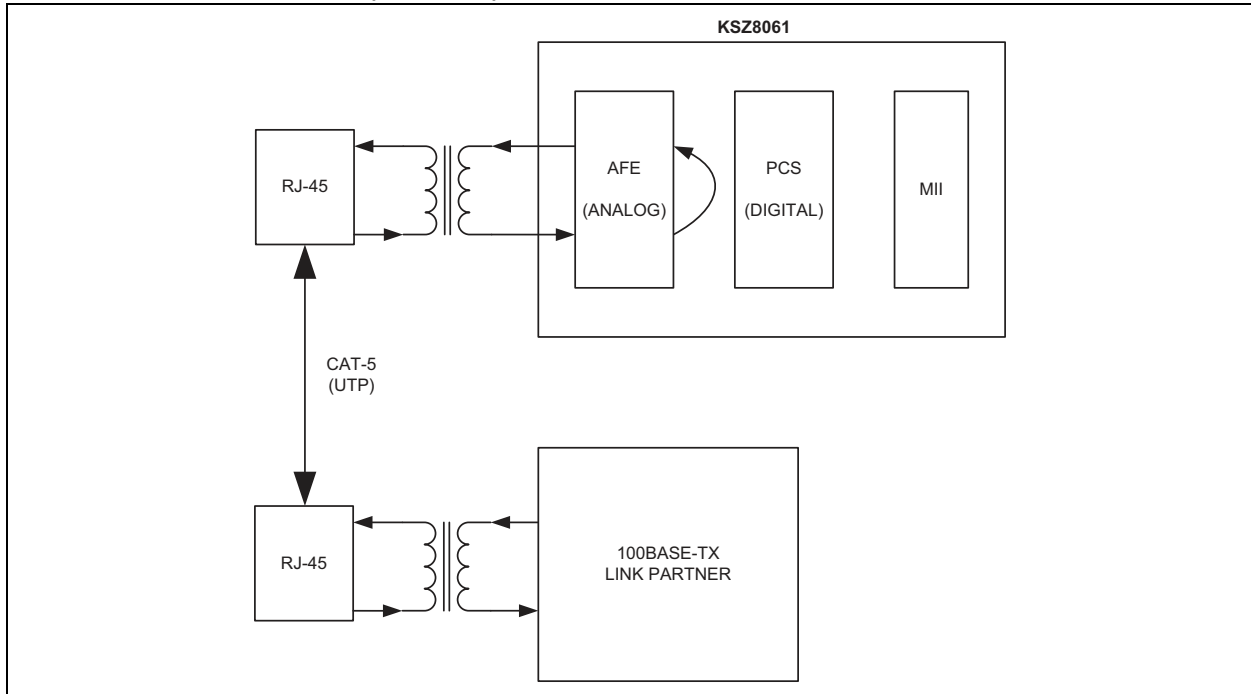

The following programming steps and register settings are used for Remote Loopback mode.

Set Register 0h,

- Bit [13] = 1 // Select 100 Mbps speed
- Bit [12] = 0 // Disable Auto-Negotiation
- Bit [8] = 1 // Select full-duplex mode

Or simply auto-negotiate and link up at 100BASE-TX full-duplex mode with link partner.

Set Register 1Fh,

- Bit [2] = 1 // Enable Remote Loopback mode

### 3.15 LinkMD<sup>®</sup> Cable Diagnostics

The LinkMD<sup>®</sup> function utilizes time domain reflectometry (TDR) to analyze the cabling plant for common cabling problems, such as open circuits, short circuits, and impedance mismatches.

LinkMD works by sending a pulse of known amplitude and duration down the MDI or MDI-X pair, and then analyzing the shape of the reflected signal to determine the type of fault. The time duration for the reflected signal to return provides the approximate distance to the cabling fault. The LinkMD function processes this TDR information and presents it as a numerical value that can be translated to a cable distance.

LinkMD is initiated by accessing the LinkMD Control/Status Register (register 1Dh) and the PHY Control 2 Register (register 1Fh). The latter register is used to disable auto MDI/MDIX and to select either MDI or MDI-X as the cable differential pair for testing.

A two-step process is used to analyze the cable. The first step uses a small pulse (for short cables), while the second step uses a larger pulse (for long cables). The steps are as follows:

Step 1:

1. Write MMD address 1Bh, register 0, bits [7:4] = 0x2. Note that this is the power-up default value.
2. Write register 13h, bit [15] = 0. Note that this is the power-up default value.
3. Write register 1Fh. Disable auto MDI/MDI-X in bit [13], and select either MDI or MDI-X in bit [14] to specify the twisted pair to test.
4. Write register 1Dh bit [15] = 1 to initiate the LinkMD test.
5. Read register 1Dh to determine the result of the first step. Bit [15] = 0 indicates that the test is complete. After that, the result is read in bits [14:12]. Remember the result.

# KSZ8061RNB/RND

Step 2:

1. Write MMD address 1Bh, register 0, bits [7:4] = 0x7.
2. Write register 13h, bit [15] = 1.
3. Write register 1Dh bit [15] = 1 to initiate the LinkMD test.
4. Read register 1Dh to determine the result of the first step. Bit [15] = 0 indicates that the test is complete. After that, the result is read in bits [14:12].

Register 1Dh bits [14:13] indicate the basic result of the test. When an Open or Short condition is reported, the distance to the open or short is determined from the distance value read from register bits [8:0].

$$\text{Distance (m)} = (\text{count value} * 4(\text{ns})/4.8(\text{ns/m})) / 2$$

When Normal condition is reported, the distance value is not relevant.

If either step reveals a short, then there is a short. If either step reveals an open, then there is an open. If both tests indicate normal, then the cable is normal.

## 3.16 LinkMD<sup>®</sup>+ Enhanced Diagnostics: Receive Signal Quality Indicator

The KSZ8061RN provides a receive Signal Quality Indicator (SQI) feature, which indicates the relative quality of the 100BASE-TX receive signal. It approximates a signal-to-noise ratio, and is affected by cable length, cable quality, and environmental EM noise.

The raw SQI value is available for reading at any time from indirect register: MMD 1Ch, register ACh, bits [14:8]. A lower value indicates better signal quality, while a higher value indicates worse signal quality. Even in a stable configuration in a low-noise environment, the value read from this register may vary. The value should therefore be averaged by taking multiple readings. The update interval of the SQI register is 2  $\mu$ s, so measurements taken more frequently than 2  $\mu$ s are redundant. In a quiet environment, 6 to 10 readings are suggested for averaging. In a noisy environment, individual readings are unreliable, so a minimum of 30 readings are suggested for averaging. The SQI circuit does not include any hysteresis.

Table 3-5 lists typical SQI values for various CAT5 cable lengths when linked to a typical 100BASE-TX device in a quiet environment. In a noisy environment or during immunity testing, the SQI value increases.

**TABLE 3-5: TYPICAL SQI VALUES**

CAT5 Cable Length	Typical SQI Value (MMD 1Ch, register ACh, bits [14:8])
10m	2
30m	2
50m	3
80m	3
100m	4
130m	5

## 3.17 NAND Tree Support

The KSZ8061RNB/RND provides parametric NAND tree support for fault detection between chip I/Os and board. The NAND tree is a chain of nested NAND gates in which each KSZ8061RNB/RND digital I/O (NAND tree input) pin is an input to one NAND gate along the chain. At the end of the chain, the CONFIG1 pin provides the output for the next NAND gates.

The NAND tree test process includes:

- Enabling NAND tree mode
- Pulling all NAND tree input pins high
- Driving low each NAND tree input pin sequentially per the NAND tree pin order
- Checking the NAND tree output to ensure there is a toggle high-to-low or low-to-high for each NAND tree input driven low

Table 3-6 lists the NAND tree pin order.

**TABLE 3-6: KSZ8061RNB/RND NAND TREE TEST PIN ORDER**

Pin Number	Pin Name	NAND Tree Description
10	MDIO	INPUT
11	MDC	INPUT
12	RXER	INPUT
13	CRS_DV	INPUT
14	PHYAD0	INPUT
16	PHYAD1	INPUT
17	RXD1	INPUT
18	RXD0	INPUT
19	REF_CLK	INPUT
20	DNU	INPUT
21	TXEN	INPUT
22	TXD0	INPUT
23	TXD1	INPUT
24	LED0	INPUT
25	DNU	INPUT
26	DNU	INPUT
29	INTRP	INPUT
27	CONFIG	OUTPUT

### 3.18 NAND Tree I/O Testing

The following procedure can be used to check for faults on the KSZ8061RNB/RND digital I/O pin connections to the board:

1. Enable NAND tree mode by INTRP pin strapping option.
2. Use board logic to drive all KSZ8061RNB/RND NAND tree input pins high.
3. Use board logic to drive each NAND tree input pin, per KSZ8061RNB/RND NAND Tree pin order, as follows:
  - a) Toggle the first pin (MDIO) from high to low, and verify the CONFIG1 pin switch from high to low to indicate that the first pin is connected properly.
  - b) Leave the first pin (MDIO) low.
  - c) Toggle the second pin (MDC) from high to low, and verify the CONFIG1 pin switch from low to high to indicate that the second pin is connected properly.
  - d) Leave the first pin (MDIO) and the second pin (MDC) low.
  - e) Toggle the third pin (RXER) from high to low, and verify the CONFIG1 pin switch from high to low to indicate that the third pin is connected properly.
  - f) Continue with this sequence until all KSZ8061RNB/RND NAND tree input pins have been toggled.

Each KSZ8061RNB/RND NAND tree input pin must cause the CONFIG1 output pin to toggle high-to-low or low-to-high to indicate a good connection. If the CONFIG1 pin fails to toggle when the KSZ8061RNB/RND input pin toggles from high to low, the input pin has a fault.

# KSZ8061RNB/RND

---

## 3.19 Power Management

The KSZ8061RNB/RND offers the following power management modes which are enabled and disabled by register control.

### 3.19.1 POWER SAVING MODE

Power Saving mode is used to reduce the transceiver power consumption when the cable is unplugged. This mode does not interfere with normal device operation. It is enabled by writing a one to register 1Fh, bit [10], and is in effect when auto-negotiation mode is enabled and the cable is disconnected (no link). In this mode, the KSZ8061RNB/RND shuts down all transceiver blocks except for the transmitter, energy detect, and PLL circuits. By default, Power Saving mode is disabled after power-up.

### 3.19.2 ENERGY-DETECT POWER-DOWN MODE

Energy-Detect Power-Down (EDPD) mode is used to further reduce the transceiver power consumption when the cable is unplugged, relative to Power Saving mode. This mode does not interfere with normal device operation. It is enabled by writing a zero to register 18h, bit [11], and is in effect when auto-negotiation mode is enabled and cable is disconnected (no link).

EDPD mode can be optionally enhanced with a PLL Off feature, which turns off all KSZ8061RNB/RND transceiver blocks, except for transmitter and energy detect circuits. PLL Off is set by writing a one to register 10h, bit [4].

Further power reduction is achieved by extending the time interval in between transmissions of link pulses while in this mode. The periodic transmission of link pulses is needed to ensure two link partners in the same low powered state with auto MDI/MDI-X disabled can wake up when the cable is connected between them.

By default, EDPD mode is disabled after power-up.

### 3.19.3 POWER-DOWN MODE

Power-Down mode is used to power down the KSZ8061RNB/RND when it is not in use after power-up. It is enabled by writing a one to register 0h, bit [11].

In this mode, the KSZ8061RNB/RND disables all internal functions except the MII management interface. The KSZ8061RNB/RND exits (disables) the Power-Down mode after register 0h, bit [11] is set back to zero.

### 3.19.4 SLOW OSCILLATOR MODE

Slow Oscillator mode is used to disconnect the input reference crystal/clock on XI (pin 1) and select the on-chip slow oscillator when the KSZ8061RNB/RND is not in use after power-up. It is enabled by writing a one to register 11h, bit [6].

Slow Oscillator mode works in conjunction with Power-Down mode to put the KSZ8061RNB/RND into a lower power state with all internal functions disabled, except for the MII management interface. To properly exit this mode and return to normal PHY operation, use the following programming sequence:

1. Disable Slow Oscillator mode by writing a zero to register 11h, bit [6].
2. Disable Power-Down mode by writing a zero to register 0h, bit [11].
3. Initiate software reset by writing a one to register 0h, bit [15].

### 3.19.5 ULTRA-DEEP SLEEP MODE

Ultra-Deep Sleep mode is used to achieve the lowest possible power consumption while retaining the ability to detect activity on the Tx/Rx cable pairs, and is intended for achieving negligible battery drain during long periods of inactivity. It is controlled by several register bits, and Ultra-Deep Sleep mode may be entered by writing to a register, or it may be initiated automatically when Signal Detect (SIGDET) is deasserted. Details are given in the Signal Detect (SIGDET) and Ultra-Deep Sleep mode section.

In Ultra-Deep Sleep mode, the KSZ8061RNB/RND disables all internal functions and I/Os except for the ultra-low power signal detect circuit and the Signal Detect pin (SIGDET), which are powered from VDDIO. For lowest power consumption, the 1.2V supply (VDDL and AVDDL) may be turned off externally. Hardware reset is required to exit Ultra-Deep Sleep mode.

## 3.19.6 NON-VOLATILE REGISTERS

Most of the logic circuitry of the KSZ8061RNB/RND, including the status and control registers, is powered by the 1.2V supply. When the 1.2V supply is turned off in Ultra-Deep Sleep mode, the content of the registers is lost. Because of the importance of register 14h and bit [0] of register 13h, which control the various power modes, these bits are duplicated in a logic block powered by the 3.3V supply. These register bits are therefore “non-volatile” while in Ultra-Deep Sleep mode.

To access the non-volatile (3.3V) registers, bit [4] of register 14h must first be set. Otherwise, writes to these registers modify only the volatile versions of these registers, and not the non-volatile versions.

## 3.20 Signal Detect (SIGDET) and Ultra-Deep Sleep Mode

SIGDET is an output signal which may be used for power reduction, either by directly turning off selected power or by signaling to a host controller when no signal is detected on the line interface. It is asserted when sufficient energy is detected on either of the differential pairs, and is deasserted when cable energy is not detected. The signal detection circuit consumes almost no power from the VDDIO supply, and does not use the 1.2V supply at all.

Ultra-Deep Sleep mode may be entered either automatically in unison with the Signal Detect signal (Automatic method), or manually by setting a register bit (CPU Control method).

The signal detect feature and Ultra-Deep Sleep mode are controlled via multiple bits in register 14h:

- Register 14h, bit [6] Ultra-Deep Sleep method: either Automatic or CPU Control
- Register 14h, bit [5] Manually enter Ultra Deep Sleep mode when CPU Control method is selected
- Register 14h, bit [4] Enable R/W access to non-volatile versions of register 14h and bits [9:8] and [1:0] of register 13h. Set this bit when bit [3] is set.
- Register 14h, bit [3] Enable Ultra Deep Sleep mode and SIGDET
- Register 14h, bit [1] Extend timing for SIGDET deassertion and entry into Ultra-Deep Sleep mode
- Register 14h, bit [0] SIGDET output polarity

### 3.20.1 CPU CONTROL METHOD (MIIM INTERFACE)

- KSZ8061RNB/RND drives SIGDET signal to the CPU.
- SIGDET defaults to force high, to not interfere with PHY initialization by the CPU. At power-on, the KSZ8061RNB/RND drives SIGDET high, without consideration of cable energy level.
- During initialization, the CPU writes data 0x0058 to register 14h.
  - Bit [4] enables access to the non-volatile copy of register 14h.
  - Enable Ultra-Deep Sleep mode and SIGDET by setting register 14h, bit [3].
  - Automatic Ultra-Deep Sleep functionality is disabled by setting register 14h, bit [6].
- SIGDET is now enabled and changes state as cable energy changes.
- In response to the deassertion of SIGDET, the CPU puts KSZ8061RNB/RND into Ultra-Deep Sleep mode by setting register 14h, bit [5]. To further reduce power, the CPU may disable the 1.2V supply to the KSZ8061RNB/RND.
- The KSZ8061RNB/RND asserts SIGDET when energy is detected on the cable.
- To activate the KSZ8061RNB/RND, the CPU enables the 1.2V supply and asserts hardware reset (RESET#) to the KSZ8061RNB/RND. Because the KSZ8061RNB/RND is completely reset, the registers must be re-initialized.
- Alternately, it is possible to maintain register access during Ultra-Deep Sleep mode by preserving the 1.2V power supply and setting register 13h, bit [0] to enable slow oscillator mode. Ultra-Deep Sleep mode can then be exited by writing to register 14h. The 1.2V supply results in increased power consumption.

### 3.20.2 AUTOMATIC STANDBY METHOD

- The board may be designed such that the KSZ8061RNB/RND SIGDET signal enables the 1.2V power supply to KSZ8061RNB/RND.
- At power-on, the KSZ8061RNB/RND drives SIGDET high, without consideration of cable energy level.
- During initialization, CPU writes data 0x001A or 0x0018 to register 14h.
  - Bit [4] enables access to the non-volatile copy of register 14h.
  - Enable Ultra-Deep Sleep mode and SIGDET by setting register 14h, bit [3].
  - Automatic Ultra-Deep Sleep functionality is enabled by clearing register 14h, bit [6].
  - SIGDET timing bit [1] must be set unless the link partner is not using auto-negotiation, auto-MDI/MDI-X is dis-

# KSZ8061RNB/RND

---

abled, and link is at 100 Mbps.

- When the KSZ8061RNB/RND detects signal loss, it automatically enters Ultra-Deep Sleep mode and deasserts SIGDET. SIGDET may be used to disable the 1.2V supply.
- When the KSZ8061RNB/RND detects a signal, it asserts SIGDET (which enables the 1.2V supply) and automatically wakes up. SIGDET may be used to wake up the CPU, which then re-initializes the KSZ8061RNB/RND.
- Alternatively, a hardware reset (RESET#) brings the KSZ8061RNB/RND out of Ultra-Deep Sleep mode.
- The contents of register 14h and bits [9:8] and [1:0] of register 13h are preserved during Ultra-Deep Sleep mode, but are lost during hardware reset.



## 4.0 REGISTER MAP

The register space within the KSZ8061RNB/RND consists of two distinct areas:

- Standard registers // Direct register access
- MDIO Manageable device (MMD) registers // Indirect register access

**TABLE 4-1: STANDARD REGISTERS**

Register Number (hex)	Description
<b>IEEE-Defined Registers</b>	
0h	Basic Control
1h	Basic Status
2h	PHY Identifier 1
3h	PHY Identifier 2
4h	Auto-Negotiation Advertisement
5h	Auto-Negotiation Link Partner Ability
6h	Auto-Negotiation Expansion
7h	Auto-Negotiation Next Page
8h	Auto-Negotiation Link Partner Next Page Ability
9h - Ch	Reserved
Dh	MMD Access Control Register
Eh	MMD Access Address Data Register
Fh	Reserved
<b>Vendor-Specific Registers</b>	
10h	Digital Control
11h	AFE Control 0
12h	AFE Control 1
13h	AFE Control 2
14h	AFE Control 3
15h	RXER Counter
16h	Operation Mode
17h	Operation Mode Strap Status
18h	Expanded Control
19h - 1Ah	Reserved
1Bh	Interrupt Control/Status
1Ch	Function Control
1Dh	LinkMD <sup>®</sup> Control/Status
1Eh	PHY Control 1
1Fh	PHY Control 2

**TABLE 4-2: MMD REGISTERS**

Device Address (Hex)	Register Address (Hex)	Description
7h	3Ch	Reserved
	3Dh	Reserved
1Bh	0h	AFED Control
1Ch	ACh	Signal Quality

# KSZ8061RNB/RND

## 4.1 Standard Registers

Standard registers provide direct read/ or write access to a 32-register address space, as defined in Clause 22 of the IEEE 802.3 standard. Within this address space, the first 16 registers (0h to Fh) are defined according to the IEEE Specification, while the remaining 16 registers (10h to 1Fh) are defined specific to the PHY vendor.

**TABLE 4-3: STANDARD REGISTER DESCRIPTION**

Address	Name	Description	Mode (Note 4-1)	Default
<b>Register 0h - Basic Control</b>				
0.15	Reset	1 = Software reset 0 = Normal operation This bit is self-cleared after a '1' is written to it.	RW/SC	0
0.14	Loopback	1 = Loop-back mode (RMII TX to RMII RX. Line side is disconnected.) 0 = Normal operation Loopback must be enabled both here and in register 1Ch.	RW	0
0.13	Speed Select	1 = 100 Mbps 0 = 10 Mbps This bit is ignored if auto-negotiation is enabled (register 0.12 = 1).	RW	1
0.12	Auto-Negotiation Enable	1 = Enable auto-negotiation process 0 = Disable auto-negotiation process If enabled, auto-negotiation result overrides settings in register 0.13 and 0.8.	RW	Set by AUTONEG strapping pin. See <a href="#">Table 2-2</a> for details.
0.11	Power Down	1 = Power down mode 0 = Normal operation If software reset (register 0.15) is used to exit Power Down mode (register 0.11 = 1), two software reset writes (register 0.15 = 1) are required. First write clears Power Down mode; second write resets chip and re-latches the pin strapping pin values.	RW	0
0.10	Isolate	1 = Electrical isolation of PHY from RMII 0 = Normal operation	RW	0
0.9	Restart Auto-Negotiation	1 = Restart auto-negotiation process 0 = Normal operation. This bit is self-cleared after a '1' is written to it.	RW/SC	0
0.8	Duplex Mode	1 = Full-duplex 0 = Half-duplex	RW	1
0.7	Collision Test	1 = Enable COL test 0 = Disable COL test	RW	0
0.6:0	Reserved	—	RO	000_0000
<b>Register 1h - Basic Status</b>				
1.15	100BASE-T4	1 = T4 capable 0 = Not T4 capable	RO	0
1.14	100BASE-TX Full-Duplex	1 = Capable of 10 Mbps half-duplex 0 = Not capable of 10 Mbps half-duplex	RO	1
1.13	100BASE-TX Half-Duplex	1 = Capable of 10 Mbps half-duplex 0 = Not capable of 10 Mbps half-duplex	RO	1
1.12	10BASE-TX Full-Duplex	1 = Capable of 10 Mbps half-duplex 0 = Not capable of 10 Mbps half-duplex	RO	1

**TABLE 4-3: STANDARD REGISTER DESCRIPTION (CONTINUED)**

Address	Name	Description	Mode (Note 4-1)	Default
1.11	10BASE-TX Half-Duplex	1 = Capable of 10 Mbps half-duplex 0 = Not capable of 10 Mbps half-duplex	RO	1
1.10:7	Reserved	—	RO	000_0
1.6	No Preamble	1 = Preamble suppression acceptable 0 = Normal preamble required	RW	1
1.5	Auto-Negotiation Complete	1 = Auto-negotiation process completed 0 = Auto-negotiation process not completed	RO	0
1.4	Remote Fault	1 = Remote fault 0 = No remote fault	RO/LH	0
1.3	Auto-Negotiation Ability	1 = Capable to perform auto-negotiation 0 = Not capable to perform auto-negotiation	RO	1
1.2	Link Status	1 = Link is up 0 = Link is down	RO/LL	0
1.1	Jabber Detect	1 = Jabber detected 0 = Jabber not detected (default is low)	RO/LH	0
1.0	Extended Capability	1 = Supports extended capabilities registers	RO	1
<b>Register 2h - PHY Identifier 1</b>				
2.15.0	PHY ID Number	Assigned to the 3rd through 18th bits of the Organizationally Unique Identifier (OUI). Kendin Communication's OUI is 0010A1 (hex)	RO	0022h
<b>Register 3h - PHY Identifier 2</b>				
3.15:10	PHY ID Number	Assigned to the 19th through 24th bits of the Organizationally Unique Identifier (OUI). Kendin Communication's OUI is 0010A1 (hex)	RO	0001_01
3.0:4	Model Number	Six bit manufacturer's model number	RO	01_0111
3.3:0	Revision Number	Four bit manufacturer's revision number	RO	Indicates silicon revision
<b>Register 4h - Auto-Negotiation Advertisement</b>				
4.15	NextPage	1 = Next page capable 0 = No next page capability	RW	1
4.14	Reserved	—	RO	0
4.13	Remote Fault	1 = Remote fault supported 0 = No remote fault	RW	0
4.12	Reserved	—	RO	0
4.11:10	Pause	[00] = No PAUSE [10] = Asymmetric PAUSE [01] = Symmetric PAUSE [11] = Asymmetric & Symmetric PAUSE	RW	00
4.9	100BASE-T4	1 = T4 capable 0 = No T4 capability	RO	0
4.8	100BASE-TX Full-Duplex	1 = 100 Mbps full-duplex capable 0 = No 100 Mbps full-duplex capability	RW	1
4.7	100BASE-TX Half-Duplex	1 = 100 Mbps half-duplex capable 0 = No 100 Mbps half-duplex capability	RW	1

# KSZ8061RNB/RND

**TABLE 4-3: STANDARD REGISTER DESCRIPTION (CONTINUED)**

Address	Name	Description	Mode (Note 4-1)	Default
4.6	100BASE-TX Full-Duplex	1 = Capable of 10 Mbps half-duplex 0 = Not capable of 10 Mbps half-duplex	RW	1
4.5	100BASE-TX Half-Duplex	1 = Capable of 10 Mbps half-duplex 0 = Not capable of 10 Mbps half-duplex	RW	1
4.4:0	Selector Field	[00001] = IEEE 802.3	RW	0_0001
<b>Register 5h - Auto-Negotiation Link Partner Ability</b>				
5.15	Next Page	1 = Next page capable 0 = No next page capability	RO	0
5.14	Acknowledge	1 = Link code word received from partner 0 = Link code word not yet received	RO	0
5.13	Remove Fault	1 = Remote fault detected 0 = No remote fault	RO	0
5.12	Reserved	—	RO	0
5.11:10	Pause	[00] = No PAUSE [10] = Asymmetric PAUSE [01] = Symmetric PAUSE [11] = Asymmetric & Symmetric PAUSE	RO	00
5.9	100BASE-T4	1 = T4 capable 0 = No T4 capability	RO	0
5.8	100BASE-TX Full-Duplex	1 = 100 Mbps full-duplex capable 0 = No 100 Mbps full-duplex capability	RO	0
5.7	100BASE-TX Half-Duplex	1 = 100 Mbps half-duplex capable 0 = No 100 Mbps half-duplex capability	RO	0
5.6	10BASE-TX Full-Duplex	1 = 10 Mbps full-duplex capable 0 = No 10 Mbps full-duplex capability	RO	0
5.5	10BASE-TX Half-Duplex	1 = 10 Mbps half-duplex capable 0 = No 10 Mbps half-duplex capability	RO	0
5.4:0	Selector Field	[00001] = IEEE 802.3	RO	0_0001
<b>Register 6h - Auto-Negotiation Expansion</b>				
6.15:5	Reserved	—	RO	0000_0000_000
6.4	Parallel Detection Fault	1 = Fault detected by parallel detection 0 = No fault detected by parallel detection	RO/LH	0
6.3	Link Partner Next Page Able	1 = Link partner has next page capability 0 = Link partner does not have next page capability	RO	0
6.2	Next Page Able	1 = Local device has next page capability 0 = Local device does not have next page capability	RO	1
6.1	Page Received	1 = New page received 0 = New page not received yet	RO/LH	0
6.0	Link Partner Auto-Negotiation Able	1 = Link partner has auto-negotiation capability 0 = Link partner does not have auto-negotiation capability	RO	0
<b>Register 7h - Auto-Negotiation Next Page</b>				
7.15	Next Page	1 = Additional Next Page(s) will follow 0 = Last page	RW	0
7.14	Reserved	—	RO	0

**TABLE 4-3: STANDARD REGISTER DESCRIPTION (CONTINUED)**

Address	Name	Description	Mode (Note 4-1)	Default
7.13	Message Page	1 = Message page 0 = Unformatted page	RW	1
7.12	Acknowledge2	1 = Will comply with message 0 = Cannot comply with message	RW	0
7.11	Toggle	1 = Previous value of the transmitted link code word equal to logic one 0 = Logic zero	RO	0
7.10:0	Message Field	11-bit wide field to encode 2048 messages	RW	000_0000_0001
<b>Register 8h - Link Partner Next Page Ability</b>				
8.15	Next Page	1 = Additional Next Page(s) will follow 0 = Last page	RO	0
8.14	Acknowledge	1 = Successful receipt of link word 0 = No successful receipt of link word	RO	0
8.13	Message Page	1 = Message page 0 = Unformatted page	RO	0
8.12	Acknowledge2	1 = Able to act on the information 0 = Not able to act on the information	RO	0
8.11	Toggle	1 = Previous value of transmitted link code word equal to logic zero 0 = Previous value of transmitted link code word equal to logic one	RO	0
8.10:0	Message Field	—	RO	000_0000_0000
<b>Register Dh - MMD Access Control Register</b>				
D.15:14	Function	00 = address 01 = data, no post increment 10 = data, post increment on reads and writes 11 = data, post increment on writes only	RW	00
D.13:5	Reserved	Write as 0, ignore on read	RW	00_0000_000
D.4:0	DEVAD	Device address	RW	0_0000
<b>Register Eh - MMD Access Address Data Register</b>				
E.15:0	Address Data	If D.15:14 = 00, this is MMD DEVAD's address register. Otherwise, this is MMD DEVAD's data register as indicated by the contents of its address register.	RW	0000_0000_0000_00 00
<b>Register 10h - Digital Control Register</b>				
10.15:5	Reserved	—	RW	0000_0000_000
10.4	PLL off in EDPD Mode	This mode may optionally be combined with EDPD mode for additional power reduction. 1 = PLL is off in EDPD mode 0 = PLL is on in EDPD mode	RW	0
10.3:0	Reserved	—	RW	0000
<b>Register 11h - AFE Control 0 Register</b>				
11.15:7	Reserved	—	RW	0000_0000_0

# KSZ8061RNB/RND

**TABLE 4-3: STANDARD REGISTER DESCRIPTION (CONTINUED)**

Address	Name	Description	Mode (Note 4-1)	Default
11.6	Slow Oscillator Mode	This mode substitutes the 25-MHz clock with a slow oscillator clock, to save oscillator power during power down. 1 = Slow Oscillator mode enabled 0 = Slow Oscillator mode disabled	RW	0
11.5:0	Reserved	—	RW	00_0000
<b>Register 12h - AFE Control 1 Register (Note 4-2)</b>				
12.15:12	100BT amplitude	Trim 100BT TX amplitude Sequence of values: 1000 = maximum amplitude 1001 1010 1011 1100 1101 1110 1111 0000 = default 0001 0010 0011 0100 0101 0110 0111 = minimum amplitude	RW	0000
12.11:0	Reserved	—	RW	0000_0000_0000
<b>Register 13h - AFE Control 2 Register</b>				
13.15	LinkMD Detector Threshold	Sets the threshold for the LinkMD pulse detector. Use high threshold with the large LinkMD pulse, and the low threshold with the small LinkMD pulse. Also see MMD address 1Bh, register 0h bits [7:4]. 1 = Enable high threshold comparator 0 = Disable high threshold comparator	RW	0
13.14:1	Reserved	—	RW	000_0000_0000_000
13.0	Slow Oscillator Mode for Ultra-Deep Sleep mode	This mode substitutes the 25 MHz clock with a slow oscillator clock, to save oscillator power if register access is required during Ultra-Deep Sleep mode. Note that the 1.2V supply is required if this mode is used. 1 = Slow Oscillator mode enabled 0 = Slow Oscillator mode disable	RW	0
<b>Register 14h - AFE Control Register 3</b>				
14.15:7	Reserved	—	RW	0000_0000_0
14.6	Ultra-Deep Sleep method	1 = CPU Control method. Entry into Ultra-Deep Sleep mode determined by value of register bit 14.5 0 = Automatic method. Enter into Ultra-Deep Sleep mode automatically when no cable energy is detected	RW	0

**TABLE 4-3: STANDARD REGISTER DESCRIPTION (CONTINUED)**

Address	Name	Description	Mode (Note 4-1)	Default
14.5	Manual Ultra-Deep Sleep mode	1 = Enter into Standby mode 0 = Normal mode This bit is used to enter Ultra-Deep Sleep mode when the CPU Control method is selected in bit 14.6. To exit Ultra-Deep Sleep mode, a hardware reset is required.	RW	0
14.4	NV Register Access	1 = Enable the non-volatile copy of register 14h and bits [9:8] and [1:0] of 13h. 0 = Disable access to non-volatile registers When Ultra-Deep Sleep mode is enabled, this bit must be set to 1.	RW	0
14.3	Ultra-Deep Sleep mode and SIGDET Enable	1 = Ultra-Deep Sleep mode is enabled (but not necessarily entered), and SIGDET indicates cable energy detected 0 = Ultra-Deep Sleep mode is disabled, and SIGDET output signal is forced true.	RW	0
14.2	Disable RX internal termination	1 = Disable RX internal termination 0 = Enable RX internal termination [Has no effect on TX internal termination.]	RW	0
14.1	Signal Detect deassertion timing delay	When Ultra-Deep Sleep mode is enabled, this bit determines the delay from loss of cable energy to deassertion of SIGDET. When automatic method is selected for Ultra-Deep Sleep mode, this delay also applies to powering down. 1 = Increased delay. This setting is required to allow automatic exiting of Ultra Deep Sleep mode (automatic method) if the link partner auto-negotiation is enabled, if auto-MDI/MDI-X is enabled, or if linking at 10BASE-T. 0 = Minimum delay. When using the Automatic method for Ultra-Deep Sleep mode, use this setting only if the link partner's auto-negotiation is disabled, auto-MDI/MDI-X is disabled, and linking is at 100BASE-TX. This setting may also be used for CPU Control method.	RW	0
14.0	Signal Detect polarity	1 = SIGDET is active low (low = signal detected) 0 = SIGDET is active high (high = signal detected)	RW	0
<b>Register 15h - RXER Counter</b>				
15.15:0	RXER Counter	Receive error counter for symbol error frames	RO/SC	0000h
<b>Register 16h - Operation Mode</b>				
16.15:13	Reserved	—	RW	000
16.12	QWF disable	1 = Disable Quiet-Wire Filtering 0 = Enable Quiet-Wire Filtering Quiet-Wire filtering can be disabled by setting this bit. However, it cannot be enabled by clearing this bit to 0.	RW	Strapping input at RXER pin

# KSZ8061RNB/RND

**TABLE 4-3: STANDARD REGISTER DESCRIPTION (CONTINUED)**

Address	Name	Description	Mode (Note 4-1)	Default
16.11:0	Reserved	—	RW	0000_0000_0000
<b>Register 17h - Operation Mode Strap Status</b>				
17.15:13	PHYAD[2:0] strap-in status	[000] = Strap to PHY Address 0 [001] = Strap to PHY Address 1 [010] = Strap to PHY Address 2 [011] = Strap to PHY Address 3 [100] = Strap to PHY Address 4 [101] = Strap to PHY Address 5 [110] = Strap to PHY Address 6 [111] = Strap to PHY Address 7	RO	—
17.12:9	Reserved	—	RO	—
17.8	QWF strap-in status	1 = Strap to enable Quiet-Wire Filtering	RO	—
17.7	Reserved	—	RO	0
17.6	RMII B-to-B strap-in status	1 = Strap to RMII Back-to-Back mode	RO	—
17.5	NAND Tree strap-in status	1 = Strap to NAND Tree mode	RO	—
17.4:2	Reserved	—	RO	0
17.1	RMII strap-in status	1 = Strap to RMII normal mode	RO	—
17.0	Reserved	—	RO	0
<b>Register 18h - Expanded Control</b>				
18.15:12	Reserved	—	RW	0000
18.11	Energy Detect Power Down Mode disable	1 = Disable Energy Detect Power Down (EDPD) mode 0 = Enable EDPD mode	RW	1
18.10	RX PHY Latency	1 = Variable RX PHY latency with no preamble suppression 0 = Fixed RX PHY latency with possible suppression of one preamble nibble. There is an 80% chance of this happening on the first packet received after link-up. The loss is seen at the RMII interface. Preamble suppression cannot occur again until after the next link-up.	RW	0
18.9:7	Reserved	—	RW	00_0
18.6	Enable 10BT Preamble	When in Back-to-Back mode and in 10BASE-T, this bit must be set.	RW	0
18.5:0	Reserved	—	RW	00_0001
<b>Register 1Bh - Interrupt Control/Status</b>				
1B.15	Jabber Interrupt Enable	1 = Enable Jabber Interrupt 0 = Disable Jabber Interrupt	RW	0
1B.14	Receive Error Interrupt Enable	1 = Enable Receive Error Interrupt 0 = Disable Receive Error Interrupt	RW	0
1B.13	Page Received Interrupt Enable	1 = Enable Page Received Interrupt 0 = Disable Page Received Interrupt	RW	0



**TABLE 4-3: STANDARD REGISTER DESCRIPTION (CONTINUED)**

Address	Name	Description	Mode (Note 4-1)	Default
1B.12	Parallel Detect Fault Interrupt Enable	1 = Enable Parallel Detect Fault Interrupt 0 = Disable Parallel Detect Fault Interrupt	RW	0
1B.11	Link Partner Acknowledge Interrupt Enable	1 = Enable Link Partner Acknowledge Interrupt 0 = Disable Link Partner Acknowledge Interrupt	RW	0
1B.10	Link Down Interrupt Enable	1 = Enable Link Down Interrupt 0 = Disable Link Down Interrupt	RW	0
1B.9	Remote Fault Interrupt Enable	1 = Enable Remote Fault Interrupt 0 = Disable Remote Fault Interrupt	RW	0
1B.8	Link Up Interrupt Enable	1 = Enable Link Up Interrupt 0 = Disable Link Up Interrupt	RW	0
1B.7	Jabber Interrupt	1 = Jabber occurred 0 = Jabber did not occurred	RO/SC	0
1B.6	Receive Error Interrupt	1 = Receive Error occurred 0 = Receive Error did not occurred	RO/SC	0
1B.5	Page Receive Interrupt	1 = Page Receive occurred 0 = Page Receive did not occur	RO/SC	0
1B.4	Parallel Detect Fault Interrupt	1 = Parallel Detect Fault occurred 0 = Parallel Detect Fault did not occur	RO/SC	0
1B.3	Link Partner Acknowledge Interrupt	1 = Link Partner Acknowledge occurred 0 = Link Partner Acknowledge did not occur	RO/SC	0
1B.2	Link Down Interrupt	1 = Link Down occurred 0 = Link Down did not occur	RO/SC	0
1B.1	Remote Fault Interrupt	1 = Remote Fault occurred 0 = Remote Fault did not occur	RO/SC	0
1B.0	Link Up Interrupt	1 = Link Up occurred 0 = Link Up did not occur	RO/SC	0
<b>Register 1Ch - Function Control</b>				
1C.15:6	Reserved	—	RW	0000_0000_00
1C.5	Local Loopback Option	1 = Enable local loopback 0 = Disable local loopback Local loopback must be enabled both here and in register 0h.	RW	0
1C.4:0	Reserved	—	RW	1_0000
<b>Register 1Dh - LinkMD® Control/Status</b>				
1D.15	Cable Diagnostic Test Enable	1 = Enable cable diagnostic test. After test has completed, this bit is self-cleared. 0 = Indicates cable diagnostic test (if enabled) has completed and the status information is valid for read.	RW/SC	0

# KSZ8061RNB/RND

**TABLE 4-3: STANDARD REGISTER DESCRIPTION (CONTINUED)**

Address	Name	Description	Mode (Note 4-1)	Default
1D.14:13	Cable Diagnostic Test Result	[00] = Normal condition [01] = Open condition has been detected in cable [10] = Short condition has been detected in cable [11] = Cable diagnostic test has failed	RO	00
1D.12	Short Cable Indicator	1 = Short cable (<10 meter) has been detected by LinkMD®.	RO	0
1D.11:9	Reserved	—	RW	000
1D.8:0	Cable Fault Counter	Distance to fault	RO	0_0000_0000
<b>Register 1Eh - PHY Control 1</b>				
1E.15:10	Reserved	—	RO	0000_00
1E.9	Enable Pause (Flow Control)	1 = Flow control capable 0 = No flow control capability	RO	0
1E.8	Link Status	1 = Link is up 0 = Link is down	RO	—
1E.7	Polarity Status	1 = Polarity is reversed 0 = Polarity is not reversed	RO	—
1E.6	Reserved	—	RO	0
1E.5	MDI/MDI-X State	1 = MDI-X 0 = MDI	RO	—
1E.4	Energy Detect	1 = Presence of signal on receive differential pair 0 = No signal detected on receive differential pair	RO	—
1E.3	PHY Isolate	1 = PHY in isolate mode 0 = PHY in normal operation [Same as register bit 0.10]	RW	0
1E.2:0	Operation Mode Indication	[000] = still in auto-negotiation [001] = 10BASE-T half-duplex [010] = 100BASE-TX half-duplex [011] = reserved [100] = reserved [101] = 10BASE-T full-duplex [110] = 100BASE-TX full-duplex [111] = reserved	RO	—
<b>Register 1Fh - PHY Control 2</b>				
1F.15	HP_MDIX	1 = HP Auto MDI/MDI-X mode 0 = Auto MDI/MDI-X mode	RW	1
1F.14	MDI/MDI-X Select	When Auto MDI/MDI-X is disabled, 1 = MDI-X mode Transmit on RXP,RXM, andReceive on TXP,TXM 0 = MDI mode Transmit on TXP,TXM andReceive on RXP,RXM	RW	0
1F.13	Pair Swap Disable	1 = Disable auto MDI/MDI-X 0 = Enable auto MDI/MDI-X	RW	Value determined by pin strapping option

**TABLE 4-3: STANDARD REGISTER DESCRIPTION (CONTINUED)**

Address	Name	Description	Mode (Note 4-1)	Default
1F.12	Reserved	—	RW	0
1F.11	Force Link	1 = Force link pass 0 = Normal link operation This bit bypasses the control logic and allow transmitter to send pattern even if there is no link. It does not cause a link-up condition to occur.	RW	0
1F.10	Power Saving	1 = Enable power saving 0 = Disable power saving	RW	0
1F.9	Interrupt Level	1 = Interrupt pin active high 0 = Interrupt pin active low	RW	0
1F.8	Enable Jabber	1 = Enable jabber counter 0 = Disable jabber counter	RW	1
1F.7:6	Reserved	—	RW	00
1F.5:4	LED Mode	[00] = LED1: Speed, LED0: Link / Activity [01] = LED1: Activity, LED0: Link [10] = reserved [11] = reserved	RW	00
1F.3	Disable Transmitter	1 = Disable transmitter 0 = Enable transmitter	RW	0
1F.2	Remote Loopback	1 = Remote (analog) loopback is enabled 0 = Normal mode	RW	0
1F.1	Enable SQE Test	1 = Enable SQE test 0 = Disable SQE test	RW	0
1F.0	Disable Data Scrambling	1 = Disable scrambler 0 = Enable scrambler	RW	0

**Note 4-1** RW = Read/Write  
RO = Read only  
SC = Self-cleared  
LH = Latch high  
LL = Latch low

**Note 4-2** If necessary, the value of this register can be used to adjust the transmit amplitude to achieve IEEE 802.3 Transmit Waveform Mask compliance. Increasing the register value decreases the TX amplitude, and decreasing the register value increases the TX amplitude.

## 4.2 MMD Registers

MMD registers provide indirect read/write access to up to 32 MMD Device Addresses with each device supporting up to 65,536 16-bit registers, as defined in clause 22 of the IEEE 802.3 Specification. The KSZ8061RNB/RND, however, uses only a small fraction of the available registers. See [Section 4.0, "Register Map"](#) for a list of supported MMD device addresses and their associated register addresses.

The following two standard registers serve as the portal registers to access the indirect MMD registers.

- Standard register Dh - MMD Access - Control
- Standard register Eh - MMD Access - Register/Data

# KSZ8061RNB/RND

**TABLE 4-4: MMD REGISTERS**

Address	Name	Description	Mode	Default
<b>Register Dh - MMD Access Control Register</b>				
D.15:14	Function	00 = address 01 = data, no post increment 10 = data, post increment on reads and writes 11 = data, post increment on writes only	RW	00
D.13:5	Reserved	Write as 0, ignore on read	RW	00_0000_000
D.4:0	DEVAD	These five bits set the MMD device address	RW	0_0000
<b>Register Eh - MMD Access Address Data Register</b>				
E.15:0	Address/Data	When register Dh, bits [15:14] = 00, this register contains the MMD DEVAD's address register. Otherwise, this register contains the MMD DEVAD's data register as indicated by the contents of its address register.	RW	0000_0000_0

Examples:

**MMD Register Write**

Write MMD - Device Address 7h, Register 3Ch = 0002h.

1. Write Register Dh with 0007h // Set up register address for MMD - Device Address 7h.
2. Write Register Eh with 003Ch // Select register 3Ch of MMD - Device Address 7h.
3. Write Register Dh with 4007h // Select register data for MMD - Device Address 7h, Register 3Ch.
4. Write Register Eh with 0002h // Write value 0002h to MMD - Device Address 7h, Register 3Ch.

**MMD Register Read**

Read MMD - Device Address 1Fh, Register 19h - 1Bh.

1. Write Register Dh with 001Fh // Set up register address for MMD - Device Address 1Fh.
2. Write Register Eh with 0019h // Select register 19h of MMD - Device Address 1Fh.
3. Write Register Dh with 801Fh // Select register data for MMD - Device Address 1Fh, Register 19h  
// with post increments.
4. Read Register Eh // Read data in MMD - Device Address 1Fh, Register 19h.
5. Read Register Eh // Read data in MMD - Device Address 1Fh, Register 1Ah.
6. Read Register Eh // Read data in MMD - Device Address 1Fh, Register 1Bh.

**TABLE 4-5: MMD REGISTERS**

Address	Name	Description	Mode	Default
<b>MMD Address 7h, Register 3Ch - Reserved</b>				
7.3C.15:8	Reserved	Reserved	RW	0
7.3C.7:3	Reserved	Reserved	RW	0
7.3C.2	Reserved	Reserved	RW	0
7.3C.1	Reserved	Reserved	RW	0
7.3C.0	Reserved	Reserved	RW	0
<b>MMD Address 7h, Register 3Dh - Reserved</b>				
7.3D.15:3	Reserved	Reserved	RO	0
7.3D.2	Reserved	Reserved	RO	0
7.3D.1	Reserved	Reserved	RO	0
7.3D.0	Reserved	Reserved	RO	0
<b>MMD Address 1Bh, Register 0h - AFED Control Register</b>				
1B.0.15:8	Reserved	Reserved	RW	0000_0000
1B.0.7:4	LinkMD Pulse Amplitude	Sets the amplitude of the LinkMD pulse. Default value (0x2) is a small pulse. Set to 0x7 for a large pulse. Also see register 13h bit [15].	RW	0010
1B.0.3:0	Reserved	Reserved	RW	0000
<b>MMD Address 1Ch, Register ACh - Signal Quality Register</b>				
1C.AC.15	Reserved	Reserved	RO	
1C.AC.14:8	Signal Quality Indicator	SQI indicates relative quality of the signal. A lower value indicates better signal quality.	RO	
1C.AC.7:0	Reserved	Reserved	RO	

# KSZ8061RNB/RND

---

## 5.0 OPERATIONAL CHARACTERISTICS

### 5.1 Absolute Maximum Ratings\*

Supply Voltage (VDDIO, AVDDH) .....	-0.5V to +5.0V
(VDDL, AVDDL).....	-0.5V to +1.8V
Input Voltage (all inputs).....	-0.5V to +5.0V
Output Voltage (all inputs).....	-0.5V to +5.0V
Lead Temperature (soldering, 10sec.).....	+260°C
Storage Temperature (T <sub>S</sub> ).....	-55°C to +150°C
Lead Temperature Range.....	Refer to JEDEC Spec. J-STD-020
HBM ESD Rating.....	5 kV

\* Exceeding the absolute maximum rating may damage the device. Stresses greater than the absolute maximum rating may cause permanent damage to the device. Operation of the device at these or any other conditions above those specified in the operating sections of this specification is not implied. Maximum conditions for extended periods may affect reliability.

### 5.2 Operating Conditions\*\*

#### Supply Voltage

(AVDDH @ 3.3V).....	+3.135V to +3.465V
(VDDIO @ 3.3V).....	+3.135V to +3.465V
(VDDIO @ 2.5V).....	+2.375V to +2.625V
(VDDL, AVDDL).....	+1.14V to +1.26V

#### Ambient Temperature

(T <sub>A</sub> , Industrial).....	-40°C to +85°C
(T <sub>A</sub> , Extended).....	-40°C to +105°C
Maximum Junction Temperature (T <sub>J</sub> max).....	+125°C
Thermal Resistance (Θ <sub>JA</sub> , 32-QFN, 32-WQFN) .....	34°C/W
Thermal Resistance (Θ <sub>JC</sub> , 32-QFN, 32-WQFN) .....	6°C/W

\*\* The device is not guaranteed to function outside its operating ratings.

## 6.0 ELECTRICAL CHARACTERISTICS

$T_A = 25^\circ\text{C}$ , bold values indicate  $-40^\circ\text{C} \leq T_A \leq +85^\circ\text{C}$ , unless noted.

**TABLE 6-1: ELECTRICAL CHARACTERISTICS**

Symbol	Parameter	Condition	Min.	Typ.	Max.	Units
<b>Supply Current for VDDL, AVDDL</b>						
$I_{\text{CORE}}$	1.2V Current for VDDL + AVDDL	No link, attempting to auto-negotiate	—	59	—	mA
		100BASE-TX full-duplex at 100% utilization	—	45	—	
		100BASE-TX link up, no traffic	—	45	—	
		10BASE-T full-duplex at 100% utilization	—	17	—	
		10BASE-T link up, no traffic	—	17	—	
		Energy Detect Power Down (EDPD) mode, no link partner (reg. 18h.11 = 0)	—	16	—	
		EDPD mode with PLL off, no link partner (reg. 18h.11 = 0; reg. 10h.4 = 1)	—	0.7	—	
		Power Down mode (reg. 0h.11 = 1)	—	0.5	—	
		Power Down mode, MII isolate, slow oscillator mode (reg. 0h.11 = 1; reg. 0h.10 = 1; reg. 11h.6 = 1)	—	0.05	—	
		Ultra-Deep Sleep mode with 1.2V (reg. 14h = 0x0078)	—	46	—	$\mu\text{A}$
		Ultra-Deep Sleep mode, VDDL and AVDDL = 0V (reg. 14h = 0x0078)	—	0	—	
		$I_{\text{VDDIO}_2.5}$	2.5V Current for Digital I/Os	No link, attempting to auto-negotiate	—	3.3
100BASE-TX full-duplex at 100% utilization	—			5.9	—	
100BASE-TX link up, no traffic	—			3.3	—	
10BASE-T full-duplex at 100% utilization	—			1.0	—	
10BASE-T link up, no traffic	—			0.6	—	
Energy Detect Power Down (EDPD) mode, no link partner (reg. 18h.11 = 0)	—			3.9	—	
EDPD mode with PLL off, no link partner (reg. 18h.11 = 0; reg. 10h.4 = 1)	—			0.23	—	
Power Down mode (reg. 0h.11 = 1)	—			0.23	—	
Power Down mode, MII isolate, slow oscillator mode (reg. 0h.11 = 1; reg. 0h.10 = 1; reg. 11h.6 = 1)	—			0.10	—	
Ultra-Deep Sleep mode with 1.2V (reg. 14h = 0x0078)	—			100	—	$\mu\text{A}$
Ultra-Deep Sleep mode, VDDL and AVDDL = 0V (reg. 14h = 0x0078)	—			0.01	—	

# KSZ8061RNB/RND

**TABLE 6-1: ELECTRICAL CHARACTERISTICS (CONTINUED)**

Symbol	Parameter	Condition	Min.	Typ.	Max.	Units
I <sub>VDDIO_3.3</sub>	3.3V Current for Digital I/Os	No link, attempting to auto-negotiate	—	6.5	—	mA
		100BASE-TX full-duplex at 100% utilization	—	11	—	
		100BASE-TX link up, no traffic	—	6.5	—	
		10BASE-T full-duplex at 100% utilization	—	1.7	—	
		10BASE-T link up, no traffic	—	1.1	—	
		Energy Detect Power Down (EDPD) mode, no link partner (reg. 18h.11 = 0)	—	6.6	—	
		EDPD mode with PLL off, no link partner (reg. 18h.11 = 0; reg. 10h.4 = 1)	—	0.56	—	
		Power Down mode (reg. 0h.11 = 1)	—	0.51	—	
		Power Down mode, MII isolate, slow oscillator mode (reg. 0h.11 = 1; reg. 0h.10 = 1; reg. 11h.6 = 1)	—	0.18	—	
		Ultra-Deep Sleep mode with 1.2V (reg. 14h = 0x0078)	—	180	—	μA
Ultra-Deep Sleep mode, VDDL and AVDDL = 0V (reg. 14h = 0x0078)	—	0.01	—			
<b>Supply Current for AVDDH</b>						
I <sub>AVDDH_3.3</sub>	3.3V Current for Transceiver	No link, attempting to auto-negotiate	—	19	—	mA
		100BASE-TX full-duplex at 100% utilization	—	24	—	
		100BASE-TX link up, no traffic	—	24	—	
		10BASE-T full-duplex at 100% utilization	—	28	—	
		10BASE-T link up, no traffic	—	16	—	
		Energy Detect Power Down (EDPD) mode, no link partner (reg. 18h.11 = 0)	—	4.3	—	
		EDPD mode with PLL off, no link partner (reg. 18h.11 = 0; reg. 10h.4 = 1)	—	2.2	—	
		Power Down mode (reg. 0h.11 = 1)	—	10	—	
		Power Down mode, MII isolate, slow oscillator mode (reg. 0h.11 = 1; reg. 0h.10 = 1; reg. 11h.6 = 1)	—	0.18	—	
		Ultra-Deep Sleep mode with 1.2V (reg. 14h = 0x0078)	—	0.5	—	μA
Ultra-Deep Sleep mode, VDDL and AVDDL = 0V (reg. 14h = 0x0078)	—	0.4	—			
<b>CMOS Inputs (MDC, RESET, TXD, TXEN, TXER)</b>						
V <sub>IH</sub>	Input High Voltage	VDDIO = 3.3V	2.0	—	—	V
		VDDIO = 2.5V	1.5	—	—	
V <sub>IL</sub>	Input Low Voltage	VDDIO = 3.3V	—	—	1.3	V
		VDDIO = 2.5V	—	—	1.0	
I <sub>IN</sub>	Input Current	V <sub>IN</sub> = GND ~ VDDIO	—	—	10	μA
<b>CMOS Outputs (COL, CRS, LED, RXC, RXD, RXDV, RXER, SIGDET, TXC)</b>						
V <sub>OH</sub>	Output High Voltage	VDDIO = 3.3V, I <sub>OH</sub> = 12 mA	2.4	—	—	V
		VDDIO = 2.5V, I <sub>OH</sub> = 6 mA	2.0	—	—	
V <sub>OL</sub>	Output Low Voltage	VDDIO = 3.3V, I <sub>OL</sub> = 6 mA	—	—	0.4	V
		VDDIO = 2.5V, I <sub>OL</sub> = 5 mA	—	—	0.4	



# KSZ8061RNB/RND

**TABLE 6-1: ELECTRICAL CHARACTERISTICS (CONTINUED)**

Symbol	Parameter	Condition	Min.	Typ.	Max.	Units
$ I_{OZ} $	Output Tri-State Leakage	$V_{OUT} = GND \sim VDDIO$	—	—	10	$\mu A$
<b>All Pull-Up/Pull-Down Pins (including Strapping Pins)</b>						
pu	Internal Pull-Up Resistance	VDDIO = 3.3V, external 4.7-k $\Omega$ pull-down	—	33	—	k $\Omega$
		VDDIO = 2.5V, external 4.7-k $\Omega$ pull-down	—	47	—	
pd	Internal Pull-Down Resistance	VDDIO = 3.3V, external 4.7-k $\Omega$ pull-up	—	36	—	k $\Omega$
		VDDIO = 2.5V, external 4.7-k $\Omega$ pull-up	—	48	—	
<b>100BASE-TX Transmit (measured differentially after 1:1 transformer)</b>						
$V_O$	Peak Differential Output Voltage	100 $\Omega$ termination across differential output	0.95	—	1.05	V
$V_{IMB}$	Output Voltage Imbalance	100 $\Omega$ termination across differential output	—	—	2	%
$t_r/t_f$	Rise/Fall Time	—	3	—	5	ns
—	Rise/Fall Time Imbalance	—	0	—	0.5	
—	Duty Cycle Distortion	—	—	—	$\pm 0.25$	
—	Overshoot	—	—	—	5	%
—	Output Jitter	Peak-to-peak	—	0.7	—	ns
<b>10BASE-T Transmit (measured differentially after 1:1 transformer)</b>						
$V_P$	Peak Differential Output Voltage	100 $\Omega$ termination across differential output	2.2	—	2.8	V
—	Jitter Added	Peak-to-peak	—	—	3.5	ns
$t_r/t_f$	Rise/Fall Time	—	—	25	—	
<b>10BASE-T Receive</b>						
$V_{SQ}$	Squelch Threshold	5 MHz square wave	—	400	—	mV
<b>100 Mbps Mode - Industrial Applications Parameters</b>						
$t_{lir}$	Link Loss Reaction (Indication) Time	Link loss detected at receive differential inputs to PHY signal indication time for each of the following: 1. For LED mode "01", Link LED output change from low (link-up) to high (link-down). 2. INTRP pin assertion for link-down status change.	—	4.8	—	$\mu s$

# KSZ8061RNB/RND

## 7.0 TIMING DIAGRAMS

### 7.1 RMII Timing

**FIGURE 7-1: RMII TRANSMIT TIMING**

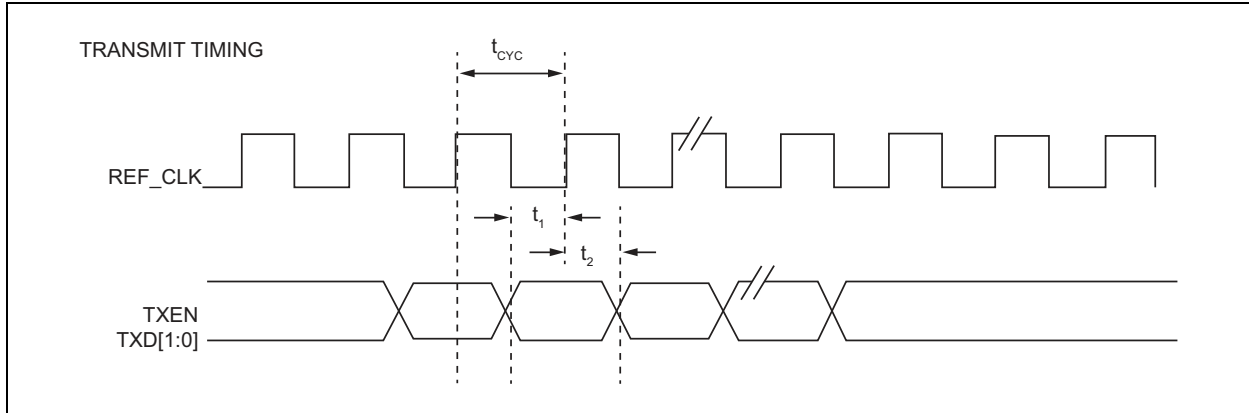

**FIGURE 7-2: RMII RECEIVE TIMING**

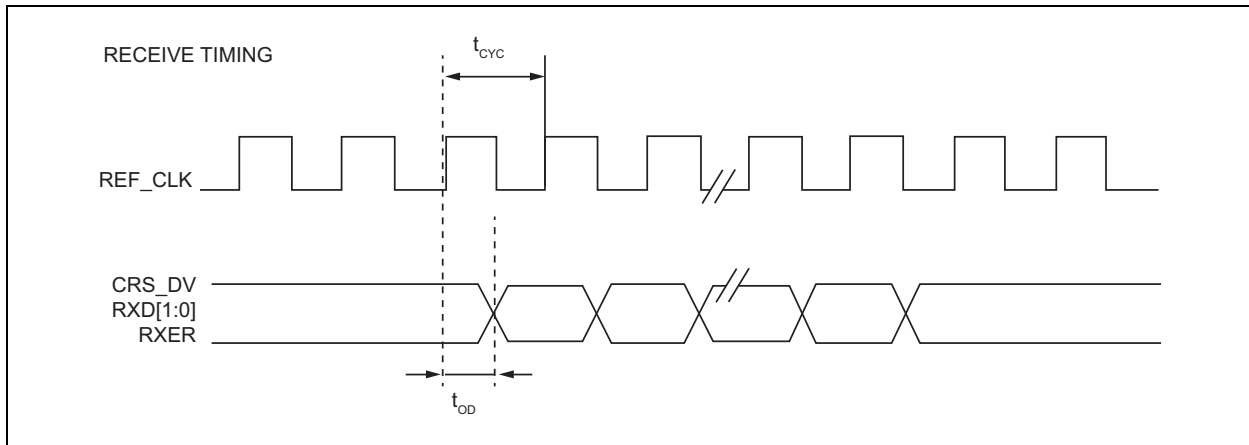
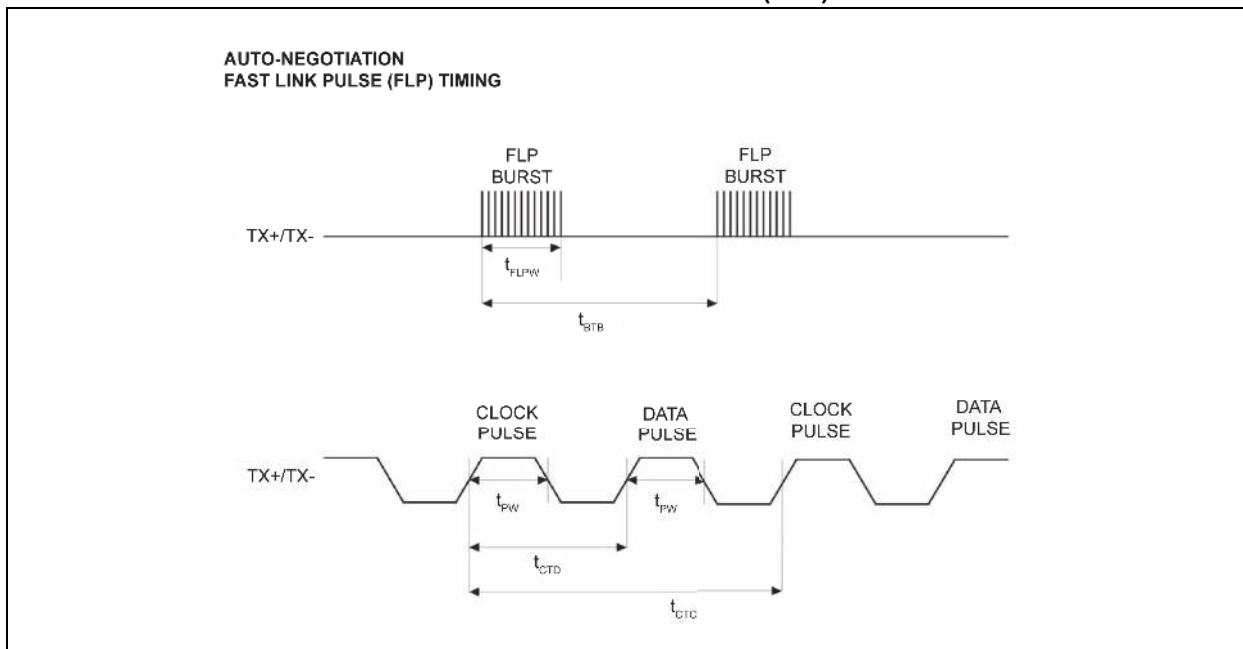

**TABLE 7-1: RMII TIMING PARAMETERS**

Timing Parameter	Description	Min.	Typ.	Max.	Units
$t_{cyc}$	Clock period	—	20	—	ns
$t_1$	Setup time	4	—	—	
$t_2$	Hold time	2	—	—	
$t_{OD}$	Output delay	7	10	13	

## 7.2 Auto-Negotiation Timing

**FIGURE 7-3: AUTO-NEGOTIATION FAST LINK PULSE (FLP) TIMING**



**TABLE 7-2: AUTO-NEGOTIATION FAST LINK PULSE (FLP) TIMING**

Timing Parameter	Description	Min.	Typ.	Max.	Units
$t_{BTB}$	FLP Burst to FLP Burst	8	16	24	ms
$t_{PLPW}$	FLP Burst width	—	2	—	ms
$t_{PW}$	Clock/Data Pulse width	—	100	—	ns
$t_{CTD}$	Clock Pulse to Data Pulse	55.5	64	69.5	$\mu$ s
$t_{CTC}$	Clock Pulse to Clock Pulse	111	128	139	$\mu$ s
—	Number of Clock/Data Pulse per FLP Burst	17	—	33	—

# KSZ8061RNB/RND

## 7.3 MDC/MDIO Timing

FIGURE 7-4: MDC/MDIO TIMING

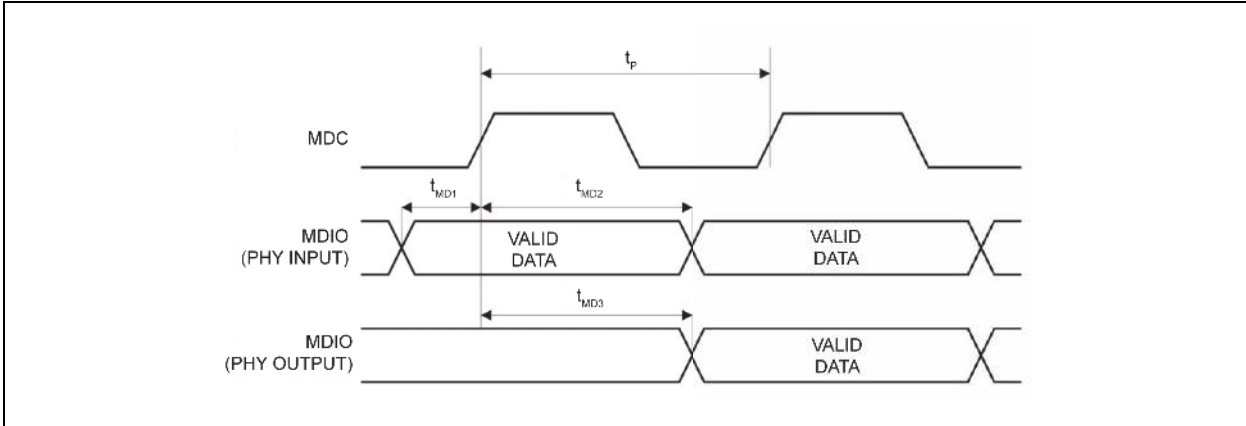

TABLE 7-3: MDC/MDIO TIMING PARAMETERS

Timing Parameter	Description	Min.	Typ.	Max.	Units
$t_p$	MDC period	400	—	—	ns
$t_{MD1}$	MDIO (PHY input) setup to rising edge of MDC	10	—	—	
$t_{MD2}$	MDIO (PHY input) hold from rising edge of MDC	4	—	—	
$t_{MD3}$	MDIO (PHY output) delay from rising edge of MDC	5	—	—	

## 7.4 Power-up/Reset Timing

The KSZ8061RNB/RND reset timing requirement is summarized in [Figure 7-5](#) and [Figure 7-4](#).

**FIGURE 7-5: POWER-UP/RESET TIMING**

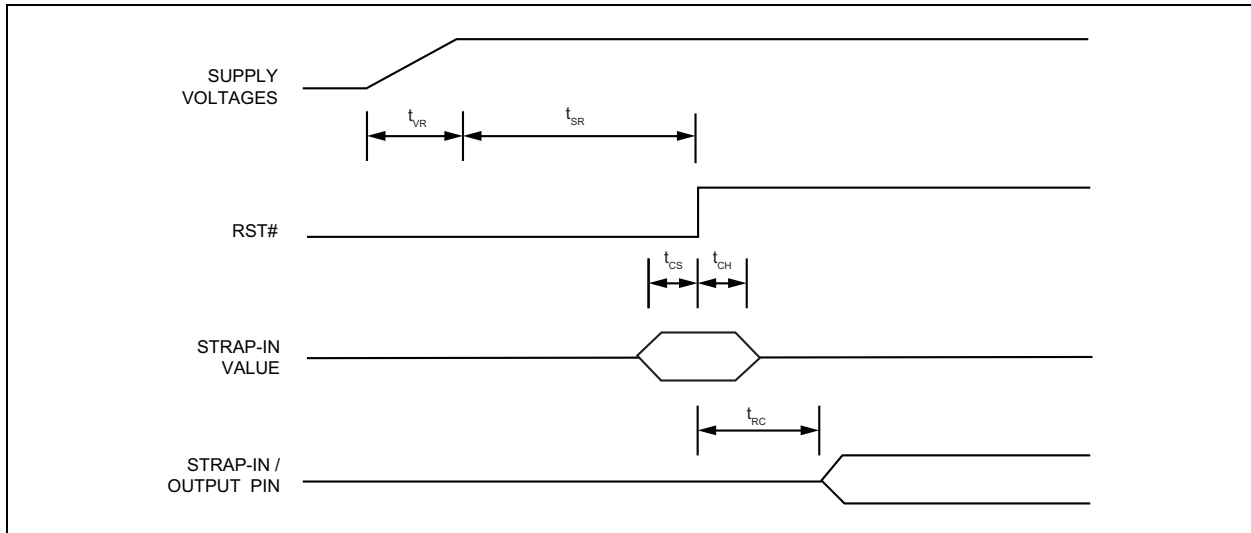

**TABLE 7-4: POWER-UP/RESET TIMING PARAMETERS**

Parameter	Description	Min.	Typ.	Max.	Units
$t_{vr}$	Supply voltage (VDDIO, AVDD, VDDL, AVDDL) rise time	300	—	—	$\mu\text{s}$
$t_{sr}$	Stable supply voltage (VDDIO, AVDD, VDDL, AVDDL) to reset high	10	—	—	ms
$t_{cs}$	Configuration setup time	5	—	—	ns
$t_{ch}$	Configuration hold time	5	—	—	ns
$t_{rc}$	Reset to strap-in pin output	6	—	—	ns

The supply voltage (VDDIO, AVDD, VDDL, AVDDL) power-up waveforms should be monotonic, and the 300  $\mu\text{s}$  minimum rise time is from 10% to 90%.

For warm reset, the reset (RESET#) pin should be asserted low for a minimum of 500  $\mu\text{s}$ . The strap-in pin values are read and updated at the deassertion of reset.

After the deassertion of reset, it is recommended to wait a minimum of 100  $\mu\text{s}$  before starting programming on the MIIM (MDC/MDIO) Interface.

# KSZ8061RNB/RND

## 8.0 RESET CIRCUIT

Figure 8-1 shows a reset circuit recommended for powering up the KSZ8061RNB/RND if reset is triggered by the power supply.

**FIGURE 8-1: RECOMMENDED RESET CIRCUIT**

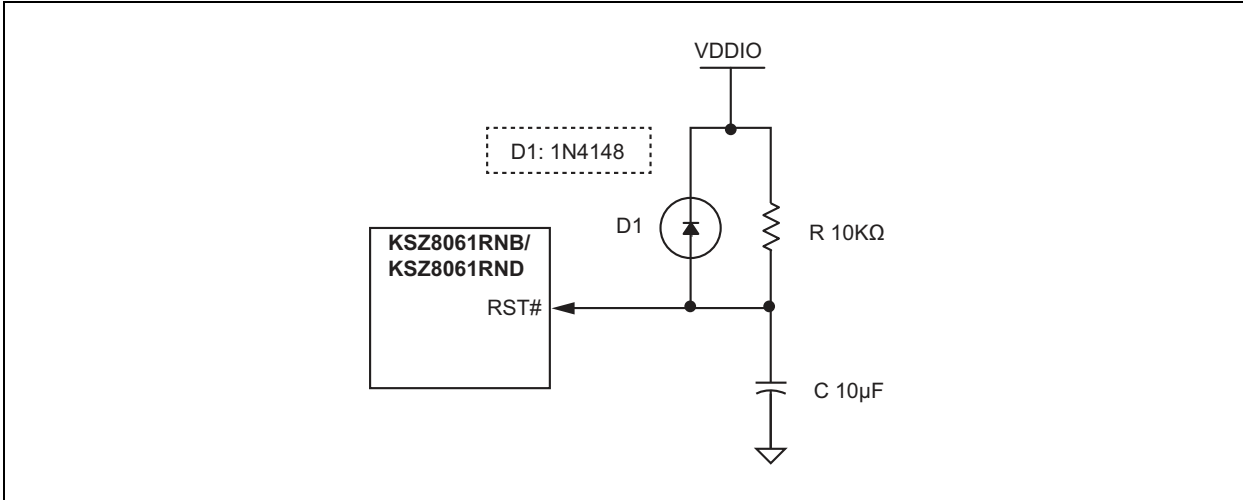
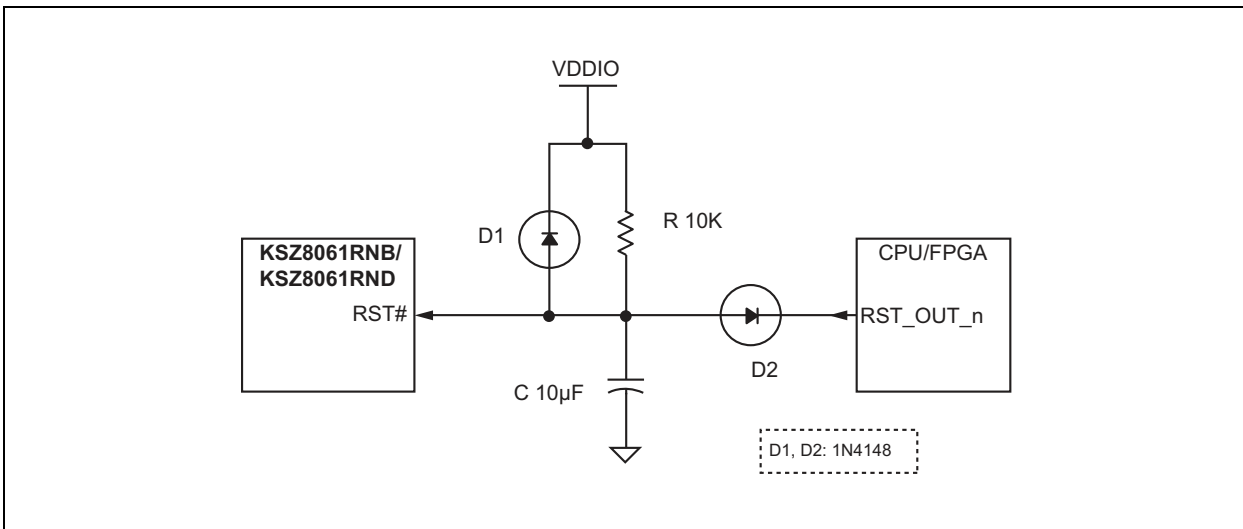

Figure 8-2 represents a reset circuit recommended for applications where reset is driven by another device (for example, CPU or FPGA). At power-on-reset, R, C, and D1 provide the necessary ramp rise time to reset the KSZ8061RNB/RND. The RST\_OUT\_n from CPU/FPGA provides the warm reset after power up.

**FIGURE 8-2: RECOMMENDED RESET CIRCUIT FOR INTERFACING WITH CPU/FPGA RESET OUTPUT**



## 9.0 REFERENCE CLOCK CONNECTION AND SELECTION - KSZ8061RNB

A crystal or external clock source, such as an oscillator, is used to provide the reference clock for the KSZ8061RNB. For the KSZ8061RNB in all operating modes, the reference clock is 25 MHz. An oscillator should be powered by the same voltage as AVDDH (3.3V). The reference clock connections to XI (pin 1) and XO (pin 2), and the reference clock selection criteria are provided in [Figure 9-1](#) and [Table 9-1](#).

The KSZ8061RNB outputs a 50-MHz RMI reference clock on the REF\_CLK pin.

**FIGURE 9-1: KSZ8061RNB 25-MHZ CRYSTAL/OSCILLATOR REFERENCE CLOCK CONNECTION**

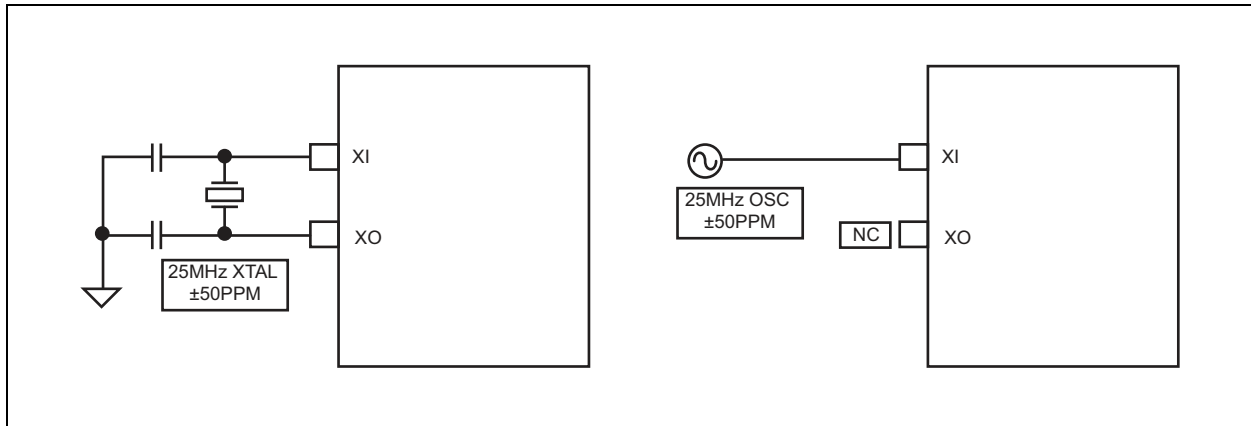

**TABLE 9-1: 25 MHz CRYSTAL/REFERENCE CLOCK SELECTION CRITERIA**

Characteristics	Value	Units
Frequency	25	MHz
Frequency Tolerance (Max.)	±50	ppm
Crystal Drive Level	150	µW

**TABLE 9-2: RECOMMENDED CRYSTALS**

Manufacturer	Part Number
NDK	NX2016SA
Murata	XRCGB25M000F3A00R0

# KSZ8061RNB/RND

---

## 10.0 REFERENCE CLOCK CONNECTION - KSZ8061RND

The KSZ8061RND uses a 50-MHz RMI reference clock input for all of its timing. The 50-MHz clock connects to the XI pin as shown in [Figure 10-1](#). The clock should be at the same voltage as AVDDH (3.3V). The XO and REF\_CLK pins are unconnected.

**FIGURE 10-1: KSZ8061RND 50-MHZ CLOCK CONNECTION**

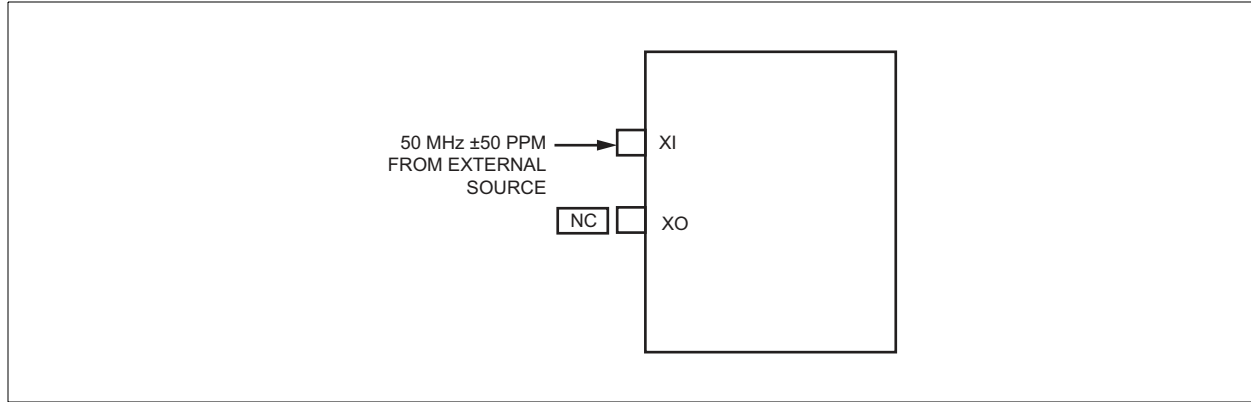



## 11.0 MAGNETIC – CONNECTION AND SELECTION

The KSZ8061RNB/RND design incorporates voltage-mode transmit drivers and on-chip terminations.

With the voltage-mode implementation, the transmit drivers supply the common-mode voltages to the two differential pairs. Therefore, the two transformer center tap pins on the KSZ8061RNB/RND side should not be connected to any power supply source on the board. Instead, the center tap pins should be separated from one another and connected through separate 0.1  $\mu$ F common-mode capacitors to ground. Separation is required because the common-mode voltage is different between transmitting and receiving differential pairs.

Figure 11-1 shows the typical magnetic interface circuit for the KSZ8061RNB/RND.

**FIGURE 11-1: TYPICAL MAGNETIC INTERFACE CIRCUIT**

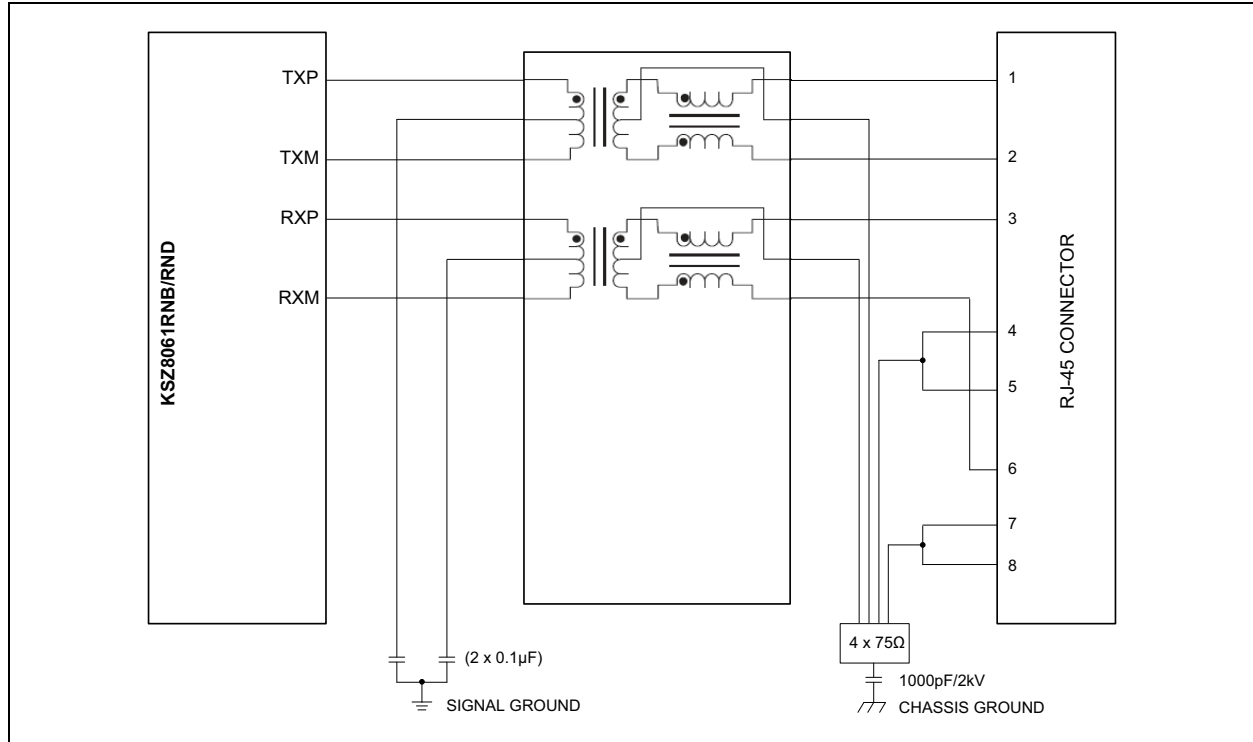

Table 11-1 lists recommended magnetic characteristics.

**TABLE 11-1: MAGNETICS SELECTION CRITERIA**

Parameter	Value	Test Condition
Turns ratio	1 CT : 1 CT	—
Open-circuit inductance (minimum)	350 $\mu$ H	100 mV, 100 kHz, 8 mA
Insertion loss (typical)	-1.1 dB	100 kHz to 100 MHz
HIPOT (minimum)	1500 V <sub>rms</sub>	—

# KSZ8061RNB/RND

## 12.0 PACKAGE OUTLINES

**Note:** For the most current package drawings, please see the Microchip Packaging Specification located at <http://www.microchip.com/packaging>

**FIGURE 12-1: 32-PIN 5MM × 5MM WQFN PACKAGE OUTLINE AND RECOMMENDED LAND PATTERN**

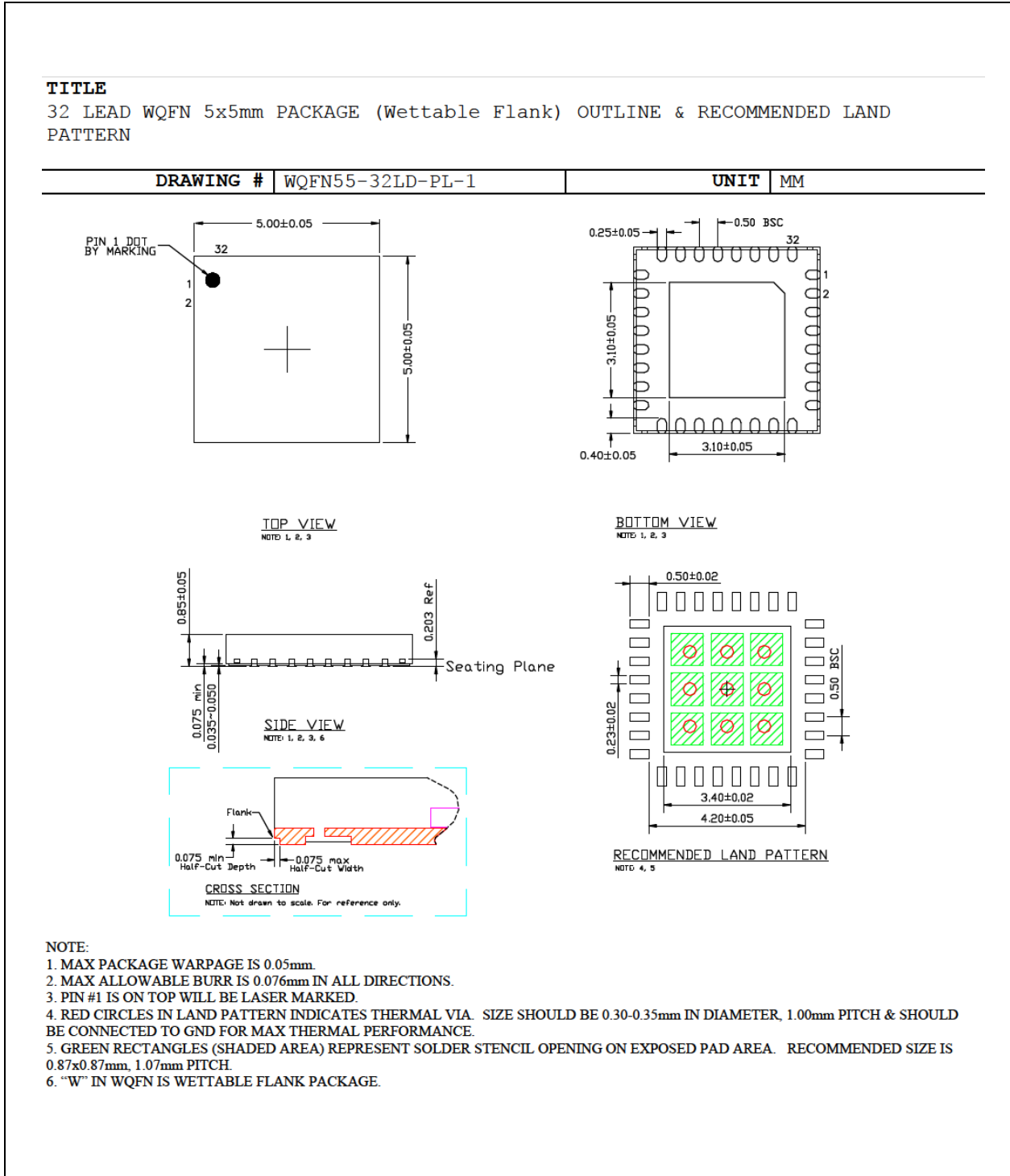

**Note:** For the most current package drawings, please see the Microchip Packaging Specification located at <http://www.microchip.com/packaging>

**FIGURE 12-2: 32-PIN 5MM × 5MM QFN PACKAGE OUTLINE AND RECOMMENDED LAND PATTERN**

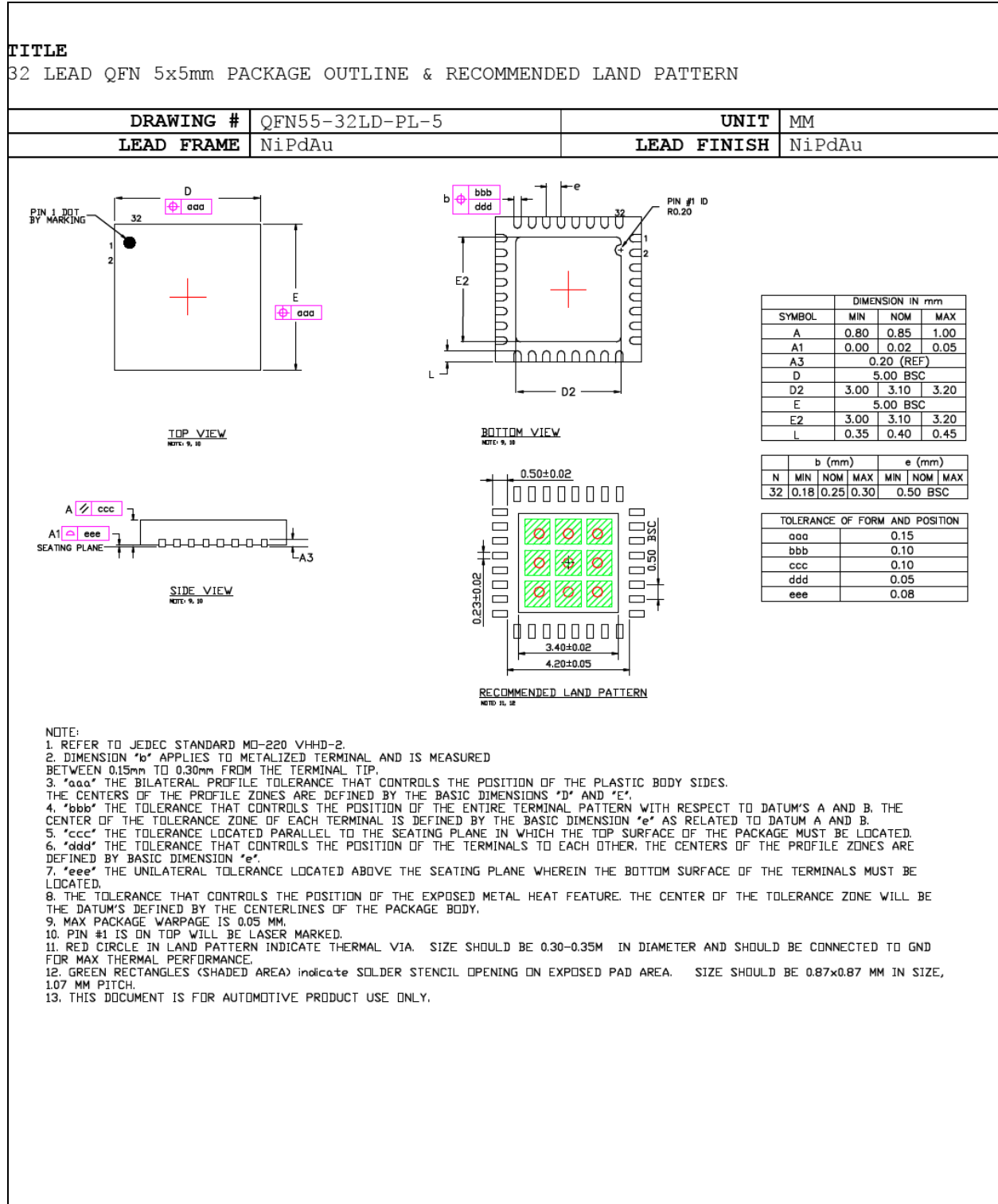

# KSZ8061RNB/RND

## APPENDIX A: DATA SHEET REVISION HISTORY

TABLE A-1: CUSTOMER REVISION HISTORY

Revision Level and Date	Section/Figure/Entry	Correction
DS00002197F (01-11-19)	Table 2-1, "Signals"	Corrected the measurement unit, from Ohm to kOhm (in symbol) of the resistor that should be connected to the REXT pin to ground.
	Table 3-5, "Typical SQI values"	Corrected a text ("SQL" to "SQI") in the column title.
	Table 4-3, "Standard Register Description"	Updated the description of RX PHY Latency Address, Register 18h - Expanded Control. Updated the description of Force Link, Register 1Fh - PHY Control 2.
	Table 9-1, "25 MHz Crystal/Reference Clock Selection Criteria"	Added a new row for Crystal Drive Level.
	Figure 1-1, "System Block Diagram"	Corrected the arrows for INTRP and SIGNAL DETECT lines.
	Figure 9-1, "KSZ8061RNB 25-MHz Crystal/Oscillator Reference Clock Connection"	Removed the 22 pF values on the capacitors.
	Figure 10-1, "KSZ8061RND 50-MHz Clock Connection"	Added frequency tolerance of $\pm 50$ ppm to the figure.
	RMII Back-to-Back Mode on page 14	Removed the "Back-to-Back mode - 100 Mbps Repeater" section title and moved the contents to "RMII Back-to-Back mode" section.
	LinkMD <sup>®</sup> Cable Diagnostics on page 19	Updated the fourth step under Step 1, and the third step under Step 2. Added a new paragraph.
	LinkMD <sup>®</sup> + Enhanced Diagnostics: Receive Signal Quality Indicator on page 20	Updated the last sentence of the first paragraph to say "environmental EM noise."
	Operating Conditions** on page 38	Added a temperature value for TA, Industrial.
	Reference Clock Connection - KSZ8061RND on page 48	Updated the third sentence of the first paragraph.
	Magnetic – Connection and Selection on page 49	Added this section.
DS00002197E (01-12-18)	All	Corrected errant part number references throughout the document that were introduced in Revision D.
	Introduction on page 4 and Pin Description and Configuration on page 5	Interchanged the order of the sections.
DS00002197D (12-20-17)	Table 4-3, "Standard Register Description," on page 26	Added a note to Register 12h - AFE Control 1 Register.
	All	Minor text changes throughout.
DS00002197C (03-03-17)	Table of Contents, Section 12.0, "Package Outlines", Appendix A: "Data Sheet Revision History"	Minor update to page headers.
	Product Identification System on page 55	Minor correction Examples section.

**TABLE A-1: CUSTOMER REVISION HISTORY (CONTINUED)**

Revision Level and Date	Section/Figure/Entry	Correction
DS00002197B (01-27-17)	All	Sales listing and cover pages updated. Minor text changes throughout.
	<a href="#">Highlights on page 1</a>	Added this section.
	<a href="#">Table 2-2, "Strap-in Options," on page 8</a>	CONFIG[2:0] 101 and 111 descriptions updated (Auto-MDI/MDI-X enabled).
	<a href="#">Product Identification System on page 55</a>	PIS ordering code temperature descriptions corrected. Removed note.
	<a href="#">Table 4-1, "Standard Registers," on page 25 and Table 4-3, "Standard Register Description," on page 26</a>	AFE Control 1 register information added.
	<a href="#">Table 6-1, "Electrical Characteristics," on page 39</a>	Removed IVDDIO_1.8 section.
DS00002197A (08-08-16)	Whole Document	Conversion of Micrel KSZ8061RNB/ KSZ8061RND/KSZ8061RNB/KSZ8061RND datasheet into Microchip DS00002197F. Minor text changes throughout.

# KSZ8061RNB/RND

---

## THE MICROCHIP WEB SITE

Microchip provides online support via our WWW site at [www.microchip.com](http://www.microchip.com). This web site is used as a means to make files and information easily available to customers. Accessible by using your favorite Internet browser, the web site contains the following information:

- **Product Support** – Data sheets and errata, application notes and sample programs, design resources, user's guides and hardware support documents, latest software releases and archived software
- **General Technical Support** – Frequently Asked Questions (FAQ), technical support requests, online discussion groups, Microchip consultant program member listing
- **Business of Microchip** – Product selector and ordering guides, latest Microchip press releases, listing of seminars and events, listings of Microchip sales offices, distributors and factory representatives

## CUSTOMER CHANGE NOTIFICATION SERVICE

Microchip's customer notification service helps keep customers current on Microchip products. Subscribers will receive e-mail notification whenever there are changes, updates, revisions or errata related to a specified product family or development tool of interest.

To register, access the Microchip web site at [www.microchip.com](http://www.microchip.com). Under "Support", click on "Customer Change Notification" and follow the registration instructions.

## CUSTOMER SUPPORT

Users of Microchip products can receive assistance through several channels:

- Distributor or Representative
- Local Sales Office
- Field Application Engineer (FAE)
- Technical Support

Customers should contact their distributor, representative or Field Application Engineer (FAE) for support. Local sales offices are also available to help customers. A listing of sales offices and locations is included in the back of this document.

**Technical support is available through the web site at: <http://microchip.com/support>**

# KSZ8061RNB/RND

## PRODUCT IDENTIFICATION SYSTEM

To order or obtain information, e.g., on pricing or delivery, refer to the factory or the listed sales office.

<u>PART NO.</u>	X	X	X	X
Device	Interface	Package	Reference Clock	Temperature
<b>Device:</b>	KSZ8061RNB/RND			
<b>Interface:</b>	R =	RMII Interface		
<b>Package:</b>	N =	32-pin QFN or WQFN		
<b>Reference Clock:</b>	B =	50 MHz RMII clock output		
	D =	50 MHz RMII clock input		
<b>Temperature Range:</b>	I =	-40°C to +85°C (Industrial)		
	V =	-40°C to +105°C (Automotive-Qualified Extended)		
	W =	-40°C to +105°C (Industrial Extended)		

**Examples:**

- a) KSZ8061RNBV  
RMII Interface, 32-pin WQFN,  
50-MHz RMII clock output,  
AEC-Q100 Automotive-Qualified Extended  
temperature
- b) KSZ8061RNBW  
RMII Interface, 32-pin QFN, 50-MHz RMII clock  
output, Industrial Extended temperature
- c) KSZ8061RNDV  
RMII Interface, 32-pin WQFN, 50-MHz RMII  
clock input, AEC-Q100 Automotive-Qualified  
Extended temperature
- d) KSZ8061RNDW  
RMII Interface, 32-pin QFN, 50-MHz RMII clock  
input, Industrial Extended temperature

# KSZ8061RNB/RND

---

NOTES:



---

**Note the following details of the code protection feature on Microchip devices:**

- Microchip products meet the specification contained in their particular Microchip Data Sheet.
- Microchip believes that its family of products is one of the most secure families of its kind on the market today, when used in the intended manner and under normal conditions.
- There are dishonest and possibly illegal methods used to breach the code protection feature. All of these methods, to our knowledge, require using the Microchip products in a manner outside the operating specifications contained in Microchip's Data Sheets. Most likely, the person doing so is engaged in theft of intellectual property.
- Microchip is willing to work with the customer who is concerned about the integrity of their code.
- Neither Microchip nor any other semiconductor manufacturer can guarantee the security of their code. Code protection does not mean that we are guaranteeing the product as “unbreakable.”

Code protection is constantly evolving. We at Microchip are committed to continuously improving the code protection features of our products. Attempts to break Microchip's code protection feature may be a violation of the Digital Millennium Copyright Act. If such acts allow unauthorized access to your software or other copyrighted work, you may have a right to sue for relief under that Act.

---

Information contained in this publication regarding device applications and the like is provided only for your convenience and may be superseded by updates. It is your responsibility to ensure that your application meets with your specifications. MICROCHIP MAKES NO REPRESENTATIONS OR WARRANTIES OF ANY KIND WHETHER EXPRESS OR IMPLIED, WRITTEN OR ORAL, STATUTORY OR OTHERWISE, RELATED TO THE INFORMATION, INCLUDING BUT NOT LIMITED TO ITS CONDITION, QUALITY, PERFORMANCE, MERCHANTABILITY OR FITNESS FOR PURPOSE. Microchip disclaims all liability arising from this information and its use. Use of Microchip devices in life support and/or safety applications is entirely at the buyer's risk, and the buyer agrees to defend, indemnify and hold harmless Microchip from any and all damages, claims, suits, or expenses resulting from such use. No licenses are conveyed, implicitly or otherwise, under any Microchip intellectual property rights unless otherwise stated.

**Trademarks**

The Microchip name and logo, the Microchip logo, AnyRate, AVR, AVR logo, AVR Freaks, BitCloud, chipKIT, chipKIT logo, CryptoMemory, CryptoRF, dsPIC, FlashFlex, flexPWR, Heldo, JukeBlox, KeeLoq, Klear, LANCheck, LinkMD, maXStylus, maXTouch, MedialB, megaAVR, MOST, MOST logo, MPLAB, OptoLyzer, PIC, picoPower, PICSTART, PIC32 logo, Prochip Designer, QTouch, SAM-BA, SpyNIC, SST, SST Logo, SuperFlash, tinyAVR, UNI/O, and XMEGA are registered trademarks of Microchip Technology Incorporated in the U.S.A. and other countries.

ClockWorks, The Embedded Control Solutions Company, EtherSynch, Hyper Speed Control, HyperLight Load, IntellIMOS, mTouch, Precision Edge, and Quiet-Wire are registered trademarks of Microchip Technology Incorporated in the U.S.A.

Adjacent Key Suppression, AKS, Analog-for-the-Digital Age, Any Capacitor, AnyIn, AnyOut, BodyCom, CodeGuard, CryptoAuthentication, CryptoAutomotive, CryptoCompanion, CryptoController, dsPICDEM, dsPICDEM.net, Dynamic Average Matching, DAM, ECAN, EtherGREEN, In-Circuit Serial Programming, ICSP, INICnet, Inter-Chip Connectivity, JitterBlocker, KlearNet, KlearNet logo, memBrain, Mindi, MiWi, motorBench, MPASM, MPF, MPLAB Certified logo, MPLIB, MPLINK, MultiTRAK, NetDetach, Omniscient Code Generation, PICDEM, PICDEM.net, PICkit, PICtail, PowerSmart, PureSilicon, QMatrix, REAL ICE, Ripple Blocker, SAM-ICE, Serial Quad I/O, SMART-I.S., SQI, SuperSwitcher, SuperSwitcher II, Total Endurance, TSHARC, USBCheck, VariSense, ViewSpan, WiperLock, Wireless DNA, and ZENA are trademarks of Microchip Technology Incorporated in the U.S.A. and other countries.

SQTP is a service mark of Microchip Technology Incorporated in the U.S.A.

Silicon Storage Technology is a registered trademark of Microchip Technology Inc. in other countries.

GestIC is a registered trademark of Microchip Technology Germany II GmbH & Co. KG, a subsidiary of Microchip Technology Inc., in other countries.

All other trademarks mentioned herein are property of their respective companies.

© 2016-2019, Microchip Technology Incorporated, All Rights Reserved.

ISBN: 978-1-5224-4043-7

**QUALITY MANAGEMENT SYSTEM**  
**CERTIFIED BY DNV**  
**== ISO/TS 16949 ==**

*Microchip received ISO/TS-16949:2009 certification for its worldwide headquarters, design and wafer fabrication facilities in Chandler and Tempe, Arizona; Gresham, Oregon and design centers in California and India. The Company's quality system processes and procedures are for its PIC® MCUs and dsPIC® DSCs, KEELoq® code hopping devices, Serial EEPROMs, microperipherals, nonvolatile memory and analog products. In addition, Microchip's quality system for the design and manufacture of development systems is ISO 9001:2000 certified.*



# MICROCHIP

## Worldwide Sales and Service

### AMERICAS

**Corporate Office**  
2355 West Chandler Blvd.  
Chandler, AZ 85224-6199  
Tel: 480-792-7200  
Fax: 480-792-7277  
Technical Support:  
<http://www.microchip.com/support>  
Web Address:  
[www.microchip.com](http://www.microchip.com)

#### Atlanta

Duluth, GA  
Tel: 678-957-9614  
Fax: 678-957-1455

#### Austin, TX

Tel: 512-257-3370

#### Boston

Westborough, MA  
Tel: 774-760-0087  
Fax: 774-760-0088

#### Chicago

Itasca, IL  
Tel: 630-285-0071  
Fax: 630-285-0075

#### Dallas

Addison, TX  
Tel: 972-818-7423  
Fax: 972-818-2924

#### Detroit

Novi, MI  
Tel: 248-848-4000

#### Houston, TX

Tel: 281-894-5983

#### Indianapolis

Noblesville, IN  
Tel: 317-773-8323  
Fax: 317-773-5453  
Tel: 317-536-2380

#### Los Angeles

Mission Viejo, CA  
Tel: 949-462-9523  
Fax: 949-462-9608  
Tel: 951-273-7800

#### Raleigh, NC

Tel: 919-844-7510

#### New York, NY

Tel: 631-435-6000

#### San Jose, CA

Tel: 408-735-9110  
Tel: 408-436-4270

#### Canada - Toronto

Tel: 905-695-1980  
Fax: 905-695-2078

### ASIA/PACIFIC

**Australia - Sydney**  
Tel: 61-2-9868-6733

**China - Beijing**  
Tel: 86-10-8569-7000

**China - Chengdu**  
Tel: 86-28-8665-5511

**China - Chongqing**  
Tel: 86-23-8980-9588

**China - Dongguan**  
Tel: 86-769-8702-9880

**China - Guangzhou**  
Tel: 86-20-8755-8029

**China - Hangzhou**  
Tel: 86-571-8792-8115

**China - Hong Kong SAR**  
Tel: 852-2943-5100

**China - Nanjing**  
Tel: 86-25-8473-2460

**China - Qingdao**  
Tel: 86-532-8502-7355

**China - Shanghai**  
Tel: 86-21-3326-8000

**China - Shenyang**  
Tel: 86-24-2334-2829

**China - Shenzhen**  
Tel: 86-755-8864-2200

**China - Suzhou**  
Tel: 86-186-6233-1526

**China - Wuhan**  
Tel: 86-27-5980-5300

**China - Xian**  
Tel: 86-29-8833-7252

**China - Xiamen**  
Tel: 86-592-2388138

**China - Zhuhai**  
Tel: 86-756-3210040

### ASIA/PACIFIC

**India - Bangalore**  
Tel: 91-80-3090-4444

**India - New Delhi**  
Tel: 91-11-4160-8631

**India - Pune**  
Tel: 91-20-4121-0141

**Japan - Osaka**  
Tel: 81-6-6152-7160

**Japan - Tokyo**  
Tel: 81-3-6880-3770

**Korea - Daegu**  
Tel: 82-53-744-4301

**Korea - Seoul**  
Tel: 82-2-554-7200

**Malaysia - Kuala Lumpur**  
Tel: 60-3-7651-7906

**Malaysia - Penang**  
Tel: 60-4-227-8870

**Philippines - Manila**  
Tel: 63-2-634-9065

**Singapore**  
Tel: 65-6334-8870

**Taiwan - Hsin Chu**  
Tel: 886-3-577-8366

**Taiwan - Kaohsiung**  
Tel: 886-7-213-7830

**Taiwan - Taipei**  
Tel: 886-2-2508-8600

**Thailand - Bangkok**  
Tel: 66-2-694-1351

**Vietnam - Ho Chi Minh**  
Tel: 84-28-5448-2100

### EUROPE

**Austria - Wels**  
Tel: 43-7242-2244-39  
Fax: 43-7242-2244-393

**Denmark - Copenhagen**  
Tel: 45-4450-2828  
Fax: 45-4485-2829

**Finland - Espoo**  
Tel: 358-9-4520-820

**France - Paris**  
Tel: 33-1-69-53-63-20  
Fax: 33-1-69-30-90-79

**Germany - Garching**  
Tel: 49-8931-9700

**Germany - Haan**  
Tel: 49-2129-3766400

**Germany - Heilbronn**  
Tel: 49-7131-67-3636

**Germany - Karlsruhe**  
Tel: 49-721-625370

**Germany - Munich**  
Tel: 49-89-627-144-0  
Fax: 49-89-627-144-44

**Germany - Rosenheim**  
Tel: 49-8031-354-560

**Israel - Ra'anana**  
Tel: 972-9-744-7705

**Italy - Milan**  
Tel: 39-0331-742611  
Fax: 39-0331-466781

**Italy - Padova**  
Tel: 39-049-7625286

**Netherlands - Drunen**  
Tel: 31-416-690399  
Fax: 31-416-690340

**Norway - Trondheim**  
Tel: 47-7288-4388

**Poland - Warsaw**  
Tel: 48-22-3325737

**Romania - Bucharest**  
Tel: 40-21-407-87-50

**Spain - Madrid**  
Tel: 34-91-708-08-90  
Fax: 34-91-708-08-91

**Sweden - Gothenberg**  
Tel: 46-31-704-60-40

**Sweden - Stockholm**  
Tel: 46-8-5090-4654

**UK - Wokingham**  
Tel: 44-118-921-5800  
Fax: 44-118-921-5820