

ASSEMBLY INSTRUCTIONS:

- A) Lay S2000 data terminal on flat surface. Remove rear door and hardware from terminal. Undo 1/4-20 screws and washers. Lay door aside until extension ring (item 1) is mounted.
- B) Place extension ring onto rear of terminal. Align mounting holes. Locate the mounting hole in rear flange of extension ring on either side, mark and drill extra holes into terminal using a .281(7.1mm) drill bit. Remove extension ring before drilling into terminal.
- C) Apply silicon to rear surface of terminal. Run a smooth and continuous bead around the perimeter of terminal and mounting holes. Note: Silicon is not included with extension ring.
- D) Place extension ring (item 1) onto terminal and line up with mounting holes and perimeter of enclosure.
- E) Fasten using 1/4-20 screws (item 2) and KEP nuts (item 3) supplied.
- F) Assemble door, hinges and stops onto surface of extension ring

Note: Door and related hardware must be removed from rear of data terminal and added to extension ring after ring and terminal are assembled. See STEP F

Use silicone sealant (clear with U/V block) Not supplied. Apply along outside perimeter of data terminal before assembly. See STEP C

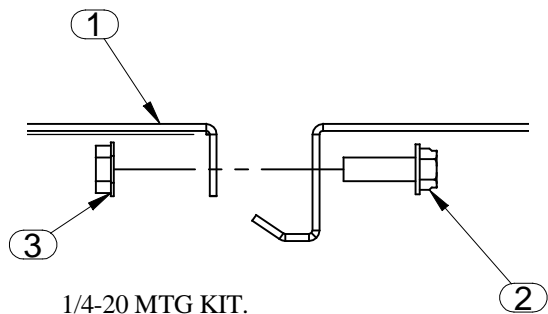

DETAIL A

PARTS LIST		
ITEM No.	DESCRIPTION	QTY
1	EXTENSION RING	1
2	1/4-20 SCREW	8
3	1/4-20 KEP NUT	8

TOOL BOX

