

FEATURES

- High Accuracy, Supports 50 Hz/60 Hz IEC 687/1036**
- Less than 0.1% Error over a Dynamic Range of 500 to 1**
- Supplies Average Real Power on the Frequency Outputs F1 and F2**
- High-Frequency Output CF Is Intended for Calibration and Supplies Instantaneous Real Power**
- Continuous Monitoring of the Phase and Neutral Current Allows Fault Detection in Two-Wire Distribution Systems**
- AD7751 Uses the Larger of the Two Currents (Phase or Neutral) to Bill—Even During a Fault Condition**
- Two Logic Outputs (FAULT and REVP) Can be Used to Indicate a Potential Miswiring or Fault Condition**
- Direct Drive for Electromechanical Counters and Two-Phase Stepper Motors (F1 and F2)**
- A PGA in the Current Channel Allows the Use of Small Values of Shunt and Burden Resistance**
- Proprietary ADCs and DSP Provide High Accuracy Over Large Variations in Environmental Conditions and Time**
- On-Chip Power Supply Monitoring**
- On-Chip Creep Protection (No Load Threshold)**
- On-Chip Reference 2.5 V \pm 8% (30 ppm/ $^{\circ}$ C Typical) with External Overdrive Capability**
- Single 5 V Supply, Low Power (15 mW Typical)**
- Low-Cost CMOS Process**

The only analog circuitry used in the AD7751 is in the ADCs and reference circuit. All other signal processing (e.g., multiplication and filtering) is carried out in the digital domain. This approach provides superior stability and accuracy over extremes in environmental conditions and over time.

The AD7751 incorporates a novel fault detection scheme that warns of fault conditions and allows the AD7751 to continue accurate billing during a fault event. The AD7751 does this by continuously monitoring both the phase and neutral (return) currents. A fault is indicated when these currents differ by more than 12.5%. Billing is continued using the larger of the two currents.

The AD7751 supplies average real power information on the low-frequency outputs F1 and F2. These logic outputs may be used to directly drive an electromechanical counter or interface to an MCU. The CF logic output gives instantaneous real power information. This output is intended to be used for calibration purposes.

The AD7751 includes a power supply monitoring circuit on the AV_{DD} supply pin. The AD7751 will remain in a reset condition until the supply voltage on AV_{DD} reaches 4 V. If the supply falls below 4 V, the AD7751 will also be reset and no pulses will be issued on F1, F2, and CF.

Internal phase matching circuitry ensures that the voltage and current channels are matched whether the HPF in Channel 1 is on or off. The AD7751 also has anticreep protection.

The AD7751 is available in 24-lead DIP and SSOP packages.

GENERAL DESCRIPTION

The AD7751 is a high-accuracy fault-tolerant electrical energy measurement IC that is intended for use with 2-wire distribution systems. The part specifications surpass the accuracy requirements as quoted in the IEC1036 standard.

FUNCTIONAL BLOCK DIAGRAM

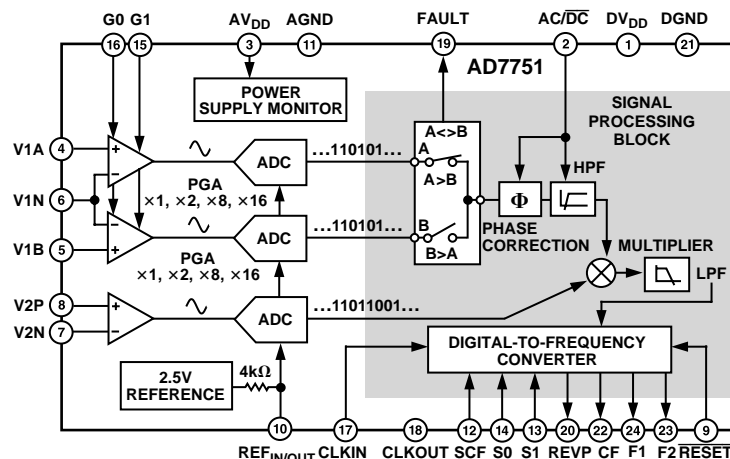

*US Patent 5,745,323; 5,760,617; 5,862,069; 5,872,469.

REV. B

Information furnished by Analog Devices is believed to be accurate and reliable. However, no responsibility is assumed by Analog Devices for its use, nor for any infringements of patents or other rights of third parties that may result from its use. No license is granted by implication or otherwise under any patent or patent rights of Analog Devices.

AD7751—SPECIFICATIONS^{1, 2} ($AV_{DD} = DV_{DD} = 5 V \pm 5\%$, $AGND = DGND = 0 V$, On-Chip Reference, $CLKIN = 3.58 MHz$, T_{MIN} to $T_{MAX} = -40^{\circ}C$ to $+85^{\circ}C$)

Parameter	A Version	B Version	Unit	Test Conditions/Comments
ACCURACY³				
Measurement Error ¹ on Channels 1 and 2				One Channel with Full-Scale Signal ($\pm 660 mV$)
Gain = 1	0.1	0.1	% Reading typ	Over a Dynamic Range 500 to 1
Gain = 2	0.1	0.1	% Reading typ	Over a Dynamic Range 500 to 1
Gain = 8	0.1	0.1	% Reading typ	Over a Dynamic Range 500 to 1
Gain = 16	0.1	0.1	% Reading typ	Over a Dynamic Range 500 to 1
Phase Error ¹ Between Channels				Line Frequency = 45 Hz to 55 Hz
V1 Phase Lead 37°				
(PF = 0.8 Capacitive)	± 0.1	± 0.1	Degrees(°) max	$AC/\overline{DC} = 0$ and $AC/\overline{DC} = 1$
V1 Phase Lag 60°				
(PF = 0.5 Inductive)	± 0.1	± 0.1	Degrees(°) max	$AC/\overline{DC} = 0$ and $AC/\overline{DC} = 1$
AC Power Supply Rejection ¹				$AC/\overline{DC} = 1$, $S0 = S1 = 1$, $G0 = G1 = 0$
Output Frequency Variation (CF)	0.2	0.2	% Reading typ	$V1 = 100 mV rms$, $V2 = 100 mV rms @ 50 Hz$
DC Power Supply Rejection ¹				Ripple on AV_{DD} of $200 mV rms @ 100 Hz$
Output Frequency Variation (CF)	± 0.3	± 0.3	% Reading typ	$AC/\overline{DC} = 1$, $S0 = S1 = 1$, $G0 = G1 = 0$
				$V1 = 100 mV rms$, $V2 = 100 mV rms$, $AV_{DD} = DV_{DD} = 5 V \pm 250 mV$
FAULT DETECTION^{1, 4}				
Fault Detection Threshold				See Fault Detection Section
Inactive i/p <> Active i/p	12.5	12.5	% typ	(V1A or V1B Active)
Input Swap Threshold				
Inactive i/p > Active i/p	14	14	% of Active typ	(V1A or V1B Active)
Accuracy Fault Mode Operation				
V1A Active, V1B = AGND	0.1	0.1	% Reading typ	Over a Dynamic Range 500 to 1
V1B Active, V1A = AGND	0.1	0.1	% Reading typ	Over a Dynamic Range 500 to 1
Fault Detection Delay	3	3	Second typ	
Swap Delay	3	3	Second typ	
ANALOG INPUTS				
Maximum Signal Levels	± 1	± 1	V max	See Analog Inputs Section
Input Impedance (DC)	390	390	k Ω min	V1A, V1B, V1N, V2N and V2P to AGND
Bandwidth	14	14	kHz typ	$CLKIN = 3.58 MHz$
ADC Offset Error ¹	± 25	± 25	mV max	$CLKIN/256$, $CLKIN = 3.58 MHz$
Gain Error ¹	± 10	± 10	% Ideal typ	See Terminology and Performance Graphs
				External 2.5 V Reference, Gain = 1,
Gain Error Match ¹	± 0.4	± 0.4	% Ideal typ	$V1 = V2 = 660 mV dc$
				External 2.5 V Reference
REFERENCE INPUT				
REF _{IN/OUT} Input Voltage Range	2.7	2.7	V max	2.5 V + 8%
	2.3	2.3	V min	2.5 V - 8%
Input Impedance	3.2	3.2	k Ω min	
Input Capacitance	10	10	pF max	
ON-CHIP REFERENCE				
Reference Error	± 200	± 200	mV max	Nominal 2.5 V
Temperature Coefficient	± 30	± 30	ppm/°C typ	
		± 60	ppm/°C max	
CLKIN				
Input Clock Frequency	4	4	MHz max	Note All Specifications for CLKIN of 3.58 MHz
	1	1	MHz min	
LOGIC INPUTS⁵				
SCF, S0, S1, AC/\overline{DC} , \overline{RESET} , G0 and G1				
Input High Voltage, V_{INH}	2.4	2.4	V min	$DV_{DD} = 5 V \pm 5\%$
Input Low Voltage, V_{INL}	0.8	0.8	V max	$DV_{DD} = 5 V \pm 5\%$
Input Current, I_{IN}	± 3	± 3	μA max	Typically 10 nA, $V_{IN} = 0 V$ to DV_{DD}
Input Capacitance, C_{IN}	10	10	pF max	

Parameter	A Version	B Version	Unit	Test Conditions/Comments
LOGIC OUTPUTS⁴				
F1 and F2 Output High Voltage, V_{OH}	4.5	4.5	V min	$I_{SOURCE} = 10\text{ mA}$ $DV_{DD} = 5\text{ V}$
Output Low Voltage, V_{OL}	0.5	0.5	V max	$I_{SINK} = 10\text{ mA}$ $DV_{DD} = 5\text{ V}$
CF, FAULT, and REVP Output High Voltage, V_{OH}	4	4	V min	$I_{SOURCE} = 5\text{ mA}$ $DV_{DD} = 5\text{ V}$
Output Low Voltage, V_{OL}	0.5	0.5	V max	$I_{SINK} = 5\text{ mA}$ $DV_{DD} = 5\text{ V}$
POWER SUPPLY				
AV_{DD}	4.75	4.75	V min	For Specified Performance
	5.25	5.25	V max	5 V – 5%
DV_{DD}	4.75	4.75	V min	5 V – 5%
	5.25	5.25	V max	5 V + 5%
AI_{DD}	3	3	mA max	Typically 2 mA
DI_{DD}	2.5	2.5	mA max	Typically 1.5 mA

NOTES

¹See Terminology section for explanation of specifications.²See plots in Typical Performance Characteristics graphs.³See Fault Detection section of data sheet for explanation of fault detection functionality.⁴Sample tested during initial release and after any redesign or process change that may affect this parameter.

Specifications subject to change without notice.

TIMING CHARACTERISTICS^{1, 2} ($AV_{DD} = DV_{DD} = 5\text{ V} \pm 5\%$, $AGND = DGND = 0\text{ V}$, On-Chip Reference, $CLKIN = 3.58\text{ MHz}$, T_{MIN} to $T_{MAX} = -40^{\circ}\text{C}$ to $+85^{\circ}\text{C}$)

Parameter	A, B Versions	Unit	Test Conditions/Comments
t_1 ³	275	ms	F1 and F2 Pulsewidth (Logic Low)
t_2	See Table III	sec	Output Pulse Period. See Transfer Function Section
t_3	$1/2 t_2$	sec	Time Between F1 Falling Edge and F2 Falling Edge
t_4 ³	90	ms	CF Pulsewidth (Logic High)
t_5	See Table IV	sec	CF Pulse Period. See Transfer Function Section
t_6	$CLKIN/4$	sec	Minimum Time Between F1 and F2 Pulse

NOTES

¹Sample tested during initial release and after any redesign or process change that may affect this parameter.²See Figure 1.³The pulsewidths of F1, F2 and CF are not fixed for higher output frequencies. See Frequency Outputs section.

Specifications subject to change without notice.

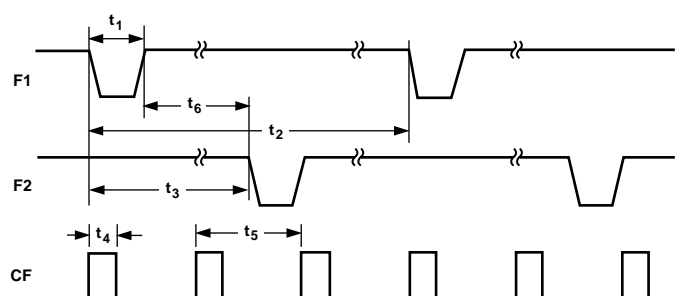

Figure 1. Timing Diagram for Frequency Outputs

ORDERING GUIDE

Model	Package Description	Package Option
AD7751AAN	Plastic DIP	N-24
AD7751AARS	Shrink Small Outline Package	RS-24
AD7751ABRS	Shrink Small Outline Package	RS-24
EVAL-AD7751EB	AD7751 Evaluation Board	
AD7751AAN-REF	AD7751 Reference Design PCB (See AN-563)	

AD7751

ABSOLUTE MAXIMUM RATINGS*

(T_A = 25°C unless otherwise noted)

AV _{DD} to AGND	−0.3 V to +7 V
DV _{DD} to DGND	−0.3 V to +7 V
DV _{DD} to AV _{DD}	−0.3 V to +0.3 V
Analog Input Voltage to AGND	
V1A, V1B, V1N, V2P, and V2N	−6 V to +6 V
Reference Input Voltage to AGND	−0.3 V to AV _{DD} + 0.3 V
Digital Input Voltage to DGND	−0.3 V to DV _{DD} + 0.3 V
Digital Output Voltage to DGND	−0.3 V to DV _{DD} + 0.3 V
Operating Temperature Range	
Industrial (A, B Versions)	−40°C to +85°C
Storage Temperature Range	−65°C to +150°C
Junction Temperature	150°C

24-Lead Plastic DIP, Power Dissipation	450 mW
θ _{JA} Thermal Impedance	105°C/W
Lead Temperature, (Soldering 10 sec)	260°C
24-Lead SSOP, Power Dissipation	450 mW
θ _{JA} Thermal Impedance	112°C/W
Lead Temperature, Soldering	
Vapor Phase (60 sec)	215°C
Infrared (15 sec)	220°C

*Stresses above those listed under Absolute Maximum Ratings may cause permanent damage to the device. This is a stress rating only; functional operation of the device at these or any other conditions above those listed in the operational sections of this specification is not implied. Exposure to absolute maximum rating conditions for extended periods may affect device reliability.

CAUTION

ESD (electrostatic discharge) sensitive device. Electrostatic charges as high as 4000 V readily accumulate on the human body and test equipment and can discharge without detection. Although the AD7751 features proprietary ESD protection circuitry, permanent damage may occur on devices subjected to high-energy electrostatic discharges. Therefore, proper ESD precautions are recommended to avoid performance degradation or loss of functionality.



TERMINOLOGY

MEASUREMENT ERROR

The error associated with the energy measurement made by the AD7751 is defined by the following formula:

Percentage Error =

$$\frac{\text{Energy Registered by the AD7751} - \text{True Energy}}{\text{True Energy}} \times 100\%$$

PHASE ERROR BETWEEN CHANNELS

The HPF (High-Pass Filter) in Channel 1 has a phase lead response. To offset this phase response and equalize the phase response between channels a phase correction network is also placed in Channel 1. The phase correction network matches the phase to within ±0.1° over a range of 45 Hz to 65 Hz and ±0.2° over a range 40 Hz to 1 kHz (see Figures 10 and 11).

ADC OFFSET ERROR

This refers to the dc offset associated with the analog inputs to the ADCs. It means that with the analog inputs connected to AGND the ADCs still see an analog input signal of 1 mV to 10 mV. However, when the HPF is switched on the offset is removed from the current channel and the power calculation is not affected by this offset.

POWER SUPPLY REJECTION

This quantifies the AD7751 measurement error as a percentage of reading when the power supplies are varied.

For the ac PSR measurement a reading at nominal supplies (5 V) is taken. A 200 mV rms/100 Hz signal is then introduced onto the supplies and a second reading obtained under the same input signal levels. Any error introduced is expressed as a percentage of reading—see Measurement Error definition.

For the dc PSR measurement a reading at nominal supplies (5 V) is taken. The supplies are then varied ±5% and a second reading is obtained with the same input signal levels. Any error introduced is again expressed as a percentage of reading.

GAIN ERROR

The gain error of the AD7751 is defined as the difference between the measured output frequency (minus the offset) and the ideal output frequency. It is measured with a gain of 1 in Channel V1A. The difference is expressed as a percentage of the ideal frequency. The ideal frequency is obtained from the transfer function—see Transfer Function section.

GAIN ERROR MATCH

The gain error match is defined as the gain error (minus the offset) obtained when switching between a gain of 1 and a gain of 2, 8, or 16. It is expressed as a percentage of the output frequency obtained under a gain of 1. This gives the gain error observed when the gain selection is changed from 1 to 2, 8, or 16.

PIN FUNCTION DESCRIPTIONS

Pin No.	Mnemonic	Description
1	DV _{DD}	Digital Power Supply. This pin provides the supply voltage for the digital circuitry in the AD7751. The supply voltage should be maintained at $5\text{ V} \pm 5\%$ for specified operation. This pin should be decoupled with a $10\text{ }\mu\text{F}$ capacitor in parallel with a ceramic 100 nF capacitor.
2	AC/ $\overline{\text{DC}}$	High-Pass Filter Select. This logic input is used to enable the HPF in Channel 1 (the current channel). A Logic 1 on this pin enables the HPF. The associated phase response of this filter has been internally compensated over a frequency range of 45 Hz to 1 kHz . The HPF filter should be enabled in energy metering applications.
3	AV _{DD}	Analog Power Supply. This pin provides the supply voltage for the analog circuitry in the AD7751. The supply should be maintained at $5\text{ V} \pm 5\%$ for specified operation. Every effort should be made to minimize power supply ripple and noise at this pin by the use of proper decoupling. This pin should be decoupled to AGND with a $10\text{ }\mu\text{F}$ capacitor in parallel with a ceramic 100 nF capacitor.
4, 5	V1A, V1B	Analog Inputs for Channel 1 (Current Channel). These inputs are fully differential voltage inputs with a maximum signal level of $\pm 660\text{ mV}$ with respect to Pin V1N for specified operation. The maximum signal level at these pins is $\pm 1\text{ V}$ with respect to AGND. Both inputs have internal ESD protection circuitry and an overvoltage of $\pm 6\text{ V}$ can also be sustained on these inputs without risk of permanent damage.
6	V1N	Negative Input Pin for Differential Voltage Inputs V1A and V1B. The maximum signal level at this pin is $\pm 1\text{ V}$ with respect to AGND. The input has internal ESD protection circuitry and in addition, an overvoltage of $\pm 6\text{ V}$ can be sustained without risk of permanent damage. This input should be directly connected to the burden resistor and held at a fixed potential, i.e., AGND. See Analog Input section.
7, 8	V2N, V2P	Negative and Positive Inputs for Channel 2 (Voltage Channel). These inputs provide a fully differential input pair. The maximum differential input voltage is $\pm 660\text{ mV}$ for specified operation. The maximum signal level at these pins is $\pm 1\text{ V}$ with respect to AGND. Both inputs have internal ESD protection circuitry and an overvoltage of $\pm 6\text{ V}$ can also be sustained on these inputs without risk of permanent damage.
9	$\overline{\text{RESET}}$	Reset Pin for the AD7751. A logic low on this pin will hold the ADCs and digital circuitry in a reset condition. Bringing this pin logic low will clear the AD7751 internal registers.
10	REF _{IN/OUT}	Provides Access to the On-Chip Voltage Reference. The on-chip reference has a nominal value of $2.5\text{ V} \pm 8\%$ and a typical temperature coefficient of $30\text{ ppm}/^\circ\text{C}$. An external reference source may also be connected at this pin. In either case, this pin should be decoupled to AGND with a $1\text{ }\mu\text{F}$ ceramic capacitor and 100 nF ceramic capacitor.
11	AGND	Provides the Ground Reference for the Analog Circuitry in the AD7751, i.e., ADCs and Reference. This pin should be tied to the analog ground plane of the PCB. The analog ground plane is the ground reference for all analog circuitry, e.g., antialiasing filters, current and voltage transducers, etc. For good noise suppression the analog ground plane should only be connected to the digital ground plane at one point. A star ground configuration will help to keep noisy digital return currents away from the analog circuits.
12	SCF	Select Calibration Frequency. This logic input is used to select the frequency on the calibration output CF. Table IV shows how the calibration frequencies are selected.
13, 14	S1, S0	These logic inputs are used to select one of four possible frequencies for the digital-to-frequency conversion. This offers the designer greater flexibility when designing the energy meter. See Selecting a Frequency for an Energy Meter Application section.
15, 16	G1, G0	These logic inputs are used to select one of four possible gains for the analog inputs V1A and V1B. The possible gains are 1, 2, 8, and 16. See Analog Input section.
17	CLKIN	An external clock can be provided at this logic input. Alternatively, a parallel resonant AT crystal can be connected across CLKIN and CLKOUT to provide a clock source for the AD7751. The clock frequency for specified operation is 3.579545 MHz . Crystal load capacitors of between 22 pF and 33 pF (ceramic) should be used with the gate oscillator circuit.
18	CLKOUT	A crystal can be connected across this pin and CLKIN as described above to provide a clock source for the AD7751. The CLKOUT pin can drive one CMOS load when an external clock is supplied at CLKIN or by gate oscillator circuit.
19	FAULT	This logic output will go active high when a fault condition occurs. A fault is defined as a condition under which the signals on V1A and V1B differ by more than 12.5% . The logic output will be reset to zero when a fault condition is no longer detected. See Fault Detection section.

AD7751

Pin No.	Mnemonic	Description
20	REVP	This logic output will go logic high when negative power is detected, i.e., when the phase angle between the voltage and current signals is greater than 90° . This output is not latched and will be reset when positive power is once again detected. The output will go high or low at the same time as a pulse is issued on CF.
21	DGND	This provides the ground reference for the digital circuitry in the AD7751, i.e., multiplier, filters and digital-to-frequency converter. This pin should be tied to the analog ground plane of the PCB. The digital ground plane is the ground reference for all digital circuitry, e.g., counters (mechanical and digital), MCUs and indicator LEDs. For good noise suppression the analog ground plane should only be connected to the digital ground plane at one point, e.g., a star ground.
22	CF	Calibration Frequency Logic Output. The CF logic output gives <i>instantaneous real power</i> information. This output is intended to be used for calibration purposes. Also see SCF pin description.
23, 24	F2, F1	Low Frequency Logic Outputs. F1 and F2 supply <i>average real power</i> information. The logic outputs can be used to directly drive electromechanical counters and two-phase stepper motors. See Transfer Function section.

PIN CONFIGURATION DIP and SSOP Packages

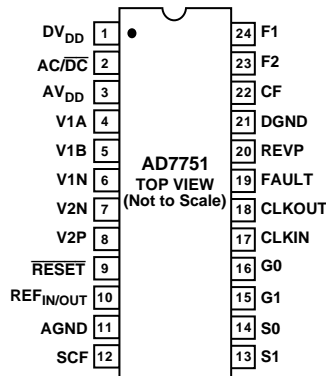

Typical Performance Characteristics—AD7751

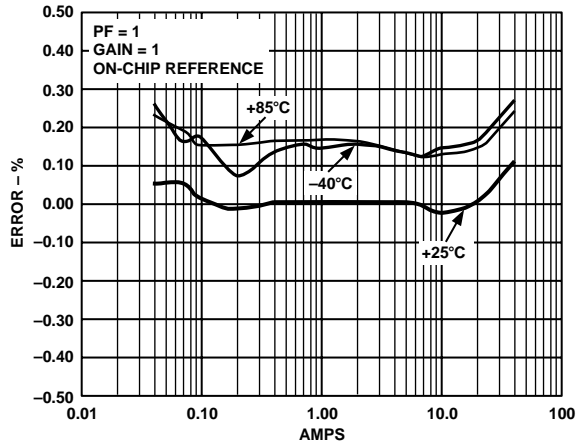

TPC 1. Error as a % of Reading (Gain = 1)

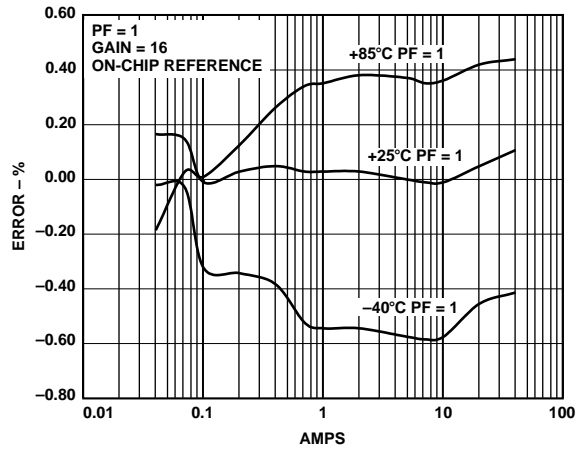

TPC 4. Error as a % of Reading (Gain = 16)

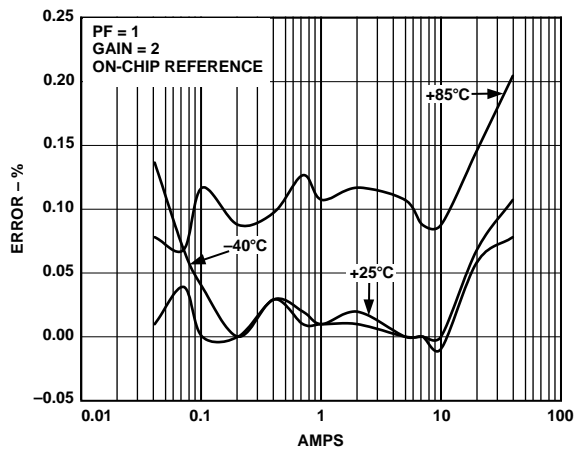

TPC 2. Error as a % of Reading (Gain = 2)

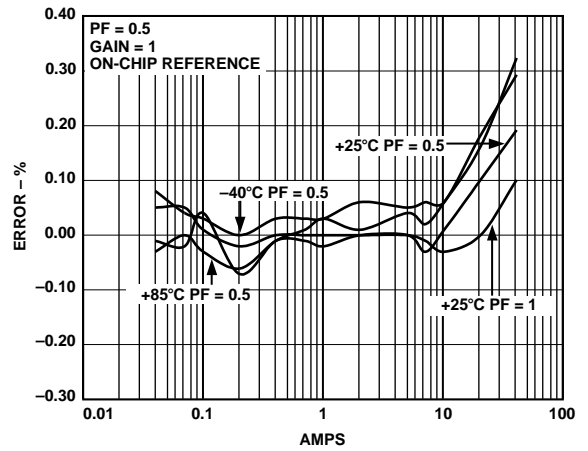

TPC 5. Error as a % of Reading (PF = 0.5, Gain = 1)

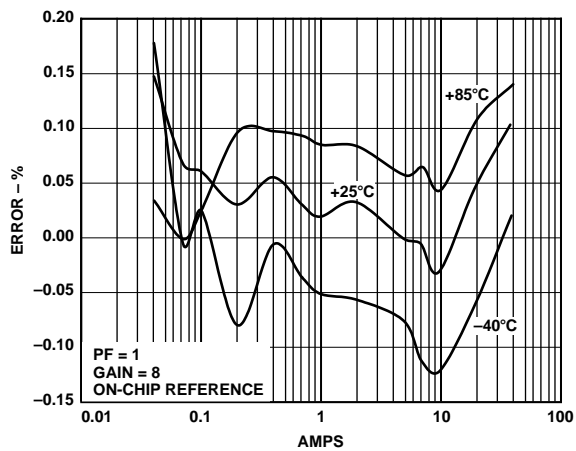

TPC 3. Error as a % of Reading (Gain = 8)

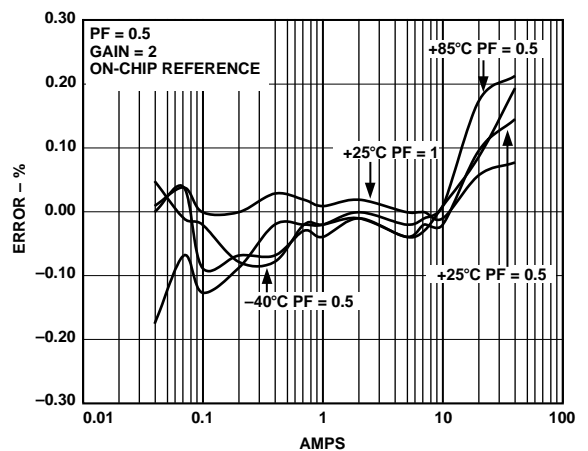

TPC 6. Error as a % of Reading (PF = 0.5, Gain = 2)

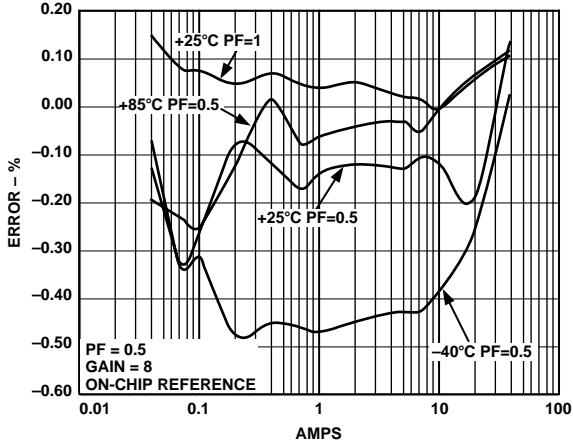

TPC 7. Error as a % of Reading (PF = 0.5, Gain = 8)

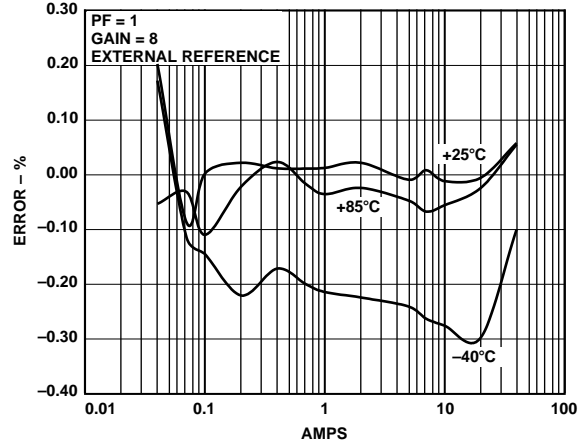

TPC 10. Error as a % of Reading Over Temperature With an External Reference (Gain = 8)

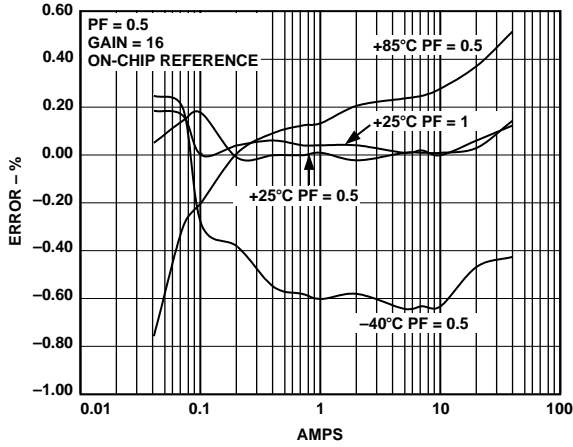

TPC 8. Error as a % of Reading (PF = 0.5, Gain = 16)

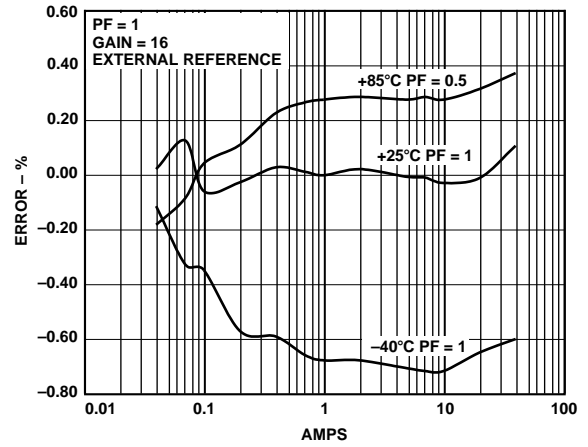

TPC 11. Error as a % of Reading Over Temperature With an External Reference (Gain = 16)

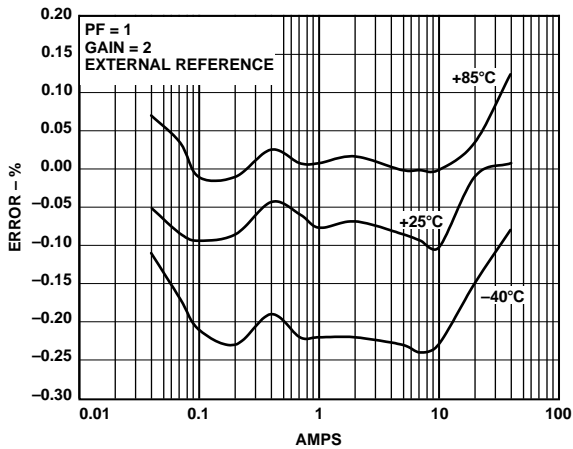

TPC 9. Error as a % of Reading Over Temperature With an External Reference (Gain = 2)

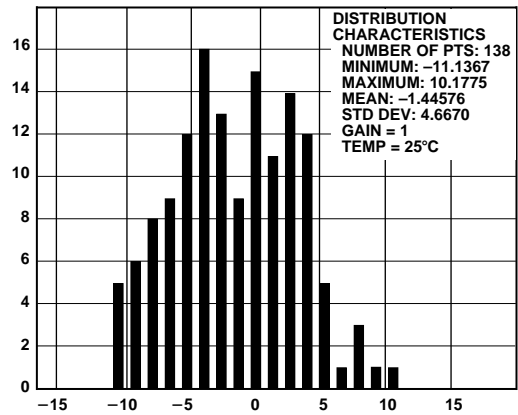

TPC 12. Channel 1 Offset Distribution (Gain = 1)

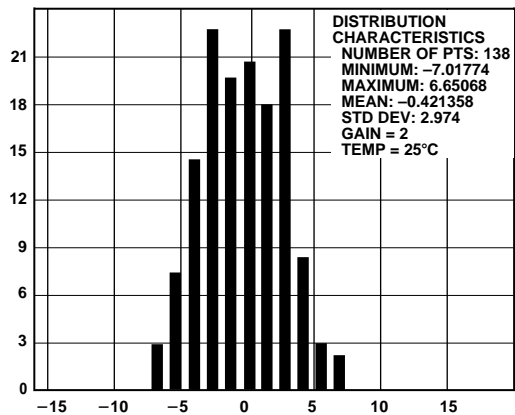

TPC 13. Channel 1 Offset Distribution (Gain = 2)

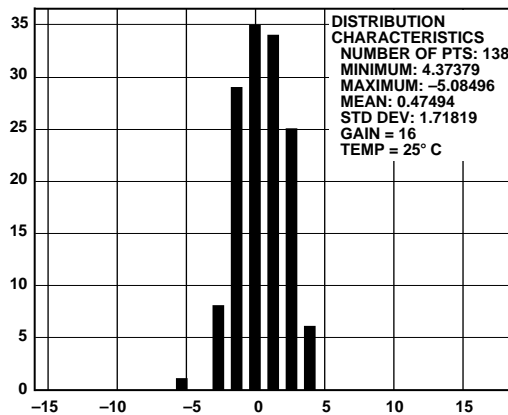

TPC 15. Channel 1 Offset Distribution (Gain = 16)

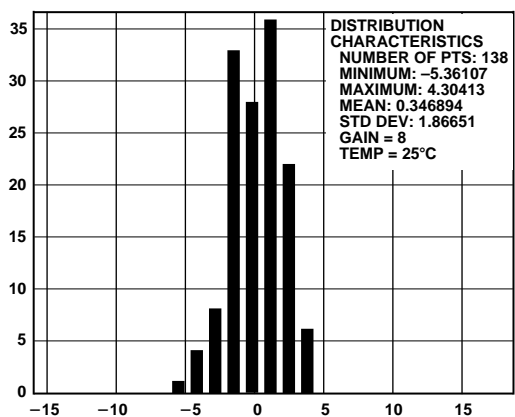

TPC 14. Channel 1 Offset Distribution (Gain = 8)

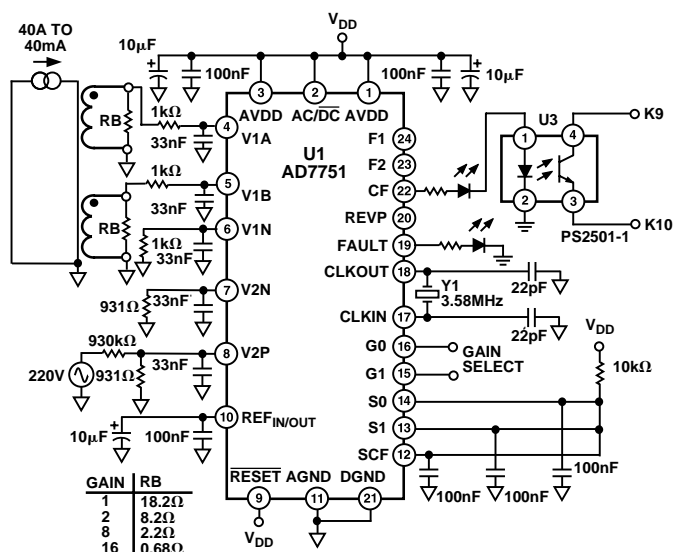

TPC 16. Test Circuit for Performance Curves

THEORY OF OPERATION

The two ADCs digitize the voltage and current signals from the current and voltage transducers. These ADCs are 16-bit second order sigma-delta converters with an oversampling rate of 900 kHz. This analog input structure greatly simplifies transducer interfacing by providing a wide dynamic range for direct connection to the transducer and also simplifying the antialiasing filter design. A programmable gain stage in the current channel further facilitates easy transducer interfacing. A high-pass filter in the current channel removes any dc component from the current signal. This eliminates any inaccuracies in the real-power calculation due to offsets in the voltage or current signals—see HPF and Offset Effects section.

The real-power calculation is derived from the instantaneous power signal. The instantaneous power signal is generated by a direct multiplication of the current and voltage signals. In order to extract the real-power component (i.e., the dc component) the instantaneous power signal is low-pass filtered. Figure 2 illustrates the instantaneous real-power signal and shows how the real-power information can be extracted by low-pass filtering the instantaneous power signal. This scheme correctly calculates real-power for nonsinusoidal current and voltage waveforms at all power factors. All signal processing is carried out in the digital domain for superior stability over temperature and time.

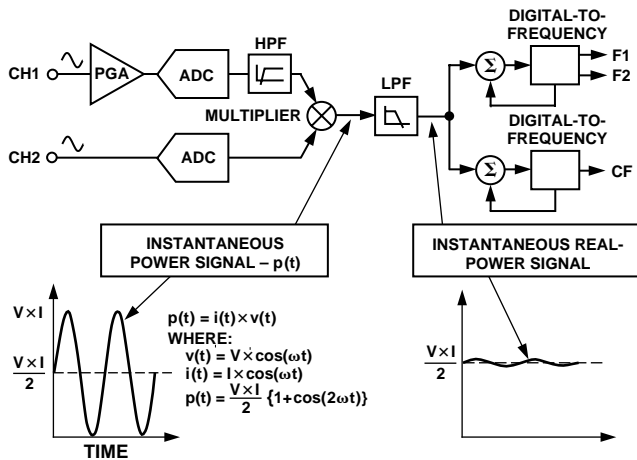

Figure 2. Signal Processing Block Diagram

The low frequency output of the AD7751 is generated by accumulating this real-power information. This low frequency inherently means a long accumulation time between output pulses. The output frequency is therefore proportional to the average real-power. This average real-power information can in turn be accumulated (e.g., by a counter) to generate real-energy information. Because of its high output frequency and hence shorter integration time, the CF output is proportional to the instantaneous real-power. This is useful for system calibration purposes that would take place under steady load conditions.

Power Factor Considerations

The method used to extract the real-power information from the instantaneous power signal (i.e., by low-pass filtering) is still valid even when the voltage and current signals are not in phase. Figure 3 displays the unity power factor condition and a DPF (Displacement Power Factor) = 0.5, i.e., current signal lagging the voltage by 60°. If we assume the voltage and current waveforms

are sinusoidal, the real-power component of the instantaneous power signal (i.e., the dc term) is given by:

$$\left(\frac{V \times I}{2}\right) \times \cos(60^\circ) \tag{1}$$

This is the correct real-power calculation.

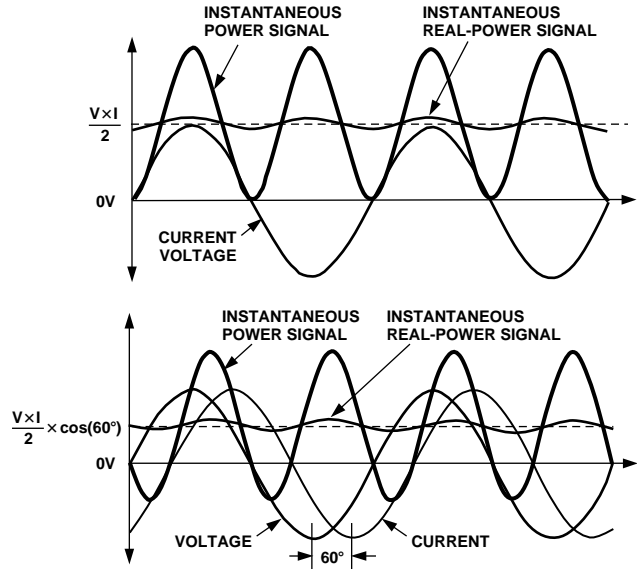

Figure 3. DC Component of Instantaneous Power Signal Conveys Real-Power Information PF < 1

Nonsinusoidal Voltage and Current

The real-power calculation method also holds true for nonsinusoidal current and voltage waveforms. All voltage and current waveforms in practical applications will have some harmonic content. Using the Fourier Transform, instantaneous voltage and current waveforms can be expressed in terms of their harmonic content.

$$v(t) = V_o + \sqrt{2} \times \sum_{h \neq 0}^{\infty} V_h \times \sin(h\omega t + \alpha_h) \tag{2}$$

where:

- $v(t)$ is the instantaneous voltage
- V_o is the average value
- V_h is the rms value of voltage harmonic h
- and
- α_h is the phase angle of the voltage harmonic.

$$i(t) = I_o + \sqrt{2} \times \sum_{h \neq 0}^{\infty} I_h \times \sin(h\omega t + \beta_h) \tag{3}$$

where:

- $i(t)$ is the instantaneous current
- I_o is the dc component
- I_h is the rms value of current harmonic h
- and
- β_h is the phase angle of the current harmonic.

Using Equations 2 and 3, the real-power P can be expressed in terms of its fundamental real power (P_1) and harmonic real power (P_H).

$$P = P_1 + P_H$$

where:

$$P_1 = V_1 \times I_1 \cos(\phi_1) \tag{4}$$

$$\phi_1 = \alpha_1 - \beta_1$$

$$\text{and } P_H = \sum_{h \neq 1}^{\infty} V_h \times I_h \times \cos(\phi_h) \tag{5}$$

$$\phi_h = \alpha_h - \beta_h$$

As can be seen from Equation 5 above, a harmonic real-power component is generated for every harmonic, provided that harmonic is present in both the voltage and current waveforms. The power factor calculation has previously been shown to be accurate in the case of a pure sinusoid, therefore the harmonic real power must also correctly account for power factor since it is made up of a series of pure sinusoids.

Note that the input bandwidth of the analog inputs is 14 kHz with a master clock frequency of 3.5795 MHz.

ANALOG INPUTS

Channel V2 (Voltage Channel)

The output of the line voltage transducer is connected to the AD7751 at this analog input. Channel V2 is a fully differential voltage input. The maximum peak differential signal on Channel 2 is ± 660 mV. Figure 4 illustrates the maximum signal levels that can be connected to the AD7751 Channel 2.

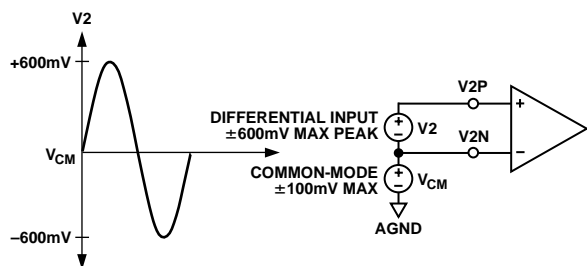

Figure 4. Maximum Signal Levels, Channel 2

Channel 2 must be driven from a common-mode voltage; i.e., the differential voltage signal on the input must be referenced to a common mode (usually AGND). The analog inputs of the AD7751 can be driven with common-mode voltages of up to 100 mV with respect to AGND. However, best results are achieved using a common mode equal to AGND.

Channel V1 (Current Channel)

The voltage outputs from the current transducers are connected to the AD7751 here. Channel V1 has two voltage inputs, namely V1A and V1B. These inputs are fully differential with respect to V1N. However, at any one time only one is selected to perform the power calculation—see Fault Detection section.

The analog inputs V1A, V1B, and V1N have the same maximum signal level restrictions as V2P and V2N. However, Channel 1 has a programmable gain amplifier (PGA) with user-selectable gains of 1, 2, 8, or 16—see Table I. These gains facilitate easy transducer interfacing.

Figure 5 illustrates the maximum signal levels on V1A, V1B, and V1N. The maximum differential voltage is ± 660 mV divided by the gain selection. Again, the differential voltage signal on the inputs must be referenced to a common mode, e.g., AGND. The maximum common-mode signal is ± 100 mV as shown in Figure 5.

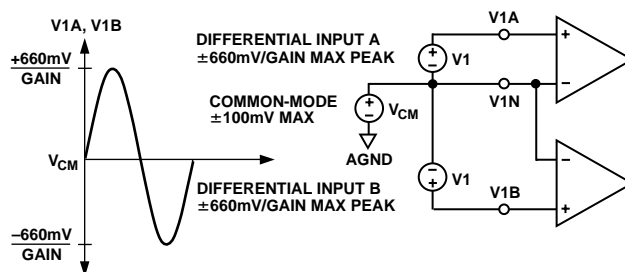

Figure 5. Maximum Signal Levels, Channel 1

Table I.

G1	G0	Gain	Maximum Differential Signal
0	0	1	± 660 mV
0	1	2	± 330 mV
1	0	8	± 82 mV
1	1	16	± 41 mV

Typical Connection Diagrams

Figure 6 shows a typical connection diagram for Channel V1. Here the analog inputs are being used to monitor both the phase and neutral currents. Because of the large potential difference between the phase and neutral, two CTs (current transformers) must be used to provide the isolation. Notice both CTs are referenced to AGND (analog ground), hence the common-mode voltage is 0 V. The CT turns ratio and burden resistor (R_b) are selected to give a peak differential voltage of ± 660 mV/Gain.

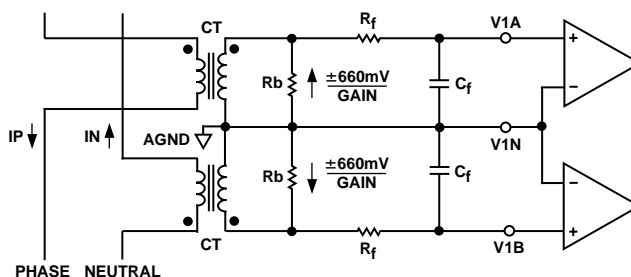

Figure 6. Typical Connection for Channel 1

AD7751

Figure 7 shows two typical connections for Channel V2. The first option uses a PT (Potential Transformer) to provide complete isolation from the mains voltage. In the second option the AD7751 is biased around the neutral wire and a resistor divider is used to provide a voltage signal that is proportional to the line voltage. Adjusting the ratio of Ra and Rb is also a convenient way of carrying out a gain calibration on the meter.

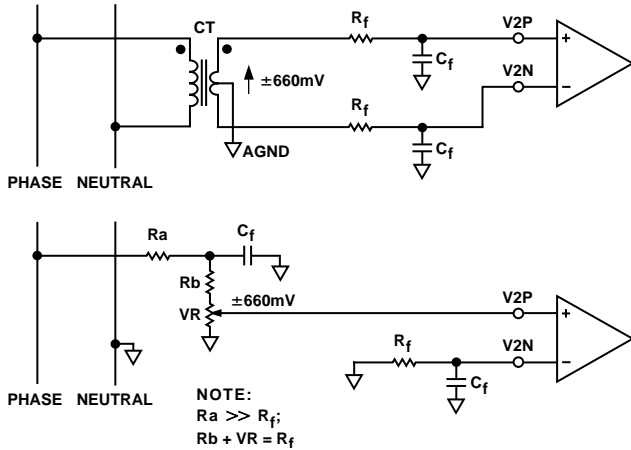

Figure 7. Typical Connections for Channel 2

POWER SUPPLY MONITOR

The AD7751 contains an on-chip power supply monitor. The analog supply (AV_{DD}) is continuously monitored by the AD7751. If the supply is less than 4 V ± 5%, the AD7751 will be reset. This is useful to ensure correct device start-up at power-up and power-down. The power supply monitor has built-in hysteresis and filtering. This gives a high degree of immunity to false triggering due to noisy supplies.

As can be seen from Figure 8 the trigger level is nominally set at 4 V. The tolerance on this trigger level is about ±5%. The power supply and decoupling for the part should be such that the ripple at AV_{DD} does not exceed 5 V ± 5% as specified for normal operation.

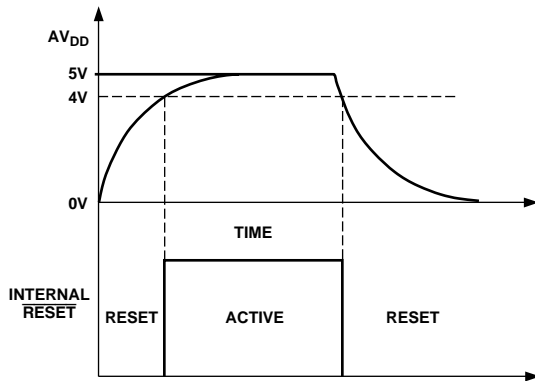

Figure 8. On-Chip Power Supply Monitor

HPF and Offset Effects

Figure 9 shows the effect of offsets on the real-power calculation. As can be seen from Figure 9, an offset on Channel 1 and Channel 2 will contribute a dc component after multiplication. Since this dc component is extracted by the LPF and used to generate the real-power information, the offsets will have contributed a constant error to the real power calculation. This problem is easily avoided by enabling the HPF (i.e., pin AC/DC is set logic high) in Channel 1. By removing the offset from at least one channel, no error component can be generated at dc by the multiplication. Error terms at cos(ωt) are removed by the LPF and the digital-to-frequency conversion—see Digital-to-Frequency Conversion section.

$$\begin{aligned} (V \cos(\omega t) + V_{OS}) \times (I \times \cos(\omega t) + I_{OS}) = \\ \frac{V \times I}{2} + V_{OS} \times I_{OS} + V_{OS} \times I \times \cos(\omega t) \\ + V \times I_{OS} \times \cos(\omega t) + \frac{V \times I}{2} \times \cos(2\omega t) \end{aligned}$$

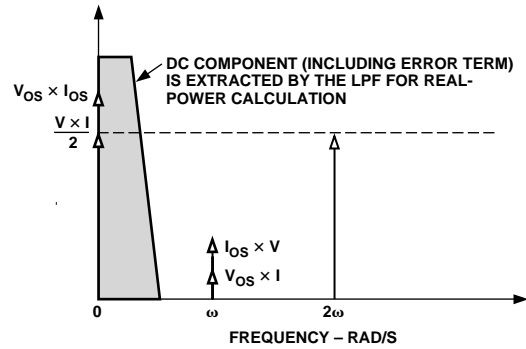

Figure 9. Effect of Channel Offsets on the Real Power Calculation

The HPF in Channel 1 has an associated phase response that is compensated for on-chip. The phase compensation is activated when the HPF is enabled and is disabled when the HPF is not activated. Figures 10 and 11 show the phase-error between channels with the compensation network activated. The AD7751 is phase compensated up to 1 kHz as shown. This will ensure correct active harmonic power calculation even at low power factors.

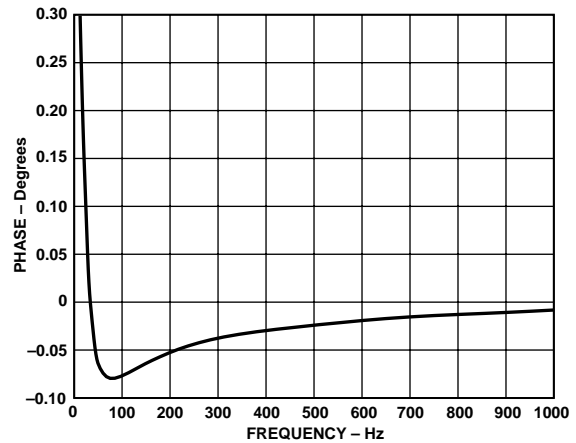

Figure 10. Phase Error Between Channels (0 Hz to 1 kHz)

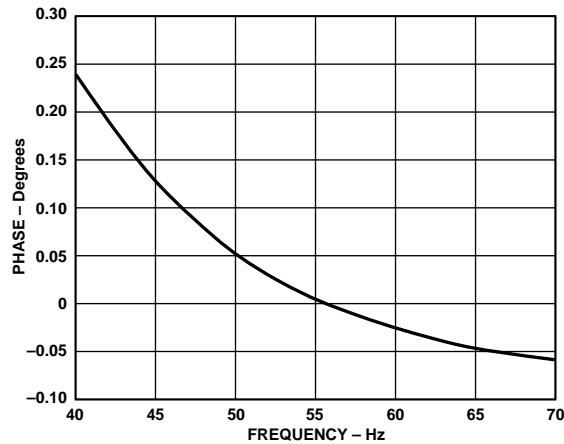

Figure 11. Phase Error Between Channels (40 Hz to 70 Hz)

DIGITAL-TO-FREQUENCY CONVERSION

As previously described, the digital output of the low-pass filter after multiplication contains the real-power information. However, since this LPF is not an ideal “brick wall” filter implementation, the output signal also contains attenuated components at the line frequency and its harmonics, i.e., $\cos(h\omega t)$ where $h = 1, 2, 3, \dots$ etc.

The magnitude response of the filter is given by:

$$|H(f)| = \frac{1}{1 + (f/8.9 \text{ Hz})^2} \quad (6)$$

For a line frequency of 50 Hz, this would give an attenuation of the 2ω (100 Hz) component of approximately -22 dBs. The dominating harmonic will be at twice the line frequency, i.e., $\cos(2\omega t)$ and this is due to the instantaneous power signal.

Figure 12 shows the instantaneous real-power signal output of LPF which still contains a significant amount of instantaneous power information, i.e., $\cos(2\omega t)$. This signal is then passed to the digital-to-frequency converter where it is integrated (accumulated) over time in order to produce an output frequency. This accumulation of the signal will suppress or average out any non-DC components in the instantaneous real-power signal. The average value of a sinusoidal signal is zero. Hence the frequency generated by the AD7751 is proportional to the average real power. Figure 12 shows the digital-to-frequency conversion for steady load conditions, i.e., constant voltage and current.

As can be seen in the diagram, the frequency output CF is seen to vary over time, even under steady load conditions. This frequency variation is primarily due to the $\cos(2\omega t)$ component in the instantaneous real-power signal. The output frequency on CF can be up to 128 times higher than the frequency on F1 and F2. This higher output frequency is generated by accumulating the instantaneous real-power signal over a much shorter time while converting it to a frequency. This shorter accumulation period means less averaging of the $\cos(2\omega t)$ component. As a consequence, some of this instantaneous power signal passes through the digital-to-frequency conversion. This will not be a problem in the application. Where CF is used for calibration purposes, the frequency should be averaged by the frequency counter. This will remove any ripple. If CF is being used to measure energy, e.g., in a microprocessor-based application, the CF output should also be averaged to calculate power. However, if an energy measurement is being made by counting pulses, no averaging is

required. Because the outputs F1 and F2 operate at a much lower frequency, a lot more averaging of the instantaneous real-power signal is carried out. The result is a greatly attenuated sinusoidal content and a virtually ripple-free frequency output.

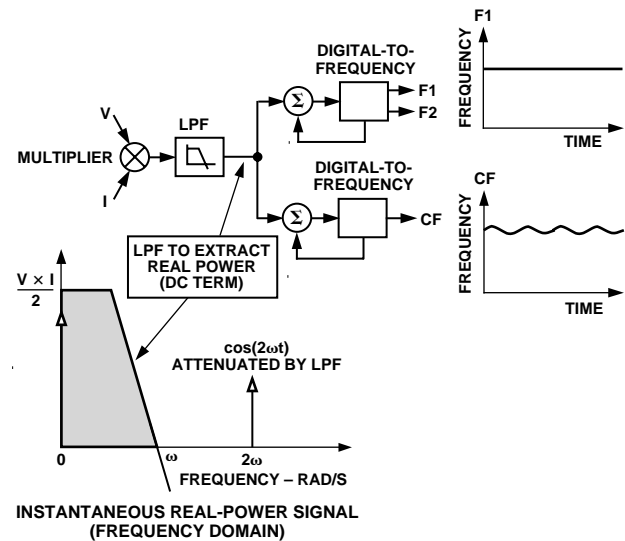

Figure 12. Real-Power-to-Frequency Conversion

FAULT DETECTION

The AD7751 incorporates a novel fault detection scheme that warns of fault conditions and allows the AD7751 to continue accurate billing during a fault event. The fault detection function is designed to work over a line frequency of 45 Hz to 55 Hz. The AD7751 does this by continuously monitoring both the phase and neutral (return) currents. A fault is indicated when these currents differ by more than 12.5%. However, even during a fault the output pulse rate on F1 and F2 is generated using the larger of the two currents. Because the AD7751 looks for a difference between the signals on V1A and V1B, it is important that both current transducers are closely matched.

On power-up the output pulse rate of the AD7751 is proportional to the product of the signals on Channel V1A and Channel 2. If there is a difference of greater than 12.5% between V1A and V1B on power-up, the fault indicator (FAULT) will go active after about one second. In addition, if V1B is greater than V1A the AD7751 will select V1B as the input. The fault detection is automatically disabled when the voltage signal on Channel 1 is less than 0.5% of the full-scale input range. This will eliminate false detection of a fault due to noise at light loads.

Fault with Active Input Greater than Inactive Input

If V1A is the active current input (i.e., is being used for billing), and the signal on V1B (inactive input) falls by more than 12.5% of V1A, the fault indicator will go active. Both analog inputs are filtered and averaged to prevent false triggering of this logic output. As a consequence of the filtering, there is a time delay of approximately one second on the logic output FAULT after the fault event. The FAULT logic output is independent of any activity on outputs F1 or F2. Figure 13 illustrates one condition under which FAULT becomes active. Since V1A is the active input and it is still greater than V1B, billing is maintained on V1A, i.e., no swap to the V1B input will occur. V1A remains the active input.

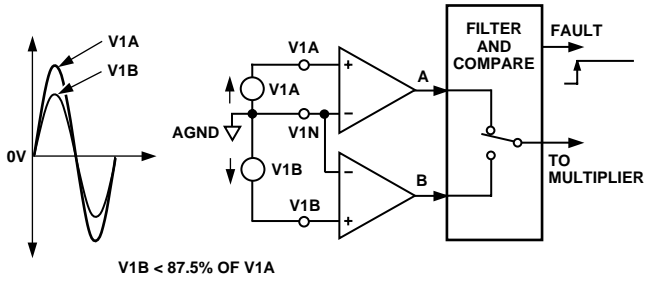

Figure 13. Fault Conditions for Inactive Input Less than Active Input

Fault with V1B Greater than V1A

Figure 14 illustrates another fault condition. If V1A is the active input (i.e., is being used for billing), and the voltage signal on V1B (inactive input) becomes greater than 114% of V1A, the FAULT indicator goes active and there is also a swap over to the V1B input. The analog input V1B has now become the active input. Again there is a time delay of about 1.2 second associated with this swap. V1A will not swap back to being the active channel until V1A becomes greater than 114% of V1B. However, the FAULT indicator will become inactive as soon as V1A is within 12.5% of V1B. This threshold eliminates potential chatter between V1A and V1B.

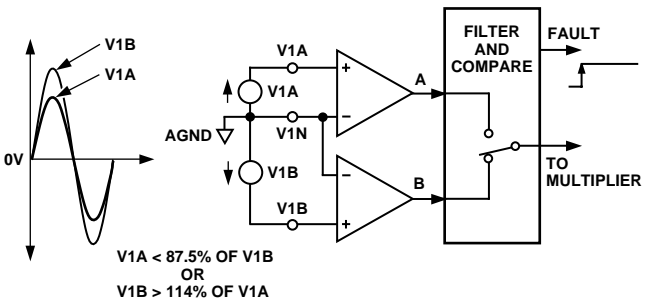

Figure 14. Fault Conditions for Inactive Input Greater than Active Input

Calibration Concerns

Typically, when a meter is being calibrated, the voltage and current circuits are separated as shown in Figure 15. This means that current will only pass through the phase or neutral circuit. Figure 15 shows current being passed through the phase circuit. This is the preferred option since the AD7751 starts billing on the input V1A on power-up. The phase circuit CT is connected to V1A in the diagram. Since there is no current in the neutral circuit the FAULT indicator will come on under these conditions. However, this does not affect the accuracy of the calibration and can be used as a means to test the functionality of the fault detection

If the neutral circuit is chosen for the current circuit in the arrangement shown in Figure 15, it may have implications for the calibration accuracy. The AD7751 will power up with the V1A input active as normal. However, since there is no current in the phase circuit, the signal on V1A is zero. This will cause a FAULT to be flagged and the active input to be swapped to V1B (Neutral). The meter may be calibrated in this mode but the phase and neutral CTs may differ slightly. Since under no-fault conditions all billing is carried out using the phase CT, the meter should be calibrated using the phase circuit. Of course, both phase and neutral circuits may be calibrated.

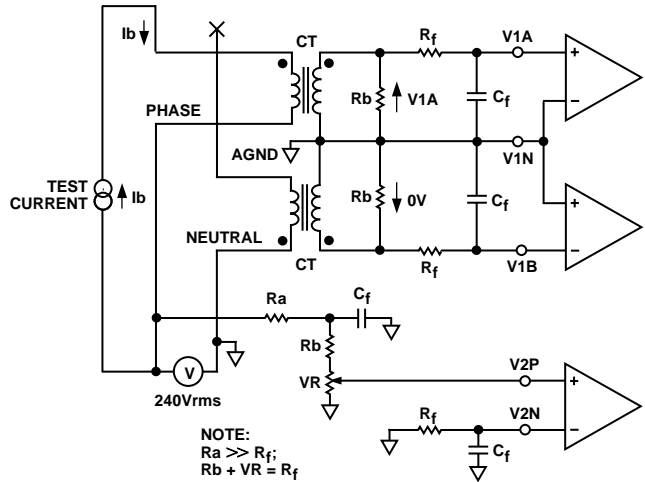

Figure 15. Fault Conditions for Inactive Input Greater than Active Input

TRANSFER FUNCTION

Frequency Outputs F1 and F2

The AD7751 calculates the product of two voltage signals (on Channel 1 and Channel 2) and then low-pass filters this product to extract real-power information. This real-power information is then converted to a frequency. The frequency information is output on F1 and F2 in the form of active low pulses. The pulse rate at these outputs is relatively low, e.g., 0.34 Hz maximum for ac signals with S0 = S1 = 0 (see Table III). This means that the frequency at these outputs is generated from real-power information accumulated over a relatively long period of time. The result is an output frequency that is proportional to the average real power. The averaging of the real-power signal is implicit to the digital-to-frequency conversion. The output frequency or pulse rate is related to the input voltage signals by the following equation.

$$Freq = \frac{5.74 \times V1 \times V2 \times Gain \times F_{1-4}}{V_{REF}^2} \tag{7}$$

where,

- Freq = Output frequency on F1 and F2 (Hz)
- V1 = Differential rms voltage signal on Channel 1 (volts)
- V2 = Differential rms voltage signal on Channel 2 (volts)
- Gain = 1, 2, 8, or 16, depending on the PGA gain selection made using logic inputs G0 and G1
- VREF = The reference voltage (2.5 V ± 8%) (volts)
- F₁₋₄ = One of four possible frequencies selected by using the logic inputs S0 and S1 (see Table II)

Table II.

S1	S0	F ₁₋₄ (Hz)	XTAL/CLKIN*
0	0	1.7	3.579 MHz/2 ²¹
0	1	3.4	3.579 MHz/2 ²⁰
1	0	6.8	3.579 MHz/2 ¹⁹
1	1	13.6	3.579 MHz/2 ¹⁸

*F₁₋₄ are a binary fraction of the master clock and will thus vary if the specified CLKIN frequency is altered.

Example 1

If full-scale differential dc voltages of +660 mV and -660 mV are applied to V1 and V2 respectively (660 mV is the maximum differential voltage that can be connected to Channel 1 and Channel 2), the expected output frequency is calculated as follows.

$$\begin{aligned} \text{Gain} &= 1, G_0 = G_1 = 0 \\ F_{1-4} &= 1.7 \text{ Hz}, S_0 = S_1 = 0 \\ V_1 &= +660 \text{ mV dc} = 0.66 \text{ volts (rms of dc} = \text{dc)} \\ V_2 &= -660 \text{ mV dc} = 0.66 \text{ volts (rms of dc} = |\text{dc}|) \\ V_{\text{REF}} &= 2.5 \text{ V (nominal reference value).} \end{aligned}$$

NOTE: If the on-chip reference is used, actual output frequencies may vary from device to device due to reference tolerance of $\pm 8\%$.

$$F_{\text{req}} = \frac{5.74 \times 0.66 \times 0.66 \times 1 \times 1.7 \text{ Hz}}{2.5^2} = 0.68 \text{ Hz} \quad (8)$$

Example 2

In this example, if ac voltages of ± 660 mV peak are applied to V1 and V2, the expected output frequency is calculated as follows.

$$\begin{aligned} \text{Gain} &= 1, G_0 = G_1 = 0 \\ F_{1-4} &= 1.7 \text{ Hz}, S_0 = S_1 = 0 \\ V_1 &= \text{rms of } 660 \text{ mV peak ac} = 0.66/\sqrt{2} \text{ volts} \\ V_2 &= \text{rms of } 660 \text{ mV peak ac} = 0.66/\sqrt{2} \text{ volts} \\ V_{\text{REF}} &= 2.5 \text{ V (nominal reference value).} \end{aligned}$$

NOTE: If the on-chip reference is used, actual output frequencies may vary from device to device due to reference tolerance of $\pm 8\%$.

$$F_{\text{req}} = \frac{5.74 \times 0.66 \times 0.66 \times 1 \times 1.7 \text{ Hz}}{\sqrt{2} \times \sqrt{2} \times 2.5^2} = 0.34 \text{ Hz} \quad (9)$$

As can be seen from these two example calculations, the maximum output frequency for ac inputs is always half of that for dc input signals. Table III shows a complete listing of all maximum output frequencies.

Table III.

S1	S0	Max Frequency for DC Inputs (Hz)	Max Frequency for AC Inputs (Hz)
0	0	0.68	0.34
0	1	1.36	0.68
1	0	2.72	1.36
1	1	5.44	2.72

Frequency Output CF

The pulse output CF (Calibration Frequency) is intended for use during calibration. The output pulse rate on CF can be up to 128 times the pulse rate on F1 and F2. The lower the F_{1-4} frequency selected the higher the CF scaling. Table IV shows how the two frequencies are related depending on the states of the logic inputs S0, S1, and SCF. Because of its relatively high pulse rate, the frequency at this logic output is proportional to the instantaneous real power. As is the case with F1 and F2, the frequency is derived from the output of the low-pass filter after multiplication. However, because the output frequency is high, this real-power information is accumulated over a much shorter time. Hence less averaging is carried out in the digital-to-frequency conversion. With much less averaging of the real-power signal, the CF output is much more responsive to power fluctuations (see Signal Processing Block in Figure 2).

Table IV.

SCF	S1	S0	F_{1-4} (Hz)	CF Max for AC Signals (Hz)
1	0	0	1.7	$128 \times F_1, F_2 = 43.52$
0	0	0	1.7	$64 \times F_1, F_2 = 21.76$
1	0	1	3.4	$64 \times F_1, F_2 = 43.52$
0	0	1	3.4	$32 \times F_1, F_2 = 21.76$
1	1	0	6.8	$32 \times F_1, F_2 = 43.52$
0	1	0	6.8	$16 \times F_1, F_2 = 21.76$
1	1	1	13.6	$16 \times F_1, F_2 = 43.52$
0	1	1	13.6	$8 \times F_1, F_2 = 21.76$

SELECTING A FREQUENCY FOR AN ENERGY METER APPLICATION

As shown in Table II, the user can select one of four frequencies. This frequency selection determines the maximum frequency on F1 and F2. These outputs are intended to be used to drive the energy register (electromechanical or other). Since only four different output frequencies can be selected, the available frequency selection has been optimized for a meter constant of 100 imp/kWhr with a maximum current of between 10 A and 120 A. Table V shows the output frequency for several maximum currents (I_{MAX}) with a line voltage of 220 V. In all cases the meter constant is 100 imp/kWhr.

Table V.

I_{MAX}	F1 and F2 (Hz)
12.5 A	0.076
25 A	0.153
40 A	0.244
60 A	0.367
80 A	0.489
120 A	0.733

The F_{1-4} frequencies allow complete coverage of this range of output frequencies on F1 and F2. When designing an energy meter, the nominal design voltage on Channel 2 (voltage) should be set to half-scale to allow for calibration of the meter constant. The current channel should also be no more than half-scale when the meter sees maximum load. This will allow over-current signals and signals with high crest factors to be accommodated. Table VI shows the output frequency on F1 and F2 when both analog inputs are half-scale. The frequencies listed in Table VI align very well with those listed in Table V for maximum load.

Table VI.

S1	S0	F_{1-4}	Frequency on F1 and F2 – CH1 and CH2 Half-Scale AC Inputs
0	0	1.7	0.085 Hz
0	1	3.4	0.17 Hz
1	0	6.8	0.34 Hz
1	1	13.6	0.68 Hz

AD7751

When selecting a suitable F_{1-4} frequency for a meter design, the frequency output at I_{MAX} (maximum load) with a meter constant of 100 imp/kWhr should be compared with Column 4 of Table VI. The frequency that is closest in Table VI will determine the best choice of frequency (F_{1-4}). For example if a meter with a maximum current of 25 A is being designed, the output frequency on F1 and F2, with a meter constant of 100 imp/kWhr, is 0.153 Hz at 25 A and 220 V (from Table V). Looking at Table VI, the closest frequency to 0.153 Hz in column four is 0.17 Hz. Therefore F_2 (3.4 Hz—see Table II) is selected for this design.

Frequency Outputs

Figure 1 shows a timing diagram for the various frequency outputs. The outputs F1 and F2 are the low frequency outputs that can be used to directly drive a stepper motor or electromechanical impulse counter. The F1 and F2 outputs provide two alternating low going pulses. The pulsewidth (t_1) is set at 275 ms and the time between the falling edges of F1 and F2 (t_3) is approximately half the period of F1 (t_2).

If, however, the period of F1 and F2 falls below 550 ms (1.81 Hz), the pulsewidth of F1 and F2 is set to half of their period. The maximum output frequencies for F1 and F2 are shown in Table III.

The high-frequency CF output is intended to be used for communications and calibration purposes. CF produces a 90-ms-wide active high pulse (t_4) at a frequency that is proportional to active power. The CF output frequencies are given in Table IV. As in the case of F1 and F2, if the period of CF (t_5) falls below 180 ms, the CF pulsewidth is set to half the period. For example, if the CF frequency is 20 Hz, the CF pulsewidth is 25 ms.

NO LOAD THRESHOLD

The AD7751 also includes a “no load threshold” and “start-up current” feature that will eliminate any creep effects in the meter. The AD7751 is designed to issue a minimum output frequency. Any load generating a frequency lower than this minimum frequency will not cause a pulse to be issued on F1, F2, or CF. The minimum output frequency is given as 0.0014% of the full-scale output frequency for each of the F_{1-4} frequency selections (see Table II). For example, an energy meter with a meter constant of 100 imp/kWhr on F1, F2 using F_2 (3.4 Hz), the maximum output frequency at F1 or F2 would be 0.0014% of 3.4 Hz or 4.76×10^{-5} Hz. This would be 3.05×10^{-3} Hz at CF ($64 \times F1$ Hz). In this example the no load threshold would be equivalent to 1.7 W of load or a start-up current of 8 mA at 220 V. Comparing this value to the IEC1036 specification, which states that the meter must start up with a load equal to or less than 0.4% I_b . For a 5 A(I_b) meter 0.4% of I_b is equivalent to 20 mA.

C01194-0-10/01(B)

OUTLINE DIMENSIONS

Dimensions shown in inches and (mm).

24-Lead Plastic DIP (N-24)

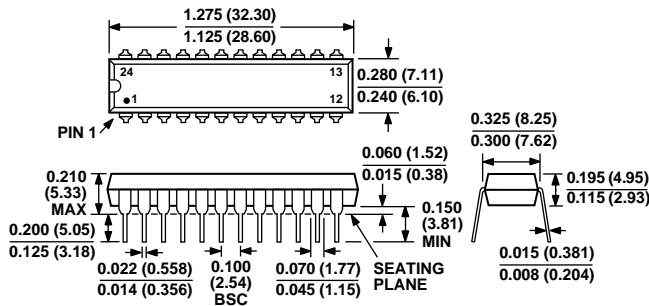

24-Shrink Small Outline Package (RS-24)

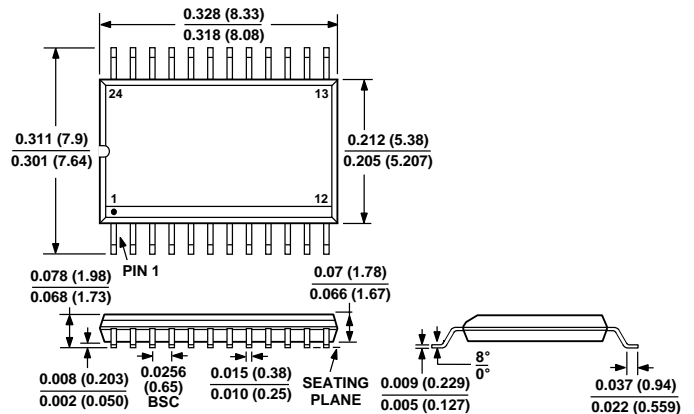

Revision History

Location	Page
Data Sheet changed from REV. A to REV. B.	
Changes to Specifications table	2

PRINTED IN U.S.A.