

# BQ79606A-Q1 SafeTI™ Precision Monitor With Integrated Hardware Protector for Automotive Battery Pack Applications

## 1 Features

- Qualified for automotive applications
- AEC-Q100 Qualified with the following results:
  - Device temperature grade 2:  $-40^{\circ}\text{C}$  to  $+105^{\circ}\text{C}$  ambient operating temperature range
  - Device HBM ESD classification level 2
  - Device CDM ESD classification level C4B
- Voltage monitor, temperature monitor and communication functions: SafeTI™-26262 ASIL-D compliant
- $\pm 1.1\text{mV}$  Cell voltage measurement accuracy with an offset
- Configurable digital low pass filter as low as 1.2Hz
- Supports simultaneous cell voltage measurements
  - Full-accuracy stack measurements in less than 1 ms (for 96 cells)
- Optional ring architecture to ensure stack communication even with communication cable break
- Monitors 3 to 6 cell connections and up to 6 NTC/auxiliary channels
  - Integrated 16-bit analog-to-digital converters (ADC)
- Integrated high-voltage AFE filter components
- Designed for robust hot-plug performance
- Stackable configuration up to 64 devices (1 base + 63 stack, 384-series cells)
- Isolated differential daisy chain communication
  - Supports transformer or capacitor based isolation
- Configurable SINC<sup>3</sup> digital filter
- Integrated hardware protector
  - Secondary protection for cell overtemperature and undertemperature
  - Secondary protection for cell overvoltage and undervoltage
- Hardware protector function: SafeTI™-26262 ASIL-B compliant
- Integrated cell-balancing MOSFET's up to 150 mA
- Designed to pass BCI testing
- UART Host interface

## 2 Applications

- Full electric, plug-in hybrid, and hybrid vehicles
- Automotive 12-V and 48-V Li-Ion battery systems
- Grid storage battery systems
- Uninterruptible power supplies (UPS)
- E-Bikes, E-Scooters

## 3 Description

The BQ79606A-Q1 device provides simultaneous, high accuracy, channel measurements for three to six battery cells. With the inclusion of a daisy chain communication port, the BQ79606A-Q1 device is stackable (up to 64 devices) to support the large stack configurations found in battery packs for electrified automotive drive trains. Providing a Delta Sigma converter per cell input, the BQ79606A-Q1 allows simultaneous measurement of the battery voltages.

The BQ79606A-Q1 includes an auxiliary ADC that supports cell temperature measurements for up to six NTCs as well as internal rails to enable safety checks for the device. A die temperature measurement ADC is also included to provide temperature correction to enable high accuracy results over an extended temperature range.

### Device Information<sup>(1)</sup>

PART NUMBER	PACKAGE	BODY SIZE (NOM)
BQ79606A-Q1	PQFP (48 pin)	7.00 mm × 7.00 mm

(1) For all available packages, see the orderable addendum at the end of the data sheet.

### Simplified System Diagram

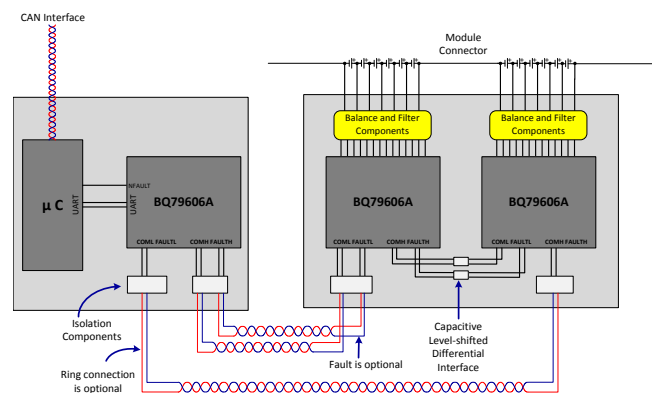

## Table of Contents

<b>1 Features</b> .....	<b>1</b>	8.6 Register Maps .....	<b>91</b>
<b>2 Applications</b> .....	<b>1</b>	<b>9 Application and Implementation</b> .....	<b>228</b>
<b>3 Description</b> .....	<b>1</b>	9.1 Application Information.....	<b>228</b>
<b>4 Revision History</b> .....	<b>2</b>	9.2 Typical Applications .....	<b>229</b>
<b>5 Description (continued)</b> .....	<b>3</b>	<b>10 Power Supply Recommendations</b> .....	<b>254</b>
<b>6 Pin Configuration and Functions</b> .....	<b>4</b>	10.1 Communication Bridge System.....	<b>254</b>
<b>7 Specifications</b> .....	<b>8</b>	10.2 Integrated Base Device System.....	<b>254</b>
7.1 Absolute Maximum Ratings .....	<b>8</b>	10.3 Multi-Drop System.....	<b>255</b>
7.2 ESD Ratings.....	<b>8</b>	<b>11 Layout</b> .....	<b>257</b>
7.3 Recommended Operating Conditions.....	<b>8</b>	11.1 Layout Guidelines .....	<b>257</b>
7.4 Thermal Information .....	<b>9</b>	11.2 Layout Example .....	<b>258</b>
7.5 Electrical Characteristics.....	<b>9</b>	<b>12 Device and Documentation Support</b> .....	<b>260</b>
7.6 Timing Requirements.....	<b>13</b>	12.1 Receiving Notification of Documentation Updates.....	<b>260</b>
7.7 Typical Characteristics.....	<b>17</b>	12.2 Community Resource.....	<b>260</b>
<b>8 Detailed Description</b> .....	<b>18</b>	12.3 Trademarks .....	<b>260</b>
8.1 Overview .....	<b>18</b>	12.4 Electrostatic Discharge Caution.....	<b>260</b>
8.2 Functional Block Diagram .....	<b>19</b>	12.5 Glossary .....	<b>260</b>
8.3 Feature Description.....	<b>20</b>	<b>13 Mechanical, Packaging, and Orderable Information</b> .....	<b>261</b>
8.4 Device Functional Modes.....	<b>44</b>		
8.5 Communication, Programming, GPIO, and Safety ..	<b>48</b>		

## 4 Revision History

DATE	REVISION	NOTES
April 2019	*	Initial release

## 5 Description (continued)

Host communication to the BQ79606A-Q1 device is done via dedicated UART interface. Additionally, an isolated, differential daisy-chain communication interface that supports either capacitor or transformer isolation allows the host to communicate with the entire battery stack. The daisy-chain communication interface can be configured (optional) in a ring architecture that allows the host to talk to devices at either end of the stack in cases of communication line breaks.

## 6 Pin Configuration and Functions

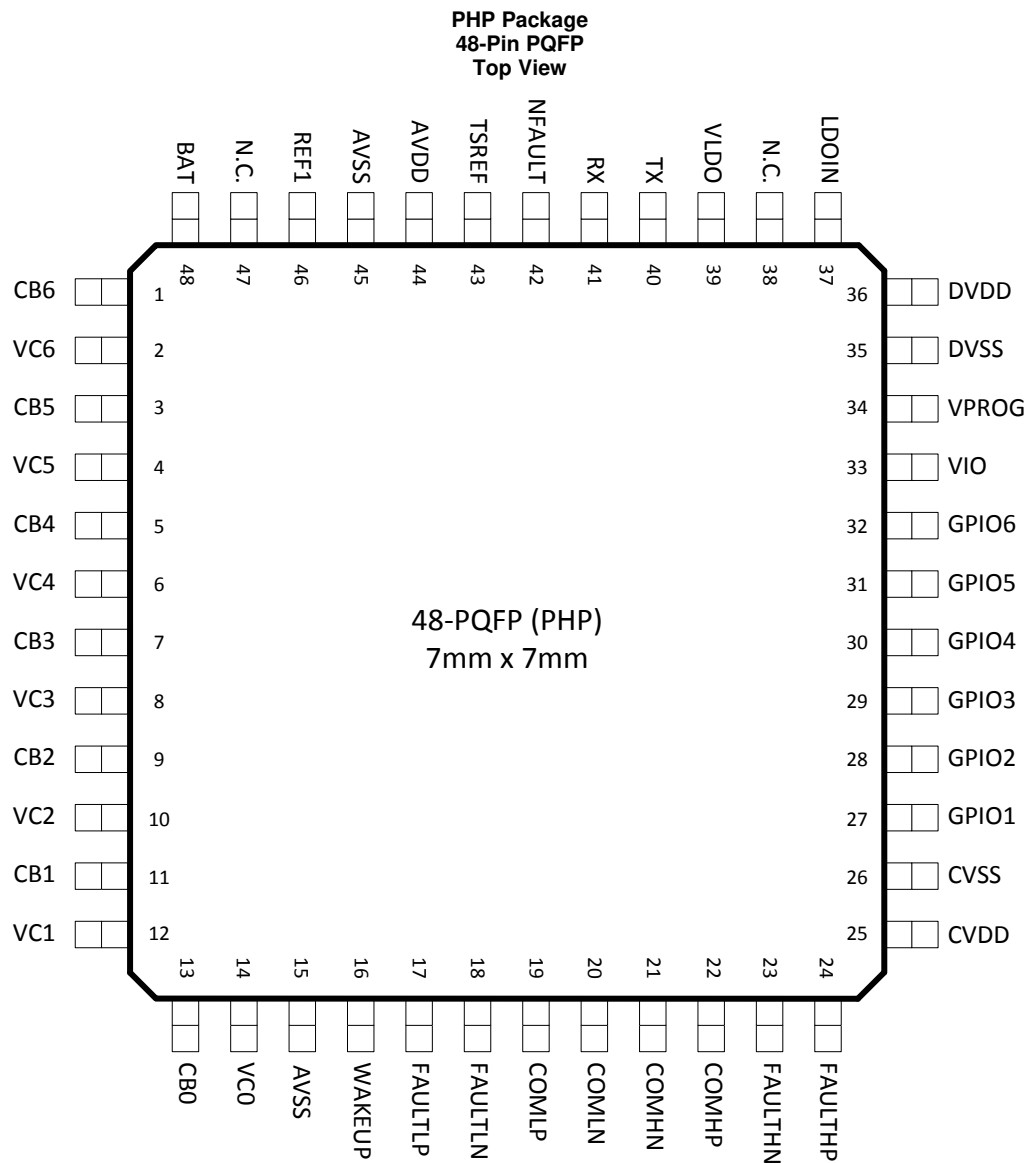

### Pin Functions

PIN		TYPE	DESCRIPTION
NAME	NO.		
AVSS	15	GND	Analog Ground. Pin 15 is not connected to pin 45 internally. Ground connection for internal analog circuits. Connect CVSS, DVSS, and AVSS externally. AVSS must NOT be left unconnected.
	45	GND	Analog Ground. Pin 45 is not connected to pin 15 internally. Ground connection for internal ADC circuits. Connect the decoupling capacitor of the REF1 to this pin. Connect CVSS, DVSS, and AVSS externally. AVSS must NOT be left unconnected.
AVDD	44	O	5-V Regulator Output. AVDD supplies internal circuits. Bypass AVDD to AVSS with 2.2µF/10V ceramic capacitor. The capacitance range after derating must fall between 1µF to 2.2µF. Do not connect additional load to AVDD.
BAT	48	I	Battery Stack Connection. Connect BAT to the positive terminal of the highest cell in the stack through a 100Ω resistor. Bypass BAT to AVSS with a 0.33µF/50V capacitor.
CB0	13	I/O	Cell Balance Connection 0. CB0 is connected to the internal balance FET. Connect CB0 to the negative terminal of cell 1 (bottom cell) through a resistor. The resistor sets the balance current. See <a href="#">Selecting Cell Balance Resistors</a> for details on calculating the resistor value. Additionally, connect a 0.47µF, 10V (or better) ceramic capacitor between CB0 and AVSS.

### Pin Functions (continued)

PIN		TYPE	DESCRIPTION
NAME	NO.		
CB1	11	I/O	Cell Balance Connection 1. CB1 is connected to the internal balance FET. Connect CB1 to the junction of the positive terminal of cell 1 (bottom cell) and the negative terminal of cell 2 through a resistor. The resistor sets the balance current. See <a href="#">Selecting Cell Balance Resistors</a> for details on calculating the resistor value. Additionally, connect a 0.47µF, 10V (or better) ceramic capacitor between CB1 and CB0. Short CB1 to CB0 if cell balancing is not used.
CB2	9	I/O	Cell Balance Connection 2. CB2 is connected to the internal balance FET. Connect CB2 to the junction of the positive terminal of cell 2 and the negative terminal of cell 3 through a resistor. The resistor sets the balance current. See <a href="#">Selecting Cell Balance Resistors</a> for details on calculating the resistor value. Additionally, connect a 0.8µF, 10V (or better) ceramic capacitor between CB2 and CB1. Short CB2 to CB1 if cell balancing is not used.
CB3	7	I/O	Cell Balance Connection 3. CB3 is connected to the internal balance FET. Connect CB3 to the junction of the positive terminal of cell 3 and the negative terminal of cell 4 through a resistor. The resistor sets the balance current. See <a href="#">Selecting Cell Balance Resistors</a> for details on calculating the resistor value. Additionally, connect a 1-µF, 10V (or better) ceramic capacitor between CB3 and CB2. Short CB3 to CB2 if cell balancing is not used.
CB4	5	I/O	Cell Balance Connection 4. CB4 is connected to the internal balance FET. Connect CB4 to the junction of the positive terminal of cell 4 and the negative terminal of cell 5 through a resistor. The resistor sets the balance current. See <a href="#">Selecting Cell Balance Resistors</a> for details on calculating the resistor value. Additionally, connect a 1-µF, 10V (or better) ceramic capacitor between CB4 and CB3. Short CB4 to CB3 if cell balancing is not used.
CB5	3	I/O	Cell Balance Connection 5. CB5 is connected to the internal balance FET. Connect CB5 to the junction of the positive terminal of cell 5 and the negative terminal of cell 6 through a resistor. The resistor sets the balance current. See <a href="#">Selecting Cell Balance Resistors</a> for details on calculating the resistor value. Additionally, connect a 0.8µF, 10V (or better) ceramic capacitor between CB5 and CB4. Short CB5 to CB4 if cell balancing is not used.
CB6	1	I/O	Cell Balance Connection 6. CB6 is connected to the internal balance FET. Connect CB6 to the positive terminal of cell 6 through a resistor. The resistor sets the balance current. See <a href="#">Selecting Cell Balance Resistors</a> for details on calculating the resistor value. Additionally, connect a 0.47µF, 10V (or better) ceramic capacitor between CB6 and CB5. Short CB6 to CB5 if cell balancing is not used.
COMHN	21	I/O	This is AC coupled I/O. Daisy Chain Communication Connections for Higher Stack Device. COMHP and COMHN provide differential communications for the daisy chain interface. Connect COMHP and COMHN to the COMLP and COMLN inputs on the next higher device in the stack. For devices separated by twisted pair cabling, the connections must be made through either capacitor or transformer isolation network. See <a href="#">Daisy-Chain Differential Bus</a> for details. Leave COMH* unconnected if not used.
COMHP	22	I/O	
COMLN	20	I/O	This is AC coupled I/O. Daisy Chain Communication Connections for Lower Stack Device. COMLP and COMLN provide differential communication for the daisy chain interface. Connect COMLP and COMLN to the COMHP and COMHN inputs on the next lower device in the stack. For devices separated by twisted pair cabling, the connections must be made through either capacitor or transformer isolation network. See <a href="#">Daisy-Chain Differential Bus</a> section for details. Leave COML* unconnected if not used.
COMLP	19	I/O	
CVDD	25	I	Daisy Chain Communication Power. CVDD is the supply input for the stack daisy chain communication transceiver circuits. Connect CVDD to VLDO through a 0Ω resistor. Bypass CVDD to CVSS with a 2.2µF/10V ceramic capacitor. The capacitance range after derating must fall between 1µF to 2.2µF (Excluding VLDO cap).
CVSS	26	GND	Daisy Chain Communication Ground. Ground connection for internal daisy chain transceivers. Connect AVSS, CVSS, and DVSS externally. CVSS must NOT be left unconnected.
DVDD	36	O	1.8-V Regulator Output. DVDD supplies internal circuits. Bypass DVDD to DVSS with a ceramic capacitor ranging from 1µF to 2.2µF with 10V rating. The capacitance range after derating must fall between 1µF to 2.2µF. Connect the capacitor as close as possible to the pin with a noise free trace. Do not connect additional load to DVDD.
DVSS	35	GND	Digital Ground. Ground connection for internal digital logic. Connect AVSS, CVSS, and DVSS externally. DVSS must NOT be left unconnected.
FAULTLP	17	O	This is AC coupled I/O. Daisy Chain Fault Connections for Lower Stack Device. FAULTLN and FAULTLP provide differential fault signaling for the daisy chain interface. Connect FAULTLP and FAULTLN to the FAULTHP and FAULTHN inputs on the next lower device in the stack. For devices separated by twisted pair cabling, the connections must be made through either capacitor or transformer isolation network. See <a href="#">Daisy-Chain Differential Bus</a> for details. Leave FAULTL* unconnected if not used.
FAULTLN	18	O	
FAULTHP	24	I	This is AC coupled I/O. Daisy Chain Fault Connections for Higher Stack Device. FAULTHN and FAULTHP provide differential communication signaling for the daisy chain interface. Connect FAULTHP and FAULTHN to the FAULTLP and FAULTLN inputs on the next higher device in the stack. For devices separated by twisted pair cabling, the connections must be made through either capacitor or transformer isolation network. See <a href="#">Daisy-Chain Differential Bus</a> section for details. Leave FAULTH* unconnected if not used.
FAULTHN	23	I	

**Pin Functions (continued)**

PIN		TYPE	DESCRIPTION
NAME	NO.		
GPIO1	27	I/O	General Purpose Input/Output. GPIO* is configurable as an input or output. GPIO* has configurable pullup and pulldown (weak) resistors. In input mode, GPIO* is configurable to indicate a fault on a high or low, or simply update register to indicate input level. Additionally, GPIO1-GPIO6 are configurable as an ADC input to measure an external temperature sensor (NTC) or other DC voltage. To monitor an external temperature sensor, connect a resistor divider from TSREF to AVSS with GPIO* connected to the center tap. The ADC reports a ratiometric result of GPIO*/TSREF. To measure a standard DC voltage, no resistor divider is required. When configured as an ADC input, GPIO1-GPIO6 support under temperature and over temperature hardware protection as well. See the <a href="#">GPIO* Inputs</a> for details on calculating the component values. GPIO1-GPIO6 also are available to be used for the programming the device address. This is most commonly used in multi-drop. Connect GPIO* to AVSS through a 10-kΩ resistor if unused.
GPIO2	28	I/O	
GPIO3	29	I/O	
GPIO4	30	I/O	
GPIO5	31	I/O	
GPIO6	32	I/O	
LDOIN	37	I	LDO Supply. LDOIN supplies the internal LDO regulators. Connect LDOIN to the positive terminal of the highest cell in the stack through a 40Ω to 50Ω resistor. Bypass LDOIN to AVSS with a 0.33μF/50V capacitor.
N.C.	47	-	No Connect. No internal connection. Leave N.C. unconnected on the board.
	38	-	
NFAULT	42	O	Active-Low Fault Indication Output. NFAULT pulls low to indicate to the external host that a fault condition has occurred. NFAULT is an open-drain output. Connect a 10KΩ to 100kΩ resistor from NFAULT to VIO. Leave NFAULT unconnected if not used.
REF1	46	O	High-Power Reference Bypass Connection. Bypass REF1 to AVSS (pin 45) with a 2.2μF (10V) ceramic capacitor. The capacitance range after derating must fall between 0.5uF to 2.2uF. Do not connect additional load to REF1. Put the cap as close as possible to the REF1 and AVSS pins and make sure the trace is noise free.
RX	41	I	UART Receiver Input. Connect a 10KΩ to 100kΩ pull up resistor from RX to VIO and connect RX to the TX output of the host micro-controller. If unused, connect RX to VIO. RX must not be left unconnected.
TSREF	43	O	Bias Voltage for NTC Monitor. Bypass TSREF to AVSS with a 2.2μF (10V or better) ceramic capacitor. The capacitance range after derating must fall between 1uF to 2.2uF. Connect TSREF to the top of the resistor divider network for the GPIOs when used in NTC monitor mode. TSREF is not available to drive any load other than the resistor network. Leave TSREF unconnected if NTC monitoring is not used.
TX	40	O	UART Transmitter Output. Connect TX to the RX input of the host micro-controller. For base devices, the TX must be pulled high on the host-side. Leave it floating if unused for stack configuration.
VC0	14	I	Cell Voltage Sense Connection 0. Connect VC0 to the negative terminal of cell 1 (bottom cell) through a resistor. See the <a href="#">VC* Inputs</a> section for details on selecting the resistor value. Connect a 0.47μF, 10V (or better) ceramic capacitor from VC0 to AVSS.
VC1	12	I	Cell Voltage Sense Connection 1. Connect VC1 to the junction of the positive terminal of cell 1 (bottom cell) and the negative terminal of cell 2 through a resistor. See the <a href="#">VC* Inputs</a> section for details on selecting the resistor value. Connect a 0.47μF, 10V (or better) ceramic capacitor from VC1 to VC0.
VC2	10	I	Cell Voltage Sense Connection 2. Connect VC2 to the junction of the positive terminal of cell 2 and the negative terminal of cell 3 through a resistor. See the <a href="#">VC* Inputs</a> section for details on selecting the resistor value. Recommend to connect a 0.8μF for better transient response, 10V (or better) ceramic capacitor from VC2 to VC1.
VC3	8	I	Cell Voltage Sense Connection 3. Connect VC3 to the junction of the positive terminal of cell 3 and the negative terminal of cell 4 through a resistor. See the <a href="#">VC* Inputs</a> section for details on selecting the resistor value. Recommend to connect a 1-μF for better transient response, 10V (or better) ceramic capacitor from VC3 to VC2.
VC4	6	I	Cell Voltage Sense Connection 4. Connect VC4 to the junction of the positive terminal of cell 4 and the negative terminal of cell 5 through a resistor. See the <a href="#">VC* Inputs</a> section for details on selecting the resistor value. Recommend to connect a 1-μF for better transient response, 10V (or better) ceramic capacitor from VC4 to VC3.
VC5	4	I	Cell Voltage Sense Connection 5. Connect VC5 to the junction of the positive terminal of cell 5 and the negative terminal of cell 6 through a resistor. See the <a href="#">VC* Inputs</a> section for details on selecting the resistor value. Recommend to connect a 0.8μF for better transient response, 10V (or better) ceramic capacitor from VC5 to VC4.
VC6	2	I	Cell Voltage Sense Connection 6. Connect VC6 to the positive terminal of cell 6 through a resistor. See the <a href="#">VC* Inputs</a> section for details on selecting the resistor value. Connect a 0.47μF, 10V (or better) ceramic capacitor from VC6 to VC5.
VIO	33	I	I/O Supply Voltage. All of the digital pins (WAKEUP, RX, TX and GPIO's) are referenced to VIO. Connect VIO to the system rail between 1.8V and 5.25V. VIO is supplied from the external system logic supply or is connected to VLDO or CVDD for stack devices (or systems without a logic supply). Bypass VIO to AVSS with a 2.2μF/10V ceramic capacitor.
VLDO	39	O	5-V Regulator Output. VLDO supplies CVDD (can be used for VIO). Bypass VLDO to AVSS with ceramic capacitor of typical value of 2.2μF/10V. The total range of the capacitance after derating can be from 1uF to 2.2uF (Excluding the CVDD cap). The start up time will increase with higher cap value of more than 2.2uF. Do not connect additional load to VLDO.
VPROG	34	I	OTP Programming Voltage. Connect 7.6 V to VPROG during OTP programming with 1uF/16V capacitor to GND. If not used, connected it to GND through a 100KΩ resistor.

**Pin Functions (continued)**

PIN		TYPE	DESCRIPTION
NAME	NO.		
WAKEUP	16	I	Wake Input for Base Device. Use WAKEUP to send WAKE and SHUTDOWN commands to devices in stand alone operation, multi-drop stacks, or the base device in a daisy chain stack. See the <a href="#">Base Device Wakeup and Hardware Shutdown</a> section for details on the process for sending the commands. WAKEUP must be pulled high during normal operation to configure the device as a base device. For stack devices, connect WAKEUP to AVSS. Do NOT leave WAKEUP unconnected.

## 7 Specifications

### 7.1 Absolute Maximum Ratings

 over operating free-air temperature range (unless otherwise noted) <sup>(1)</sup>

		MIN	MAX	UNIT
BAT, LDOIN to AVSS <sup>(2)</sup>		-0.3	36	V
BAT, LDOIN to AVSS	BAT, LDOIN to AVSS	-0.3	33	V
VC0 to AVSS	VC0 to AVSS	-0.3	5	V
VC <sub>n</sub> to AVSS (n=1 to 2)	VC <sub>n</sub> to AVSS (n=1 to 2)	-0.3	33	V
VC <sub>n</sub> to AVSS (n=3 to 6)	VC <sub>n</sub> to AVSS (n=3 to 6)	3	33	V
CB <sub>n</sub> to AVSS (n=1 to 6)	CB <sub>n</sub> to AVSS (n=1 to 6)	-0.3	33	V
CB <sub>n</sub> to AVSS (n=0)		-0.3	5	V
COMHP, COMHN, COMLP, COMLN, FAULTHP, FAULTHN, FAULTLP, FAULTLN to CVSS		-20	20	V
COMHP to COMHN, COMLP to COMLN, FAULTHP to FAULTHN, FAULTLP to FAULTLN		-5.5	5.5	V
VC(n) to VC(n-1) for n = 1 to 6		-33	33	V
CB(n) to CB(n-1) for n = 1 to 6		-0.3	16	V
GPIO*, NFAULT, RX, TX, WAKEUP to AVSS		-0.3	V <sub>VIO</sub> +0.3	V
VPROG to AVSS, during OTP programming		-0.3	7.9	V
VPROG to AVSS, OTP programming disabled		-0.3	8	V
AVDD, CVDD, REF1, TSREF, VIO, VLDO to AVSS		-0.3	6	V
DVDD to DVSS		-0.3	2.3	V
DVSS, CVSS to AVSS		-0.3	0.3	V
CB* current			175	mA
GPIO*, RX, TX current			10	mA
Ambient temperature		-40	125	°C
Junction temperature		-40	150	°C
Storage temperature, T <sub>stg</sub>			150	°C

- (1) Stresses beyond those listed under *Absolute Maximum Ratings* may cause permanent damage to the device. These are stress ratings only, which do not imply functional operation of the device at these or any other conditions beyond those indicated under *Recommended Operating Conditions*. Exposure to absolute-maximum-rated conditions for extended periods may affect device reliability.
- (2) Specified for voltage spikes less than 100µs in duration for a maximum cumulative lifetime of 1000hours above 33 V.

### 7.2 ESD Ratings

			VALUE	UNIT	
V <sub>(ESD)</sub>	Electrostatic discharge	Human-body model (HBM), per AEC Q100-002 <sup>(1)</sup>	±2000	V	
		Charged-device model (CDM), per AEC Q100-011	All pins		±500
			Corner pins (1, 12, 13, 24, 25, 36, 37, and 48)		±750

- (1) AEC Q100-002 indicates that HBM stressing shall be in accordance with the ANSI/ESDA/JEDEC JS-001 specification.

### 7.3 Recommended Operating Conditions

over operating free-air temperature range (unless otherwise noted)

		MIN	MAX	UNIT
V <sub>MODULE</sub>	Total module voltage (V <sub>BAT</sub> , V <sub>LDOIN</sub> ), full functionality available	5.5	30	V
V <sub>MODULECOM</sub>	Total module voltage (V <sub>BAT</sub> , V <sub>LDOIN</sub> ), communication bridge only	4.75	30	V
V <sub>CELL</sub>	Cell differential voltage (VC <sub>n</sub> -VC <sub>n-1</sub> , n = 1 to 6)	-2	5	V
	Cell common mode voltage (VC <sub>n</sub> -AVSS, n = 0)	0	3	V
V <sub>CELL</sub>	Cell common mode voltage (VC <sub>n</sub> -AVSS, n = 1 to 2)	0	30	V
V <sub>CELL</sub>	Cell common mode voltage (VC <sub>n</sub> -AVSS, n = 3 to 6)	3	30	V
CB	Cell Balancing pin common mode voltage (CB <sub>n</sub> -AVSS, n = 0)	0	3	V
CB	Condition 1: Cell Balancing differential voltage (CB <sub>n</sub> -CB <sub>n-1</sub> , n = 1 to 6) (meet condition 1 and 2)	0	14	V
CB	Condition 2: Cell Balancing pin common mode voltage (CB <sub>n</sub> -AVSS, n = 1 to 6) (meet condition 1 and 2)	0	30	V



## Recommended Operating Conditions (continued)

over operating free-air temperature range (unless otherwise noted)

		MIN	MAX	UNIT
V <sub>VIO</sub>	VIO input voltage	1.8	5.25	V
V <sub>PROG</sub>	PROG input voltage for OTP programming	7.4	7.8	V
	PROG input voltage all other times	0		V
V <sub>CELLBAL</sub>	Cell balancing current	5	150	mA
I <sub>IO</sub>	GPIO*, RX, TX current		3	mA
	Ambient temperature	-40	105	°C

## 7.4 Thermal Information

THERMAL METRIC		bq79606A-Q1		UNIT
		PFB (TQFP)		
		48 PINS		
R <sub>θJA</sub>	Junction-to-ambient thermal resistance	23.2		°C/W
R <sub>θJC(top)</sub>	Junction-to-case (top) thermal resistance	13		°C/W
R <sub>θJB</sub>	Junction-to-board thermal resistance	4.6		°C/W
ψ <sub>JT</sub>	Junction-to-top characterization parameter	0.1		°C/W
ψ <sub>JB</sub>	Junction-to-board characterization parameter	4.7		°C/W
R <sub>θJC(bot)</sub>	Junction-to-case (bottom) thermal resistance	0.4		°C/W

## 7.5 Electrical Characteristics

V<sub>BAT</sub> = 5.5V to 30V, all LDOs operating in regulation, Typical Applications Circuit used, 3 to 6 cells connected, -40°C to +105°C free-air temperature range (unless otherwise noted)

PARAMETER		TEST CONDITIONS	MIN	TYP	MAX	UNIT
<b>Supply Currents</b>						
I <sub>SHDN</sub>	Supply current in SHUTDOWN mode	Addition of both BAT and LDOIN supply current	30	65	105	μA
I <sub>SLEEP(IDLE)</sub>	Supply current in SLEEP mode with no functionality enabled	Cell balancing disabled	95	130	165	μA
I <sub>SLEEP(BAL)</sub>	Supply current in SLEEP mode with only cell balancing enabled	One or more cell balancing FETs turned on	700	780	850	μA
I <sub>ACT(IDLE)</sub>	Supply current in ACTIVE mode with no functionality enabled	No communication. Cell balancing disabled.	3.7	4.2	4.6	mA
I <sub>ACT(COMT)</sub>	Additional supply current during communication (Average)	Daisy-chain interface communicating, transformer isolation. There is a 1KΩ termination. Depends on Transformer used.		2		mA
I <sub>ACT(COMC)</sub>		Daisy-chain interface communicating, capacitor isolation. There is a 10KΩ termination.		0.5		
I <sub>ACT(BAL)</sub>	Additional supply current during cell balancing	No communication. Cell balancing active.	125	145	170	μA
I <sub>ACT(CONVERT)</sub>	Additional supply current during ADC conversion	No communication, Only Conversion Conversion started, conversion period active;	2.05	2.42	2.65	mA
<b>Reference Voltages</b>						
V <sub>REF1</sub>	REF1 Reference voltage	REF1 capacitor = 1 μF, AVDD in regulation, T <sub>A</sub> = -40C to 105C	2.492	2.497	2.503	V
V <sub>REF1SWING</sub>	Detectable REF1 amplitude during oscillations (frequency from 0.2MHz to 10MHz)	Frequency between 0.2MHz to 10MHz.		330		mV
V <sub>REF1OV</sub>	Over-voltage threshold for REF1		2.52	2.59	2.66	V
V <sub>REF1UV</sub>	Undervoltage threshold for REF1		2.37	2.425	2.47	V
V <sub>REF2</sub>	REF2 reference voltage		1.0975	1.100	1.1025	V
V <sub>REF3</sub>	Internal bandgap voltage, used by POR circuits	-40C to 105C	1.2	1.22	1.26	V

## Electrical Characteristics (continued)

$V_{BAT} = 5.5V$  to  $30V$ , all LDOs operating in regulation, Typical Applications Circuit used, 3 to 6 cells connected,  $-40^{\circ}C$  to  $+105^{\circ}C$  free-air temperature range (unless otherwise noted)

PARAMETER		TEST CONDITIONS	MIN	TYP	MAX	UNIT
$V_{PTATGAIN}$	PTAT voltage gain	25C, AVDD_REF = 2.4V		1.17		mV/C
<b>Supplies</b>						
$V_{VLDO}$	VLDO output voltage	$I_{OUT} = 10\text{ mA}$ , $C = 1\ \mu\text{F}$	4.9	5.0	5.1	V
$V_{VLDOOV}$	VLDO Over-voltage threshold		5.31	5.6	5.87	V
$V_{VLDOOVHYS}$	VLDO OV hysteresis		50	60	150	mV
$I_{VLDO(LIMIT)LP}$	VLDO Current limit	External allowable load on the LDO including CVDD load, $C=2.2\mu\text{F}$ , SLEEP Mode.	7.9	14	23	mA
$I_{VLDO(LIMIT)HP}$	VLDO Current limit	External allowable load on the LDO including CVDD load, $C=2.2\mu\text{F}$ , Active Mode.	21.5	35	55	mA
$T_{SHUT(VLDO)R}$	VLDO LDO thermal shutdown threshold	TJ rising		138		$^{\circ}C$
$T_{SHUT(VLDO)F}$		TJ falling		123		$^{\circ}C$
$V_{TSREF}$	NTC monitor reference voltage		2.47	2.5	2.53	V
$I_{TSREF}$	TSREF current limit		5		12.6	mA
$V_{TSREFOV}$	TSREF over-voltage threshold	TSREF rising,	2.7		2.85	V
$V_{TSREFOVHYS}$	TSREF over-voltage threshold hysteresis	TSREF falling		160		mV
$V_{TSREFUV}$	TSREF under-voltage threshold	TSREF falling,	2.16	2.22	2.27	V
$V_{TSREFUVHYS}$	TSREF under-voltage threshold hysteresis	TSREF rising	65	80	95	mV
$V_{OSCTSREF}$	Detectable voltage oscillation above $V_{TSREF}$ at frequency from 0.2 MHz to 10 MHz			300		mV
$V_{AVDD}$	AVDD Output voltage	$I_{OUT} = 8\text{ mA}$ , $C = 2.2\ \mu\text{F}$	4.9	5.0	5.1	V
$V_{AVDDOV}$	AVDD over-voltage threshold	AVDD rising		5.7		V
$V_{AVDDOVHYS}$	AVDD OV hysteresis	AVDD falling		200		mV
$V_{AVDDUV\_F}$	Falling AVDD under-voltage threshold	AVDD Falling	4.10		4.25	V
$V_{AVDDUV\_R}$	Rising AVDD under-voltage threshold	AVDD Rising	4.4		4.65	V
$T_{SHUT(AVDD)R}$	AVDD LDO thermal shutdown threshold	TJ rising		138		$^{\circ}C$
$T_{SHUT(AVDD)F}$		TJ falling		123		$^{\circ}C$
$V_{DVDD}$	DVDD Output voltage	$I_{OUT} = 8\text{ mA}$ , $C = 2.2\ \mu\text{F}$	1.65	1.8	1.95	V
$V_{DVDDOV}$	DVDD over-voltage threshold	DVDD rising, 200mV hysteresis		2.2		V
$V_{DRDVDD\_F}$	Falling DVDD Digital Reset threshold	DVDD falling	1.57		1.66	V
$V_{DRDVDD\_R}$	Rising DVDD Digital Reset threshold	DVDD rising	1.67		1.77	V
$T_{SHUT(DVDD)R}$	DVDD LDO thermal shutdown threshold	TJ rising		138		$^{\circ}C$
$T_{SHUT(DVDD)F}$		TJ falling		123		$^{\circ}C$
$V_{AVAO\_REF\_1}$	Internal always-on supply rail (AVAO_REF)	$V_{bat} \geq 5.5V$	2.30	2.40	2.49	V
$V_{AVAO\_REF\_2}$		$4.75V < V_{bat} \leq 5.5V$ (Bridge devices)	2.24	2.4	2.48	V
$V_{AVAO\_REF\_UV}$	AVAO_REF under-voltage threshold	$V_{BAT}$ falling, 111mV hysteresis	1.93	1.98	2.18	V
$V_{AVAO\_REF\_OV}$	AVAO_REF over-voltage threshold	$V_{BAT}$ rising, 150mV hysteresis	2.75	2.85	2.95	V
$V_{AVAO\_REF\_OVHYS}$	AVAO_REF OV hysteresis	$V_{BAT}$ falling		130		mV
$V_{AVDDREF\_FLTZ}$	AVDD_REF UV threshold Falling	AVDD_REF falling, 100mV hysteresis		VAVAO-150mV		mV
$V_{AVDDREF\_FLTZ\_HYST}$	AVDD_REF UV hysteresis	AVDD_REF rising		50		mV
$V_{VPROG}$	OTP programming voltage input range		7.4	7.6	7.8	V
$V_{VPROGOV}$	VPROG overvoltage detection threshold	$V_{VPROG}$ rising,	7.85	7.91	8	V
$V_{VPROGUV}$	VPROG undervoltage detection threshold	$V_{VPROG}$ falling, 100mV hysteresis	7.2	7.25	7.35	V
$V_{VPROGUVHYS}$	VPROG undervoltage detection threshold hysteresis	$V_{VPROG}$ rising, $V_{AVDD} > 4.5V$ , $SH\_REFL = 1.1V$		85		mV

## Electrical Characteristics (continued)

$V_{BAT} = 5.5V$  to  $30V$ , all LDOs operating in regulation, Typical Applications Circuit used, 3 to 6 cells connected,  $-40^{\circ}C$  to  $+105^{\circ}C$  free-air temperature range (unless otherwise noted)

PARAMETER	TEST CONDITIONS	MIN	TYP	MAX	UNIT	
$V_{CVDD}$	CVDD voltage supply input range	4.9	5	5.1	V	
$V_{CVDDUV}$	CVDD under-voltage threshold	$V_{CVDD}$ falling, 100-mV hysteresis		4.56	V	
$V_{CVDDUVHYS}$	CVDD under-voltage threshold hysteresis		70		mV	
$V_{VIO}$	VIO voltage supply input range	1.8		5.25	V	
$V_{VIOUV\_Fall}$	VIO under-voltage threshold	VIO falling, 100-mV hysteresis		1.75	V	
$V_{VIOUV\_Hys}$	VIO under-voltage hysteresis threshold		0.1		V	
$V_{CVSSOPEN}$	CVSS open detection threshold	0.092		0.26	V	
$V_{DVSSOPEN}$	DVSS open detection threshold	0.092		0.26	V	
<b>CELL ADC Measurements (VC_Inputs)</b>						
$V_{C^*_N}$	Cell input voltage range	VCn to VCn-1, excluding VC1 to VC0, Common Mode Voltage >3V for VC3 to VC6.	-2		5.0	V
		VC1 to VC0	0		5.0	
$\Delta I_{VCn}$	VCn to VCn-1 input current mismatch	$(V_{CELLn} - V_{CELLn-1}) < 1V$ , $T_A = -20^{\circ}C$ to $+65^{\circ}C$			990	nA
$\Delta I_{VCn(FULL)}$		$-2V < V_{CELL} < 5V$ , $T_A = -40^{\circ}C$ to $+105^{\circ}C$			1.5	$\mu A$
$V_{ACC\_1}$	Total channel accuracy for voltage measurements	$V_{CELL} = 3V$ , CELL_ADC_CONF1[DR] = 0b11 $T_A = 25^{\circ}C$	-1.72		0.43	mV
$V_{ACC\_2}$	Total channel accuracy for voltage measurements	$2.0V < V_{CELL} < 5V$ , CELL_ADC_CONF1[DR] = 0b11 $T_A = 0^{\circ}C$ to $+65^{\circ}C$	-3.23		1.91	mV
$V_{ACC\_3}$	Total channel accuracy for voltage measurements	$2.0V < V_{CELL} < 5V$ , CELL_ADC_CONF1[DR] = 0b11 $T_A = -20^{\circ}C$ to $+65^{\circ}C$	-4.24		2.6	mV
$V_{ACC\_4}$	Total channel accuracy for voltage measurements	$2.0V < V_{CELL} < 5.0V$ , CELL_ADC_CONF1[DR] = 0b11 $T_A = -40^{\circ}C$ to $+105^{\circ}C$	-4.46		3.77	mV
$V_{ACC\_5}$	Total channel accuracy for voltage measurements	$-2.0V < V_{CELL} < 2.0V$ , CELL_ADC_CONF1[DR] = 0b11 $T_A = -20^{\circ}C$ to $+65^{\circ}C$	-14.32		14.07	mV
$V_{ACC\_Full}$	Total channel accuracy for voltage measurements	$-2V < V_{CELL} < 5V$ , CELL_ADC_CONF1[DR] = 0b11 $T_A = -40^{\circ}C$ to $+105^{\circ}C$	-18.22		15.56	mV
$V_{RES}$	Resolution for voltage measurements	256 decimation ratio selected		190.7		$\mu V$
$I_{VCOFF}$	VC* leakage currents	Cell measurements disabled			0.1	$\mu A$
$I_{VCONADC}$	VC* bias currents	Cell measurement active			3	$\mu A$
<b>Internal Temperature Sense</b>						
$T_{JADC\_RANGE}$	TINT range		-40		125	$^{\circ}C$
$T_{JADC\_RES1}$	TINT resolution	CELL_ADC_CONF1[DR] = 0b00		3.3		$^{\circ}C$
$T_{JADC\_RES2}$		CELL_ADC_CONF1[DR] = 0b11		0.125		$^{\circ}C$
$T_{JADC\_ACC}$	TINT temperature accuracy	CELL_ADC_CONF1[DR] = 0b11	-13		13	$^{\circ}C$
<b>AUX ADC Measurements</b>						
$V_{GPIO^*}$	Input voltage range GPIO* to AVSS		0.0		VIO	V
$V_{GPIORES2}$	GPIO_ measurement resolution	Absolute setting, DR=256.		190.7		$\mu V$
$V_{ACCGP(abs)}$	GPIO ADC measurement accuracy in absolute measurement mode	$1V < V_{GPIO} < 4.5V$ , $T_A = -40^{\circ}C$ to $+105^{\circ}C$ , DR=256.	-13.5		+13.5	mV
$V_{ACCGP(rat)}$	GPIO ADC measurement accuracy in ratiometric measurement mode	Percentage of TSREF, $T_A = -20^{\circ}C$ to $+65^{\circ}C$ , DR=256.	-1.22		1.19	%
		Percentage of TSREF, $T_A = -40^{\circ}C$ to $+105^{\circ}C$ , DR=256.	-1.28		1.23	
$V_{ACCBAT}$	Stack voltage measurement accuracy DR=256.	$V_{BAT} > 21V$	-300		+300	mV
$V_{ACCCELL}$	Cell voltage AUX ADC measurement accuracy DR=256.	$2V < V_{CB} < 5V$ , $T_A = -40^{\circ}C$ to $+105^{\circ}C$	-7.5		7.5	mV

## Electrical Characteristics (continued)

$V_{BAT} = 5.5V$  to  $30V$ , all LDOs operating in regulation, Typical Applications Circuit used, 3 to 6 cells connected,  $-40^{\circ}C$  to  $+105^{\circ}C$  free-air temperature range (unless otherwise noted)

PARAMETER		TEST CONDITIONS	MIN	TYP	MAX	UNIT
$V_{REF2\_AUX}$	Reference output measured by AUX, DR=256.		-17		10	mV
$V_{ZERO\_ACC\_AUX}$	Supply Rail ZERO ADC measurement accuracy, DR=256.		-25.02		18.2	mV
$V_{AVAO\_REF\_ACC\_AUX}$	Supply Rail AVAO_REF ADC measurement accuracy, DR=256.		-38		35	mV
$V_{REF3\_ACC\_AUX}$	Supply Rail REF3 ADC measurement accuracy, DR=256.		-21		13.2	mV
$V_{TSREF\_ACC\_AUX}$	Supply Rail TSREF ADC measurement accuracy, DR=256.		-50.5		38	mV
$V_{DVDD\_ACC\_AUX}$	Supply Rail DVDD ADC measurement accuracy, DR=256.		-21.5		15.1	mV
$V_{CVDD\_ACC\_AUX}$	Supply Rail CVDD ADC measurement accuracy, DR=256.		-139		106.5	mV
$V_{UT\_ACC\_AUX}$	UT DAC measurement accuracy, DR=256.		-39.05		24.91	mV
$V_{OT\_ACC\_AUX}$	OT DAC measurement accuracy, DR=256.		-32.6		32.4	mV
$V_{UV\_ACC\_AUX}$	UV DAC measurement accuracy, DR=256.		-53.2		79.6	mV
$V_{OV\_ACC\_AUX}$	OV DAC measurement accuracy, DR=256.		-76.4		114.85	mV
$V_{AVDD\_ACC\_AUX}$	Supply Rail AVDD ADC measurement accuracy, DR=256.		-57.15		44.06	mV
<b>Cell Balancing</b>						
$I_{BAL}$	Maximum balancing current with ambient temperature of 85 C	Per cell			150	mA
$R_{BAL}$	External Balancing current resistor range. The allowable range for the cell balancing resistor to set the balancing current upto 5mA to 150mA.		10		400	$\Omega$
$R_{DS(ON)}$	Balancing FET resistance	$V_{CELL} > 2V$	4.0	6.3	12	$\Omega$
$V_{CBDONE}$	CBDONE threshold range for cell balancing (measured at $VC_n$ to $VC_{n-1}$ )	$1 \leq n \leq 6$	2.8		4.3	V
$V_{CBDONEACC\_1}$	CBDONE threshold accuracy	-20C to 105C, $2.8V < V_{CELL} < 4.0V$	-45		45	mV
$V_{CBDONEACC\_1}$	CBDONE threshold accuracy	-20C to 105C, $4.0V < V_{CELL} < 4.3V$	-55		55	mV
$V_{BAL(MIN)}$	Minimum cell voltage for use of internal balancing FET		2			V
$I_{CBOFF}$	CB* leakage currents	CB disabled			0.1	$\mu A$
$V_{CBVCFLT}$	CBn pin fault threshold (faulted when $(CB_n - CB_{n-1}) / (VC_n - VC_{n-1}) > V_{CBVCFLT}$ )	$2V < V_{CELL} < 5V$ and $1 \leq n \leq 6$	67			%
$V_{VCLW}$	VCLW comparator threshold for proper CBVC comparator operation $VC_n - VC_{n-1} > V_{VCLW}$	$2V < V_{cell} < 5V$ and $1 \leq n \leq 6$		0.9		V
$I_{OWSNK}$	$VC_n$ and $CB_n$ OW sink current ( $VC$ and $CB = 3V$ )	$1 \leq n \leq 6$	170	250	350	$\mu A$
$I_{OWSRC}$	$VC_0$ and $CB_0$ OW source current ( $VC$ and $CB = 0V$ )	$n=0$	200	250	350	$\mu A$
$T_{SHUTC\_R}$	Cell Balancing TSHUT threshold rising		123	140	155	$^{\circ}C$
$T_{SHUTC\_F}$	Cell Balancing TSHUT threshold fallig			130		$^{\circ}C$
<b>Hardware Comparators</b>						
$V_{OV}$	OV comparator programmable range	$V_{CELL}$ rising, 100 mV Hysteresis, 25-mV LSB	2		5	V
$V_{OVHYS}$	OV comparator hysteresis	$V_{CELL}$ falling		100		mV
$V_{UV}$	UV comparator programmable range	$V_{CELL}$ falling, 100 mV Hysteresis, 25mV LSB	0.7		3.875	V

## Electrical Characteristics (continued)

$V_{BAT} = 5.5V$  to  $30V$ , all LDOs operating in regulation, Typical Applications Circuit used, 3 to 6 cells connected,  $-40^{\circ}C$  to  $+105^{\circ}C$  free-air temperature range (unless otherwise noted)

PARAMETER		TEST CONDITIONS	MIN	TYP	MAX	UNIT
$V_{UVHYS}$	UV comparator hysteresis	$V_{CELL}$ rising		100		mV
$V_{OT}$	OT comparator programmable range	$V_{GPIO}$ falling, 2% Hysteresis, 1% LSB	20		35	% of TSREF
$V_{OTHYS}$	OT comparator hysteresis	$V_{GPIO}$ rising		2		% of TSREF
$V_{UT}$	UT comparator programmable range	$V_{GPIO}$ rising, 2% Hysteresis, 1% LSB	60		75	% of TSREF
$V_{UTHYS}$	UT comparator hysteresis	$V_{GPIO}$ falling		2		% of TSREF
$V_{OVACC\_1}$	OV Comparator Accuracy	$T_A = -20^{\circ}C$ to $65^{\circ}C$ , $3.8V < V_{CELL} < 5V$	-28		25	mV
$V_{OVACC\_2}$	OV Comparator Accuracy	$T_A = -40^{\circ}C$ to $105^{\circ}C$ , $3.8V < V_{CELL} < 5V$	-43		37	mV
$V_{OVACC(FULL)}$		$T_A = -40^{\circ}C$ to $105^{\circ}C$ , $2V < V_{CELL} < 5V$	-75		56	mV
$V_{UVACC\_1}$	UV Comparator Accuracy	$T_A = -20^{\circ}C$ to $65^{\circ}C$ , $2.5V < V_{CELL} < 3.875V$	-60		40	mV
$V_{UVACC\_2}$	UV Comparator Accuracy	$T_A = -40^{\circ}C$ to $105^{\circ}C$ , $2.5V < V_{CELL} < 3.875V$	-70		50	mV
$V_{UVACC(FULL)}$		$T_A = -40^{\circ}C$ to $105^{\circ}C$ , $0.7V < V_{CELL} < 3.875V$	-100		67	mV
$I_{CBONCOMP}$	CB* bias currents	Hardware comparators enabled			6	$\mu A$
$V_{TSCMPACC}$	OT/UT Comparator Accuracy		-1		1	% of TSREF
<b>Daisy Chain Communication Bus</b>						
$R_{DCTX}$	Daisy chain transmitter output impedance			15		$\Omega$
$V_{DCCM}$	Daisy chain common mode voltage		2.3	2.45	2.6	V
$V_{COM\_Tone}$	Daisy-chain communication receiver threshold programmable range ( $V_{COM^*P} - V_{COM^*N}$ )	Communication tone Receiver threshold voltage (differential voltage). $V_{BAT} > 5.5V$ .	0.66		1.96	V
$V_{COM\_Data}$	Daisy-chain communication receiver threshold ( $V_{COM^*P} - V_{COM^*N}$ )	Communication Data Receiver threshold voltage (differential voltage). $V_{BAT} > 5.5V$ .	0.6		1.77	V
$V_{FAULTH\_Tone}$	Daisy-chain communication receiver threshold ( $V_{FAULTHP} - V_{FAULTHN}$ )	Fault Tone Receiver threshold voltage (differential voltage). $V_{BAT} > 5.5V$ .	0.22		1.77	V
<b>Digital I/Os (TX, RX, GPIO_, NFAULT, WAKEUP, SPI)</b>						
$V_{OH}$	Logic level output voltage high (TX, GPIO*, SDO)	GPIO configured as output, FET pull-up (Not Resistive) $I_{OUT} = 1\text{ mA}$ , $V_{VIO} = 3.3V$	$V_{IO} - 0.3$			V
$V_{OL}$	Logic level output voltage low (TX, NFAULT, GPIO*, SDO)	GPIO configured as output, FET pull-down (Not resistive) $I_{OUT} = 1\text{ mA}$ , $V_{VIO} = 3.3V$			0.3	V
$V_{IH}$	Logic level input voltage high (RX, GPIO*, WAKEUP, SDI)	GPIO configured as input. $V_{VIO} = 3.3V$	$0.65 \times V_{VIO}$			V
$V_{IL}$	Logic level input voltage low (RX, GPIO*, WAKEUP, SDI)	GPIO configured as input. $V_{VIO} = 3.3V$			$0.35 \times V_{VIO}$	V
$R_{PUWK}$	Weak pullup resistor	Weak pullup selected	120	200	310	k $\Omega$
$R_{PDWK}$	Weak pulldown resistor	Weak pulldown selected	120	200	310	k $\Omega$
$I_{LKG}$	Input leakage	Configured as analog input for ADC application			0.1	$\mu A$
<b>Thermal Protection</b>						
$T_{SD}$	Thermal shutdown threshold	$T_{DIE}$ rising, $V_{BAT} \geq 4.75V$	123	137	155	$^{\circ}C$
$T_{SD\_Fall}$	Thermal shutdown falling	$T_{DIE}$ falling, $V_{BAT} \geq 4.75V$	108		125.5	$^{\circ}C$
$T_{WARN}$	Temperature warning threshold (based on temperature ADC reading)	$T_{DIE}$ rising, $V_{BAT} \geq 4.75V$		115		$^{\circ}C$
$V_{PTAT}$	PTAT voltage at 25C	$T_A = 25^{\circ}C$		330		mV

## 7.6 Timing Requirements

$V_{BAT} = 5.5V$  to  $30V$ , all LDOs operating in regulation, Typical Applications Circuit used, 3 to 6 cells connected,  $-40^{\circ}C$  to  $+105^{\circ}C$  free-air temperature range (unless otherwise noted)

PARAMETERS	TEST CONDITIONS	MIN	NOM	MAX	UNIT
<b>State Change Timing</b>					

## Timing Requirements (continued)

$V_{BAT} = 5.5V$  to  $30V$ , all LDOs operating in regulation, Typical Applications Circuit used, 3 to 6 cells connected,  $-40^{\circ}C$  to  $+105^{\circ}C$  free-air temperature range (unless otherwise noted)

PARAMETERS		TEST CONDITIONS	MIN	NOM	MAX	UNIT
$t_{SU(WAKE)}$	SHUTDOWN to ACTIVE transition time with WAKEUP command	$V_{BAT} > 4.75V$ (CLDO=2.2uF) and in SHUTDOWN mode, WAKEUP command or WAKE tone received. For base: From the WAKEUP goes High to the first couplet of wakeup tone send out. For Stack: From last couplet of wakeup tone received to the first couplet of wakeup tone send out.			7	ms
$t_{SU(SLPtoACT)1}$	SLEEP to ACTIVE transition time with SLEEPToACTIVE command	$V_{BAT} > 4.75V$ , (CLDO=2.2uF). For base: From the RX pin goes high to the first couplet of Sleep to Active tone send out. For Stack: From last couplet of Sleep to Active tone received to the first couplet of sleep to active tone send out.			170	$\mu s$
$t_{SU(SLPtoACT)2}$	SLEEP to ACTIVE transition time with WAKEUP command	$V_{BAT} > 4.75V$ , (CLDO=2.2uF). For base: From the WAKEUP pin goes high to the first couplet of wake up tone send out. For Stack: From last couplet of wake up tone received to the first couplet of wake up tone send out.			500	$\mu s$
$t_{SDorSLP}$	Transition time to SLEEP or SHUTDOWN	$V_{BAT} > 4.75V$ , communication timeout short, SLEEP command received, Communication timeout long, SHUTDOWN command, shutdown pulse, or shutdown tone received (from the shutdown or sleep command received to 90% of REF1).			105	$\mu s$
$t_{PORtoWKRDY}$	Transition to SHUTDOWN from POR (initial power up time)	$V_{BAT} < POR$ to $V_{BAT} > POR$ , time to be ready for WAKE command- See start up diagram (BAT POR (4.75V) to VLDO>CVDDUV)		4		ms
$t_{RESET}$	Reset time during ACTIVE mode	WAKE tone, WAKEUP, or SOFT_RESET command received while in ACTIVE state. From the end of the tone or command or pulse to the time the first couplet send out.		500		$\mu s$
$t_{WKDLY(BS)}$	Delay after state transition to send WAKE or SLEEPToACTIVE tone for Base device or Bridge	$V_{BAT} > 4.75V$ , time to start of first tone pulse, with max capacitance and min LDO current limit		3.3		ms
$t_{WKDLY(SK)}$	Delay after state transition to send WAKE or SLEEPToACTIVE tone for stack device	$V_{BAT} > 4.75V$ , time to start of first tone pulse, with max capacitance and min LDO current limit		3.3		ms
$f_{REF1OSC}$	Detectable REF1 oscillation frequency	Amplitude $> V_{REF1SWING}$	0.2		10	MHz
$t_{REF1OSCFLT}$	Delay time from REF1 oscillation to fault indication			1.5		$\mu s$
<b>ADC Timings</b>						
$f_{ALIAS}$	Internal anti-alias filter corner frequency for CELL ADCs and AUX ADC (when doing AUX_CELL_SEL measurement)	-3 dB		1.5		kHz
$t_{DLY(COM)}$	Internal filter settling time after enabling the level shifters	Host must wait for this time after device enables the CELL level shifters before requesting an ADC conversion			5	ms
$t_{CONV32}$	ADC conversion time (CELL and AUX)	DR=32, time from ADCGO to data available	211	214	218	$\mu s$
$t_{CONV64}$	ADC conversion time (CELL and AUX)	DR=64, time from ADCGO to data available	306	311	316	$\mu s$
$t_{CONV128}$	ADC conversion time (CELL and AUX)	DR=128, time from ADCGO to data available	495	503	511	$\mu s$
$t_{CONV256}$	ADC conversion time (CELL and AUX)	DR=256, time from ADCGO to data available	873	887	901	$\mu s$
$t_{DELAY}$	Programmable delay from conversion command to start of conversion	Programmable range ADC_DELAY[DLY]. Total delay is $t_{DLY\_CELL} + t_{DELAY}$ or $t_{DLY\_AUX} + t_{DELAY}$	0		155	us
$t_{AUXDLY}$	Delay between measurements for auxiliary ADC	Allows for settling of the MUX when cycling through inputs			10.5	$\mu s$

## Timing Requirements (continued)

$V_{BAT} = 5.5V$  to  $30V$ , all LDOs operating in regulation, Typical Applications Circuit used, 3 to 6 cells connected,  $-40^{\circ}C$  to  $+105^{\circ}C$  free-air temperature range (unless otherwise noted)

PARAMETERS		TEST CONDITIONS	MIN	NOM	MAX	UNIT
<b>Cell Balancing</b>						
$t_{BAL}$	Balance timer accuracy		-10%		11.5%	
$t_{DEAD}$	Delay from switching from ODD to EVEN or EVEN to ODD			5		$\mu s$
$t_{CYCLE}$	Total CBDONE, OV/UV, and OT/UT round-robin monitoring cycle time	Cell balancing, OV/UV, or OT/UT enabled		17		ms
$t_{RR\_SLOT}$	Individual cell or GPIO monitoring time during the round-robin cycle	Cell balancing, OV/UV or OT/UT enabled		2		ms
$t_{dgOVUVCB}$	CBDONE, Over-voltage and under-voltage comparator programmable deglitch range.	Programmable in COMP_DG[OVUV_DG]	25		500	$\mu s$
$t_{dgACC}$	Accuracy on hardware comparator deglitch times		-10%		11.5%	
<b>Oscillator</b>						
$f_{HFO}$	High frequency oscillator frequency	$V_{BAT} > 4.5V$	31.52	32	32.48	MHz
$t_{HFOWD}$	High frequency oscillator (HFO) watchdog time	$V_{BAT} > 4.75V$ , sends device to RESET if oscillator stuck high or low for longer than this time	5		40	$\mu s$
$f_{LFO}$	Low frequency oscillator frequency		235.8	262	288.2	kHz
$t_{LFOWD}$	Low frequency oscillator (LFO) watchdog time	$V_{BAT} > 4.75V$ , flags error if oscillator is stuck high or low for longer than this time		35		$\mu s$
<b>Digital I/Os (TX, RX, GPIO_, NFAULT, WAKEUP)</b>						
$t_{OUTRISE}$	Rise time (TX, GPIO*)	$V_{VIO}=4.8V$ , $C_{LOAD}=150pF$ , GPIO in output mode		12		ns
$t_{OUTFALL}$	Fall time (TX, GPIO*)	$V_{VIO}=4.8V$ , $C_{LOAD}=150pF$ , GPIO in output mode		12		ns
$t_{FALLNFLT}$	Fall time (NFAULT)	$V_{VIO}=4.8V$ , $R_{PULLUP} = 10k\Omega$ , $C_{LOAD}=150pF$		35		ns
$t_{dg\_GPIO}$	Deglitch for GPIO for fault indication	fault enabled		45		$\mu s$
$t_{HLD\_WAKE}$	WAKEUP input hold time for WAKE command (low-pulse width) (max value guaranties a wake up of the device and below min should guarantiy no wake up)	$V_{BAT} \geq 4.75V$	250		300	$\mu s$
$t_{HLD\_SD}$	WAKEUP input hold time for SHUTDOWN command (low-pulse width) (max value guaranties a shutdown of the device and below the min should guaranties no shutdown)	$V_{BAT} \geq 4.75V$	1400		1600	$\mu s$
<b>SPI Master Interface</b>						
$f_{SCLK}$	SCLK frequency		450	500	550	kHz
$t_{HIGH:LOW}$	SCLK duty cycle		40	50	60	%
$t_{SS,HI}$	SS hi latency time. Time from register write high to SS high			1		$\mu s$
$t_{SS,LOW}$	SS low latency time. Time from register write low to SS low			1		$\mu s$
$t_{SU,MISO}$	MISO input data setup time	MISO stable before SCLK transition	100			ns
$t_{HD,MISO}$	MISO input data hold time	MISO stable after SCLK transition		0		ns
$t_{VALID, MOSI}$	MOSI output data valid time	MOSI stable after SCLK transition		10	20	ns
$t_{MOSI,DIS}$	SS disable time to MOSI high impedance (tri-state)			20	50	ns
$t_{dg\_GPIO}$	Deglitch for GPIO for fault indication	GPIO*_CONF[FAULT_EN]#0b00		25		$\mu s$
<b>Daisy-Chain Communication Interface</b>						
$t_{PW\_DC}$	Pulse width of data (half bit time) for communication	$V_{BAT} > 4.75V$	230	250	270	ns
$t_{RECLK\_DC}$	Data re-clocking delay per device (COMH to COML or vice versa depending on communication direction)	$V_{BAT} > 4.75V$ , ACTIVE mode		3		$\mu s$
$n_{WAKEDET}$	WAKE tone receive threshold	$V_{BAT} > 4.75V$		20		pulses



## Timing Requirements (continued)

$V_{BAT} = 5.5V$  to  $30V$ , all LDOs operating in regulation, Typical Applications Circuit used, 3 to 6 cells connected,  $-40^{\circ}C$  to  $+105^{\circ}C$  free-air temperature range (unless otherwise noted)

PARAMETERS		TEST CONDITIONS	MIN	NOM	MAX	UNIT
$n_{WAKE}$	WAKE tone sending duration	$V_{BAT} > 4.75V$		40		pulses
$n_{SLPtoACTDET}$	SLEEPtoACTIVE tone receive threshold	$V_{BAT} > 4.75V$		20		pulses
$n_{SLPtoACT}$	SLEEPtoACTIVE tone sending duration	$V_{BAT} > 4.75V$		40		pulses
$n_{SHDNDET}$	SHUTDOWN tone receive threshold	$V_{BAT} > 4.75V$		100		pulses
$n_{SHDN}$	SHUTDOWN tone sending duration	$V_{BAT} > 4.75V$		185		pulses
$n_{FLTTONEDET}$	Fault tone detection threshold	$V_{BAT} > 4.75V$ , fault condition present		20		pulses
$n_{FLTONE}$	Fault tone sending duration	$V_{BAT} > 4.75V$ , fault condition present		40		pulses
$t_{FLTRETRY}$	Fault tone retry during persistent fault condition	$V_{BAT} > 4.75V$ , fault condition present		50		ms
$n_{FLTHBDET}$	Heartbeat tone detection threshold	$V_{BAT} > 4.75V$ , no fault present, heartbeat enabled		20		pulses
$n_{HBTONE}$	Heartbeat tone sending duration	$V_{BAT} > 4.75V$ , no fault present, heartbeat enabled		40		pulses
$t_{WAITHB}$	Time between heartbeat tones	$V_{BAT} > 4.75V$ , no fault present, heartbeat enabled		400		ms
$t_{HBTO}$	Heartbeat fault timeout	$V_{BAT} > 4.75V$ , fault signaled if no heartbeat received with $t_{HBTO}$		1		s
$t_{HBFAS}$	Heartbeat received to fast threshold	$V_{BAT} > 4.75V$ , fault signaled if the time between heartbeat tones is less than $t_{HBFAS}$		200		ms
$t_{FLTONE\_HI}$	Fault pulse high time (analog delay based)			1		$\mu s$
$t_{FLTONE\_LO}$	Fault pulse low time			1		$\mu s$
$t_{FLTONE}$	Time between pulses within a fault tone (LFO based). From the beginning of a pulse until the beginning of the next pulse.			11.5		$\mu s$
$t_{COMTONE}$	Time between pulses within a comms tone (HFO based). From the beginning of a pulse until the beginning of the next pulse.			11		$\mu s$
$t_{TONE\_HI}$	Comms pulse high time (HFO based)			1		$\mu s$
$t_{TONE\_LO}$	Comms pulse low time (HFO based)			1		$\mu s$
$t_{FTS\_Latency}$	Fault Tone Latency in stack device	Latency from fault tone received/detected to fault tone going out in a stack device.		48		$\mu s$
$t_{FTB\_Latency}$	Fault Tone Latency in base device	Latency from fault tone received/detected in base device to NFAULT tone going out.		24		$\mu s$
<b>UART Interface</b>						
$RXTX_{BAUD}$	RX/TX signaling rate adjustable range	$V_{BAT} > 4.75V$	125		1000	kbps
$ERR_{BD(RX)}$	Input baud rate error	$V_{BAT} > 4.75V$	-1.5%		1.5%	
$ERR_{BD(TX)}$	Output baud rate error	$V_{BAT} > 4.75V$	-1.5%		1.5%	
$t_{UART(BRK)}$	Communications clear (break) time	$V_{BAT} > 4.75V$	15		20	bit periods
$t_{UART(SIA)}$	SLEEPtoACTIVE time	$V_{BAT} > 4.75V$ , RX held low	250		300	$\mu s$
$t_{UART(RST)}$	Communications reset time	$V_{BAT} > 4.75V$ , RX held low	450			$\mu s$
$t_{UART(RXMIN)}$	Minimum RX high time after Communications Clear received		1			bit periods
<b>Safety Diagnostics</b>						
$t_{VIOUVDGL}$	Under-voltage deglitch on VIO	$V_{VIO}$ rising. $V_{VIO} < V_{VIOUV}$ threshold to corresponding flag set		25		$\mu s$
$t_{OVDGL}$	Over-voltage deglitch on supply rails (AVDD, DVDD)	$V_{SUPPLY}$ rising. $V_{SUPPLY} > V_{OV}$ threshold to corresponding flag set		25		$\mu s$
$t_{OVCVDDGL}$	Over-voltage deglitch on VLDO supply rail	$V_{VLDO}$ rising. $V_{VLDO} > V_{OV}$ threshold to corresponding flag set		250		$\mu s$
$t_{UVVGL}$	Under-voltage deglitch on supply rails (AVDD, CVDD)	$V_{SUPPLY}$ falling. $V_{SUPPLY} < V_{UV}$ threshold to corresponding flag set		25		$\mu s$



## Timing Requirements (continued)

$V_{BAT} = 5.5V$  to  $30V$ , all LDOs operating in regulation, Typical Applications Circuit used, 3 to 6 cells connected,  $-40^{\circ}C$  to  $+105^{\circ}C$  free-air temperature range (unless otherwise noted)

PARAMETERS	TEST CONDITIONS	MIN	NOM	MAX	UNIT
$t_{DVDDPORDGL}$	POR deglitch for DVDD supply	$V_{DVDD}$ falling. $V_{DVDD} < V_{DVDDPOR}$ threshold to device power down	25		$\mu s$
$t_{TSREFBLNK}$	TSREF startup blanking time (TSREF OV/UV and the OTUT function ignored)	TSREF startup	2		ms
$t_{TSREFDG}$	TSREF OV/UV deglitch time setting	After $t_{TSREFBLK}$ expires, $V_{TSREF}$ rising or falling.	25		$\mu s$
$t_{BISTDG}$	Deglitch for BIST for hardware comparators	BIST enabled for OVUV and/or OTUT	25		$\mu s$
$t_{AVDDREFUV DGL}$	Deglitch on internal AVDD_REF under-voltage		25		$\mu s$
$t_{AVAODGL}$	Deglitch on internal AVAO_REF protections (OV, UV, SW)		25		$\mu s$
$t_{CBVCDGL}$	Deglitch on CBVC comparators		25		$\mu s$
$t_{VCLWDGL}$	Deglitch on VLOW comparators		25		$\mu s$
$t_{TSHUTDGL}$	Thermal shutdown comparator deglitch	Temperature rising. $T_J > T_{SHUT}$ to device shut down	25		$\mu s$
$t_{VSS\_OPEN}$	Open VSS fault deglitch time (CVSS_OPEN, DVSS_OPEN)		25		$\mu s$
$t_{RAIL\_OSC}$	Rail oscillation fault deglitch time (AVDD_OSC, TSREF_OSC, REF1_OSC)		25		$\mu s$
$f_{LFO\_CHECK}$	LFO frequency checker	Sets SYS_FAULT3[LFO_FLT] when LFO frequency is outside of this range	196.5	327.5	kHz
$t_{CRC\_COM}$	Communication CRC validation time	$V_{BAT} > 4.75V$		2	$\mu s$
$t_{CRC\_OTP}$	Period for auto CRC updates on NVM	$V_{BAT} > 4.75V$		2	ms
$t_{OVUV\_BIST}$	BIST time for OVUV and CBDONE round-robin	BIST enabled, uses LFO, measured from reset expired	4.5		ms
$t_{OTUT\_BIST}$	BIST time for OTUT round-robin	BIST enabled, uses LFO, measured from reset expired	2.4		ms
$t_{BISTDG}$	Deglitch on checks during OVUV, CBDONE, and OTUT BIST	BIST enabled	25		$\mu s$

## 7.7 Typical Characteristics

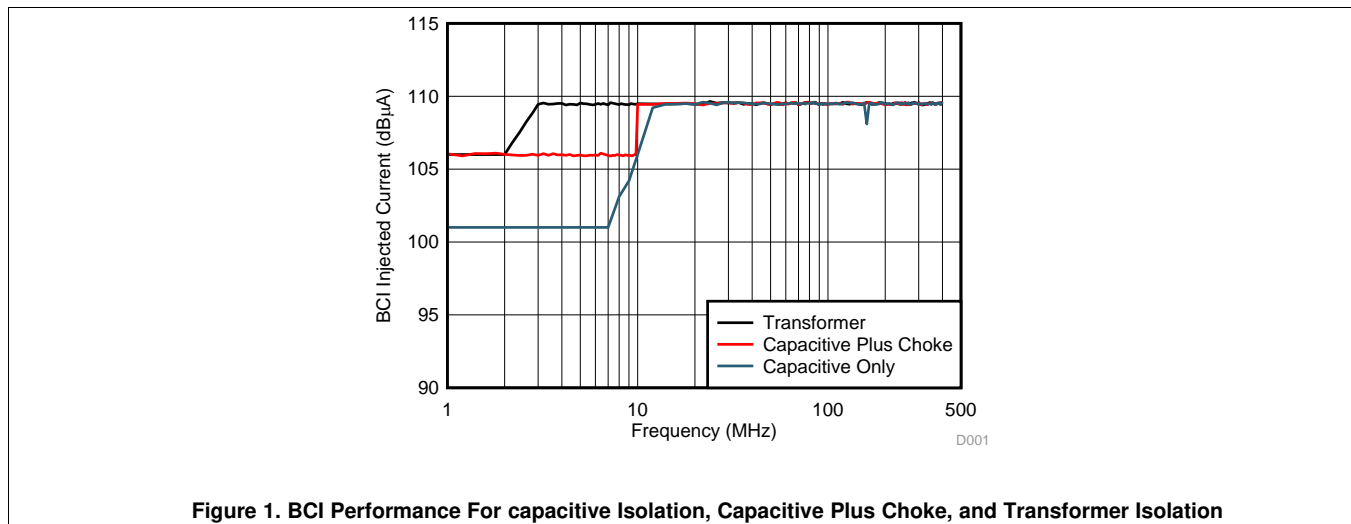

## 8 Detailed Description

### 8.1 Overview

The BQ79606A-Q1 is a voltage monitoring device for large battery stack systems. The device has the ability to measure single cell voltages as well as the voltage across any connector used to create larger battery stacks in a module. The BQ79606A-Q1 is designed with low voltage differential daisy chain communication, allowing for the connection of up to 64 (1 base and 63 stack) BQ79606A-Q1 devices. The combination of devices allows for easy combination of batteries to achieve the desired voltage of the system.

---

#### NOTE

Throughout the document, '\*' are used as wild cards (typically to indicate numbers such as CELL\* means CELL1-CELL6. Additionally, bits are referred to in the following convention REGNAME[BITNAME].

---

---

#### NOTE

Throughout the document, Bridge, Base, and Stack devices terminology are used. Bridge is used for devices connecting the uC with stack devices through UART and DO NOT monitor cell voltages. Base is used for devices connecting the uC with the stack devices through UART and monitors cell voltages at the same time. Stack devices monitors the cell but do not communication directly with uC through UART.

---

## 8.2 Functional Block Diagram

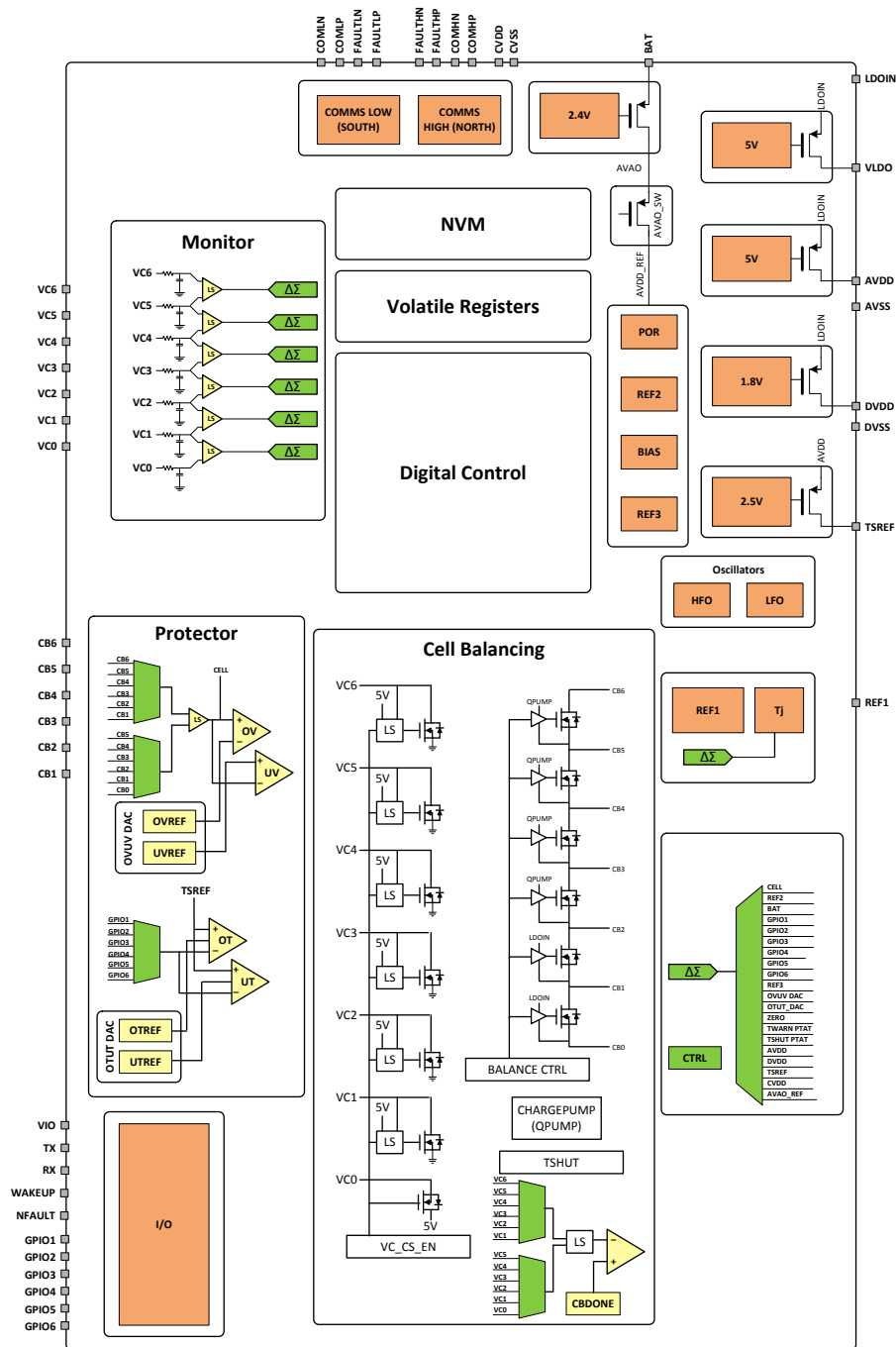

## 8.3 Feature Description

This section includes the descriptions of the individual blocks found in the BQ79606A-Q1 device.

### 8.3.1 Power Supplies

The BQ79606A-Q1 generates all of the required supplies for operation. There are 3 integrated LDO supplies as well as a buffered reference to supply the bias for the GPIO\* NTC monitoring linearization circuits (for temperature sensing).

#### 8.3.1.1 AVDD LDO

The AVDD low dropout regulator (LDO) is the supply for the analog circuits in the BQ79606A-Q1. The supply for AVDD comes from LDOIN. AVDD contains an over-voltage comparator that signals a fault (RAIL\_FAULT[AVDDOV]) when the voltage at AVDD rises above  $V_{AVDDOV}$ . Additionally, AVDD contains an under-voltage circuit that sends the IC into Digital Reset when AVDD drops below  $V_{AVDDUV}$ . Upon restarting, a fault is indicated (RAIL\_FAULT[AVDDUV\_DRST]) to inform the host why the IC failed. Additionally, AVDD is continuously monitored for abnormal oscillations that can result in undesired operation. If such an oscillation occurs, the SYS\_FAULT2[AVDD\_OSC] bit is set.

#### 8.3.1.2 VLDO LDO

The VLDO low dropout regulator (LDO) is the supply for the daisy chain transceiver circuits in the BQ79606A-Q1. The supply for VLDO comes from LDOIN. VLDO contains an overvoltage comparator that signals a fault (RAIL\_FAULT[VLDOOV]) when the voltage at VLDO rises above  $V_{VLDOOV}$ .

#### 8.3.1.3 DVDD LDO

The DVDD low dropout regulator (LDO) is the supply for the digital circuits in the BQ79606A-Q1. The supply for DVDD comes from LDOIN. DVDD contains an overvoltage comparator that signals a fault (RAIL\_FAULT[DVDDOV]) when the voltage at DVDD rises above  $V_{DVDDOV}$ . Additionally, DVDD contains a comparator that sets digital in reset mode if DVDD drops below  $V_{DRDVDD}$ . Additionally, the DVSS pin is monitored continuously and the SYS\_FAULT2[DVSS\_OPEN] bit is set if an 'open' condition is detected for DVSS.

#### 8.3.1.4 TSREF

The TSREF is a 2.5V buffered REF1 reference that supplies the GPIO\* linearization circuits when measuring external temperature sensors. This allows the ADC to operate from the same reference and provide a ratiometric result for GPIO\*. TSREF is capable of supplying up to  $I_{TSREF}$  current limit and must not be used to power any circuits other than the resistor dividers for GPIO\*. Enable TSREF using the CONTROL2[TSREF\_EN] bit. The startup time for TSREF is determined by the external capacitance and the current limit. The time is calculated using the simple capacitor charging equation. No GPIO measurements should be taken until TSREF is settled at the regulation point.

See [Ratiometric Measurement Configuration](#) for details on selecting the resistors. TSREF contains an over-voltage comparator that signals a fault (RAIL\_FAULT[TSREFOV]) when the voltage at TSREF rises above  $V_{TSREFOV}$ . Additionally, TSREF contains an under-voltage circuit that signals a fault (RAIL\_FAULT[TSREFUV]) when TSREF drops below  $V_{TSREFUV}$ . Additionally, TSREF is continuously monitored for abnormal oscillations that can result in undersired operation. If such an oscillation occurs, the SYS\_FAULT2[TSREF\_OSC] bit is set.

#### 8.3.1.5 Internal Supply Rails

AVAO\_REF (Analog Voltage Always On) is a fully internal rail that runs from the BAT input. It powers low current circuits that are required in all modes. AVAO\_REF is continuously monitored for over and under voltage conditions. The overvoltage comparator signals a fault (SYS\_FAULT1[AVAO\_REF\_OV]) when the voltage at AVAO\_REF rises above  $V_{AVAO\_REF\_OV}$ . Additionally, AVAO\_REF contains an under-voltage circuit that puts the IC into POR mode if  $V_{AVAO\_REF}$  drops below  $V_{AVAO\_REF\_UV}$ .

#### 8.3.1.6 CVDD and VIO Supplies

CVDD is the supply input for the daisy chain transceiver circuits. CVDD receives it's power externally from VLDO. This allows for external filtering for noisy applications. CVDD is monitored for under-voltage constantly. If  $V_{CVDD} < V_{CVDDUV}$  the RAIL\_FAULT[CVDDUV] bit is set. Additionally, the CVSS pin is monitored continuously, and the SYS\_FAULT2[CVSS\_OPEN] bit is set if an 'open' condition is detected for CVSS.

### Feature Description (continued)

VIO is the supply for digital inputs. The RX, WAKEUP (for base) and NFAULT (if used) pins are all referenced to VIO (TX must be pulled high at host side). VIO is supplied from the system logic supply, or is connected to VLDO or CVDD for stack devices (for systems without a logic supply). VIO is monitored for under-voltage constantly. If  $V_{VIO} < V_{VIOUV}$  the SYS\_FAULT3[VIOUV] bit is set. Do not toggle VIO in shut down mode, otherwise a device could exit shutdown mode.

#### 8.3.1.7 Startup

The LDOs are on in the different modes as described in *Device Functional Modes*. Upon power up, the startup is shown in Figure 2.

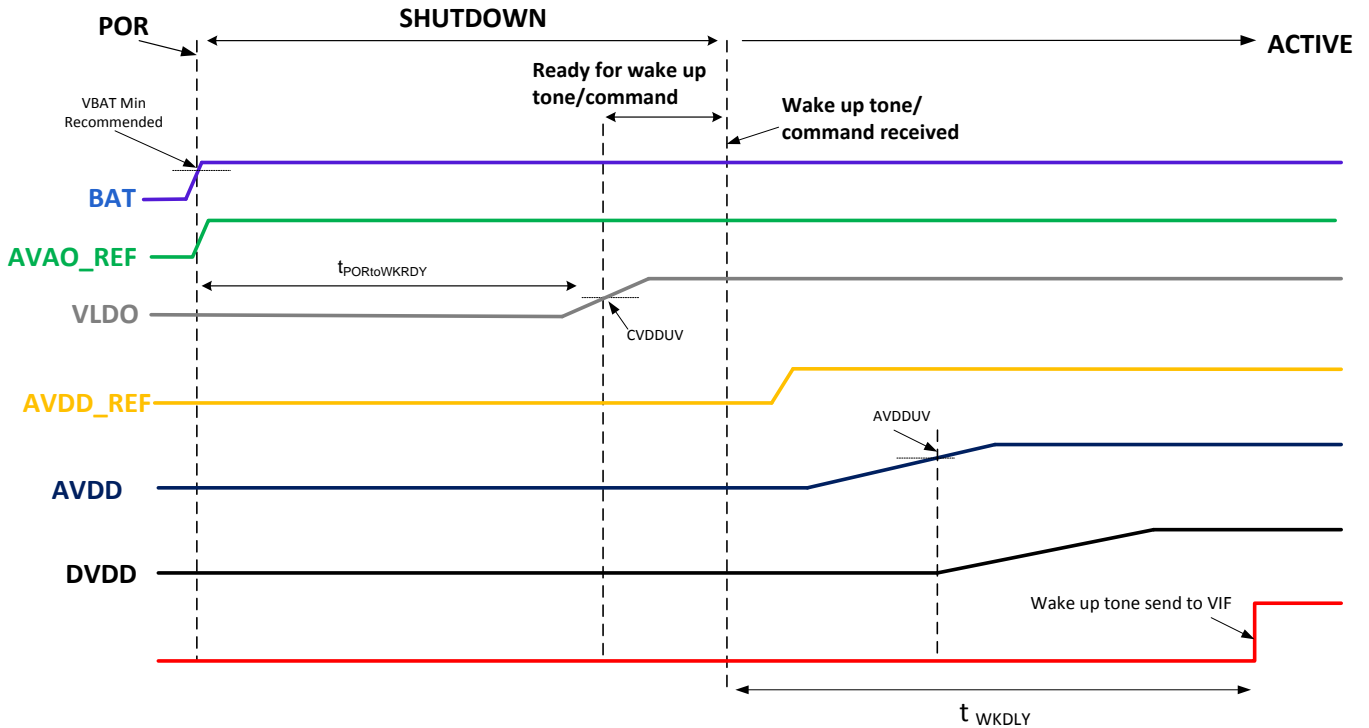
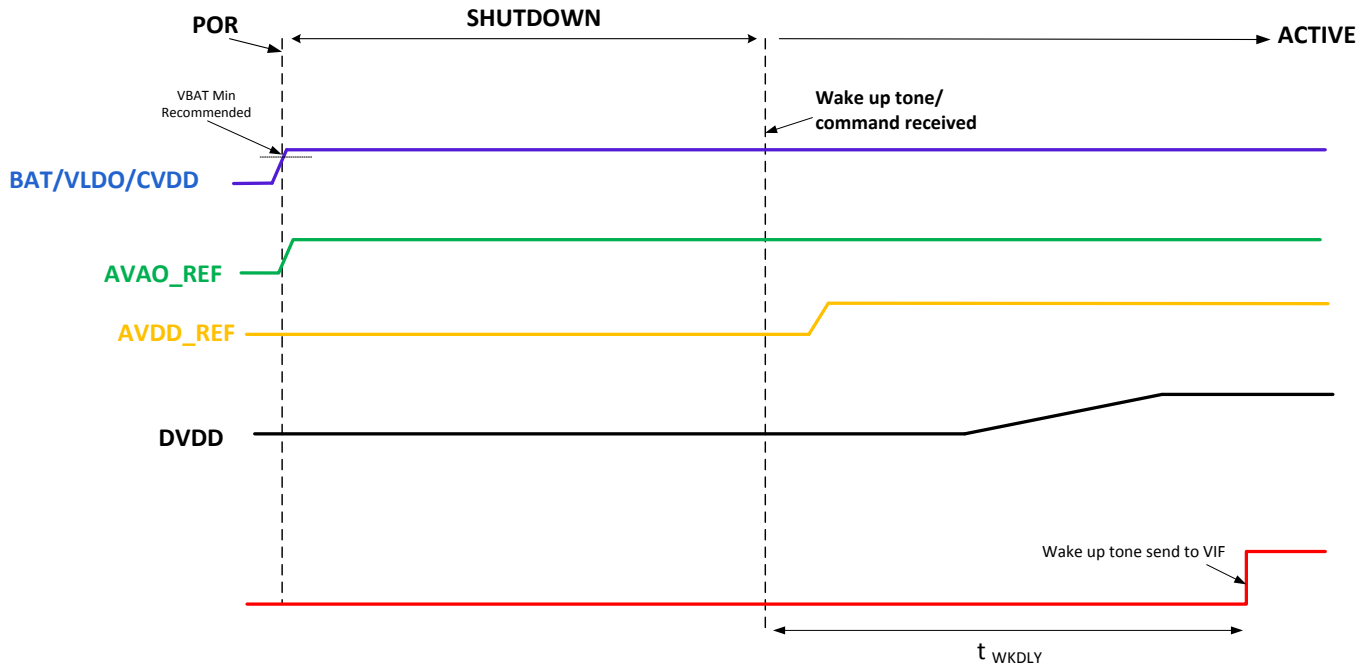

Figure 2. Startup Diagram

**Feature Description (continued)**

**Figure 3. Startup Diagram (Bridge Configuration)**

After power up and the wake up (tone or command) is sent, the following steps are required to sync the DLL (Delay-Locked Loop) ramp in both direction:

1. Broadcast write command to write "0x00" hex value to ECC\_TEST register
2. Perform auto addressing by sending a broadcast command to set CONTROL1[ADD\_WRITE\_EN]=1 (to enable addressing)
3. Broadcast write consecutive addresses to DEVADD\_USR[ADD] until all parts have been assigned a valid address
4. Set the Base by writing 0 to CONFIG[STACK\_DEV] of the first device
5. Set the Stack by writing 1 to CONFIG[STACK\_DEV] of the other device (other than first and last)
6. Set Top of Stack to the top device by writing 1 to CONFIG[TOP\_STACK] of the top device
7. Broadcast dummy read attempts such as reading register ECC\_TEST (host may not get the data)
8. Clear the faults if DLL causes any COMH and COML errors.

**NOTE**

The host must wait for the device to fully wake up (  $t_{SU(WAKE)}$  ) before sending shutdown, sleep, wake up commands.

**8.3.2 Precision References**

REF1 and REF2 are precision references used by the BQ79606A-Q1 to achieve high performance. REF1 is used for the ADC functions as well as providing the TSREF reference. REF2 is used for the protector functionality and used to check accuracy and diagnostics. REF1 is active whenever the BQ79606A-Q1 is in ACTIVE mode and REF2 is active in both SLEEP and ACTIVE. The REF1 reference is not active in SLEEP mode however the REF1 pin is powered from the AVDD through an internal voltage divider.

An oscillation detector monitors REF1 and sets the SYS\_FAULT2[REF1\_OSC] bit whenever it senses a REF1 oscillation. To avoid false trips during startup, the oscillation detection is disabled for the first 10ms of REF1 startup (IC transitions into ACTIVE state).

## Feature Description (continued)

### NOTE

Contact TI Sales Associate or Applications Engineer for further information about long term drift.

### 8.3.3 Analog Front End

The BQ79606A-Q1 AFE allows monitoring of up to 6 cells. The interface to these cells is provided using seven VC inputs, labeled VC0 through VC6. The cell monitoring is programmable for on-demand or continuous sampling of all, or a subset, of the connected cells. When multiple cell conversions are selected, either on-demand or continuous, the cell voltages are read simultaneously to provide a snapshot of the stack voltage at a particular point in time. This allows for measurements to be synchronized with current readings and enable a more accurate gauging solution.

Nearly all of the components required for analog front end filtering and surviving hot-plug testing are integrated into the BQ79606A-Q1. Additionally, for hot-plug requirements, the device can handle high voltage spikes of up to +/-33 V, therefore no Zener and regular diode clamps are required for voltage spikes below that level. For voltage spikes that may be higher than the absolute maximum rating of the device, additional clamping is required. An external RC filter on VC\* and CB\* is required to filter out high frequency voltage spike and hot-plug events. The pins are internally clamped to facilitate the use of the inexpensive, low voltage (10V) ceramic capacitors. See [VC\\* Inputs](#) for more details on selecting these components.

#### 8.3.3.1 VC Current Sinks and Sources

The VC\_CS\_CTRL register allows the host to enable current sinks (VC1-VC6) or current source (VC0) to attempt to pull the pin up/down to diagnose a VC open-wire condition. There are no internal comparisons done on the pins, it is up to the host to diagnose an open-wire condition using the ADC's. The current sources/sinks are limited to I<sub>OWSNK</sub> and I<sub>OWSRC</sub>, therefore special attention must be paid to the size of the external components and the time it takes to discharge any external capacitance.

### 8.3.4 Delta-Sigma ( $\Delta\Sigma$ ) Converters

The BQ79606A-Q1 integrates 8, high accuracy Delta-Sigma ADCs for measuring the cell and other voltages in the system. The cell voltages are monitored using 6 independent ADCs to enable simultaneous measurements. An additional ADC is integrated to measure external NTCs or voltages as well as other internal rails. The DIE temperature is monitored using a dedicated ADC. Each sense input, VC0 to VC6, is intended to connect to the single cell of a battery stack or the module connector of a sub-stack in the system. Each block contains a Delta-Sigma analog to digital converter (ADC) that samples and converts the voltage present between the pins VCn and VCn-1 during a sample.

- Cell Voltage ADC - one ADC per Channel
- DIE Temperature ADC
- Auxiliary ADC
  - Cell Voltage (selected by AUX\_CELL\_SEL bits)
  - Total Stack Voltage (BAT voltage)
  - REF2
  - ZERO (0V) Reference
  - AVDD LDO
  - GPIO1-GPIO6
  - REF3
  - OV DAC
  - UV DAC
  - OT DAC
  - UT DAC
  - VPTAT
  - DVDD LDO

**Feature Description (continued)**

- TSREF LDO
- CVDD
- AVAO\_REF

**8.3.4.1 ADC Architecture**

The entire signal chain, as seen in Figure 4, consists of an internal input filter, a modulator, a SINC<sup>3</sup> filter, and a digital low pass filter; each of these is described in more detail below.

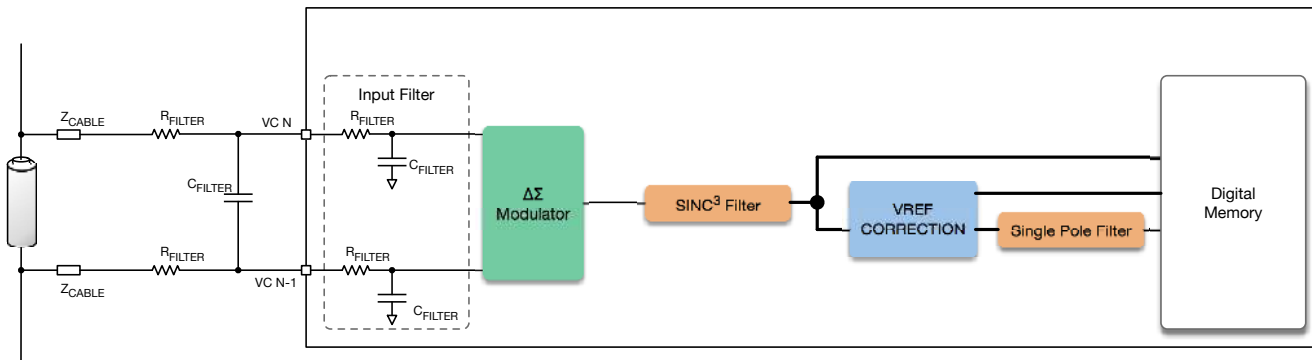

**Figure 4. Battery Voltage Signal Chain**

**8.3.4.1.1 Internal Input Filter**

The purpose of the internal input filter is to limit the bandwidth seen by the modulator to ensure aliasing effects seen at multiples of the modulator's sample frequency are significantly reduced. The corner frequency of this internal input filter is 1.5kHz, significantly below the sample frequency of the modulator to avoid aliasing effects.

**8.3.4.1.2 Modulator**

The modulator has a functional block diagram as shown in Figure 5. The Delta Sigma used is a second order modulator and consists of a difference amplifier, the "Delta," and an integrator, the "Sigma," followed by a second difference amplifier and integrator. The output of the second integrator is the input to a comparator that produces a pulse train with the density of pulses proportional to the voltage at the input. This pulse train is converted back to a voltage through the 1-bit DAC to be fed into the Delta stages.

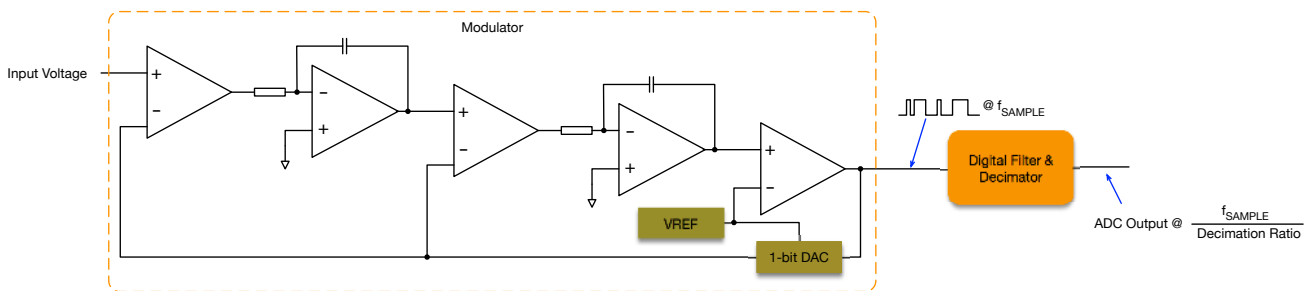

**Figure 5. Simplified Modulator Block Diagram**



## Feature Description (continued)

### 8.3.4.1.3 SINC<sup>3</sup> Digital Filter (CIC)

The digital filter used in the BQ79606A-Q1 is a Cascaded Integrating Comb (CIC) filter, often referred to as a SINC<sup>x</sup> filter, where the "x" represents the order of the filter. The simplified block diagram of the filter is shown in Figure 6. The BQ79606A-Q1 contains a 3rd order CIC filter, meaning there are three storage elements on both sides of the decimation switch. The Decimation Ratio, or DR, references to the rate of reduction applied to the sample clock of the modulator. The front half of any SINC<sup>3</sup> filter, which integrates the modulator output, is run at the same clock rate as the modulator. The back half of the SINC<sup>3</sup> filter, which generates the comb, runs at the decimated clock rate, as shown.

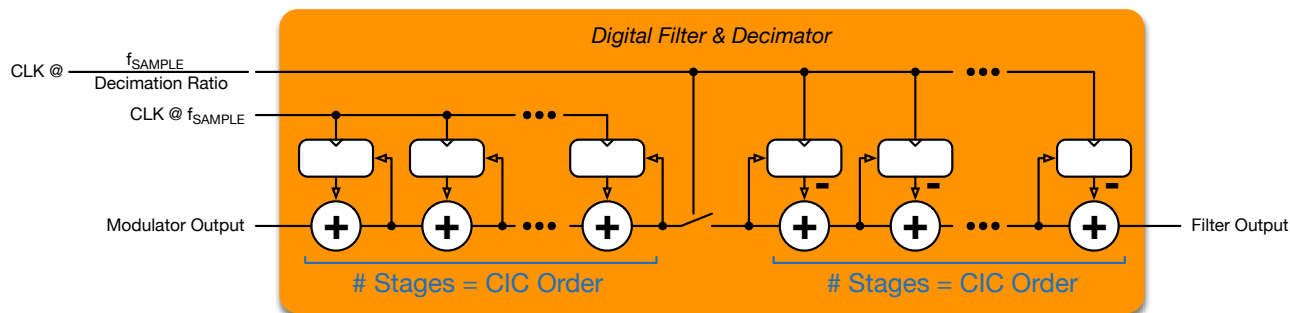

Figure 6. Simplified CIC Digital Filter Block Diagram

The SINC<sup>3</sup> filter will result in the frequency response. Note that the decimation ratio, DR, impacts the width of the passband; the higher DR the lower the corner frequency of the filter. The order of the filter also sets the gain, as  $G = -20^{\text{ORDER}}$  dB/Decade.

#### NOTE

Decimation Ratio is also called Over-Sampling Rate, or OSR, in other descriptions of a SINC<sup>x</sup> filter. The SINC<sup>x</sup> filter name is historic, as the transfer response, which is beyond the scope of this document to derive, is similar to the classic definition of  $\text{sinc}(x)$ , or  $\sin(x)/x$ .

#### 8.3.4.1.3.1 Example Frequency Response of a Delta-Sigma Converter

The decimation ratio (DR) directly correlates to how quickly a conversion result is available to be read from the ADC. Lower DR corresponds to faster conversion time and lower effective number of bits (ENOB).

The reference voltage used in the modulator has an internal correction that is applied automatically. This correction is shown in Figure 4 as occurring immediately after the SINC<sup>3</sup> filter. This correction becomes overhead to the conversion time. The uncorrected value is also made available for host access in the event that external correction is required to account for reference voltage shifts. See Register: VC3COEFF5 for details about the conversion times and ENOB at different DRs.

The decimation ratio is configured using the CELL\_ADC\_CONF1[DR] (for the cell ADCs) and AUX\_ADC\_CONF[DR] (for the AUX ADC). The temperature ADC settings match the CELL ADC settings.

Table 1. Decimation Rate and Conversion Times (CELL ADC and AUX ADC)

ADCCONF0[DR]	Decimation Ratio	ADC Conversion Time (Typical) [μs]	ENOB
0b00	32	214	9
0b01	64	311	11
0b10	128	503	13
0b11	256	887	16

### 8.3.4.1.4 Single Pole Digital Filter

In addition to the SINC<sup>3</sup> filter, a digital implementation of a simple, first-order, single pole (RC) filter is also included. The implementation is shown in Figure 7. This filter allows for much lower corner frequencies for the digital filter and the implementation does not require a fixed point multiplication stage. This filter always uses the corrected VREF value coming from the SINC<sup>3</sup> filter. When enabled, the cell ADCs are run in continuous mode with the minimum interval setting, updating the uncorrected non filtered (VCELL\*\_HU, VCELL\*\_MU, and VCELL\*\_LU), the corrected non filtered (VCELL\*H and VCELL\*L), and the corrected and filtered (VCELL\*\_LF and VCELL\*\_HF) registers every time the host reads High byte (H).

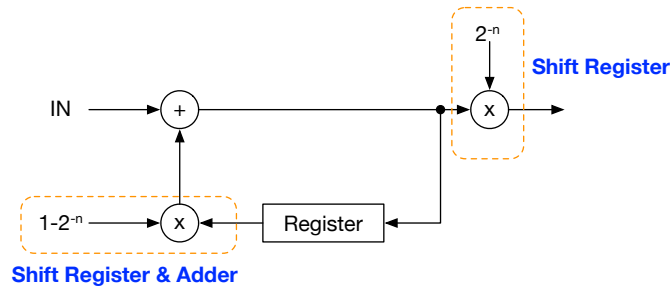

Figure 7. Single Pole Digital Filter Implementation

The corner frequency of the single pole digital filter is set with the CELL\_ADC\_CONF1[FILSHIFT] bits, as shown in Table 2.

Table 2. Digital RC Corner Frequencies (Does not include correction time in calculation)

CELL_ADC_CO NF1[FILSHIFT]	Typical Corner Frequency (Hz) DR=256	Typical Corner Frequency (Hz) DR=128	Typical Corner Frequency (Hz) DR=64	Typical Corner Frequency (Hz) DR=32
0b000	180.1	360.2	720.4	1440.8
0b001	83.1	166.2	332.4	664.8
0b010	40.1	80.2	160.4	320.8
0b011	19.7	39.4	78.8	157.6
0b100	9.8	19.6	39.2	78.4
0b101	4.9	9.8	19.6	39.2
0b110	2.4	4.8	9.6	19.2
0b111	1.2	2.4	4.8	9.6

The single pole digital filter responds in the same way as an analog RC circuit responds, meaning that unless conversions are run continuously through the filter there is a step response that must be taken into account before reading the value for the first time. The step response of each corner frequency setting is shown below. This step response should be taken into account whenever starting up the conversions after coming out of SLEEP or SHUTDOWN modes or a significant jump in the input. Once the output voltage gets through the step response the host can read the voltage at any time interval to have a snapshot of the cell voltage.

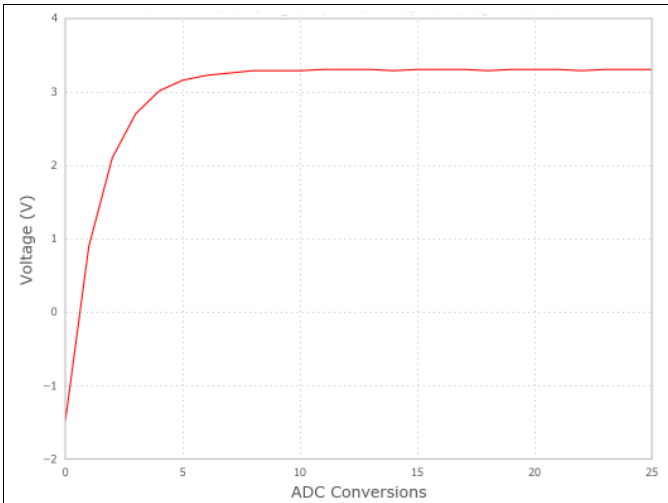

Reported Voltage w/3.3 V Input at  $f_C = 180.1$  Hz  
**Figure 8. FILSHIFT = 3'b000 Step Response, DR=256**

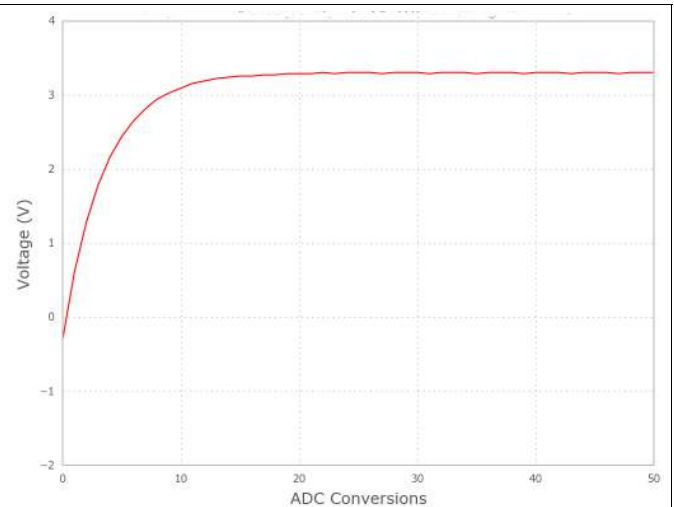

Reported Voltage w/3.3 V Input at  $f_C = 83.1$  Hz  
**Figure 9. FILSHIFT = 3'b001 Step Response, DR=256**

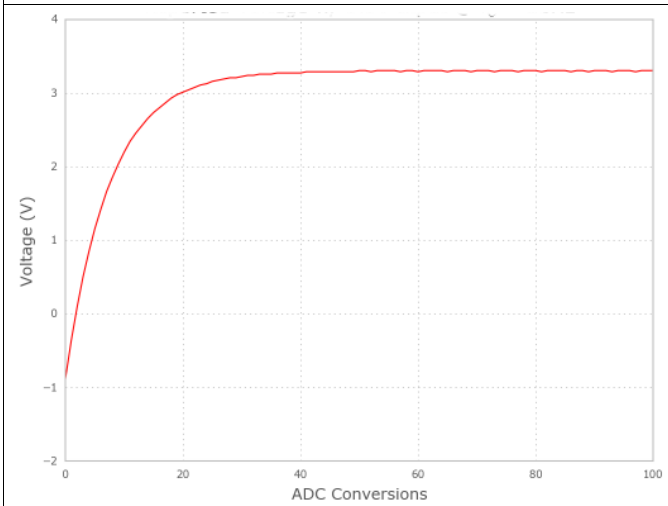

Reported Voltage w/3.3 V Input at  $f_C = 40.1$  Hz  
**Figure 10. FILSHIFT = 3'b010 Step Response, DR=256**

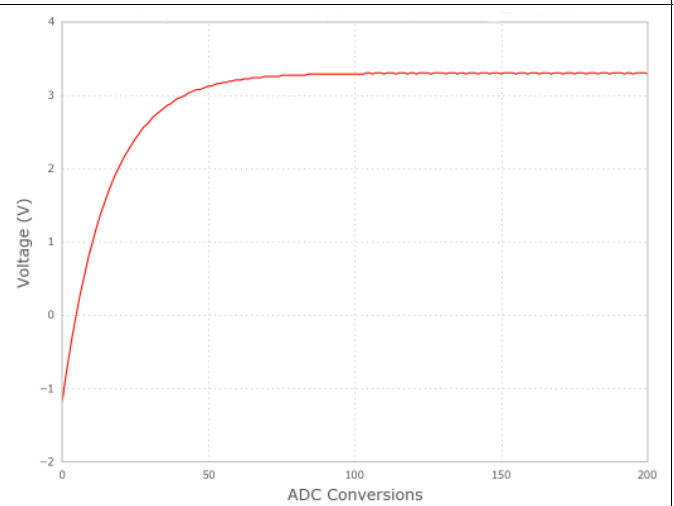

Reported Voltage w/3.3 V Input at  $f_C = 19.7$  Hz  
**Figure 11. FILSHIFT = 3'b011 Step Response, DR=256**

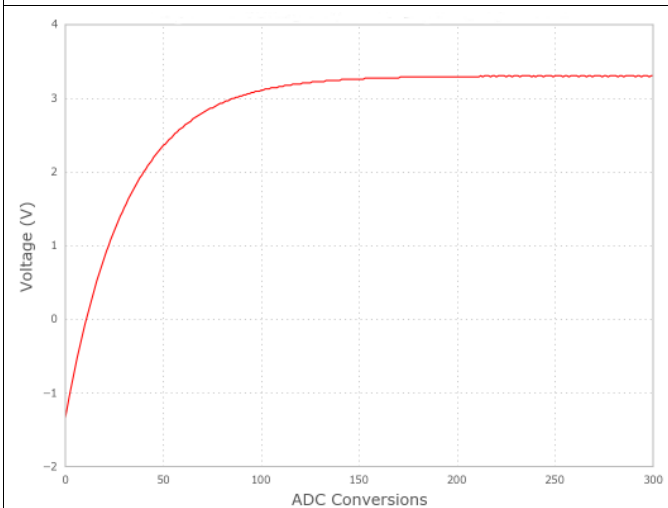

Reported Voltage w/3.3 V Input at  $f_C = 9.8$  Hz  
**Figure 12. FILSHIFT = 3'b100 Step Response, DR=256**

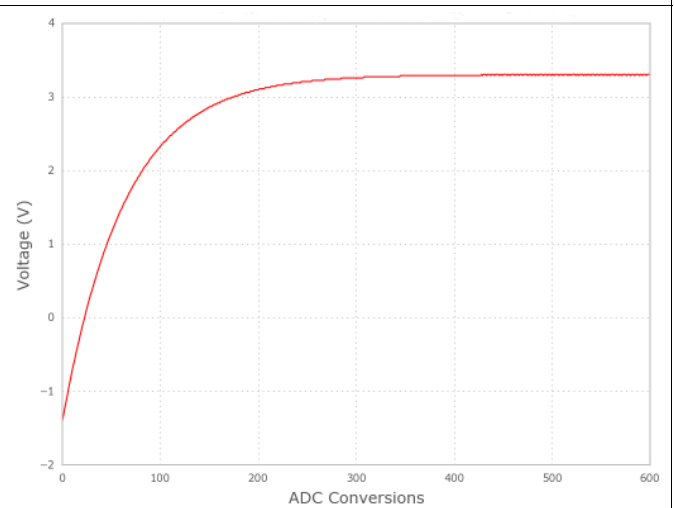

Reported Voltage w/3.3 V Input at  $f_C = 4.9$  Hz  
**Figure 13. FILSHIFT = 3'b101 Step Response, DR=256**

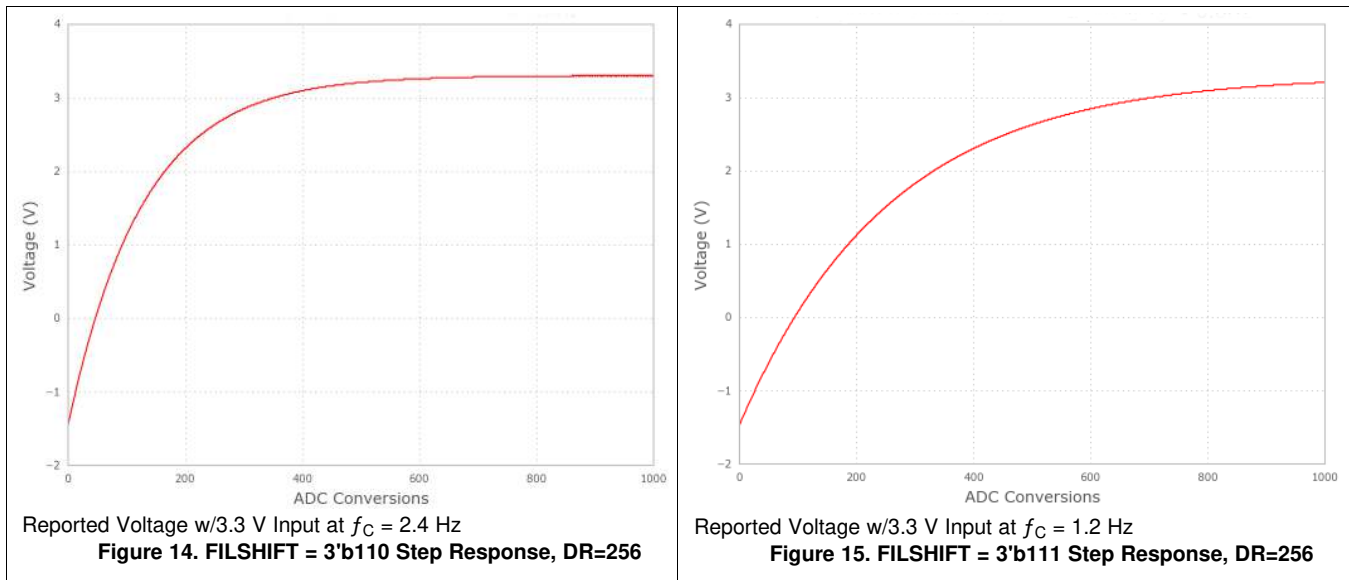

### 8.3.4.2 CELL ADC

ADC measurements for the cell voltages inputs are available either on-demand (single conversion) or continuously (with optional programmed delay between conversions). The ADCs integrated into the BQ79606A-Q1 are capable of 16-bit resolution for the corrected measurement or 24-bit resolution for the uncorrected measurements. Corrected values are 16 bits and are presented in H and L registers. Uncorrected values are 24-bit and are presented in H, M, and L registers.

#### NOTE

The measurement results require multiple registers. Reads must be done starting with the H byte register. This locks the M (when applicable) and L registers to ensure that the read values come from the same measurement and do not change mid-read. Best practice is to "burst read" all of the registers of interest. This note applies for AUX and DIE temperature ADCs as well.

The VC\* inputs measure voltages of -2V to 5V (cells 2-6, VC1 to VC6 and CB pins not connected) and 0V to 5V (cell 1, VC0 to VC1). Connect unused inputs to the highest-connected cell. For example, in a 4-cells system, connect the unused VC5 and VC6 inputs to VC4. Channels are used from lowest to highest, with VC0 connected to the (-) terminal of the bottom cell. To achieve the highest accuracy over temperature, the BQ79606A-Q1 samples the die temperature whenever a VC\* measurement is taken and then applies temperature correction to the ADC result to correct for any changes in the reference over temperature. Both the corrected and uncorrected values are available to be read by the host. The corrected non filtered values are in the VCELL\*H (higher byte) and VCELL\*L (lower byte) registers, and the lowpass filtered corrected results are contained in the VCELL\*\_HF (higher byte) and VCELL\*\_LF (lower byte). See the [Single Pole Digital Filter](#) for more details on the digital lowpass filter. The uncorrected non filtered values are in the VCELL\*\_HU (higher byte), VCELL\*\_MU (middle byte) and VCELL\*\_LU (lower byte) registers. The uncorrected values are available for the host to use to apply different correction coefficients. The uncorrected data also can be filtered if DIAG\_CTRL4[VCFILTSEL]=1 and DIAG\_CTRL4[CELUSEL]=1, the values are in the VCELL\*\_HU (higher byte), VCELL\*\_MU (middle byte) and VCELL\*\_LU (lower byte) registers. See [Table 3](#) for more details.

**Table 3. CELL ADC**

CELL ADC Parameter(s)	Filtered/corrected	Register(s)	Conversion (Equation)
VCELL1-6	Corrected and filtered	VCELL*_LF/HF	$VCELL^* = 190.7349 \mu V \times 2scomp$
	Corrected and non filtered	VCELL*L/H	$VCELL^* = 190.7349 \mu V \times 2scomp$
	Uncorrected and non filtered	VCELL*_LU/MU/HU	$VCELL^* = 0.745 \mu V \times 2scomp$
	Uncorrected and filtered	VCELL*_LU/MU/HU	$VCELL^* = 0.745 \mu V \times 2scomp$

The values returned from the ADC conversion for these channels are in 2's complement form. When converting the register value to a voltage, first the number must be converted from 2's complement to a decimal number as follows for 16-bits :

$$2_{scomp} = -a_{15} \times 2^{15} + \sum_{i=0}^{14} a_i \times 2^i \quad (1)$$

and for 24-bits

$$2_{scomp} = -a_{23} \times 2^{23} + \sum_{i=0}^{22} a_i \times 2^i \quad (2)$$

Where  $a_i$  is the bit value ( $a_{15}$  MSB to  $a_0$  LSB) of the measurement results from the ADC. The same equations applies for CELL ADC, AUX ADC, and DIE temperature ADC.

In order to provide the host a way to diagnose a "stuck value" in the result registers, the ADC output registers are initialized to 0x8000 for 16 bit data and 0x800000 for 24 bit data value with every ADC\_GO command. The 0x8000 and 0x800000 value are an impossible results to read under normal operating conditions and if read, the host easily recognizes this as an incorrect value and can act accordingly.

The host selects which measurements are to be done using the CELL\_ADC\_CTRL register. For the cell measurements (CELL\_ADC\_CTRL), enabling the channel, enables the internal level shifter to prepare for the ADC measurement. For best accuracy measurements, the host must wait at least  $t_{DLY(COM)}$  after enabling the cell channels before requesting a measurement to ensure proper settling time. The cells do not require enabling/disabling with every measurement. It is recommended that the cells are enabled and left on while the host is actively requesting ADC samples to avoid repeated delay times.

Once the channels are selected and settled, the CONTROL2[CELL\_ADC\_GO] is used to start the conversions. Additionally, a time delay may be added from when the CELL\_ADC\_GO bits are written to when the conversion starts using the ADC\_DELAY[DLY] bits. This allows the host to synchronize multiple measurements between separate devices (for example, synchronizing the cell measurements with an external current measurement).

#### 8.3.4.2.1 Continuous CELL ADC Conversions

To setup continuous ADC conversion, the host enables the cells using the CELL\_ADC\_CTRL register as with the single conversion case. Additionally, the host must set the CELL\_ADC\_CONF2[CELL\_CONT] bit. The conversion interval between cell ADC conversions is programmed using the CELL\_ADC\_CONF2[CELL\_INT] bit. After these registers are updated, the host must send a second write to set the CONTROL2[CELL\_ADC\_GO] bit.

Once the first conversion is complete, the ADC waits the programmed interval time (set by CELL\_ADC\_CONF2[CELL\_INT]) and starts the next conversion.

Once all of the cell conversions are complete for the first interval, the DEV\_STAT[DRDY\_CELL] is set. The DEV\_STAT[DRDY\_CELL] bit remains set after the first conversion during continuous conversions. The flag is cleared only when a new ADC conversion is initiated by writing the CONTROL2[CELL\_ADC\_GO] bit. Additionally, a 14-bit counter (CONV\_CNT\*) keeps track of the number of conversions done during the continuous conversion mode. The counter is incremented with every conversion. During continuous conversions, the last valid conversion results are always available in the results registers after the H byte register is read. To stop continuous conversions, the host must clear the ADC\_CONF2[CELL\_CONT] bit and then write the CONTROL2[CELL\_ADC\_GO] bit. This will begin one additional conversion, but the continuous conversions are discontinued.

During continuous conversions, any changes to the CELL\_ADC\_CONF\* and CELL\_ADC\_CTRL registers are ignored. To make changes during continuous conversions, the host must stop ADC conversions by clearing the CELL\_ADC\_CONF2[CELL\_CONT] bit and then writing the CONTROL2[CELL\_ADC\_GO] bit to stop the continuous conversions, update the CELL\_ADC\_CONF\*, and CELL\_ADC\_CTRL registers, and then set the CONTROL2[CELL\_ADC\_GO] bit to restart continuous conversions. For best results when using the single pole lowpass digital filter, the cell conversions must be set to continuous conversions with the minimum interval setting.

### 8.3.4.2.2 On-Demand CELL ADC Conversion (Single Conversion)

During on-demand reads, the host enables the desired cells using the CELL\_ADC\_CTRL register. After this register is updated, the host must wait at least  $t_{DLY(COM)}$  before sending a second write to set the CONTROL2[CELL\_ADC\_GO] bit to start the cell conversion. When the CELL\_ADC\_GO bit is set, the CELL ADCs simultaneously start the conversion with the enabled cell channels. The cell voltage conversions happen simultaneously. The results are available as the individual conversions complete. The DEV\_STAT[CELL\_STAT] bit is set while the respective ADCs are running. Once all of the cell conversions are complete, the CELL\_STAT bit is cleared and after the result(s) are updated in the registers the DEV\_STAT[DRDY\_CELL] bit is set. The host is ensured that the register information is current and may read the results from the conversion (read the H byte register to update the M and L bytes). If the host reads from the register prior to the conversion finishing, the 0x8000 diagnostic result is read. Writing to the CONTROL2[CELL\_ADC\_GO] bit during a cell conversion terminates the current conversion and begins a new conversion.

### 8.3.4.3 DIE Temperature ADC Measurement

To get maximum accuracy, an independent ADC (DIE temperature ADC) is used to measure the BQ79606A-Q1 die temperature. A die temperature reading is taken simultaneously with the cell measurements and used to correct the other ADC results for temperature variations in the die. To ensure the most accurate results, a cell ADC conversion must be done whenever an auxiliary ADC conversion is done to ensure the most recent temperature conversion is obtained. Otherwise, the last temperature result is used in the correction and may not be valid.

The junction temperature of the die is measured with every cell conversion (using CELL ADC). The reported result in the DIE\_TEMPL and DIE\_TEMP registers is the voltage from the temperature sensor. Similar to the voltages, the value in DIE\_TEMP\* is in 2's complement format. The die temperature is calculated using the equation listed in [Table 4](#)

**Table 4. DIE Temperature ADC**

TJ ADC Parameter	Registers	Conversion (Equation)
DIE Temperature	DIE_TEMPL/H	$TDIE = 0.02553 \text{ C} \times 2s_{comp}$

### 8.3.4.4 AUX ADC

#### 8.3.4.4.1 On-Demand AUX ADC Conversion (Single Conversion)

The AUX ADC does not support continuous conversion (unlike the CELL ADC). During on-demand reads, the host enables the desired cells or auxiliary inputs to convert using the AUX\_ADC\_CTRL\* registers. After these registers are updated, the host must send a second write to set the CONTROL2[AUX\_ADC\_GO] bit to start the auxiliary ADC conversion. When the AUX\_ADC\_GO bit is set, the AUX ADC starts the conversion with the first auxiliary ADC channel. The auxiliary conversions must sequence through each of the enabled channels in the sequence shown in [Figure 16](#).

#### NOTE

Reads must be done starting with the H byte register. This locks the M (when applicable) and L registers to ensure that the read values come from the same measurement and do not change mid-read. Best practice is to "burst read" all of the registers of interest.

The DEV\_STAT[AUX\_STAT] bit is set while the AUX ADC is running. Once all of the auxiliary ADC conversions are complete, the AUX\_STAT bit is cleared and after ALL of the results(s) are updated in the registers the DEV\_STAT[DRDY\_AUX] bit is set. Once the DRDY\_AUX bit is set, the host is ensured that the register information is current and may read the results from the conversion. If the host reads from a register prior to the conversion finishing, the 0x8000 diagnostic result will be read. Writing to the CONTROL2[AUX\_ADC\_GO] bit during an AUX conversion terminates the current conversion and restarts the full round-robin.

#### NOTE

If multiple channels are selected on the auxiliary ADC, the host must provide enough time for the measurements to finish before writing to the CONTROL2[AUX\_ADC\_GO] bit again. Otherwise, the auxiliary ADC resets and any unfinished conversions are not completed.



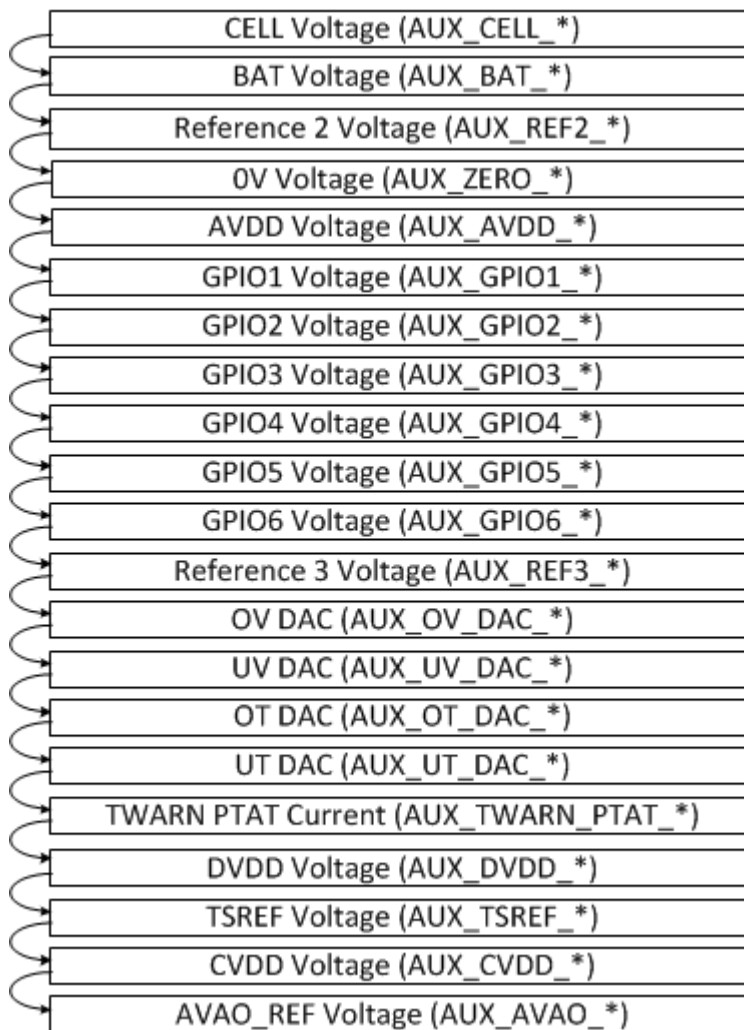

Figure 16. Auxiliary ADC Conversion Sequence

The following table summarizes all the AUX ADC parameters and the corresponding registers and the equation required to convert to voltage or temperature:

Table 5. AUX ADC

AUX Parameter(s)	Filtered/corrected	Register(s)	Conversion (Equation)
VCELL1-6	Corrected	AUX_CELL/H	$V_{AUX\_CELL} = 2 \times 190.7349 \mu\text{V} \times 2s_{\text{comp}}$
BAT	Uncorrected	AUX_BAT_LU/HU	$V_{\text{BAT}} = 2.827 \text{ mV} \times 2s_{\text{comp}}$
	Corrected	AUX_BATL/H	$V_{\text{BAT}} = 2.827 \text{ mV} \times 2s_{\text{comp}}$
REF2	Corrected	AUX_REF2L/H	$V_{\text{REF2}} = 190.7349 \mu\text{V} \times 2s_{\text{comp}}$
0V	Corrected	AUX_ZERO/H	$V_{\text{Zero}} = 190.7349 \mu\text{V} \times 2s_{\text{comp}}$
AVDD	Corrected	AUX_AVDDL/H	$V_{\text{AVDD}} = 381.622 \mu\text{V} \times 2s_{\text{comp}}$
GPIO1	Uncorrected	AUX_GPIO1_LU/MU/HU	$V_{\text{GPIO1}} = 0.745 \mu\text{V} \times 2s_{\text{comp}}$
	Uncorrected and Filtered if DIAG_CTRL4[AUXUSEL]=1	AUX_GPIO1_LU/MU/HU	$V_{\text{GPIO1}} = 0.745 \mu\text{V} \times 2s_{\text{comp}}$
	Corrected	AUX_GPIO1L/H	$V_{\text{GPIO1}} = 190.7349 \mu\text{V} \times 2s_{\text{comp}}$
GPIO2-6	Uncorrected	AUX_GPIO*_LU/HU	$V_{\text{GPIO}*} = 190.7349 \mu\text{V} \times 2s_{\text{comp}}$
	Corrected	AUX_GPIO*L/H	$V_{\text{GPIO}*} = 190.7349 \mu\text{V} \times 2s_{\text{comp}}$
REF3	Corrected	AUX_REF3L/H	$V_{\text{REF3}} = 190.7349 \mu\text{V} \times 2s_{\text{comp}}$

**Table 5. AUX ADC (continued)**

AUX Parameter(s)	Filtered/corrected	Register(s)	Conversion (Equation)
OV DAC	Corrected	AUX_OV_DACL/H	VOV_DAC=190.7349 uV x 2scomp
UV DAC	Corrected	AUX_UV_DACL/H	VUV_DAC=190.7349 uV x 2scomp
OT DAC	Corrected	AUX_OT_DACL/H	VOT_DAC=190.7349 uV x 2scomp
UT DAC	Corrected	AUX_UT_DACL/H	VUT_DAC=190.7349 uV x 2scomp
TWARN_PTAT	Corrected	AUX_TWARN_PTATL/H	VTWARN_PTAT=190.7349 uV x 2scomp
DVDD	Corrected	AUX_DVDDL/H	VDVDD=190.7349 uV x 2scomp
TSREF	Corrected	AUX_TSREFL/H	VTSREF=190.7349 uV x 2scomp
CVDD	Corrected	AUX_CVDDL/H	VCVDD=548.47 uV x 2scomp
AVAO_REF	Corrected	AUX_AVAOL/H	AVAO_REF=190.7349 uV x 2scomp

#### 8.3.4.4.2 AUX CELL Voltage

The AUX ADC has an input for a selected cell voltage. The cell voltage is measured through the CB1-6 pins. This is useful for comparing to the VC1-6 results from CELL ADC to ensure correct operation of the cell ADCs. Each cell is selectable using the DIAG\_CTRL2[AUX\_CELL\_SEL] bit. This bit should be cleared first whenever AUX\_CELL\_SEL is changed. Selecting a cell using the AUX\_CELL\_SEL bits and enabling the function with DIAG\_CTRL2[AUX\_CELL\_SEL\_EN] routes the cell voltage from the OVUV level shifter to the AUX ADC. Additionally, selecting a cell enables the AUX\_CELL measurement for the auxiliary ADC. Refer to [Table 5](#) for more detail about AUX\_CELL1-6 measurements details. While the DIAG\_CTRL2[AUX\_CELL\_SEL] bit is set to 1, the OVUV function is suspended.

#### NOTE

The AUX ADC only supports positive voltage readings. When comparing the AUX\_CELL measurement, only voltages from 0V to 5V are supported.

The data for the cell voltages is 16-bit (spread over two registers). To prevent the condition where a read of the full data results in data split between two reads (i.e. AUX\_CELLH from first conversion and AUX\_CELLL from second ADC conversion due to conversion update in the middle of a read), data for all registers for a single input are locked. For example, AUX\_CELLL is locked for updates until AUX\_CELLH is read. The BQ79606A-Q1 does not support reading only the MSB or LSB. The best practice is to group read all registers for a particular input.

#### 8.3.4.4.3 AUX GPIO Input Measurement

The GPIO1 to GPIO6 input channels are available to be used to measure either ratiometric inputs (when in TS mode) or external analog voltages from 0 V to 5 V. Select the absolute or ratiometric for the individual GPIOs using the GPIO\_ADC\_CONF register. The GPIOs are enabled using the AUX\_ADC\_CTRL1[GPIO\*\_EN] bits.

When in Temperature Sensing "TS" operation, a resistor divider is connected from TSREF to AVSS with GPIO connected to the center tap. This linearizes the NTC curve and improves the resolution at extreme temperatures. The circuit is shown in [Figure 17](#). Ensure that TSREF is enabled (using CONTROL2[TSREF\_EN]) and settled before running any GPIO conversions.



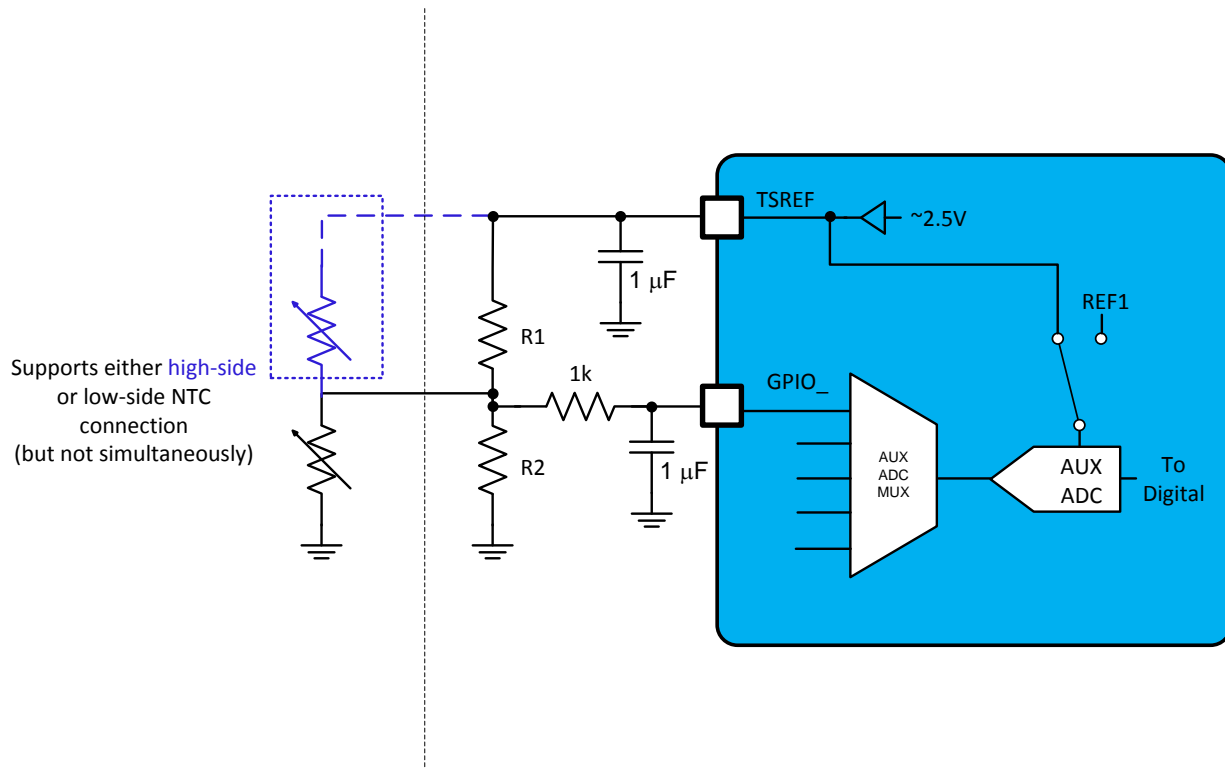

Figure 17. NTC Linearization Circuit

The GPIO\* voltage measurements are available with uncorrected values (to registers AUX\_GPIO1\_HU (MSB), AUX\_GPIO1\_MU (middle byte) and AUX\_GPIO1\_LU (LSB) for GPIO1 and AUX\_GPIO\*HU (MSB) and AUX\_GPIO\*\_LU (LSB) for GPIO2-6). The ratiometric ADC conversion result when in TS operation is calculated as:

$$\%_{TSREF} = 0.00007628\% \times 2scomp \quad (3)$$

To achieve the highest accuracy over temperature, a cell measurement must be taken to ensure the latest die temperature information is available for the correction. The absolute ADC conversion result when in absolute operation is calculated as:

$$V_{CHANNEL} = 190.7349 \mu V \times 2scomp \quad (4)$$

The data for the GPIO1-6 voltages is 16-bit (spread over two registers) for the corrected and the uncorrected data (24-bit for the uncorrected data for GPIO1 only). To prevent the condition where a read of the full data results in data split between two reads (i.e. AUX\_GPIO\*H from first conversion and AUX\_GPIO\*L from second ADC conversion due to conversion update in the middle of a read), data for all registers for a single input are locked. For example, AUX\_GPIO1\_LU and AUX\_GPIO1\_MU are locked for updates until AUX\_GPIO1\_HU is read. The best practice is to group read all registers for a particular input.

#### 8.3.4.4.4 AUX BAT Measurement

V<sub>BAT</sub> is the voltage measured from BAT to AVSS. Set the AUX\_ADC\_CTRL1[BAT\_EN] bit to enable the BAT voltage monitoring. The stack voltage measurement is available with corrected values (registers AUX\_BATH (MSB) and AUX\_BATL (LSB)) and uncorrected values (to registers AUX\_BAT\_HU (MSB) and AUX\_BAT\_LU (LSB)). The values returned from an ADC conversion for this channel is converted to voltage as in Table 5.

The data for the BAT voltage is 16-bit (spread over two registers) for the corrected data and 24-bit (spread over three registers) for the uncorrected data. To prevent the condition where a read of the full data results in data split between two reads (i.e. AUX\_BATH from first conversion and AUX\_BATL from second ADC conversion due to conversion update in the middle of a read), data for all registers for a single input are locked. For example, AUX\_BATL and is locked for updates until AUX\_BATH is read. The best practice is to group read all registers for a particular input. The BQ79606A-Q1 does not support reading only the MSB or LSB.

#### 8.3.4.4.5 Power Rail, DAC, References, and 0V Measurements

The auxiliary ADC has inputs for the power supplies: AVDD (result in AUX\_AVDD\*), CVDD (result in AUX\_CVDD\*), DVDD (result in AUX\_DVDD\*), and TSREF (result in AUX\_TSREF\*) voltages. The value returned from an ADC conversion for AVDD and CVDD channels is converted to voltage by:

$$V_{CVDD} = 548 \mu\text{V} \times 2s_{\text{comp}} \quad (5)$$

$$V_{AVDD} = 381.622 \mu\text{V} \times 2s_{\text{comp}} \quad (6)$$

The auxiliary ADC has inputs for several important references for use with diagnostics and during developmental debugging: 0V (result in AUX\_ZERO\*), REF2 (result in AUX\_REF2\*), REF3 (result in AUX\_REF3\*), the AVAO\_REF reference (result in AUX\_AVAO\*), and half of the OVUV reference (1/2 OVUV reference) and the OTUT reference results in AUX\_UV\_DAC\*, AUX\_OV\_DAC\*, AUX\_UT\_DAC\*, and AUX\_OT\_DAC\*, respectively. The value returned from an ADC conversion for these channels (including DVDD) is converted to voltage as shown in [Table 5](#)

There is no internal threshold checking of these values. The expectation is that the microcontroller checks that the values are within the appropriate ranges.

#### NOTE

The AUX\_UV\_DAC and AUX\_OV\_DAC reports 1/2 of the OVUV reference voltage.

#### 8.3.4.4.6 VWARN PTAT measurement

The input for the TWARN PTAT voltage (result in AUX\_TWARN\_PTAT\*) for use with diagnostics and during developmental debugging. VWARN PTAT can be related directly to the temperature using this equation:

$$\text{TWARN\_PTAT (C)} = 25\text{C} + ([V_{\text{WARNPTAT}}\text{mV} - 330\text{mV} - V_{\text{PTAT\_OFFSET}}\text{mV}] / (1.17\text{mV/C})) \quad (7)$$

$V_{\text{PTAT\_OFFSET}}$  is programmed offset in hex and located in register SPARE\_6 and converted to mV using this equation:

$$V_{\text{PTAT\_OFFSET}} \text{ mV} = 1\text{mV} \times 2s_{\text{comp}} \quad (8)$$

In addition to the normal channel selection in the AUX\_ADC\_CTRL\* register, the VPTAT input must be enabled. Before a measurement is taken for TWARN PTAT, set the CONTROL2[VPTAT\_EN] bit to enable the input. After the conversion is complete, disable the input by clearing the CONTROL2[VPTAT\_EN] bit. This prevents noise from coupling on to internal circuits during normal operation.

### 8.3.5 Cell Balancing

The BQ79606A-Q1 integrates a MOSFET for each cell to enable passive balancing with a minimum of external components. Passive cell balancing slowly discharges individual higher voltage cells to balance the voltage across all of the cells in the stack. Cell balancing reduces the aging rate differences between cells to extend the battery pack overall lifetime. The drawback to passive balancing is heat generation. The energy during discharge is dissipated across an external resistor generating heat. The cell balancing current must be chosen as a tradeoff between the time it takes to balance and the heat generated in the process. The cell balancing algorithm is fully configurable and runs autonomously once enabled. Cell balancing is terminated either when the individual timer expires, or the cell voltage reaches a programmed threshold.

External resistors set the cell balancing current. [Figure 18](#) illustrates the circuit and current flow during balancing. Cell balancing is available with a CBDONE comparator function for cell voltages greater than 2.8V. ADC reads are available during cell balancing. Cell balancing sequencing is programmable to balance cells in two banks, the odd cells and the even cells. Additionally, a cell balancing comparator is integrated that monitors the cell voltages and terminates cell balancing once the voltage  $V_{\text{CBDONE}}$  threshold is reached. The cell balancing time is programmable for each individual cell. Additionally, a duty cycle timing function is built into the BQ79606A-Q1 to switch between banks during balancing to achieve a simultaneous stack balance. Using these timing features, the host microcontroller controls the specific algorithm used for cell balancing.

While active, the status of the individual cell balancing switch is indicated in the CB\_SW\_STAT register. As the cell balancing for each cell completes, the CB\_DONE register is updated. When the timer or voltage is satisfied for a particular cell, the switch is disabled and the corresponding CB\_DONE[CELL\*] bit is set.

---

**NOTE**

The CB pins must NEVER be connected to cell voltages (module connectors) that are expected to be negative. The internal FET diode will conduct and likely damage the FET in reverse voltage conditions.

---



### 8.3.5.1.1 Cell Voltage Monitoring Setup

The cell balancing done comparator threshold ( $V_{\text{CBDONE}}$ ) is configurable using the CB\_DONE\_THRESH register. The voltage selected is set for all cells. The cells that are being balanced are monitored by a single comparator in a "round robin" fashion. The comparator tests the voltage for  $t_{\text{CYCLE}}$ . Additionally, the comparator signal is deglitched for  $t_{\text{dgOVUVCB}}$  (set using the COMP\_DG[OVUV\_DG] bits). The deglitch is a count up/down style deglitch. During the monitoring cycle, the comparator checks the voltage. A counter is incremented when the comparator is tripped, and decremented when the comparator is not tripped. Once the counter reaches the threshold, the cell balancing switch is disabled and the corresponding CB\_DONE[CELL\*] bit is set. Once the cell balancing for that cell is terminated, the cell balancing does not restart for the remainder of the cell balancing sequence regardless of the cell voltage. Similar to the hardware comparators, the cell balancing comparator may be programmed to perform BIST as it is monitoring the cell voltages. The BIST is identical to the OVUV BIST as described in [CB\\_DONE, OVUV, and OTUT Built-In Self Test \(BIST\)](#). Once the cell balancing is enabled (CONTROL2[BAL\_GO]=1), changes to the CB\_DONE\_THRESH and CB\_DONE registers are ignored until the cycle is completed (CB\_DONE is cleared when CONTROL2[BAL\_GO] is set). Cell balancing must be disabled and then restarted to be able to change the settings.

The CBDONE function overrides the OVUV function (if enabled). During the cell balancing cycle, with CBDONE enabled, the OVUV function is paused (if enabled).

CB\_DONE\_THRESH[ENABLE] bit controls the CBDONE comparator function, when the bit is set to 0 it disables the CBDONE comparator.

### 8.3.5.1.2 Timer Setup and Configuration

The individual cell balancing timers are programmable using the CB\_CELL\*\_CTRL registers. The cell balancing time is programmable from 0 (no balance) to 127min. Once the cell balancing is enabled (CONTROL2[BAL\_GO]=1), changes to the CB\_CELL\*\_CTRL registers are ignored. Cell balancing must be disabled and then restarted to be able to change the timer settings. To stop cell balancing before completion, all timers must be set to 0 and then write CONTROL2[BAL\_GO] = 1.

---

#### NOTE

Writing a **0** to the cell balance timer bit field in the register disables cell balancing for that cell for a given CONTROL2[BAL\_GO]=1 command and does not execute the balancing sequence .

---

Balancing is available during SLEEP mode. To enable balancing during SLEEP mode, configure the balancing timers and thresholds first and then execute cell balancing using the CONTROL2[BAL\_GO] command. Finally, set the CONTROL1[GOTO\_SLEEP] bit. To stop balancing while in SLEEP mode, a SLEEPtoACT or WAKE (wake tone for stack devices or hold WAKEUP pin low for base device for  $t_{\text{HDL\_WAKE}}$ ) must be sent to the device before disabling balancing. Note that if a WAKE is sent, it is unnecessary to disable balancing as the device is reset.

### 8.3.5.1.3 Cell Balance Sequencing

Once all of the parameters are set and the sequencing is selected, write the CONTROL2[BAL\_GO] bit to 1 to start the cell balancing. When the BAL\_GO bit is set, all of the configuration registers are sampled. Any changes to the configuration registers are ignored during the balancing cycle. A second BAL\_GO must be performed to change any settings. Once enabled, balancing proceeds according to the flowchart in [Figure 19](#). The DEV\_STAT[CB\_RUN] bit is set for the entire cell balancing cycle, regardless if paused. It is cleared once the DEV\_STAT[CB\_DONE] bit is set.

During non-duty cycle operation CB\_CONFIG[DUTY]=00, when an individual cell's balancing timer expires or the voltage falls to the programmed threshold, the balancing FET for that cell is disabled, the CB\_DONE[CELL\*] bit is set for that cell, and any cells with remaining time continue to balance. Once all of the selected bank of cells have completed balancing (either by timer expiration or voltage), the second bank (if selected) are balanced using the same procedure. Once all of the cells in that bank are balanced, the DEV\_STAT[CB\_DONE] bit is set, indicating that balancing is complete. The host is not required to monitor the balancing once the CONTROL2[BAL\_GO] bit is set, allowing the host to enter a low power mode. Note that when cell balancing is disabled for a cell that is in a bank to be balanced (by setting the timer to 0), the corresponding

CB\_DONE[CELL\*] bit is set immediately after the BAL\_GO bit is set. When only balancing even or odd cells (CB\_CONFIG[SEQ] = 0b00 or 0b01), only the bank that is balanced updates the CB\_DONE[CELL\*] bits. The CB\_DONE[CELL\*] bits for the non-balanced bank of cells are reset with the BAL\_GO command, but are not modified during the balancing operation. For instance, after a completed cell balancing cycle where only the odd cells are balanced, the CB\_DONE register reads (assuming no faults during the cell balancing) 0x15.

With duty cycle operation enabled (CB\_CONFIG[DUTY] ≠ 00), the sequence follows the CB\_CONFIG[SEQ] programming. The duty cycle timer runs in parallel with the cell timers. The odd or even cell balancing runs for the time programmed in CB\_CONFIG[DUTY] and CB\_CONFIG[DUTY\_UNIT] and then switches to the other bank for the programmed time. The process continues switching back and forth until all of the cells are balanced. If all cells in a particular bank have completed, while some remain in the second bank, the device does not switch to the completed bank and, instead remains on the unfinished bank until all cells complete.

Cell balancing is paused using the CB\_SW\_EN[CB\_PAUSE] bit. When set, the cell balancing state machine is frozen and all switches are turned off and the DEV\_STAT[CB\_PAUSE] bit is set. Cell balancing must be paused before doing diagnostics. If a fault occurs while cell balancing is in the pause state, nothing happens to the cell balancing logic, regardless of the state of the CB\_CONFIG[FLTSTOP] bit. If the fault exists when the CB\_PAUSE bit is cleared, the cell balancing takes action at that point based on the state of the FLTSTOP bit.

---

**NOTE**

The CB\_CONFIG[DUTY\_UNIT] and the CB\_CELL1\_CTRL[TIME\_UNIT] unit must be the same. If minutes is selected for CB\_CONFIG[DUTY\_UNIT] minutes must be selected for CB\_CELL1\_CTRL[TIME\_UNIT] as well.

---

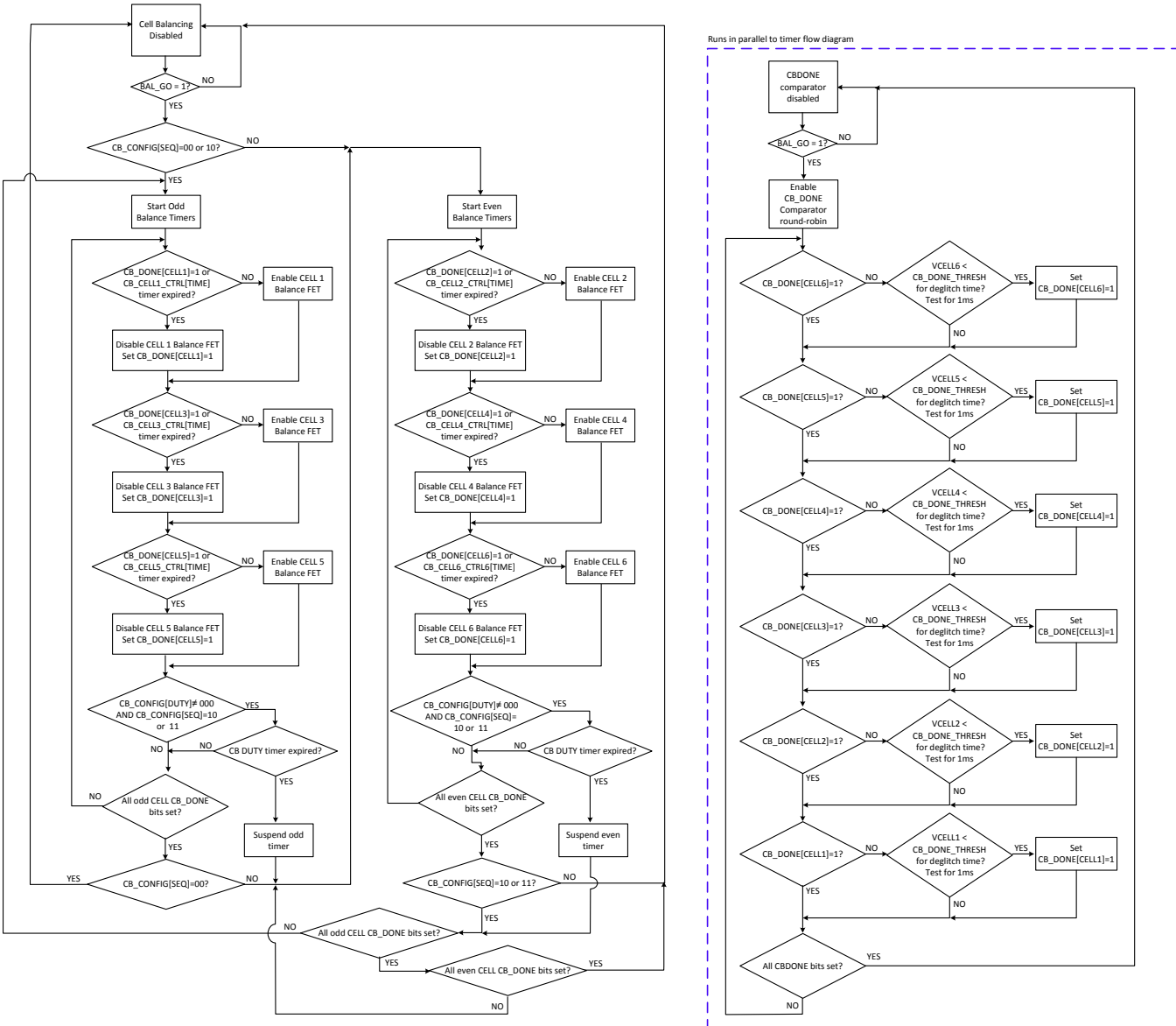

Figure 19. Flow Diagram for Cell Balancing

8.3.5.1.4 Manual Cell Balance Switch Enable

The cell balancing switches may be enabled separately from the normal cell balancing cycle. Use the CB\_SW\_EN[CELL\*\_EN] bits to select the individual cell balancing switches. Do not select adjacent switches to be enabled simultaneously. Setting the CB\_SW\_EN[SW\_EN] bit enables the selected switches. If adjacent switches are selected, none of the switches are enabled. As with the normal cell balancing cycle, the state of the cell balance switch is read using the CB\_SW\_STAT register. The manual cell balance switch function does not work if normal cell balancing is running. The normal cell balance cycle must either be stopped, done, or paused. If cell balancing is running, writing the CB\_SW\_EN[SW\_EN] has no effect. Note that the settings are read and the selected switches enabled when SW\_EN is written from '0' to '1'. Cell balancing must be paused or disabled and then SW\_EN must be written to '0' and then rewritten to '1' to enable the function.

8.3.5.2 Cell Balance Diagnostics

The cell balancing circuits integrate features that enable the user to diagnose issues with CB and VC open-wire as well as cell balance switch damage. In addition to the normal cell balancing flow, the cell balance switches can be manually enabled. Additionally, there are integrated comparators to diagnose the switch damage.



### 8.3.5.2.1 Cell Balance Switch Comparators

There are two comparators integrated with each switch (CBVC and VCLOW). The comparators are enabled with the CBVC\_COMP\_CTRL[CELL\*] bits. The first comparator tests the voltage across CBn to CBn-1 and compares it to  $(VCn - VCn-1)/3$ . If the CB voltage is greater than the VC/3 voltage, a flag (CBVC\_COMP\_STAT[CELL\*]) is set. After the comparator is turned on, it takes up to 2.5ms to update the CBVC\_COMP\_STAT[CELL\*] register status bits. Give 2.5ms delay time before reading the status register. The second comparator checks if the cell voltage  $(VCn - VCn-1)$  is above  $V_{VCLOW}$ . If the cell voltage is less than  $V_{VCLOW}$ , a flag (CBVC\_VCLOW\_STAT[CELL\*]) is set. If the cell voltage is low, the result from CBVC\_COM\_STAT must not be trusted. Charge the cells further before retrying the test.

### 8.3.5.2.2 CB Current Sinks and Sources

The CB\_CS\_CTRL register allows the host to enable current sinks (CB1-CB6) or current source (CB0) to attempt to pull the pin up/down to diagnose a CB open-wire condition. There are no internal comparisons done on the pins, it is up to the host to diagnose an open-wire condition using the ADC. The current sources/sinks are limited to  $I_{OWSNK}$  and  $I_{OWSRC}$ , therefore special attention must be paid to the size of the external components and the time it takes to discharge any external capacitance.

## 8.3.6 Integrated Hardware Protector

The BQ79606A-Q1 integrates secondary hardware protections along with the ADC monitoring functions. A window comparator is integrated for each cell to check over-voltage and under-voltage. Additionally, a thermal shutdown function is included to disable operation under extreme thermal stresses.

### 8.3.6.1 Cell Voltage Window Comparators

A set of window comparators provides cell voltage monitoring for all six channels that is separate from the main acquisition path and works in parallel with the main ADC route. This comparator function is entirely separate from the ADC function and as such, even if the ADC function fails, the analog comparators still flag the crossing of the (register selectable) under-voltage and over-voltage comparator thresholds. The thresholds, and deglitch timing are programmable and are the same for all cells. Each cell has independent on/off control. An internal DAC sets the over-voltage and under-voltage thresholds. The DAC uses a separate reference circuit REF2 from the ADC reference REF1. The OV threshold is programmable to OFF or from 2V to 5V in steps of 25 mV using the OV\_THRESH register. The UV threshold is programmable to OFF or from 0.7 V to 3.875 V in steps of 25 mV using the UV\_THRESH register.

Use the OVUV\_CTRL[CELL\*\_EN] bits to enable the cells that are required for OV/UV monitoring. Use the CONTROL2[OVUV\_EN] bit to enable the comparators. When enabled, all of the configuration bits are read. Further changes to the registers have no effect until the OVUV\_EN bit is cleared and set again.

Once enabled, the cells are monitored in a "round-robin" fashion, starting with CELL1 and cycling through to CELL6. The total time taken to do the round-robin cycle is  $t_{CYCLE}$ . The monitoring time for each CELL input is  $t_{RR\_SLOT}$ . The LOOP\_STAT[OVUV\_LOOP\_DONE] bit is updated at the end of each round-robin cycle (including the BIST, if enabled). See [CB\\_DONE](#), [OVUV](#), and [OTUT Built-In Self Test \(BIST\)](#) for details). If already set, the bit remains as 1 until cleared by a read.

The deglitch time is programmed using the COMP\_DG[OVUV\_DG] bits. The deglitch is a count up/down style deglitch. During the monitoring cycle, the comparator checks the voltage. A counter is incremented when the comparator is tripped, and decremented when the comparator is not tripped. Once the counter reaches the programmed threshold, the OV\_FAULT[CELL\*] or UV\_FAULT[CELL\*] bit (depending on which comparator trips) is updated, and, if unmasked, the NFAULT output and/or the FAULT\* interface signals the fault to the host. Note that due to the round-robin architecture, the total delay for an OV or UV event may be as high as  $(t_{CYCLE} - t_{RR\_SLOT}) + 0.7ms$ .



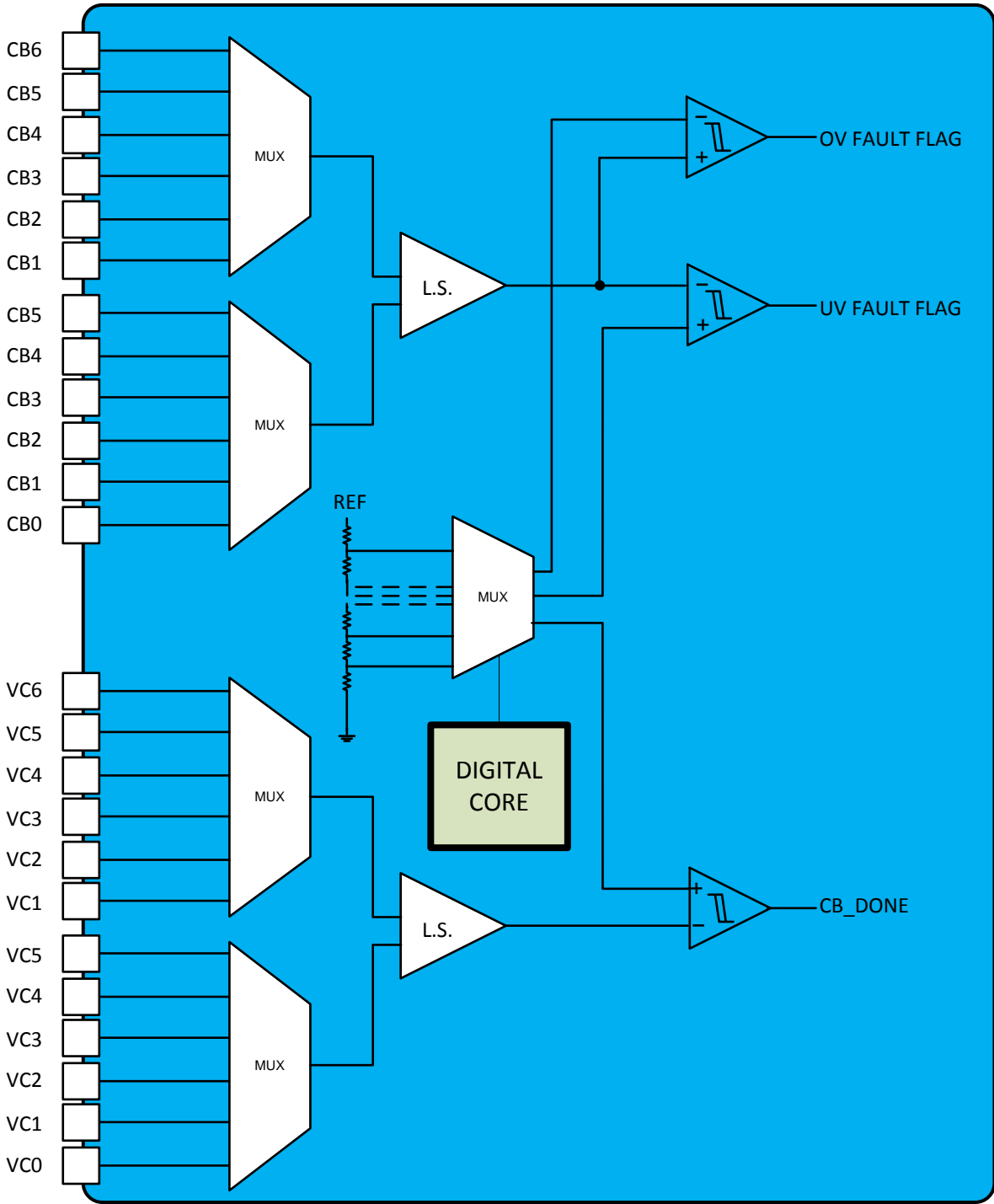

Figure 20. Window Comparator Circuit

The OVUV function will not function if enabled during cell balancing as it uses the CB\* inputs for sensing. Additionally, during the cell balancing cycle, with CBDONE enabled, the OVUV function is paused (if enabled). The UVOV comparators stop running during cell diagnostics.

### 8.3.6.2 Cell Over/Under-Temperature Comparators

A window comparator is integrated to monitor the GPIO1 to GPIO6 inputs for over-temperature and under-temperature conditions in the cells. When enabled, the comparator cycles through each of the temperature sense inputs and compares the voltage to thresholds programmed in the OTUT\_THRESH register. This comparator function is entirely separated from the ADC function and as such, even if the ADC function fails, the analog comparators flag the crossing of the (register selectable) under-temperature and over-temperature comparator thresholds. The thresholds and deglitch timing are programmable and apply for all six inputs. Two internal DACs set the separate over-temperature and under-temperature thresholds. The OT threshold is programmable to OFF or from 20% to 35% of TSREF in steps of 1% using the OTUT\_THRESH[OT\_THRESH] bits. The UT threshold is programmable to OFF or from 60% to 75% of TSREF in steps of 1% using the OTUT\_THRESH[UT\_THRESH] bits. TSREF must be enabled (CONTROL2[TSREF\_EN]=1) for at least 2ms (for the recommended capacitor value, larger capacitors may lead to longer startup time) before enabling the OT/UT function. Failure to do so results in all of the OT\_FAULT and UT\_FAULT bits being set. Additionally, if a TSREF OV/UV fault happens at any time during OT/UT operation, all of the OT\_FAULT and UT\_FAULT bits are set.

Use the OTUT\_CTRL register to enable the GPIOs that are required for OT/UT monitoring. Use the CONTROL2[OTUT\_EN] bit to enable the comparators. When enabled, all of the configuration bits are read. Further changes to the registers have no effect until the OTUT\_EN bit is cleared and set again.

Once enabled, the comparators are monitored in a "round-robin" fashion, starting with GPIO1 and cycling through to GPIO6. The total time taken to do the round-robin cycle is  $t_{CYCLE}$ . The monitoring time for each GPIO input is  $t_{RR\_SLOT}$ . The LOOP\_STAT[OTUT\_LOOP\_DONE] bit is updated at the end of each round-robin cycle (including the BIST, if enabled. See [CB\\_DONE](#), [OVUV](#), and [OTUT Built-In Self Test \(BIST\)](#) for details). If already set, the bit remains as 1 until cleared by a read.

The deglitch time for the OT and UT comparators is programmed using the COMP\_DG[TEMP\_DG] bits. The deglitch is a count up/down style deglitch. During the monitoring cycle, the comparator checks the voltage. A counter is incremented when the comparator is tripped, and decremented when the comparator is not tripped. Once the counter reaches the programmed threshold, the OT\_FAULT[GPIO\*] or UT\_FAULT[GPIO\*] bit (depending on which comparator trips) is updated, and, if unmasked, the NFAULT output (for base device) and/or the FAULT\* interface (for the stack device) signals the fault. Note that due to the round-robin architecture, the total delay for an OT or UT event may be as high as:  $(t_{CYCLE} - t_{RR\_SLOT}) + 0.1ms$ .

### 8.3.6.3 CB\_DONE, OVUV, and OTUT Built-In Self Test (BIST)

The CBDONE, OVUV and OTUT comparators contain a BIST function for diagnostic purposes. When enabled, the BIST tests each of the individual comparators. The BIST is enabled for the OVUV comparators using the DIAG\_CTRL1[OVUV\_MODE] and DIAG\_CTRL1[OTUT\_MODE] bits. There are three options: Perform the round-robin with BIST enabled, perform the round robin with BIST disabled, and single channel mode, where the comparators remain fixed on a selected input. When the BIST is enabled (DIAG\_CTRL1[OVUV\_MODE] = 0b00, DIAG\_CTRL1[OTUT\_MODE] = 0b00), the BIST is run on every other round robin cycle. This ensures that the BIST is run within two times  $t_{CYCLE}$ .

The comparator is tested by comparing a diagnostic DAC voltage (generated from REF2) to the selected threshold. The diagnostic DAC voltage is switched from 2 LSB below the threshold to 2 LSB above the threshold and the output of the comparator is checked to ensure it switches. If the comparator does not switch, the corresponding bit is set as follow:

- For OV comparator: OVUV\_BIST\_FAULT[OVCOMP]
- For UV comparator: OVUV\_BIST\_FAULT[UVCOMP]
- For OT comparator: OTUT\_BIST\_FAULT[OTCOMP]
- For UT comparator: OTUT\_BIST\_FAULT[UTCOMP].

The VCBDONE comparator BIST follows the same process and is enabled by the DIAG\_CTRL1[OVUV\_MODE] bits. If the BIST fails during the VCBDONE comparator BIST test, the SYS\_FAULT3[CB\_VDONE] bit is set. All signals during BIST are deglitched by  $t_{BISTDG}$ .

### 8.3.6.4 Single Comparator Mode

When the OVUV or OTUT comparators are programmed to single channel mode (DIAG\_CTRL1[OTUT\_MODE] = 0b10 or 0b11, DIAG\_CTRL1[OVUV\_MODE] = 0b10 or 0b11), the comparators are on for the lowest selected channel. The channel is selected using OVUV\_CTRL[CELL\*\_EN] bits for OVUV and OTUT\_CTRL[GPIO\*\_EN] bits for OTUT bits. It continuously monitors that channel and does not perform the BIST function. Cell Balancing should not be enabled during OVUV single comparator mode and also make sure to set the DIAG\_CTRL1[OVUV\_MODE] to 0b00 once the OVUV single mode is done.

#### 8.3.6.4.1 OTUT DAC Measurement

This mode is intended for OTUT DAC reference (detection threshold level) measurement in the AUX ADC. The sequence listed below should be followed for proper measurements. If OTUT is transitioned to the enabled state after the AUX ADC input is enabled and OTUT is set to single mode, the OTUT logic masks the output from the comparators. This ensures the DAC outputs only the detection threshold level during the ADC measurement. Transitioning the OTUT enable bit from disabled to enabled latches the mode configuration signals, therefore it is required whenever a configuration change is requested.

1. Set ADC input enable (OT\_DAC\_EN=1 or/and UT\_DAC\_EN=1 in AUX\_ADC\_CTRL2)
2. Set OTUT in single channel (set OTUT\_MODE in DIAG\_CTRL1 to 0b10)
3. Set at least one of channel enable (GPIO1\_EN=1 in OTUT\_CTRL for example)
4. Set OTUT disable (OTUT\_EN =0 in CONTROL2 ) if it is already enabled
5. Set OTUT enable (OTUT\_EN=1 in CONTROL2 )
6. Enable TSREF (TSREF\_EN=1 in CONTROL2)
7. wait for TSREF to settle
8. Start AUX ADC conversion (AUX\_ADC\_GO=1 in CONTROL2)
9. Wait for AUX ADC to finish
10. Re-configure OTUT as required.

#### 8.3.6.4.2 OVUV DAC Measurement

This mode is intended for OVUV DAC reference (detection threshold level) measurement in AUX ADC. The sequence listed below should be followed for proper measurements. If OVUV is transitioned to the enabled state after the AUX ADC input is enabled and OVUV is set to single mode, the OVUV logic masks the output from the comparators. This ensures the DAC outputs only the detection threshold level during the ADC measurement. Transitioning the OVUV enable bit from disabled to enabled latches the mode configuration signals, therefore it is required whenever a configuration change is requested.

1. Set ADC input enable (OV\_DAC\_EN=1 or/and UV\_DAC\_EN=1 in AUX\_ADC\_CTRL2)
2. If the AUX\_CELL is enabled make sure to set AUX\_CELL\_\_SEL\_EN=0 and AUX\_CELL\_SEL[2:0]=00 on the DIAG\_CTRL2 register
3. Set OVUV in single channel (set OVUV\_MODE in DIAG\_CTRL1 to 10)
4. Set at least one of channel enable (CELL1\_EN=1 in OVUV\_CTRL for example)
5. Set OVUV disable (OVUV\_EN =0 in CONTROL2 ) if it is already enabled
6. Set OVUV enable (OVUV\_EN=1 in CONTROL2 )
7. Start AUX ADC conversion (AUX\_ADC\_GO=1 in CONTROL2)
8. Wait for AUX ADC to finish
9. Re-configure OVUV as required

### 8.3.7 Thermal Shutdown and Warning

Thermal shutdown occurs when the Thermal Shutdown (TSD) sensor senses an over-temperature condition. The sensor operates without interaction and is separated from the ADC measured die sensor. The TSD function has a register-status indicator flag (SYS\_FAULT1[TSD]) that is saved during the shutdown event and can be read after the WAKEUP procedure. When a TSD fault occurs, the part immediately enters the SHUTDOWN state. Any pending transactions on UART or daisy chain are discarded. There is no fault signaling done when a thermal

shutdown event occurs, as the device immediately shuts down. The BQ79606A-Q1 does not exit SHUTDOWN automatically. To awaken the part, follow the normal WAKEUP procedure and make sure the ambient temperature is below thermal  $T_{SD\_FALL}$ . Once the die temperature falls below  $T_{SD\_FALL}$  and the WAKEUP command is received, the BQ79606A-Q1 follows the normal startup procedure. Upon waking up, the SYS\_FAULT1[TSD] bit is set and, if unmasked, a FAULT is indicated.

To warn the host of an impending thermal overload, the BQ79606A-Q1 includes an over-temperature warning that signals a fault when the die temperature approaches thermal shutdown. With every cell ADC conversion, the temperature read is compared against the thermal warning threshold ( $T_{warn}$ ). A fault is signaled when the read die temperature is greater than the threshold. When an unmasked temperature warning fault occurs, the SYS\_FAULT1[TWARN] bit is set. If unmasked, the NFAULT (base device) or FAULT\* interface (stack device) signals the fault. The application must utilize the thermal warning and die temperature ADC measurements to avoid thermal shutdown events.

#### NOTE

1. The uC should always monitor the ambient temperature of the system.
2. The uC should take appropriate actions to reduce the thermal rise if SYS\_FAULT1[TWARN] bit is set.
3. The uC should not wake the device if the ambient temperature is above  $T_{SD\_FALL}$ .

### 8.3.8 Oscillator Watchdogs

The oscillators used in the BQ79606A-Q1 are monitored by watchdog circuits. There are two oscillators in the device, the HFO and the LFO. If these oscillators are not functioning, the IC does not operate. If the HFO does not transition within  $t_{HFOWD}$  or the LFO does not transition within  $t_{LFOWD}$ , the watchdog circuits causes Digital Reset. It is recommended that the user sends a hardware shutdown command (using WAKEUP pin for a base device, or using the CONTROL1[SEND\_SHUTDOWN] command for stack devices from the next lower device). Then the user must follow the WAKEUP procedure to restart the devices. If the oscillators are truly damaged, the device will not restart and must be replaced.

In addition to the watchdog, the LFO frequency is monitored to ensure it stays within acceptable limits. If the LFO frequency falls outside of the  $f_{LFO\_CHECK}$  specification, the SYS\_FAULT3[LFO] bit is set.

### 8.3.9 Digital Reset

The BQ79606A-Q1 is in digital reset when one of the following conditions is satisfied:

1. When the DVDD is not valid and falls below  $V_{DRDVDD}$  threshold.
2. When  $V_{REF3}$ , used by  $V_{DRDVDD}$  monitor, is not valid.
3. When Internal bandgap voltage, used by POR circuits is not valid.
4. When one of the oscillator watchdogs is tripped.
5. When CONTROL[SOFT\_RESET]=1 command occurred.
6. For stack device, a wake up tone.
7. For base device, a WAKEUP pin hold low for  $t_{HLD\_WAKE}$  then released.

If the digital reset occurred due to DVDD, bandgap voltage, or  $V_{REF3}$ , recovering from digital reset requires all of these voltages to go above the under voltage threshold listed above.

## 8.4 Device Functional Modes

### 8.4.1 Power Modes

The BQ79606A-Q1 always operates in one of four modes. The mode depends on the stack voltage and the operational requirements of the system. A high level description of the modes is as follows:

1. POR - Pack voltage too low for functionality.
2. SHUTDOWN - Extremely low power operation. Limited functionality.
3. SLEEP - Low power operation. Some functionality available.

## Device Functional Modes (continued)

4. ACTIVE - Full power operation. All functionality available.

Figure 21 is a flow diagram of the transition between each of the modes. The modes are described in greater detail in the following sections.

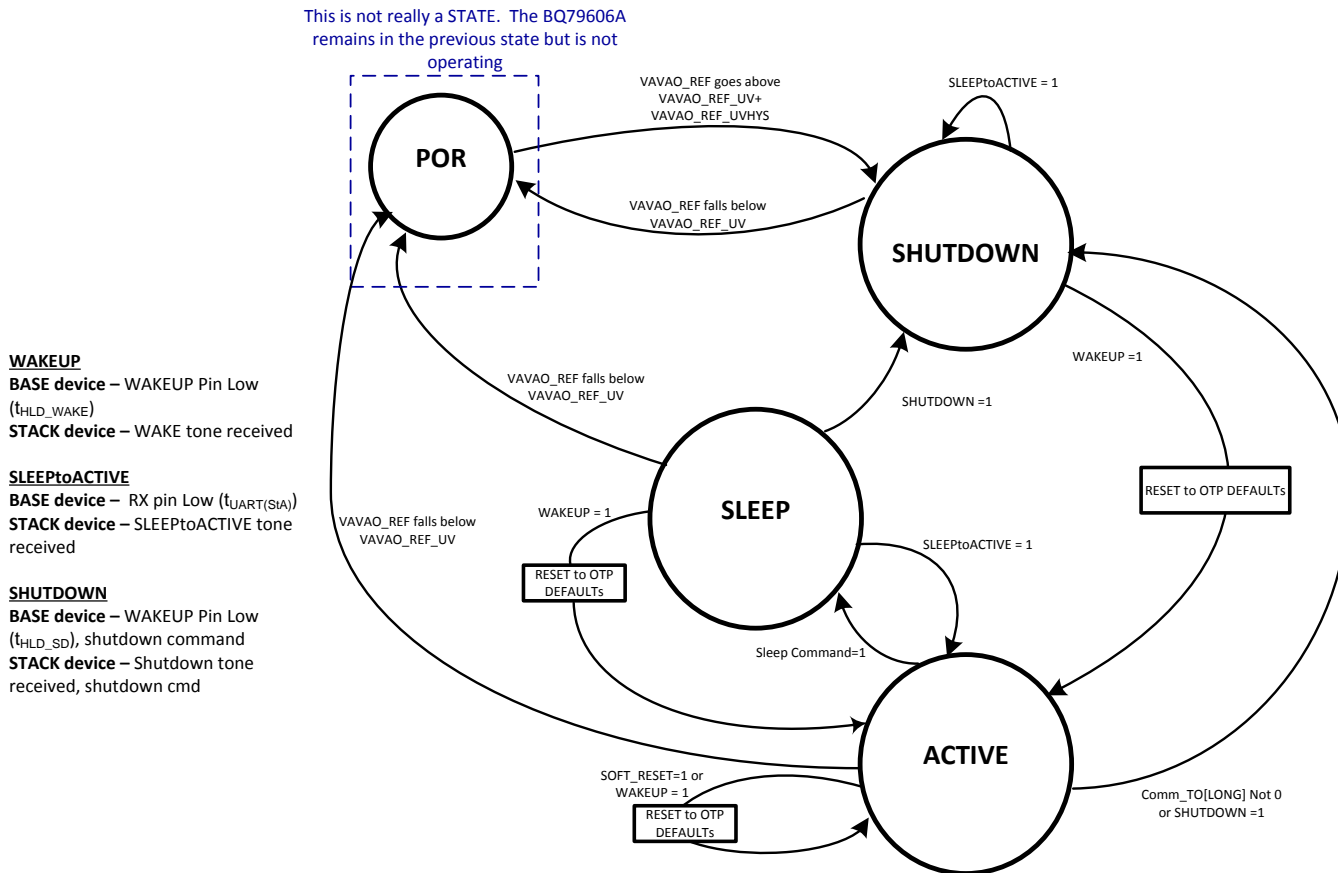

Figure 21. Power States Flow

### 8.4.1.1 POR (Power On Reset)

The BQ79606A-Q1 is in POR when AVAAO\_REF voltage falls below  $V_{AVAAO\_REF\_UV}$ . In POR, all of the circuits are shut down and held in RESET. When  $V_{AVAAO\_REF}$  rises above  $V_{UVLO\_REF\_UV} + V_{UVLO\_REF\_UVHYS}$ , the BQ79606A-Q1 transitions to SHUTDOWN mode. The SYS\_FAULT1[DRST] bit is set and is not cleared upon startup to signal to the host that a reset has occurred.

### 8.4.1.2 SHUTDOWN Mode

In SHUTDOWN mode, most of the circuits in the BQ79606A-Q1 are disabled. The functionality is limited in this mode and the quiescent current is very low as a result. While in SHUTDOWN, the BQ79606A-Q1 remains idle and strictly monitors the WAKEUP input (for a stand-alone or base/bridge device) for a low pulse or the COMx inputs (for stack devices) for a WAKE tone (*Stack Device Wakeup and Hardware Shutdown*). Once a WAKEUP signal or WAKE tone is received, the BQ79606A-Q1 transitions to ACTIVE mode. Table 6 specifies all of the circuits and functionality that are enabled or available in SHUTDOWN mode. Table 24 specifies the mode transition for SHUTDOWN mode response to the different tones for stack devices. Table 23 specifies the mode transition for SHUTDOWN mode response to the different signals for base devices. Additionally, the SYS\_FAULT1[DRST] bit is set and is not cleared upon startup to signal to the host that a reset has occurred.

### 8.4.1.3 SLEEP Mode

In SLEEP mode, the BQ79606A-Q1 has limited functionality. The functions are limited to :

## Device Functional Modes (continued)

- OV/UV and OT/UT Comparator
- Cell balancing
- SHUTDOWN Detection
- Fault Tone monitoring for the daisy chain interface (*Daisy-Chain FAULT\* Interface (Stack Devices)*)
- SLEEPtoACTIVE monitoring (signal on UART for base device or SLEEPtoACTIVE tone for stack device)
- WAKEUP (base device)/ WAKE tone (stack device) detection.
- GPIO FAULT
- NVM CRC

The comparators and Fault Tone monitoring must be enabled in ACTIVE mode before entering SLEEP mode. Once enabled, these functions remain active in SLEEP mode. If the functions are required to be disabled, the BQ79606A-Q1 must be commanded to ACTIVE mode to disable the functions.

While in SLEEP, the BQ79606A-Q1 monitors the WAKEUP input and the UART interface (for a stand-alone or base device) or the COMx inputs (for stack devices) for a WAKE or SLEEPtoACTIVE signal (*Stack Device Wakeup and Hardware Shutdown*). When a SLEEPtoACTIVE signal is received, either by UART interface or a SLEEPtoACTIVE tone on the daisy-chain, the BQ79606A-Q1 transitions to ACTIVE mode without resetting any internal settings. If a WAKEUP signal is received, either by the WAKEUP input or the WAKE tone on the daisy-chain, the BQ79606A-Q1 resets all of its settings to the system defaults and transitions to ACTIVE mode. [Table 6](#) specifies all of the circuits and functionality that are enabled or available in SLEEP mode. [Table 24](#) specifies the mode transition for SLEEP mode response to the different tones for stack devices. [Table 23](#) specifies the mode transition for SLEEP mode response to the different signals for base devices.

### 8.4.1.4 ACTIVE Mode

As the name suggests, ACTIVE mode enables the full functionality of the BQ79606A-Q1. All of the LDOs and references are enabled and the BQ79606A-Q1 is ready to do ADC conversions, cell balancing, and full communication to all of the devices in the daisy chain. Before enabling any of these functions, the host must wait for the BQ79606A-Q1 to fully start up. It takes approximately  $t_{SU(WAKE)}$  for the BQ79606A-Q1 to transition to ACTIVE mode and have full functionality available. Following a SOFT\_RESET, Digital Reset, or normal WAKEUP from SHUTDOWN, the host must clear the SYS\_FAULT1[DRST] bit (using the SYS\_FLT1\_RST[DRST\_RST] bit) to clear NFAULT and start the heartbeat (if enabled). ADVDD OSC fault may be also be triggered and must be cleared. [Table 6](#) specifies all of the functionality that are enabled or available in ACTIVE mode.

The flow diagram ([Figure 21](#)) indicates several different ACTIVE states. These are not actual states, but correspond to the possible actions done while in ACTIVE. These correspond with the specifications in the Electrical Characteristics table that are split into these items:

1.  $I_{ACT(IDLE)}$  specifies the current while in ACTIVE mode, but not doing any cell-balancing, ADC conversions, or communication. This is the baseline quiescent current in ACTIVE mode.
2.  $I_{ACT(BAL)}$  specifies the additional quiescent current during cell balancing.
3.  $I_{ACT(CONVERT)}$  specifies the additional quiescent current during ADC conversions.
4.  $I_{ACT(COMC)}$  and  $I_{ACT(COMT)}$  specifies the additional quiescent current during ADC communication.

During ACTIVE mode, if a WAKEUP command (either WAKEUP toggle on base device or WAKE tone on stack device) is received, the BQ79606A-Q1 resets to the system default values and forwards it to the next device and sets the SYS\_FAULT1[DRST] bit to signal to the host that a reset has occurred. If a SLEEPtoACTIVE command is received, the BQ79606A-Q1 forwards it up the stack and continues operating with no changes.

The BQ79606A-Q1 exits ACTIVE mode and enters SLEEP mode if the SLEEP command is set (CONTROL1[GOTO\_SLEEP]). The BQ79606A-Q1 exits ACTIVE mode and enters SHUTDOWN mode if no valid communication frames are received for the time set in the register (COMM\_TO[LONG]) if enabled. Additionally, the IC enters SHUTDOWN mode if a thermal shutdown event occurs, or if the SHUTDOWN command is set (CONTROL1[GOTO\_SHUTDOWN]). [Table 24](#) specifies the mode transition for ACTIVE mode response to the different tones for stack devices. [Table 23](#) specifies the mode transition for ACTIVE mode response to the different signals for base devices.



**Device Functional Modes (continued)**
**Table 6. Available Functions by Power Mode**

	SHUTDOWN	SLEEP	ACTIVE
OV/UV Comparators		X	X
OT/UT Comparators		X	X
Communications			X
Cell Balancing		X	X
WAKE Tone	X	X	X
WAKEUP Detection	X	X	X
SLEEPtoACTIVE Detection		X	X
SHUTDOWN Detection		X	X
ADC Reads			X
FAULTDET Tone		X	X
GPIO FAULT		X	X
SPI Master			X
Communication Timeout			X

## 8.5 Communication, Programming, GPIO, and Safety

### 8.5.1 Communication Interfaces and Programming

The BQ79606A-Q1 operates as a stand alone device or as a stack of up to 64 devices (1 base device and 63 stack devices) to monitor large stacks of Li-Ion cells. In a stack configuration, the single host, such as a microcontroller, communicates with a single "base" device to interface with the entire stack. The BQ79606A-Q1 integrates a daisy chain interface to allow all devices to communicate with the base device. The base device interfaces with the host through a UART communication interface and a fault signaling output (NFAULT). In stand-alone operation, the daisy-chain communication is disabled and the host communicates only with the single device.

#### 8.5.1.1 UART Communication Physical Layer

The BQ79606A-Q1 utilizes a UART interface to enable communication with a single host to one or more BQ79606A-Q1 devices. The factory OTP reset baud rate is set to 1Mbps as in the COMM\_CTRL register.

##### 8.5.1.1.1 UART Interface

The UART interface follows the standard serial protocol of 8-N-1 (see [Figure 22](#)), where it sends information as a START bit, followed by eight data bits, and then one STOP bit. The STOP bit indicates the end of the byte. If a byte is received that does not have the STOP bit set, the COMM\_UART\_FAULT[STOP] bit is set, indicating there may be a baud rate issue between the host and the device. In all, 10 bits comprise a character time. Received data bits are over-sampled by 16 times to improve communication reliability.

The UART sends data on the TX pin and receives data on the RX pin. When idle, the TX and RX are high. The UART interface requires that RX are pulled-up to VIO through a 10KΩ to 100-KΩ resistor. Do not leave RX unconnected. Ensure RX is connected directly to VIO for stack devices. The TX must be pulled high on the host-side on base/bridge devices to prevent triggering an invalid communications frame when the communication cable is not attached, or during power-off or the shutdown state when TX is high impedance. TX is always pulled to VIO internally while in ACTIVE or SLEEP mode, whether enabled or disabled. Leave TX unconnected if not used in stack devices. When using a serial cable to connect to the host controller, connect the TX pullup on the host side and the RX pullup on the BQ79606A-Q1 side.

The UART interface is strictly a half-duplex interface. While transmitting, any attempted communication on RX is ignored. The only exceptions are COMM CLEAR and COMM RESET. Receiving one of these commands immediately terminates the communication and performs the required action. See [Communication Clear \(Break\) Detection](#) and [Communication Reset Detection](#) for more details.

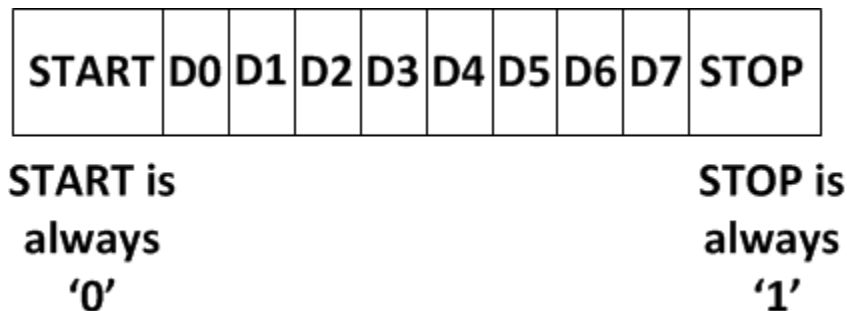

**Figure 22. UART Protocol**

##### 8.5.1.1.1.1 UART Transmitter

The transmitter is configurable to wait a specified number of bit periods after the last bit reception before starting transmission using the TX\_HOLD\_OFF register. This provides time for the host to switch the bus direction at the end of its transmission. The TX hold off time for base and stack can be calculated as below:

1. Generic formulas to calculate the actual TX hold (bit period) of time for STACK devices:
  1. Minimum=TX\_HOLD\_OFF x Bit Period
  2. Typical= 22.5+7x(Number of Devices-2)+(TX\_HOLD\_OFF+1.5) x Bit Period
  3. Maximum= 24.5+9x(Number of Devices-2)+(TX\_HOLD\_OFF+4.5) x Bit Period



## Communication, Programming, GPIO, and Safety (continued)

2. Generic formulas to calculate the actual TX hold (bit period) of time for BASE devices:
  1. Minimum=TX\_HOLD\_OFF x Bit Period
  2. Typical= 1.5+(TX\_HOLD\_OFF+1.5) x Bit Period
  3. Maximum= 2.5+(TX\_HOLD\_OFF+2.5) x Bit Period

Note that the total number of devices includes all stack devices and the base. Also note that the Bit Period depends on the baud rate.

When the device receives a communications reset, the baud rate for the UART is reset to 250kbps. The baud rate is programmable by the host to a higher or lower rate by writing to COMM\_CTRL[BAUD]. The UART TX is disabled/enabled using the COMM\_CTRL[UARTTX\_EN]. Once disabled, no responses are transmitted. The transmitter is disabled immediately following the disable command.

### 8.5.1.1.2 UART Receiver

The UART interface design works in half-duplex. While the device is transmitting data on TX, RX is ignored except when receiving a Communication Clear or Communication Reset. To avoid collisions during data transmission up the daisy-chain interface, the host microcontroller must wait until all bytes of a transmission are received from the device before attempting additional communication. If the microcontroller starts a transaction without waiting to receive the preceding transaction's response, the communication is not considered reliable and the microcontroller must send a Communication Clear (see Communication Clear (Break) Detection) or Communication Reset (see Communication Reset Detection) to restore normal communications to the base device. Breaks and communication resets are not sent to the stack devices. A Communication Clear or Communication Reset can be sent at any time. RX cannot be disabled, and is active even when the transmitter (TX) is disabled (COMM\_CTRL[TX\_EN] = 0).

### 8.5.1.1.3 UART Baud Rate Selection

The baud rate of the communications channel to the host is selectable between 125k-250k-500k-1Mbps baud rates. The default rate after a communications reset is 250kMbps. The default rate after a Digital Reset is the rate selected by the value stored in OTP for the COMM\_CTRL[BAUD] bits. When a new baud rate is selected, the new rate takes effect after the complete reception of a valid frame containing the new setting including the CRC. The next frame is sent at the new baud rate and all further frames are transmitted at the new rate. It is possible to change the baud rate at any time. After changing the baud rate, wait a minimum of 10µs before sending the first frame at the new baud rate. The value in the COMM\_CTRL[BAUD] affects the baud rate used in microcontroller communications on the TX and RX pins and the response baud rate of the daisy chain. The current baud rate setting for the device is read in the COMM\_STAT[BAUD\_STAT] bits. This reflects the actual baud rate used whether it be set by COMM\_CTRL[BAUD] or to hardware default (after communications reset).

**Table 7. UART BAUD COMM\_CTRL[BAUD] Setting**

COMM_CTRL[BAUD] Setting	BAUD Rate
00	125Kbps
01	250Kbps
10	500Kbps
11	1000Kbps

### 8.5.1.1.4 Communication Clear (Break) Detection

Use the Communication Clear command to clear the receiver and instruct it to look for a new start of frame. The next byte following the Break is considered a "start of frame" byte. The receiver continuously monitors the RX line for break condition. A communication clear is detected when the RX line is held low for a least a min value of  $t_{UART(BRK)}$  bit periods. Ensure that the break does not exceed the max value of  $t_{UART(BRK)}$  bit periods, as this may result in recognition of a SLEEPtoACTIVE and/or communication reset (if RX held low long enough to satisfy  $t_{UART(RST)}$ ). When detected, a communication clear sets the COMM\_UART\_FAULT[COMMCLR\_DET] flag. The host must wait at least  $t_{UART(RXMIN)}$  after the communication clear to start sending the frame. It should be noted that in addition to the COMM\_UART\_FAULT[COMMCLR\_DET] flag, the COMM\_UART\_FAULT[STOP] flag is also set because the communication clear timing violates the typical byte timing and the STOP bit is seen as '0'.

While using the daisy-chain configuration (CONFIG[MULTIDROP\_EN] = 0), if a communication clear is received (Base or Bridge) while waiting to respond to a read command, the device response is discarded and the COMM\_UART\_TR\_FAULT[WAIT] or COMM\_UART\_TR\_FAULT[SOF] bit is set (depending on the timing of receiving the communication clear). The stack devices do NOT see the communication clear and continue to send their responses which are forwarded to the host. In the stack configuration, the host should avoid this condition by waiting until all responses are received from the stack before sending a communication clear. Failure to do so results in the host receiving unexpected response frames.

When using the multi-drop configuration (CONFIG[MULTIDROP\_EN] = 1), a communication clear must be used before every frame to ensure consistent communication. If a communication clear is received during a response, or while waiting to respond, the responses are immediately discarded (if waiting to transmit) or stopped (if currently transmitting) and the COMM\_UART\_TR\_FAULT[WAIT] bit is set.

Note that for a device in sleep mode, sleep to active causes only communication clear detect COMM\_UART\_FAULT[COMMCLR\_DET], but no COMM\_UART\_FAULT[STOP]. For a device in active mode, sleep to active causes both communication clear detect and STOP

#### 8.5.1.1.5 Communication Reset Detection

A Communication Reset command is sent by holding the RX line low of the base device for  $t_{\text{UART}(RST)}$ . The primary purpose of sending a communications reset is to recover the device in the event the baud rate is inadvertently changed or unknown. The baud rate of the base device resets to 250Kbps regardless of the value stored in the COMM\_CTRL[BAUD] register. This sets the baud rate to a known, fixed rate (250Kbps), and the COMM\_UART\_FAULT[COMMRST\_DET] bit is set. The baud rate register COMM\_CTRL[BAUD] will not be affected by communication reset. This communication reset does not affect the stack devices (only the base will reset to 250Kbps). Writing to stack devices with an 1Mbps or 500Kbps baud rate should not be an issue. Therefore even if a stack device is set to 1Mbps baud, and base is reset to 250Kbps baud, the host can write to a stack device using 250Kbps. Only for read from stack the baud rate of stack device matters and then it must meet the baud of base and host. Therefore in this case, the host can still do a broadcast write at 250Kbps to set entire stack and base whatever new baud it wants them to be at.

Holding the RX line of the base device low for more than  $t_{\text{UART}(RST)}$  will also cause the base to send Sleep to active tones and Communications clear (break). The sleep to active and communication clear are inclusive in the communication reset.

In a case a communication reset is received while waiting to respond to a broadcast read or stack read command, the device response is discarded and the COMM\_UART\_TR\_FAULT[WAIT] bit is set. The stack devices do NOT see the reset and continue to send their responses which are forwarded to the host. In the stack configuration, the host should avoid this condition by waiting until all responses are received from the stack before sending a reset. Failure to do so results in the host receiving unexpected response frames. Note that performing a reset in the middle of receiving responses may result in buffer overflow errors if the baud rate for the base device is reset to a lower rate than the stack devices. It should be noted that in addition to the COMM\_UART\_FAULT[COMMRST\_DET] flag, the COMM\_UART\_FAULT[STOP] flag is also set because the reset timing violates the typical byte timing and the STOP bit is seen as '0'.

#### 8.5.1.2 Command and Response Protocol Layer

The host initiates every transaction between the host and the BQ79606A-Q1. The BQ79606A-Q1 never transmits data without first receiving a command frame from the host. After a command frame is transmitted, the initiator must wait for all expected responses to be returned (or a timeout in case of error) before initiating a new command frame. There are multiple types of commands:

1. Single Device Read – This command is used to read a register(s) from a single device in the stack or base/bridge devices.
2. Single Device Write – This command is used to write a register(s) to a single device in the stack or base/bridge devices.
3. Stack Read – This command is used to read a register(s) from the stack devices only. The CONFIG[STACK\_DEV] bit is used to configure a device as a stack device. The IC must be configured as a stack device (CONFIG[STACK\_DEV] = 1) to respond to Stack Read commands.
4. Stack Write – This command is used to write a register(s) for only the stack devices. The CONFIG[STACK\_DEV] bit is used to configure a device as a stack device. The IC must be configured as a stack device (CONFIG[STACK\_DEV] = 1) to respond to Stack Write commands.

5. Broadcast Read – This command is used to read a register(s) for all of the devices in the stack (including base and bridge devices).
6. Broadcast Write – This command is used to write a register(s) for all of the devices in the stack (including base and bridge devices).
7. Broadcast Write Reverse Direction – This command is used to send a broadcast write in the reverse direction from the direction selected using the CONTROL1[DIR\_SEL] bit. This command is intended to be used for switching the communication direction for the stack interface.

Host generated     Slave generated

Command Frame

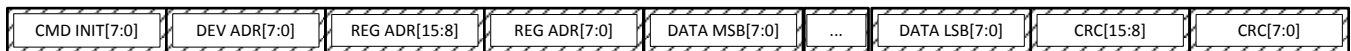

Response Frame

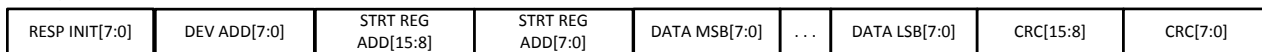

**(B) Single Device Read**

**Figure 23. Example Command and Response Frames**

**NOTE**

A response frame is not mandatory as part of the protocol. A response frame is only received from a read command frame.

**8.5.1.2.1 Transaction Frame Description**

The protocol layer is made up of transaction frames. There are two basic types of transaction frames; Command Frames (transactions from Host) and Response Frames (transactions from Slave). The transaction frames are made up of the following five field types:

- Frame Initialization
- Device Address ID
- Register Address
- Data
- Cyclic Redundancy Check (CRC).

The following sections detail the field types.

**8.5.1.2.1.1 Frame Initialization Byte**

The Frame Initialization Byte is used in both Command and Response Frames. It is always the first byte of the frame. The Frame Initialization Bytes performs two functions. First, it defines the frame as either a Command Frame (host) or a Response Frame (slave). Second, it defines the length of the frame that follows after the Frame Initialization Byte. This provides the receiver an exact number of bytes to expect for a complete command/response. If the transmission does not complete the correct number of bytes before the timeout occurs, an communication time out is generated if enabled. The Frame Initialization Byte for both the Command and Response frame is defined in [Table 8](#).

**Table 8. Command Frame Initialization Byte Definition**

Bit	Name	Description		
7	Frame_Type	1: Defines Command Frame		
6	REQ_TYPE	000: Single Device Read		
5		001: Single Device Write		
4		010: Stack Read		
		011: Stack Write		
3	Reserved	100: Broadcast Read		
		101: Broadcast Write		
		110: Broadcast Write Reverse Direction (use when changing the daisy chain communication direction)		
		111: Reserved. Any writes with this bit selection perform no function and sets COMM_COML_RC_FAULT[IERR], COMM_COMH_RC_FAULT[IERR], COMM_UART_RC_FAULT[IERR] (depending on which interface receives the fault).		
		2	DATA_SIZE	Reserved. Any write received to this bit is ignored.
		1		Number of bytes of data to be sent, not including the device address, register address, or CRC byte(s)
0	000: 1 bytes			
	001: 2 byte			
	010: 3 bytes			
	011: 4 bytes			
		100: 5 bytes		
		101: 6 bytes		
		110: 7 bytes		
		111: 8 bytes		

**Table 9. Response Frame Initialization Byte Definition**

Bit	Name	Description
7	Frame_Type	0: Defines Response Frame
6	RESPONSE_BYTES	0b0000000 - 0b1111111: Defines the number of data bytes contained in the response frame minus 1. For example, if 6 bytes are contained in the response frame, the RESPONSE_BYTES = 0b0000101
5		
4		
3		
2		
1		
0		

#### 8.5.1.2.1.2 Device Address Byte

The Device Address Byte identifies the device targeted by the command. This byte is omitted for Broadcast, Stack, and Broadcast Reverse Direction command frames. The devices that contain a matching value in their Device Address Status register (DEV\_ADD\_STAT[ADD]) may respond to the command and cause collision.

**Table 10. Device Address Byte Definition**

Bit	Name	Description
7	Reserved	Reserved. Any write received to this bit is ignored. Always write a '0'.
6	Reserved	Reserved. Any write received to this bit is ignored. Always write a '0'.
5	Device Address	0b000000 - 0b111111: Device Address of the device(s) intended for communication.
4		
3		
2		
1		
0		

### 8.5.1.2.1.3 Register Address Bytes

Register addresses are two bytes in length. Any write command done to an invalid register address is ignored. Any read from an invalid register returns a 0x00 response. This is true for command frames sent to an individual register with invalid address, or as part of command sent to multiple registers with invalid addresses. When read/write addresses a block of registers with only some invalid addresses, the valid addresses respond as normal, while the invalid addresses respond as previously described.

**Table 11. Register Address Byte Definition**

Bit	Name	Description
7	Register Address(MSB)	0b00000000 - 0b11111111: Targeted Register Address (MSB)
6		
5		
4		
3		
2		
1		
0		
7	Register Address(LSB)	0b00000000 - 0b11111111: Targeted Register Address (LSB)
6		
5		
4		
3		
2		
1		
0		

### 8.5.1.2.1.4 Data Byte(s)

The number of data bytes and the relevant information they convey is determined by the data size of command frame sent and the target register specified in that command frame. When part of a Command Frame, the data bytes contain the values to be written to the registers. When part of a Response Frame, the data bytes contain the values returned from the registers.

**Table 12. Data Byte(s) Definition**

Bit	Name	Description
7	Data Byte [0]	0b00000000 - 0b11111111: Data Byte
6		
5		
4		
3		
2		
1		
0		
...	...	...
7	Data Byte [n]	0b00000000 - 0b11111111: Data Byte
6		
5		
4		
3		
2		
1		
0		

Read command frames (single device read, stack read, and broadcast read) always contain a single data byte that indicates how many registers to read from the starting address. The BQ79606A-Q1 support up to 128 byte reads. The valid data byte for read command frame is 0b0000000 - 0b1111111. The MSB of the data byte is ignored for read command frames. For example, 0b10011001 is read as 0b0011001 and returns data from 26 registers.

**8.5.1.2.1.5 CRC Bytes**

The BQ79606A-Q1 uses a CRC (cyclic redundancy check) to protect data integrity during transmission. The CRC represents the remainder of a process analogous to polynomial long division, where the frame being checked is "divided" by the generator. The CRC appended to the frame is the "remainder". Because of this process, when the device receives a frame, the CRC calculated by the receiver across the entire frame including the transmitted CRC will be zero, indicating a correct transmission and reception. A non-zero result indicates a communication error. Specifically, the BQ79606A-Q1 uses the CRC-16-IBM polynomial ( $x^{16} + x^{15} + x^2 + 1$ ) with 0xFFFF initialization.

The CRC value is checked as the first step after receiving the communication frame. If the CRC is incorrect, the entire frame is discarded and not processed. Any additional frame errors are not checked and any errors are not indicated other than CRC error. The bytes are still transferred up/down the stack, thus every device that processed the frame will indicate a CRC error. This results in multiple devices indicating CRC faults on the same communication frame.

**8.5.1.2.1.5.1 Calculating Frame CRC Value**

The CRC calculation by the transmitter is in bit-stream order across the entire transmission frame (except for the CRC). When determining bit-stream order for implementing the CRC algorithm, it is important to note that protocol bytes transmit serially, least-significant bit first. Figure 24 illustrates the bit-stream order concept.

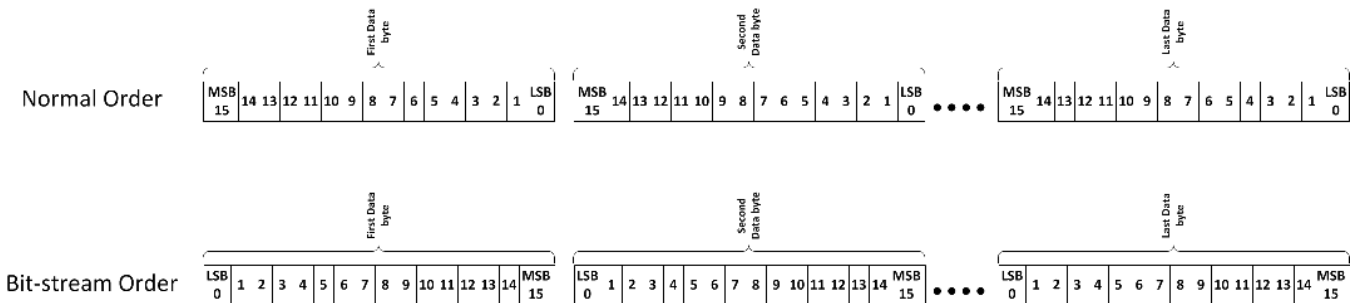

**Figure 24. Bit-Stream Order Explanation**

The CRC (0x0000) is appended to the end of the bit-stream. This bit-stream is then initialized by XOR'ing with 0xFFFF to catch any leading 0 errors. This new bit-stream is then divided by the polynomial (0xC002) until only the 2 byte CRC remains. During this process, the most significant 17-bits of the bit stream are XOR'd with the polynomial. The leading zero's of the result are removed and that result XOR'd with the polynomial once again. The process is repeated until only the 2 byte CRC remains. For example:

```

Command Frame = 0x80 00 02 0F 0B (0b1000 0000 0000 0000 0000 0010 0000 1111 0000 1011)
Command Frame in bit stream order = 0x01 00 40 F0 D0 (0b0000 0001 0000 0000 0100 0000 1111 0000 1101 0000)

After Initialization (XOR with 0xFFFF) = 0b1111 1110 1111 1111 0100 0000 1111 0000 1101 0000

1111 1110 1111 1111 0100 0000 1111 0000 1101 0000 0000 0000 0000 0000 #append 0x0000 for CRC
1100 0000 0000 0010 1 #XOR with polynomial
0011 1110 1111 1101 1100 0000 1111 0000 1101 0000 0000 0000 0000 0000

11 1110 1111 1101 1100 0000 1111 0000 1101 0000 0000 0000 0000 0000 #delete leading zeros from previous result
11 0000 0000 0000 101 #XOR with polynomial
00 1110 1111 1101 0110 0000 1111 0000 1101 0000

....
....
....
1100 0110 0000 0001 0000 0000
1100 0000 0000 0010 1 #XOR with polynomial
0000 0110 0000 0011 1000 0000

110 0000 0011 1000 0000
110 0000 0000 0001 01 #XOR with polynomial
000 0000 0011 1001 0100

0000 0011 1001 0100 #CRC result in bit stream order
1100 0000 0010 1001 #final CRC result in normal order

CRC final 0xC029
  
```

**Figure 25. Example 1. CRC Calculation Using Polynomial Division**

#### 8.5.1.2.1.5.2 Verifying Frame CRC

There are several methods for checking the CRC of a frame. One method is to simply calculate the CRC for the transmitted command except the last two bytes (CRC bytes) using the method described in the previous section, and then compare that result with the transmitted CRC bytes. A more simple option is to run the entire transmission through the CRC algorithm. If the CRC is correct, the result is '0000'. In this case, the initial zero padding of the bit-stream with sixteen zeroes is not necessary. Using the previous result and running through the algorithm produces the following results:

```

Command Frame = 0x80 00 02 0F 0B (0b1000 0000 0000 0000 0000 0010 0000 1111 0000 1011)
CRC to Check = 0xC029
Command Frame w/ CRC in bit stream order = 0x80 00 02 0F 0B C0 29 (0b1000 0000 0000 0000 0000 0010 0000 1111 0000 1011 0000 0011 1001 0100)

After Initialization (XOR with 0xFFFF) = 0b0 1111 1110 1111 1111 0100 0000 1111 0000 1101 0000 0000 0011 1001 0100

1111 1110 1111 1111 0100 0000 1111 0000 1101 0000 0000 0011 1001 010 #delete leading zeros from previous result
1100 0000 0000 0010 1 #XOR with polynomial
0011 1110 1111 1101 1100 0000 1111 0000 1101 0000 0000 0011 1001 0100

11 1110 1111 1101 1100 0000 1111 0000 1101 0000 0000 0011 1001 0100 #delete leading zeros from previous result
11 0000 0000 0000 101 #XOR with polynomial
00 1110 1111 1101 0110 0000 1111 0000 1101 0000 0000 0011 1001 0100

....
....
....
1100 0110 0000 0010 1001 0100
1100 0000 0000 0010 1 #XOR with polynomial
0000 0110 0000 0000 0001 0100

1 1000 0000 0000 0101 00
1 1000 0000 0000 0101 #XOR with polynomial
0 0000 0000 0000 0000 00

0x0000 #verifies that CRC checks out valid
  
```

**Figure 26. CRC Verification Using Polynomial Division**



Note the result of '0b0000 0000 0000 0000' for the CRC, indicating a successful check.

#### 8.5.1.2.1.5.3 Communication CRC Diagnostics

To test the CRC check for the communication path is functionally, the CRC in response packets can be purposely set incorrectly. Use the DIAG\_CTRL1[FLIP\_TR\_CRC] bit to invert all bits of the CRC for response frames.

#### 8.5.1.2.2 Transaction Frame Examples

Transaction frames are created using the frames discussed in the previous sections. The following sections outline all of the ways transaction frames are created using the individual frames. The CRC values in the examples are correct and are used to verify the customer CRC algorithm. The CRC is verified by the device with every received command frame and the command is not executed unless the CRC is valid. Command Frames fall into two general categories:

1. Write command frames that do not generate any response frames
2. Read command frames that generate at least one response frame.

The REQ\_TYPE field in the Frame Initialization byte determines the category to which a command frame belongs. Category 1 contains the Single Device Write, Stack Write, Broadcast Reverse direction, and Broadcast Write request types. Category 2 contains the Single Device Read, Stack Write Read, and Broadcast Read. The number of response frames generated by the Category 2 command frames depends on the number of devices addressed by the command frame. In the case where more than one response frame is received in response to a single command frame, each response frame is a complete frame containing the Frame Initialization, Device address, Register address, Data, and CRC bytes. A single device does not respond with more than a single response frame in response to any single command frame. [Figure 27](#) illustrates all of the different command and response frames.

 Host generated     Slave generated

Command Frame



(A) Single Device Write

Command Frame



Response Frame

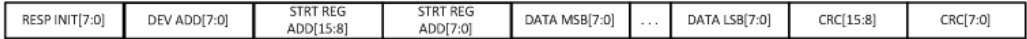

(B) Single Device Read

Command Frame

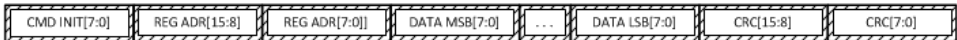

(C) Stack Write

Command Frame

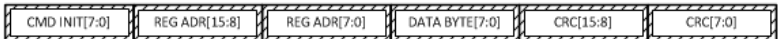

Response Frame

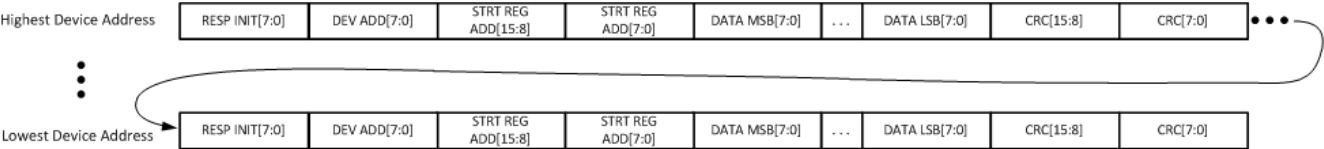

(D) Stack Read

Command Frame

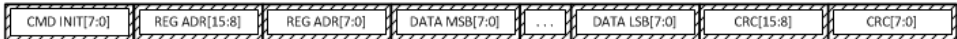

(E) Broadcast Write

Command Frame



Response Frame

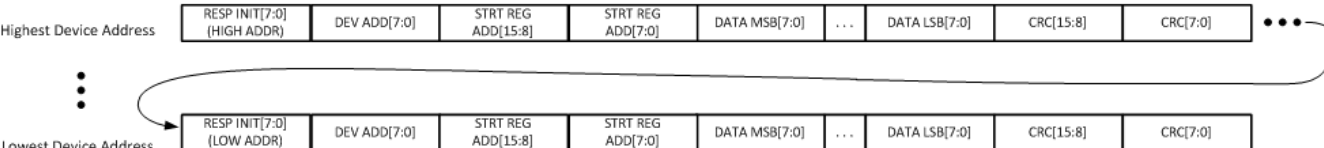

(F) Broadcast Read

Command Frame

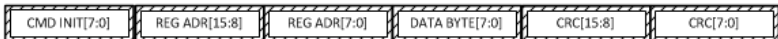

(G) Broadcast Write Reverse Direction

Figure 27. Transaction Frame Structures

### 8.5.1.2.2.1 Single Device Read Command Frame

A read command for a single device generates a response frame whose length depends on the requested number of register bytes read. For example, the cell voltage registers are grouped such that all of the cell voltages can be read with a single command frame. The single device read command frame must contain the register address to start at (address field) and the number of bytes to return (number of registers to read). The DATA\_SIZE field in the initialization byte for the single device read command is always be 0b000 as the maximum number of readable bytes is 128 (1 byte worth of addresses). The command frame for a burst read of all of the cell voltages is configured as in [Table 13](#).

**Table 13. Single Device Read Command Frame**

	Data	Comments
Initialization Byte	0x80	Always 0x80
Device ID Address	0x00	Device address 0 is addressed in this case.
Register Address	0x0215	Start with address 0x215 (VCELL1H)
Data	0x0B	Send 12bytes worth of data back (register contents from 0x215 to 0x220)
CRC	0xCB49	

### 8.5.1.2.2.2 Single Device Write Command Frame

A write command for a single device enables the customer to update up to 8 consecutive registers with one command. Some register writes, OTP\_PROG\_UNLOCK1\* and OTP\_PROG\_UNLOCK2\* for example, require that multiple registers be written with one command. The single device write command frame must contain the register address to start at (address field) and the data bytes to write to the registers. The DATA\_SIZE field in the initialization byte for the single device write command is the number of registers to update. The command frame for a single device write to the OTP\_PROG\_UNLOCK1\* registers is configured as in [Table 14](#) Initialization byte is 0x90 for 1 byte data read, 0x91 for 2 bytes data read, 0x92 for 3 bytes data read and so on.

**Table 14. Single Device Write Command Frame**

	Data	Comments
Initialization Byte	0x93	Writing 4 data bytes to a single device (0x90 for 1 bytes data read)
Device ID Address	0x00	Device address 0 is addressed in this case.
Register Address	0x0100	Start with address 0x100 (OTP_PROG_UNLOCK1A)
Data	0x02B778BC	Write 4 bytes to registers 0x100-0x103
CRC	0x9A8C	

### 8.5.1.2.2.3 Stack Read Command Frame

A read command for the stack devices (it does not include the base or bridge device) generates a number of response frames depending on the number of devices in the stack, whose length depends on the requested number of register bytes read. For example, using the same cell voltage register example as above, but now addressing a stack of 3 devices, the response to this command is 3 separate response frames, each with a length of 18 bytes (12 data bytes + 6 protocol bytes). The stack device read command frame must contain the register address to start at (address field) and the number of bytes to return (number of registers to read). The DATA\_SIZE field in the initialization byte for the read command is always 0b000 as the maximum number of readable bytes is 128 (1 byte worth of addresses). The command frame for a burst read of all of the cell voltages is configured as in [Table 15](#).

During the response, each device (address N) in the stack waits until the device above (address N+1) it responds before appending its message to the full response frame. The CRC is validated while receiving the responses. If a CRC error occurs in the response frame from address N+1, device N does NOT append its message and an invalid CRC fault is generated.

A stack read/ is the same as the broadcast read except that it applies only for stack devices (excludes the base and the bridge).

**Table 15. Stack Read Command Frame**

	Data	Comments
Initialization Byte	0xA0	Always 0xA0
Device ID Address	--	No address byte is sent in stack read
Register Address	0x0215	Start with address 0x215 (VCELL1H)
Data	0x0B	Send 12 bytes worth of data back (register contents from 0x215 to 0x220) from each device in the stack.
CRC	0xCCB3	

#### 8.5.1.2.2.4 Stack Write Command Frame

A write command for a stack devices (it does not include the base or bridge device) enables the customer to update up to 8 consecutive registers for an entire stack of devices with one command. As in the previous example, some register writes, OTP\_PROG\_UNLOCK1\* and OTP\_PROG\_UNLOCK2\* for example, require that multiple registers be written with one command. The stack write command frame must contain the register address to start at (address field) and the data bytes to write to the registers. The DATA\_SIZE field in the initialization frame for the single device write command is the number of registers to update. The command frame for a stack write to the OTP\_PROG\_UNLOCK1\* registers is configured as in [Table 16](#).

A stack write is the same as the broadcast write except that it applies only for stack devices (excludes the base and the bridge).

**Table 16. Stack Write Command Frame**

	Data	Comments
Initialization Byte	0xB3	Writing 4 bytes to the stack devices (B0 for 1 byte)
Device ID Address	--	No address byte is sent in stack write
Register Address	0x0100	Start with address 0x100 (OTP_PROG_UNLOCK1A)
Data	0x02B778BC	Write 4 bytes to registers 0x100-0x103 to all devices in stack
CRC	0x0A35	

#### 8.5.1.2.2.5 Broadcast Read Command Frame

A broadcast read command generates a number of response frames depending on the number of devices in the stack (plus the base and the bridge), whose length depends on the requested number of register bytes read. For example, using the same cell voltage register example as above, but now broadcasting to 20 devices, the response to this command is 20 separate response frames, each with a length of 18 bytes (12 data bytes + 6 protocol bytes). The broadcast read command frame must contain the register address to start at (address field) and the number of bytes to return (number of registers to read). The DATA\_SIZE field in the initialization frame for the broadcast read command is always 0b000 as the maximum number of readable bytes is 128 (1 byte worth of addresses). The command frame for a burst read of all of the cell voltages is configured as in [Table 17](#).

During the response, each device (address N) in the stack waits until the device above (address N+1) it responds before appending its message to the full response frame. The CRC is validated while receiving the responses. If a CRC error occurs in the response frame from address N+1, device N does NOT append its message and an invalid CRC fault is generated.

**Table 17. Broadcast Read Command Frame**

	Data	Comments
Initialization Byte	0xC0	Always 0xC0
Device ID Address	--	No address byte is sent in broadcast mode
Register Address	0x0215	Start with address 0x215 (VCELL1H)
Data	0x0B	Send 12bytes worth of data back (register contents from 0x215 to 0x220)
CRC	0xD2B3	

### 8.5.1.2.2.6 Broadcast Write Command Frame

A broadcast write command enables the customer to update up to 8 consecutive registers for an entire stack of devices (including the base and the bridge devices) with one command. As in the previous example, some register writes, OTP\_PROG\_UNLOCK1\* and OTP\_PROG\_UNLOCK2\* for example, require that multiple registers be written with one command. The broadcast write command frame must contain the register address to start at (address field) and the data bytes to write to the registers. The DATA\_SIZE field in the initialization frame for the single device write command is the number of registers to update. The command frame for a broadcast write to the OTP\_PROG\_UNLOCK1\* registers is configured as in [Table 18](#)

**Table 18. Broadcast Write Command Frame**

	Data	Comments
Initialization Byte	0xD3	Writing 4 bytes to the all devices (D0 for 1byte)
Device ID Address	--	No address byte is sent in broadcast mode
Register Address	0x0100	Start with address 0x100 (OTP_PROG_UNLOCK1A)
Data	0x02B778BC	Write 4 bytes to registers 0x100-0x103 to all devices
CRC	0x336A	

### 8.5.1.2.2.7 Broadcast Write Reverse Direction

A broadcast write reverse direction command enables the customer to switch the daisy chain communication direction for stack devices. The broadcast write reverse direction command is always the same as it is only used with the CONTROL1[DIR\_SEL] bit. The command frame for a broadcast write reverse direction is configured as in [Table 19](#).

**Table 19. Broadcast Write Reverse Direction Command Frame**

	Data	Comments
Initialization Byte	0xE0	Writing 1 byte in the reverse direction
Device ID Address	--	No address byte is sent in broadcast mode
Register Address	0x0105	Start with address 0x0105 (CONTROL1)
Data	0x80	Set the DIR_SEL bit to change stack communication to the 'south' direction.
CRC	0x64D4	

#### NOTE

The broadcast write reverse direction allows any write command to be sent in the reverse direction. It is not recommended to send any command other than the CONTROL1[DIR\_SEL] to avoid communication collisions. Communication collisions are not detected and result in corrupted communication on the stack interface.

### 8.5.1.2.2.8 Response Frame

Response frames are generated in response to read command frames. For multiple device command frames, stack reads and broadcast reads, the response is broken into individual response frames from each device addressed. The size of each response frame is limited to 128 bytes, but must be at least 1. The example in [Table 20](#) shows a response to a read command from device at address 5 for all cell voltages (as in the previous read examples).

**Table 20. Response Command Frame**

	Data	Comments
Initialization Byte	0x0B	Sending 12 bytes of data
Device ID Address	0x05	Device address 0x05
Register Address	0x0215	Starting address for response bytes is 0x215
Data	0xC124456FF43971202861681F	12 bytes of data requested (random numbers for this example)

**Table 20. Response Command Frame (continued)**

	Data	Comments
CRC	0xAC33	

### 8.5.1.3 Daisy Chain Communication

The daisy chain communication is created using differential signaling to minimize Electro-Magnetic Susceptibility (EMS) and Bulk Current Injection (BCI) immunity. The differential communication transmits true and complement data on the COM\*P and COM\*N pins respectively. In a multiple device stack, there are configurations where the BQ79606A-Q1 are physically located on the same board or located in entirely separate packs connected with twisted-pair wiring.

The BQ79606A-Q1 supports the use of transformers or capacitors to electrically isolate the signals between devices in the stack. For applications that have multiple devices on the same PCB, a single level-shifting capacitor is connected between the COM\* pins of the devices. For extremely noisy environments, additional filtering may be necessary. For devices that are separated by cabling, additional isolation components must be used. See [Daisy-Chain Differential Bus](#) for specific details on selecting components. The individual transmitters and receivers are enabled/disabled using the DAISY\_CHAIN\_CTRL register.

#### 8.5.1.3.1 Daisy Chain Transmitter and Receiver Functionality

The daisy chain is bi-directional and half duplex, and therefore, has a transmitter (TX) and receiver (RX) on both interfaces (COMH and COML). The TX and RX functions are controlled automatically by the hardware (under certain conditions, typically during startup and reset) and by the user (under other conditions). The DAISY\_CHAIN\_CTRL register provides user controls for the individual interfaces. The hardware control is determined by the startup conditions: if WAKEUP is high after startup, the COML TX and COML RX are disabled and upon wakeup from a hardware shutdown (only using the WAKEUP input), the COMH and COML receivers and the COML transmitter are disabled. More information on these conditions is outlined in the [Base Device Wakeup and Hardware Shutdown](#) section. Once startup has completed, use the CONTROL2[DAISY\_CHAIN\_CTRL\_EN] bit to select the user configurable settings in the DAISY\_CHAIN\_CTRL register. The DAISY\_CHAIN\_STAT register shows the current enable/disable status for both COMH and COML interfaces as well as the status of the control for the interfaces (Hardware vs. User). Note that after enabling COM RX, wait for at least 100usec before start communication.

**Table 21. COM RX Data and Tone Status**

RX Data/Tone		WAKEUP Pin = High	WAKEUP Pin = Low
COMH RX	Data	See Note 2	Controlled by DAISY_CHAIN_CTRL[COMHRX_EN] bit
	Tone (See Note 1)	See Note 2	Always Enabled
COML RX	Data	See Note 3	Controlled by DAISY_CHAIN_CTRL[COMLRX_EN] bit
	Tone (See Note 1)	See Note 3	Always Enabled

**Table 22. COM TX Data and Tone Status**

TX Data/Tone		WAKEUP Pin = High	WAKEUP Pin = Low
COMH TX	Data	Controlled by DAISY_CHAIN_CTRL[COMHTX_EN] bit	Controlled by DAISY_CHAIN_CTRL[COMHTX_EN] bit
	Tone (See Note 1)	Controlled by DAISY_CHAIN_CTRL[COMHTX_EN] bit	Controlled by DAISY_CHAIN_CTRL[COMHTX_EN] bit
COML TX	Data	See Note 4	Controlled by DAISY_CHAIN_CTRL[COMLTX_EN] bit
	Tone (See Note 1)	See Note 4	Controlled by DAISY_CHAIN_CTRL[COMLTX_EN] bit

### NOTE

1. The Tone includes Wake tone, SLEEPToActive tone, and Shutdown tone.
2. After startup or reset and the WAKEUP pin is High, the COMH RX data and tone are controlled by DAISY\_CHAIN\_CTRL[COMHRX\_EN] bit. However, if the device wakeup from a hardware shutdown only using the WAKEUP input, the COMH RX data and tone are disabled. Once the wake up is completed, the user can control the COMH RX through DAISY\_CHAIN\_CTRL[COMHRX\_EN] bit and by setting CONTROL2[DAISY\_CHAIN\_CTRL\_EN]=1.
3. After startup or reset and the WAKEUP pin is High, the COML RX data and tone are disabled. Once the startup and reset is completed, the user can control the COML RX through DAISY\_CHAIN\_CTRL[COMLRX\_EN] bit and by setting CONTROL2[DAISY\_CHAIN\_CTRL\_EN]=1.
4. After startup or reset and the WAKEUP pin is High, the COML TX data and tone are disabled. Once the startup and reset is completed, the user can control the COML TX through DAISY\_CHAIN\_CTRL[COMLTX\_EN] bit and by setting CONTROL2[DAISY\_CHAIN\_CTRL\_EN]=1.

#### 8.5.1.3.2 Daisy Chain Protocol Description

The differential stack interface uses an asynchronous 12-bit byte-transfer protocol that operates at  $\text{baud}_{\text{DC}}$ . Data is transferred LSB first and every bit is duplicated (with a complement) to ensure the transmission has no DC content. The receiver samples the signal 8 times per half bit time. A zero is transmitted as one half-bit period low followed by one half-bit period high, while transmission of a one is a half-bit period high followed by a half-bit period low. See [Figure 28A](#) for a graphical representation of the bit definitions. Two synchronization bits are used to extract timing information. If the timing information extracted from the demodulation of the preamble half-bit and the two full bits of synchronization is outside of the expected window, the COMM\_COM\*\_FAULT[SYNC2] bit is set and the byte is not processed. If the demodulation of the preamble half-bit and the two full bits of synchronization data have errors and the timing is likely not correct, the COMM\_COM\*\_FAULT[SYNC1] bit is set and the byte is not processed.

A byte contains two SYNC bits, a start-of-frame bit, eight data bits starting from the LSB "D0" to MSB "D7" (D0 is transmitted just after State-Of-Frame and D7 comes last before the Byte Error and Postamble), and byte error bit as shown in the figure below. Additionally, a preamble and postamble are always used to ensure DC balance for transformer applications. The SYNC bits are always two zeros. See [Figure 28B](#) for a graphical representation of the protocol. Once two valid SYNC bits are received, the additional bits are decoded and sent to the command processor. If, during the demodulation of the bus traffic, a bit is decoded that is not a "strong" '1' or '0' (meaning there were not sufficient samples to indicate the logic level with certainty), the COMM\_COM\*\_FAULT[BIT] bit is set and the byte is not decoded. If, during the demodulation of the bus traffic, one or more of the received data bits does not have the expected complement bit structure, the COMM\_COM\*\_FAULT[DATA\_ORDER] bit is set and the byte is not decoded. If, during the communication, there is a failure to detect a valid '1' or '0' on the bus when one is expected (every bit time), the COMM\_COM\*\_FAULT[DATA\_MISS] bit is set and the byte is not decoded.



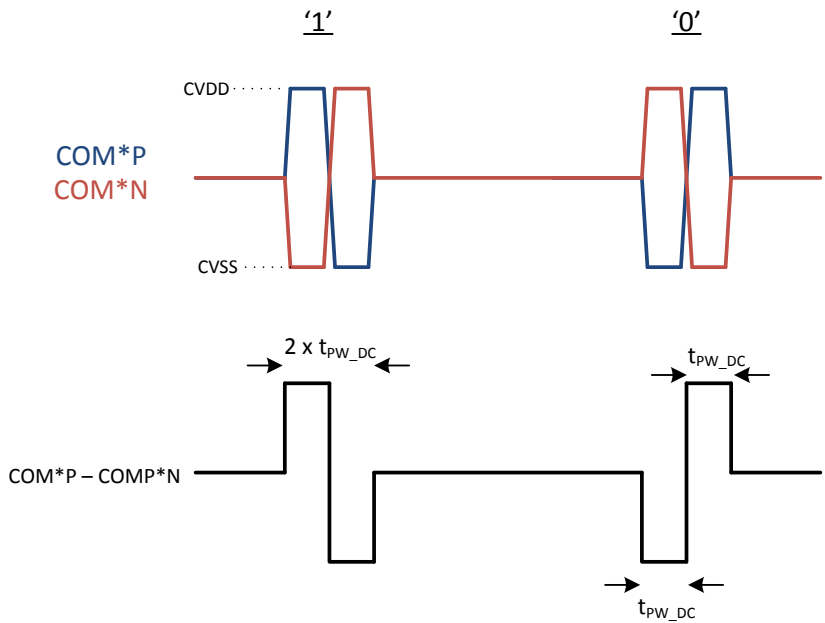

A. Bit Definitions

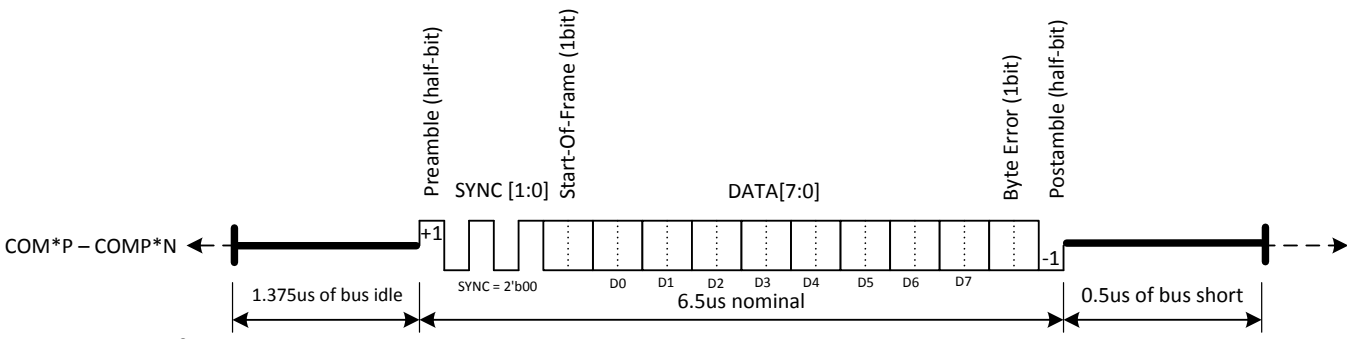

B. Byte Definition

Figure 28. Daisy Chain Protocol Structure

Each byte is transmitted at 2MHz (250ns per pulse or 500ns per couplet). The throughput is determined by the baud rate set by the COMM\_CTRL[BAUD] bits. The time between each byte depends on this setting, but the byte time is always the same. See Figure 29.

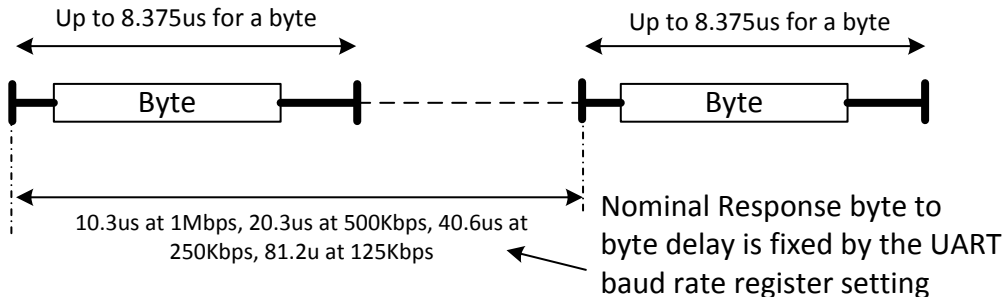

Figure 29. Byte Transfer Structure

The daisy chain retransmits the data on a bit level to improve daisy-chain robustness. If an error is detected in the received data (any error indicated in the COMM\_COM\*\_FAULT register), the data is still forwarded, but the byte error bit is set to indicate to the devices up the stack that the data is likely corrupted and must be ignored. The COMM\_COM\*\_FAULT[BERR] bit is set and the byte is ignored whenever a byte is received with the byte error set. The ignored byte likely also causes other errors as well depending on where in the frame it occurs.

The start-of-frame bit defines the byte as the first in the frame (the frame initialization byte). The first frame bit is analogous to receiving a communication clear (break) from the UART interface. Receiving a frame start bit in the middle of a frame causes the frame to be discarded, and a new frame started. The unexpected SOF flag (COMM\_COM\*\_\*\_FAULT[SOF]) is set. For situations where sync in the datastream is lost, the start frame bit enables re-syncing the datastream. The frame start bit is set whenever a communication clear is signaled on the UART interface (also it is set based on the framing event).

Data is forwarded up/down the stack and to the host (from the base device) even if the byte is tagged with a byte error. Each device recognizes the byte error and sets the appropriate BERR bit (register depends on the interface and what kind of frame is received) and then signals a fault (if unmasked). The host must rely on CRC errors and the BERR fault to determine that a byte error has occurred and take the appropriate action.

### 8.5.1.3.3 Ring Architecture

The daisy chain communication for the BQ79606A-Q1 utilizes a "ring" architecture. In this architecture, a break between two modules does not prevent communication to all upstream devices as in a normal non-ring scheme. When the host detects a communication break, the BQ79606A-Q1 allows the host to switch the communication direction to communicate with devices on both side of the break. This allows for safe operation until the break in the lines is repaired.

Once the host determines there is a break in the daisy-chain (there is no response received during a predetermined timeout and after multiple tries) the host follows the following procedure. The following procedures assume the initial transmit direction was set to North (COML to COMH) CONTROL1[DIR\_SEL]=0.

1. For the base device: Disable daisy chain high COM RX and COM TX by writing DAISY\_CHAIN\_CTRL[COMHRX\_EN]=0 and DAISY\_CHAIN\_CTRL [COMHTX\_EN]=0.
2. For the base device: Enable daisy chain Low COM RX and COM TX by writing DAISY\_CHAIN\_CTRL[COMLRX\_EN]=1 and DAISY\_CHAIN\_CTRL [COMLTX\_EN]=1.
3. For the base device: Write 1 to DAISY\_CHAIN\_CTRL\_EN in CONTROL2 register to ensure the COMH/COML TX/RX function is controlled by DAISY\_CHAIN\_CTRL register.
4. For the base device: Write 1 to CONTROL1[DIR\_SEL] to reverse the direction of the base and the next subsequent commands go to low side.
5. Send Broadcast Write Reverse Direction Command Frame to all devices to switch their direction.
6. Send a Broadcast command to clear the CONFIG register of all devices to ensure earlier setting is cleared and the CONFIG[TOP\_STACK] is cleared.
7. Perform auto addressing by sending a broadcast command to set CONTROL1[ADD\_WRITE\_EN]=1 (to enable addressing) and ensure the CONTROL1[DIR\_SEL]=1.
8. Broadcast address of each device using DEVADD\_USR register.
9. Set the first device as a base by writing 0 to CONFIG[STACK\_DEV] of the top device.
10. Set as stack the other devices by writing 1 to CONFIG[STACK\_DEV] of the top device.
11. Set Top of Stack to the top device by writing 1 to CONFIG[TOP\_STACK] of the top device.

These devices accept commands from the north direction and forward them in the south direction. Responses are sent on north bus and received on the south bus. The host repeats the process to communicate with the devices in the segment below the communication line break.

---

#### NOTE

Reverse direction in Ring Architecture after power up requires the host first to do normal direction auto addressing. At power up, all the devices are addressed as 0 by default, and the first step above can result in disabling all devices RX's and TX's. Normal auto addressing prevent this from happening.

---

Devices in the stack do NOT transmit commands in both the north and south directions simultaneously. The commands are, however, received from both directions. This is to enable the switching of the bus direction. If a command is received on the non-selected receiver, and the command frame initialization byte does NOT identify the frame as a Broadcast Write Reverse Direction command, the command is ignored. If, at any time, commands are received on both buses, only the bus programmed by the CONTROL1[DIR\_SEL] bit is executed and the other is discarded. The default direction for the stack communication bus is north.

If the user must switch off all devices' COMHTX and COMLTX using COMHTX\_EN and COMLTX\_EN then it has to be handled by doing individual write to DAISY\_CHAIN\_CTRL register, one by one starting from top most device instead of attempting a broadcast write.

#### 8.5.1.3.4 Communication Diagnostics

The BQ79606A-Q1 provides comprehensive debugging information for the communication interface. Each communication interface (UART, COML, and COMH) has fault registers to assist with debug during development. The COMM\_\*\_FAULT registers indicate faults that occur at the interface level. Faults indicated here inform the host that the data received is likely wrong and should not be trusted. The COMM\_\*\_RR\_FAULT registers indicate faults that occur while receiving a response frame. The COMM\_\*\_RC\_FAULT registers indicate faults that occur while receiving a command frame. The COMM\_\*\_TR\_FAULT registers indicate faults that occur while transmitting. Additionally, the TONE\_FAULT register indicates faults related to the FAULT interface. See the individual register description for specifics on the individual fault conditions. Frame counters are provided for transmitted, received, and discarded frames for each bus.

##### 8.5.1.3.4.1 Byte Errors

General byte errors (COMM\_\*\_R\*\_FAULT[BERR]) and initialization byte errors (COMM\_\*\_RC\_FAULT[IERR]) are the result of improper formatting of a byte. When these occur, the assumption is that the frame timing is incorrect and the information must not be used. Therefore, when a general byte error occurs, all bytes that follow are ignored until a communication break (for UART interface) or start-of-frame bit set (daisy chain interface) is received. As a result, these errors utilize special handling and must be cleared using a communication clear or reset.

COMM\_COM\*\_R\*\_FAULT[BERR] is set when a byte error occurs on any byte in a frame received on the COMH/COML interface. The COMM\_UART\_R\*\_FAULT[BERR] bit is set when a STOP error occurs on any byte received on the UART interface that is not directly followed by a communication clear. When the byte error occurs, all further bytes received on that interface are ignored. Bytes received on COMH/COML are propagated up the stack, while bytes received on the UART are not propagated. Any other frame errors that occur while the bytes are ignored are not realized or indicated as they are ignored. This includes CRC errors. The bytes are ignored until a SOF byte (COMH/COML) or communication clear (UART interface) is received.

The COMM\_COM\*\_RC\_FAULT[IERR] bit is set when a frame initialization byte is expected, but the SOF bit of the received byte is not set or an invalid frame type (one of the reserved commands) is selected. The COMM\_UART\_RC\_FAULT[IERR] bit is set when the frame initialization byte has a stop error, reserved command bits set, or is configured as a response frame (not in multidrop mode). Frame initialization bytes for UART are the 1st byte after a break, or based on frame sequence. When in the multidrop configuration, IERR is also set when the first frame received after a break is a response frame. Bytes received on COMH/COML are propagated up the stack so it is likely all devices in the stack will indicate the IERR fault, bytes received on the UART are not propagated. Any other frame errors that occur while the bytes are ignored are not realized or indicated as they are ignored. This includes CRC errors. The bytes are ignored until a SOF byte (COMH/COML) or communication clear (UART interface) is received.

##### 8.5.1.3.4.2 Frame Counters

The COMM\_\*\_TR\_STAT1/COMM\_\*\_TR\_STAT2, COMM\_\*\_RR\_STAT1/COMM\_\*\_RR\_STAT2, COMM\_\*\_RC\_STAT1/COMM\_\*\_RC\_STAT2 are 16-bit counters that track the number of valid frames received or transmitted. The COMM\_\*\_RR\_STAT3 and COMM\_\*\_RC\_STAT3 are 8-bit counters that track the number frames that have been discarded for some reason. All counters saturate and do not roll-over. To ensure that all counter data refers to the same period of time, the counters values are latched into registers and the counters are reset upon the user reading the key register. Reading the COMM\_UART\_RC\_STAT3 register latches all of

the `COMM_UART_*_STAT*` register values and resets all of the UART counters. Reading the `COMM_COML_RC_STAT3` register latches all of the `COMM_COML_*_STAT*` register values and resets all of the COML counters. Reading the `COMM_COMH_RR_STAT3` register latches all of the `COMM_COMH_*_STAT*` register values and resets all of the COMH counters. Each successive read to the key register updates the registers with the current counter value and resets the counters.

The `COMM_COM*_TR_STAT1/COMM_COM*_TR_STAT2` counter is incremented whenever a response frame is generated and transmitted over the interface. This does not increment for forwarded response frames (for daisy chain interface), the frame must be generated by the device.

The `COMM_*_RR_STAT1/COMM_*_RR_STAT2` counter is incremented whenever a valid (an error free) response frame is received over the interface. Response frames received over the daisy-chain DO increment this counter as they are received and validated during broadcast or stack reads. The counter does NOT increment for individual device responses that are forwarded.

The `COMM_*_RC_STAT1/COMM_*_RC_STAT2` counter is incremented whenever a valid (an error free) command frame is received over the interface.

The `COMM_*_RR_STAT3` counter is incremented when a received response frame is discarded due to a fault. The discard reason is set in the fault registers when the actual discard event occurs. See the [Byte Errors](#) for details on the fault conditions. Note that this counter will not increment in case of IERR error.

The `COMM_*_RC_STAT3` counter is incremented when a received command frame is discarded due to a fault. The discard reason is set in the fault registers when the actual discard event occurs. See the [Byte Errors](#) for details on the fault conditions. Note that this counter will not increment in case of IERR error.

### 8.5.1.4 Wakeup and Shutdown

#### 8.5.1.4.1 Base Device Wakeup and Hardware Shutdown

The WAKEUP input pin is used to wake up and reset the base device from SLEEP or SHUTDOWN mode. Additionally, the WAKEUP input defines a "base" device. The WAKEUP input pin is monitored continuously for a low pulse of at least  $t_{HLD\_WAKE}$  (but shorter than  $t_{HLD\_SD}$ ) followed by driving the input high. The command is accepted after WAKEUP is high for 30us. This high-low-high (1-0-1) transition (WAKE pulse) signals the BQ79606A-Q1 to enter ACTIVE mode. When a valid WAKEUP signal is received, all settings are reset to the OTP programmed values and the device enters ACTIVE mode and sends a WAKE tone up the stack. If already in ACTIVE mode, the settings are reset and the WAKE tone is sent up the stack. If a command to send a WAKE or SLEEPtoACTIVE tone is received while in the middle of sending a tone (WAKE or SLEEPtoACTIVE), the second command is ignored.

WAKEUP pin must be pulled up to VIO for a base device (for stack devices, connect WAKEUP pin to AVSS). When the IC exits a RESET condition (either through a software RESET, or receiving a WAKE pulse), the WAKEUP pin is sampled. If WAKEUP is high, the device is recognized as a "base" device and disables the COML receiver. This prevents an infinite communication loop when using the ring architecture.

The RX input pin of the UART interface is used to send a SLEEPtoACTIVE signal to the base device of a stack. Hold RX low for  $t_{UART(SIA)}$  to send a SLEEPtoACTIVE signal. When a valid SLEEPtoACTIVE signal is received in SLEEP mode, the BQ79606A-Q1 transitions to ACTIVE mode without resetting its parameters and sends a SLEEPtoACTIVE tone up the stack. Additionally, a communication clear is detected to clear the bus for new communication traffic. When a SLEEPtoACTIVE signal is received in ACTIVE mode, the BQ79606A-Q1 does not perform any action other than the communication clear and sending a SLEEPtoACTIVE tone up the stack. SLEEPtoACTIVE is ignored in [SHUTDOWN Mode](#). `COMM_FAULT` errors when sending a SLEEPtoACTIVE signal to the base device due to the communication clear. See [Communication Clear \(Break\) Detection](#) for details.

In addition to waking up the device, the WAKEUP input pin is used to send the device to SHUTDOWN mode when it does not respond to a normal reset command (either through the UART or WAKEUP). To send a HARDWARE SHUTDOWN command using WAKEUP pin, drive WAKEUP pin low for  $t_{HLD\_SD}$  followed by driving it high. The command is accepted after WAKEUP is high for 30us. Upon receiving the SHUTDOWN, the IC immediately enters SHUTDOWN mode. The next time the IC receives a WAKEUP command, it enters ACTIVE mode with the COMH and COML receivers and the COML transmitter are disabled (COMH transmitter is the only one that is enabled). This allows the base device to reject any communication from the stack while it is attempting to be re-initialized. The host must re-enable the necessary receivers before resuming normal operation.

After the wakeup or a shutdown pulse is received on the WAKEUP pin, the user should wait for the device to fully wake up ( $t_{SU(WAKE)}$ ) or fully shutdown ( $t_{SDorSLP}$ ) before sending another pulse in that pin.

Stack devices (devices communicating over the daisy chain only) must connect WAKEUP pin to AVSS to avoid being mis-recognized as a base device.

#### NOTE

When a WAKE or SLEEPtoACTIVE command is sent, the host MUST wait for the device to fully wake up ( $t_{SU(WAKE)}$ ) before sending additional WAKE, shutdown, or SLEEPtoACTIVE command. Failure to do so may result the device to enter unknown state.

**Table 23. Transition Table for Wakeup on Base Device**

Current State	WAKE Pulse (1-0-1 on WAKEUP pin)	SLEEPtoACTIVE Signal on RX Pin
SHUTDOWN	Transition to ACTIVE, perform soft-reset, propagate WAKE tone to the stack devices	Ignored, not propagated up the stack
SLEEP	Transition to ACTIVE, perform soft-reset, propagate WAKE tone to the stack devices	Transition to ACTIVE, propagate SLEEPtoACTIVE tone to the stack devices
ACTIVE	Perform soft-reset, propagate WAKE tone to the stack devices	No action, but propagate SLEEPtoACTIVE tone to the stack devices

#### 8.5.1.4.2 Stack Device Wakeup and Hardware Shutdown

The daisy-chain interface is capable of sending/receiving three different tones. The first, WAKE, resets all settings of the BQ79606A-Q1 and transitions the device to active mode. The second, SLEEPtoACTIVE, only transitions the BQ79606A-Q1 to active mode (if the device in sleep mode) and does NOT reset any settings. The third, SHUTDOWN, transitions the device to shutdown mode. In *SHUTDOWN Mode*, only the WAKE tone is recognized, any SHUTDOWN or SLEEPtoACTIVE tones are ignored. Both WAKE and SLEEPtoACTIVE tones are accepted and propagated during SLEEP and ACTIVE modes. The SHUTDOWN tone is accepted in SLEEP and ACTIVE modes, but NOT propagated up the stack. In ACTIVE mode, SLEEPtoACTIVE causes no action, however, it is propagated up the stack. WAKE tones are sent out under 4 conditions: when a WAKE tone is received, when a WAKEUP pulse occurs on the WAKEUP pin, when a soft reset is commanded through CONTROL1[SOFT\_RESET]=1 or when the CONTROL1[SEND\_WAKE] bit is set. Similarly, SLEEPtoACTIVE tones are sent out when a SLEEPtoACTIVE tone is received, when a SLEEPtoACTIVE command is received from the UART (RX hold low for  $t_{UART(SIA)}$ ), or when the CONTROL1[SEND\_SLPTOACT] bit is set. If a command to send a WAKE, SHUTDOWN, or SLEEPtoACTIVE tone is received while in the middle of sending a tone (WAKE, SHUTDOWN, or SLEEPtoACTIVE), the second command is ignored. A SHUTDOWN tone is only sent when the CONTROL1[SEND\_SHUTDOWN] bit is set. It is only sent to the next device in the stack and is not propagated. The SHUTDOWN tone command is intended to be a last effort to reset a device that has become unresponsive to normal reset methods (SOFT-RESET or WAKE). Once the SHUTDOWN tone is received, the device immediately transitions to SHUTDOWN mode. Unlike base devices, the receivers and transmitters for stack devices are unaffected by the SHUTDOWN tone.

**Table 24. Transition Table for Wake Tones on Stack Devices**

Current State	WAKE Action	SLEEPtoACTIVE Action	SHUTDOWN Action
SHUTDOWN	Transition to ACTIVE, perform soft-reset, propagate WAKE up the stack	Ignored, not propagated up the stack	Ignored, not propagated up the stack
SLEEP	Transition to ACTIVE, perform soft-reset, propagate WAKE up the stack	Transition to ACTIVE, propagate SLEEPtoACTIVE up the stack	Transition to SHUTDOWN, not propagated up the stack
ACTIVE	Perform soft-reset, propagate WAKE up the stack	No action, but propagate SLEEPtoACTIVE up the stack	Transition to SHUTDOWN, not propagated up the stack

The tones are made up of bit-pair couplets (complementary bits, similar to the daisy chain communication) transmitted at a fixed frequency. WAKE couplets are logic '1', while SHUTDOWN and SLEEPtoACTIVE couplets are logic '0'. All tones are transmitted at  $t_{\text{COMTONE}}$ . WAKE tones are detected once  $n_{\text{WAKEDET}}$  WAKE couplets are received. Similarly, a SLEEPtoACTIVE tone is detected once  $n_{\text{SLPtoACTDET}}$  SLEEPtoACTIVE/SHUTDOWN couplets are received and a SHUTDOWN tone is detected once  $n_{\text{SDNDET}}$  SLEEPtoACTIVE/SHUTDOWN couplets are received. See [Figure 30](#) for a graphical representation of the COM\* tones.

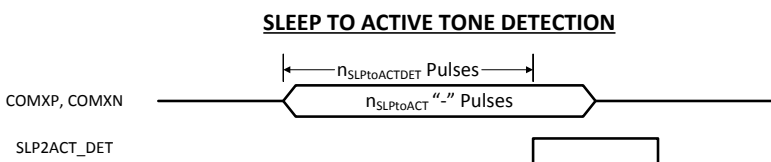
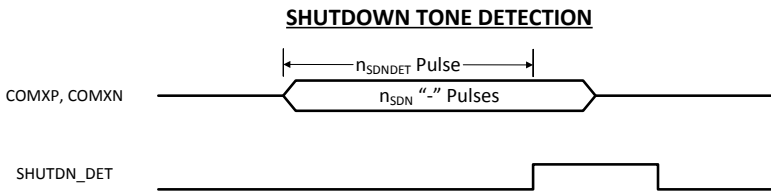
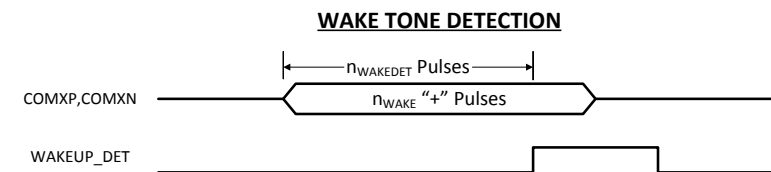
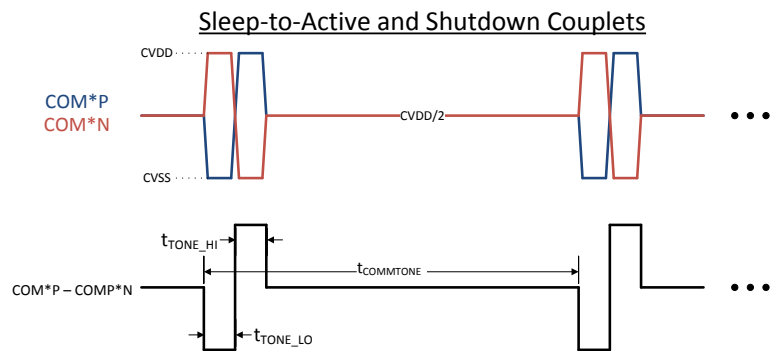
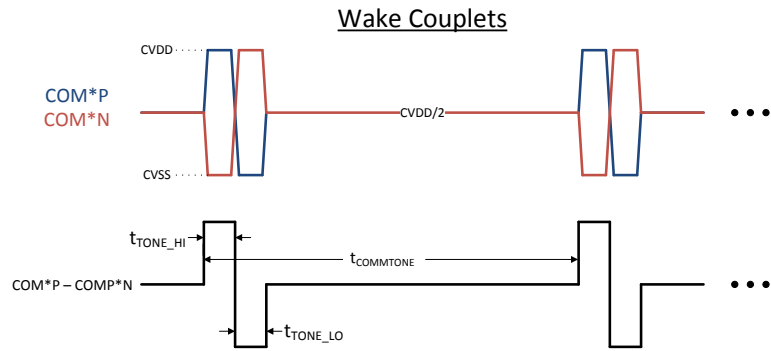

Figure 30. Communication Tones



### 8.5.1.5 Fault Handling

The BQ79606A-Q1 continuously monitors the battery voltage, battery temperature, die temperature, communications, and internal functions for faults and errors. When one of the monitored faults or errors occurs, the BQ79606A-Q1 alerts the host ( with NFAULT for base devices or FAULT tones for stack devices) to allow the host to handle the condition as is necessary. For every fault, there are 3 register bits. The status bit shows the fault is active, the reset bit is used to clear the fault, and the mask bit. Masking a fault prevents the external signaling (NFAULT for base devices or FAULT tones for stack devices). Any time an unmasked fault condition is triggered, the device signals the fault on the NFAULT output (base device) or sends a FAULT tone (stack device) down the stack. Faults are actively monitored in ACTIVE and SLEEP modes when enabled. Faults are NEVER monitored during *SHUTDOWN Mode*.

#### 8.5.1.5.1 Fault Status

When a fault occurs, the fault status bit is updated and if unmasked, the fault is indicated to the host. The host must then poll the status registers to determine which faults have occurred. A summary fault register (FAULT\_SUMMARY) is provided to reduce the number of registers to be polled when an error occurs. The summary register only shows UNMASKED faults. The following faults are covered by the summary register:

- FAULT\_SUMMARY[OTP\_FAULT] - Contains the aggregation of unmasked faults in the OTP\_FAULT register
- FAULT\_SUMMARY[SYS\_FAULT] - Contains the aggregation of unmasked faults in the RAIL\_FAULT, SYS\_FAULT1, SYS\_FAULT2, or SYS\_FAULT3 registers
- FAULT\_SUMMARY[COMM\_FAULT] - Contains the aggregation of unmasked faults in the TONE\_FAULT, COMM\_UART\_FAULT, COMM\_UART\_RC\_FAULT, COMM\_UART\_RR\_FAULT, COMM\_UART\_TR\_FAULT, COMM\_COMH\_FAULT, COMM\_COMH\_RC\_FAULT, COMM\_COMH\_RR\_FAULT, COMM\_COMH\_TR\_FAULT, COMM\_COML\_FAULT, COMM\_COML\_RC\_FAULT, COMM\_COML\_RR\_FAULT, or COMM\_COML\_TR\_FAULT registers.
- FAULT\_SUMMARY[GPIO\_OTUT] - Contains the aggregation of unmasked faults in the OT\_FAULT, UT\_FAULT, or OTUT\_BIST\_FAULT registers.
- FAULT\_SUMMARY[CELL\_OVUV] - Contains the aggregation of unmasked faults in the OV\_FAULT, UV\_FAULT or OVUV\_BIST\_FAULT registers.
- FAULT\_SUMMARY[GPIO\_FAULT] - Contains the aggregation of unmasked faults in the GPIOFAULT registers.

The following registers hold the status bits that create faults when unmasked:

- GPIO\_FAULT - GPIO input faults (if enabled)
- UV\_FAULT - Cell under-voltage comparator fault (if enabled)
- OV\_FAULT - Cell over-voltage comparator faults (if enabled)
- UT\_FAULT - Cell under-temperature comparator fault (if enabled)
- OT\_FAULT - Cell over-temperature comparator faults (if enabled)
- TONE\_FAULT - FAULT\* interface faults (if enabled)
- COMM\_UART\_FAULT - UART bus protocol faults
- COMM\_UART\_RC\_FAULT - UART bus command frame receive faults
- COMM\_UART\_RR\_FAULT - UART bus response frame receive faults. This register is only valid during multidrop mode.
- COMM\_UART\_TR\_FAULT - UART bus transmit faults
- COMM\_COMH\_FAULT - COMH bus protocol faults
- COMM\_COMH\_RR\_FAULT - COMH bus response frame receive faults
- COMM\_COMH\_RC\_FAULT - COMH bus command frame receive faults
- COMM\_COMH\_TR\_FAULT - COMH bus transmit faults
- COMM\_COML\_FAULT - COML bus protocol faults
- COMM\_COML\_RC\_FAULT - COML bus command frame receive faults
- COMM\_COML\_RR\_FAULT - COML bus response frame receive faults
- COMM\_COML\_TR\_FAULT - COML bus transmit faults
- OTP\_FAULT - OTP load or page faults
- RAIL\_FAULT - Power supply faults

- SYS\_FAULT1 - Internal IC faults
- SYS\_FAULT2 - Internal IC faults
- SYS\_FAULT3 - Internal IC faults
- OVUV\_BIST\_FAULT - OVUV BIST has failed (if enabled)
- OTUT\_BIST\_FAULT - OTUT BIST has failed (if enabled)

#### 8.5.1.5.1.1 Fault Reset

The fault status bits for the BQ79606A-Q1 are latched until cleared using the reset bit. Once cleared, the NFAULT indication (base device, if enabled) discontinues and the fault heartbeat (stack devices, if enabled) resumes. If the fault condition persists and the reset bit is written, the status bit is not reset (and remains indicated to host using NFAULT or the FAULT\* interface), The fault indicator cannot be reset until the underlying fault condition is eliminated. A corresponding group of registers hold reset bits for the fault registers.

- GPIO\_FLT\_RST - Reset bits for GPIO\_FAULT
- UV\_FLT\_RST - Reset bits for UV\_FAULT
- OV\_FLT\_RST - Reset bits for OV\_FAULT
- UT\_FLT\_RST - Reset bits for UT\_FAULT
- OT\_FLT\_RST - Reset bits for OT\_FAULT
- TONE\_FLT\_RST - Reset bits for FAULTSTAT
- COMM\_UART\_FLT\_RST - Reset bits for COMM\_UART\_FAULT
- COMM\_UART\_RC\_FLT\_RST - Reset bits for COMM\_UART\_RC\_FAULT
- COMM\_UART\_RR\_FLT\_RST - Reset bits for COMM\_UART\_RR\_FAULT
- COMM\_UART\_TR\_FLT\_RST - Reset bits for COMM\_UART\_TR\_FAULT
- COMM\_COMH\_FLT\_RST - Reset bits for COMM\_COMH\_FAULT
- COMM\_COMH\_RR\_FLT\_RST - Reset bits for COMM\_COMH\_RR\_FAULT
- COMM\_COMH\_RC\_FLT\_RST - Reset bits for COMM\_COMH\_RC\_FAULT
- COMM\_COMH\_TR\_FLT\_RST - Reset bits for COMM\_COMH\_TR\_FAULT
- COMM\_COML\_FLT\_RST - Reset bits for COMM\_UART\_FAULT
- COMM\_COML\_RC\_FLT\_RST - Reset bits for COMM\_COML\_RC\_FAULT
- COMM\_COML\_RR\_FLT\_RST - Reset bits for COMM\_COML\_RR\_FAULT
- COMM\_COML\_TR\_FLT\_RST - Reset bits for COMM\_COML\_TR\_FAULT
- OTP\_FLT\_RST - Reset bits for OTP\_FAULT
- RAIL\_FLT\_RST - Reset bits for RAIL\_FAULT
- SYS\_FLT1\_RST - Reset bits for SYS\_FAULT1
- SYS\_FLT2\_RST - Reset bits for SYS\_FAULT2
- SYS\_FLT3\_RST - Reset bits for SYS\_FAULT3
- OVUV\_BIST\_FLT\_RST - Reset bits for OVUV\_BIST\_FAULT
- OTUT\_BIST\_FLT\_RST - Reset bits for OTUT\_BIST\_FAULT

#### 8.5.1.5.2 Fault Masking

All of the possible faults in BQ79606A-Q1 may be masked by the host by setting the corresponding MASK bit. When masked, the FAULT\_SUMMARY register does not reflect the bit being set. Additionally, the NFAULT and FAULT\* interface do NOT signal when the masked event occurs, however, the status register is updated. NFAULT deasserts once the mask bit is set for the case of an existing fault. Masking bits also prevents cell balancing from terminating when the fault occurs (if enabled). Masking of fault sources is controlled in the following registers:

- GPIO\_FLT\_MSK - Mask bits for GPIO\_FAULT
- UV\_FLT\_MSK - Mask bits for UV\_FAULT
- OV\_FLT\_MSK - Mask bits for OV\_FAULT
- UT\_FLT\_MSK - Mask bits for UT\_FAULT
- OT\_FLT\_MSK - Mask bits for OT\_FAULT
- TONE\_FLT\_MSK - Mask bits for FAULTSTAT

- COMM\_UART\_FLT\_MSK - Mask bits for COMM\_UART\_FAULT
- COMM\_UART\_RC\_FLT\_MSK - Mask bits for COMM\_UART\_RC\_FAULT
- COMM\_UART\_RR\_FLT\_MSK - Mask bits for COMM\_UART\_RR\_FAULT
- COMM\_UART\_TR\_FLT\_MSK - Mask bits for COMM\_UART\_TR\_FAULT
- COMM\_COMH\_FLT\_MSK - Mask bits for COMM\_COMH\_FAULT
- COMM\_COMH\_RR\_FLT\_MSK - Mask bits for COMM\_COMH\_RR\_FAULT
- COMM\_COMH\_RC\_FLT\_MSK - Mask bits for COMM\_COMH\_RC\_FAULT
- COMM\_COMH\_TR\_FLT\_MSK - Mask bits for COMM\_COMH\_TR\_FAULT
- COMM\_COML\_FLT\_MSK - Mask bits for COMM\_UART\_FAULT
- COMM\_COML\_RC\_FLT\_MSK - Mask bits for COMM\_COML\_RC\_FAULT
- COMM\_COML\_RR\_FLT\_MSK - Mask bits for COMM\_COML\_RR\_FAULT
- COMM\_COML\_TR\_FLT\_MSK - Mask bits for COMM\_COML\_TR\_FAULT
- OTP\_FLT\_MSK - Mask bits for OTP\_FAULT
- RAIL\_FLT\_MSK - Mask bits for RAIL\_FAULT
- SYS\_FLT1\_MSK - Mask bits for SYS\_FAULT1
- SYS\_FLT2\_MSK - Mask bits for SYS\_FAULT2
- SYS\_FLT3\_MSK - Mask bits for SYS\_FAULT3
- OVUV\_BIST\_FLT\_MSK - Mask bits for OVUV\_BIST\_FAULT
- OTUT\_BIST\_FLT\_MSK - Mask bits for OTUT\_BIST\_FAULT

### 8.5.1.5.3 Fault Signaling

#### 8.5.1.5.3.1 NFAULT Output (Base Device)

The BQ79606A-Q1 integrates an open-drain output (NFAULT) to signal the host processor that a fault has occurred in the battery pack. The NFAULT output is enabled when the COMM\_CTRL[NFAULT\_EN] bit is set. When the BQ79606A-Q1 detects an unmasked fault, receives a fault tone on the FAULT\* interface, or the heartbeat from the device above stops (see [Daisy-Chain FAULT\\* Interface \(Stack Devices\)](#) for heartbeat details), NFAULT asserts low to signal the fault to the host. It is the responsibility of the host to read the stack of devices to determine where the fault occurred. If the FAULT\* interface is not enabled, it is the responsibility of the host to poll the status of the stack devices to monitor for faults. The NFAULT output only indicates faults in the base device for this condition.

#### 8.5.1.5.3.2 Daisy-Chain FAULT\* Interface (Stack Devices)

The FAULT\* interface is used to inform the host of faulted conditions on stack devices. FAULT uses two tones to supply the host with the current FAULT status. A periodic heartbeat tone monitors communication bus integrity, while a FAULTDET tone actively signals a fault has occurred. The FAULT\* interface is isolated in the same fashion as the daisy-chain interface. The FAULT\* interface transmitters and receivers are individually enabled/disabled using the DAISY\_CHAIN\_CTRL[FAULTTX\_EN] and DAISY\_CHAIN\_CTRL[FAULTRX\_EN] bits, respectively.

#### 8.5.1.5.3.2.1 FAULT\* Interface Tones

Similar to the communication bus tones, the FAULT bus uses two tones, a heartbeat tone and a fault detect tone, to communicate information. The tones are made up of bit-pair couplets (complementary bits, similar to the daisy chain communication) transmitted at a fixed frequency. Heartbeat couplets are logic '1', while fault detect couplets are logic '0'. All tones are transmitted at  $t_{FLTONE}$ . Heartbeat tones are detected once  $n_{FLTHBDET}$  heartbeat couplets are received. Similarly, a fault detected tone is detected once  $n_{FLTTONEDET}$  fault detect couplets are received. See [Figure 30](#) for a graphical representation of the COM\* tones.

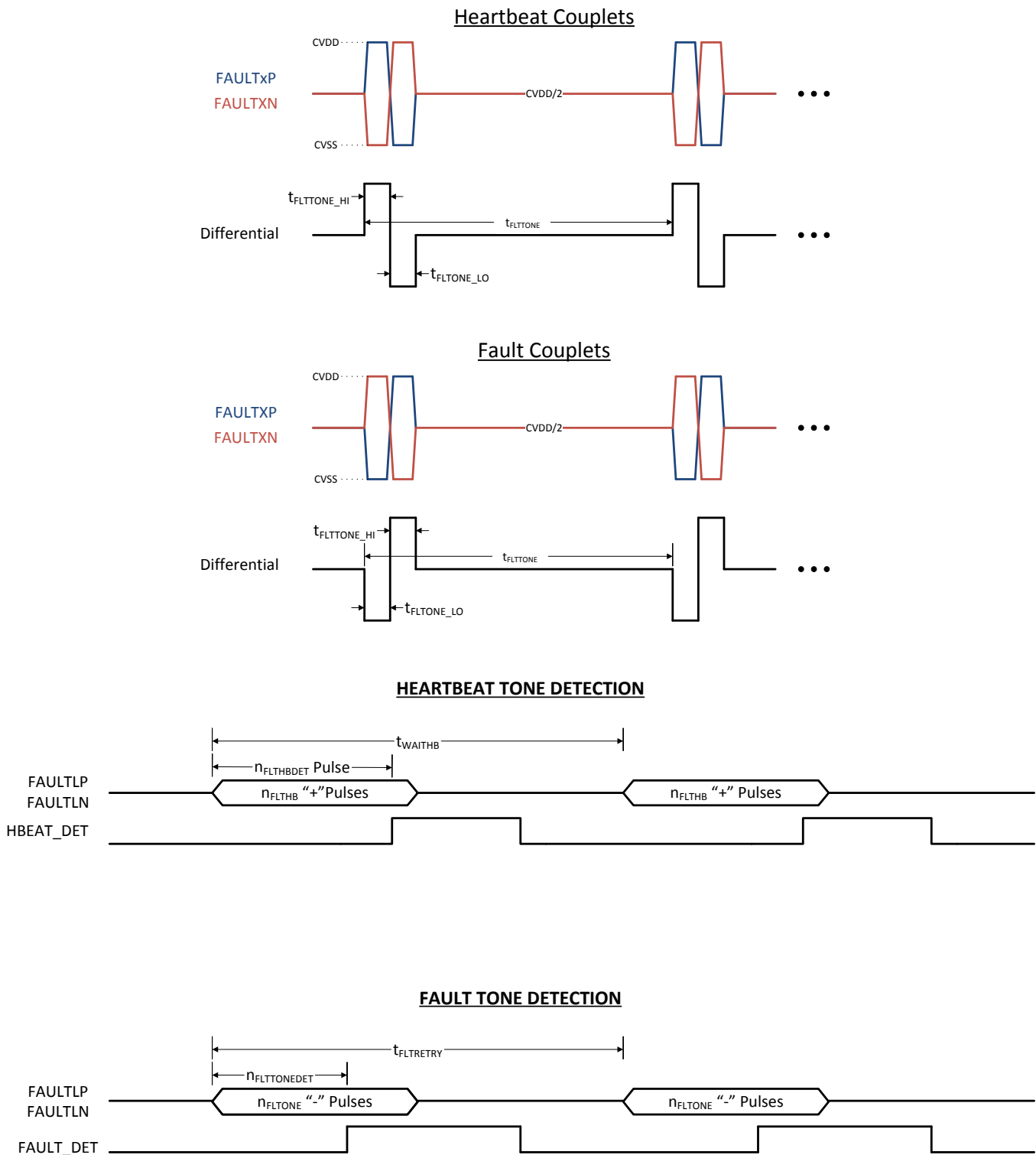

Figure 31. FAULT Tones

The daisy-chain transmits a heartbeat tone from north to south on the FAULT\* interface. The heartbeat tone is sent out every  $t_{WAITHB}$ . This is to monitor the integrity of the fault bus. The devices continuously monitors for the heartbeat of the device above. If a heartbeat pulse is not received for  $t_{HBT0}$ , TONE\_FAULT[HB\_FAIL] would get set. If it is unmasked and generation of fault tone transmit is enabled (COMM\_CTRL[FAULT\_HB\_EN] bit is enabled), a FAULT tone is sent down the FAULT\* interface. The timing allows for one missed heartbeat pulse due to noise. Additionally, during unmasked fault conditions and the heartbeats are enabled, the heartbeat is not generated. The fault must be masked, or cleared, to resume heartbeat generation given the heartbeat is enabled. See the table below for more details.

The device configured as the top of the stack must be set by the user in such a way that it does NOT monitor its FAULTP interface to avoid sending false heartbeat errors. If a heartbeat is received more often than expected (time between heartbeats is less than  $t_{HBFAST}$ ), the TONE\_FAULT[HB\_FAST] bit is set to indicate a possible error condition. This error indicates a problem with the FAULT bus. Either a device is damaged, or noise is causing a false receipt of the heartbeat tone. The heart beat counter is a free running counter, it is possible that when the TONE\_FAULT[HB\_FAIL] is detected, the TONE\_FAULT[HB\_FAST] can also be set. For that reason, it is recommended to read both HB\_FAST and HB\_FAIL bit at the same time and every time the TONE\_FAULT[HB\_FAIL] is detected, the TONE\_FAULT[HB\_FAST] should be ignored. Note that, if the FAULT line is held high or low for more than 20us (non zero differential value), this can be seen as a heart beat on the south device.

In case an unmasked fault is detected, the device sends a fault tone down the FAULT\* interface and stops sending any heartbeat tones until the fault is reset or cleared. As the lower devices receive the fault detected tone, the TONE\_FAULT[FF\_REC] bit is set and the fault tone is propagated down the stack until ultimately received by the base device, which notifies the host via the NFAULT output. Once the host receives the interrupt, it must read the stack to find the faulted device. Fault detect tones are sent out every  $t_{FLTRETRY}$  until the fault is reset and cleared. During SHUTDOWN mode, the FAULT\* interface is turned off and does NOT propagate fault detected tones. FAULT tones transmit are enabled/disabled using the COMM\_CTRL[FAULT\_TONE\_EN] bit.

**Table 25. Fault and Heartbeat Generation**

Condition	Unmasked Fault Tone Enabled	Heartbeat Enabled	Fault Generated	Heartbeat Generated
Fault	1	1	Yes	No
No Fault	1	1	No	Yes
Fault	0	1	No	Yes
No Fault	0	1	No	Yes
Fault	1	0	Yes	No
No Fault	1	0	No	No
Fault	0	0	No	No
No Fault	0	0	No	No

### 8.5.1.6 Communication Timeouts

There are two programmable communication timeout thresholds that monitor the absence of a valid frame from either UART or daisy chain communications. A valid frame is defined as any frame (response or command) that does NOT contain any errors that prevent the frame from being processed. These errors include: CRC errors, byte errors (COMM\_\*\_FAULT[BERR] = 1), start of frame errors (COMM\_\*\_FAULT[SOF] = 1), or frame initialization errors (COMM\_\*\_FAULT[IERR] = 1). The communication timeouts are only actively counting while in ACTIVE mode. The counters are disabled and reset during SHUTDOWN mode. In Sleep mode, the last counter values are held frozen.

#### 8.5.1.6.1 Short Communications Timeout Fault

The register COMM\_TO[SHORT] sets the acceptable period for no valid communications from either the UART interface or the daisy-chain interface. The timer is reset every time a valid response or 0 command frame is received. If enabled, when the timeout expires, the BQ79606A-Q1 recognizes a communication timeout fault and sets the SYS\_FAULT1[CTS] bit. To avoid getting a power-down communications fault before a communications timeout fault, ensure the COMM\_TO[SHORT] time is shorter than the COMM\_TO[LONG] time.

### 8.5.1.6.2 Long Communications Timeout Fault

The register COMM\_TO[LONG] sets the time period before the BQ79606A-Q1 shuts down due to lack of a valid communication frame from either the UART interface or the daisy-chain interface. Similar to the short communication fault, the timer is reset every time a valid response or command frame is received. If enabled, when the timer expires, the BQ79606A-Q1 enters SHUTDOWN mode. A wake up can recover the device from SHUTDOWN.

To avoid getting a power-down communications fault before a communications timeout fault, ensure the COMM\_TO[SHORT] time is shorter than the COMM\_TO[LONG] time.

### 8.5.1.7 Non-Volatile Memory

There are several memory locations that are programmable in non-volatile memory (NVM) using OTP. The OTP is loaded in both the factory and customer space with every reset event to supply the defaults for the corresponding register space. A reset occurs whenever a WAKE tone or WAKEUP is received by the device. Additionally, the host may perform a reset to the OTP defaults by writing the CONTROL1[SOFT\_RESET] bit. Writing this bit resets all of the registers to the OTP programmed value. Error check and correction (ECC, both single error correction, SEC and double error detection, DED) is performed during both the factory and customer space OTP load. Any load errors of the customer OTP space signal a fault using the OTP\_FAULT[CUSTLDERR]. Similarly, any load errors of the factory OTP space signal a fault using the OTP\_FAULT[FACTLDERR]. Additionally, the OTP space (factory and customer) are protected from data integrity problems using CRC. If any over-voltage error conditions exist in the OTP pages space (factory and customer), the OTP\_FAULT[GBLOVERR] bit is set. Information received from the device with this error must not be considered reliable.

#### 8.5.1.7.1 OTP Page Status

Due to the one time programming limitation of OTP NVM, two unused pages of OTP memory are available for the end customer to program. The status of the pages is held in the OTP\_CUST1\_STAT\* and OTP\_CUST2\_STAT\* registers. The OTP\_CUST1\_STAT1 and OTP\_CUST2\_STAT1 registers provide information on the current status of the page including the load status (if loaded, if loaded with error, if load failed), whether the page has been programmed successfully and is able to be loaded, or if the page is available for burning. OTP\_CUST1\_STAT2 and OTP\_CUST2\_STAT2 registers provide the programmed status.

When a reset occurs, the BQ79606A-Q1 evaluates the OTP page status and chooses the latest, valid OTP page to load. Page 2 has priority over page 1. If both pages have not been written, the factory OTP defaults (as indicated in the summary register table) are loaded. A valid page is one where the OTP\_CUST\*\_STAT1[PROGOK] bit is '1'. When the page is selected for loading, the OTP\_CUST\*\_STAT1[LOADED] bit is set. If a single error occurs in the loading of the page, the page is loaded after the single error is corrected and the OTP\_CUST\*\_STAT1[LOADWRN] bit is set. Additionally, the SEC\_BLK register is updated with the location of the error corrected block. If a double error occurs, the loading of that block is terminated and the hardware defaults of that block are loaded (as indicated in the summary register table). The overall page loading process is not terminated for a DED, only the affected block is terminated. When a DED occurs, the OTP\_CUST\*\_STAT1[LOADERR] bit is set. Additionally, the DED\_BLK register is updated with the block where the double error occurred. See the [Error Check and Correct \(ECC\) OTP](#) section for more details on error correction.

#### 8.5.1.7.2 Programming NVM

There are two pages of OTP memory available for customer use. To write the NVM, first the desired page is selected using the OTP\_PROG\_CTRL[PAGESEL] bit. The page must be valid to burn. A valid page is one where the OTP\_CUST\*\_STAT1[FREE] or OTP\_CUST\*\_STAT1[RETRY] is '1'. A page with the OTP\_CUST\*\_STAT1[FREE] bit set has never had programming attempted. A page with the OTP\_CUST\*\_STAT1[RETRY] bit set has had programming attempted, but an undervoltage error in VPROG occurred and programming was not completed. The status bits in OTP\_CUST\*\_STAT2 indicate the programming history of the page. During programming, if an OV or UV event occurs, the OTP\_CUST\*\_STAT2[UV\*OK] and OTP\_CUST\*\_STAT2[OV\*OK] bits are set to indicate the VPROG under and over voltage condition during the programming attempts. In addition, the UVERR, OVERR, SUVERR, and SOVERR bits on the OTP\_PROG\_STAT register indicates if there is VPROG error during programming and stability test.



To start the burn process, use the OTP\_PROG\_CTRL[PAGESEL] bits to select the page for programming. Next, connect a supply with voltage  $V_{\text{PROG}}$  to VPROG. This voltage is monitored internally during programming. Programming is aborted when a high/low voltage is connected while a burn is attempted. Once the voltage is connected, the four OTP\_PROG\_UNLOCK\* registers must be written. The registers are separated into two blocks (OTP\_PROG\_UNLOCK1\* and OTP\_PROG\_UNLOCK2\*) with four consecutive registers each (A, B, C, D). Each block of registers must be written in order (i.e. 1,2,3, then 4) with no other writes or reads between. The best practice is to use the same Write command to update. Any attempt to update the registers out of sequence, or if another register is written/read between writes, the entire sequence must be redone. OTP\_PROG\_UNLOCK1A-OTP\_PROG\_UNLOCK1D must be written to 0x02B778BC. OTP\_PROG\_UNLOCK2A-OTP\_PROG\_UNLOCK2D must be written to 0x7E12086F. Any reads done on the OTP\_PROG\_UNLOCK\* registers result in an all '0' response. Once these registers are written correctly, the OTP\_PROG\_STAT[UNLOCK] bit is set to signal the host that the OTP burn function is unlocked and enabled. Once the OTP is unlocked, the next write clears the lock condition. Reads can be done after unlocking the OTP (such as confirming the OTP\_PROG\_STAT[UNLOCK] bit is set). The write following the final unlock command must be to OTP\_PROG\_CTRL[PROG\_GO] to start the programming procedure. A successful program results in the OTP\_CUST\_STAT1[PROGOK] bit being set and the page is available for loading.

When the OTP programming is enabled, the VPROG voltage is tested in a voltage stability test. The voltage stability test lasts for 300us and checks the voltage for overvoltage and undervoltage conditions. If an overvoltage condition exists, the OTP\_PROG\_STAT[SOVERR] is set. If an undervoltage condition exists, the OTP\_PROG\_STAT[SUVERR] is set. If either condition exists during the test, the programming is terminated. Note that this will not set the OTP\_CUST\*\_STAT2[TRY1] (Meaning there are still two chances to burn the OTP).

Now, If the voltage is good during the stability test, programming proceeds. Once programming is completed, the OTP\_PROG\_STAT[DONE] bit is set. If any OV or UV errors occurred during the programming, the OTP\_PROG\_STAT[OVERR] or OTP\_PROG\_STAT[UVERR] bit (depending on which type of error) is set. If, after the first attempt at programming, the status shows an undervoltage error occurred (OTP\_CUST\*\_STAT2[TRY1], OTP\_CUST\*\_STAT2[OV1OK] is '1' and OTP\_CUST\*\_STAT2[UV1OK] is '0'), it is possible to retry the burn on that page with *EXACTLY* the same data only one more time. Note that, when the first attempt to program OTP failed, the user get only one more chance to burn properly the OTP.

If the host incorrectly selected a page for programming, the OTP\_PROG\_STAT[PROGERR] bit is set. This indicates that the selected page was not available to be programmed. Select the correct page and retry the programming.

#### 8.5.1.7.2.1 CUST OTP Programming

Here is a step by step on how to program customer page 1 or 2:

- Wake up the device and perform auto addressing
  - Apply 18V on BAT pin and wake up the devices
  - Perform Auto Addressing
  - Apply 7.6V on VPROG (With 100mA current Limit)
- Write to 0x100 to 0x103 registers the following values (respectively) to unlock the OTP programming
  - 0x02, 0xB7, 0x78, 0xBC
- Write to 0x150 to 0x153 register the following values (respectively) to unlock the OTP programming
  - 0x7E, 0x12, 0x08, 0x6F
- To check if everything is correct, read register 0x27D. This should indicate that there is no error and OTP is unlocked to be programmed (The unlock bit should be "1")
- Write 0x01 on register 0x107 this will program CUST1 (Page 1). Or write 0x03 to 0x107 for CUST2 (Page 2)
- Wait 200ms then read 0x27D to make sure no error occurred and the device programmed successfully.
- Remove 7.6V from VPROG
- Power cycle or soft reset and read the registers that were programmed to make sure they have the proper values



### 8.5.1.7.3 NVM CRC Testing

To determine register changes, the BQ79606A-Q1 constantly runs a background check on the register contents by computing a CRC and comparing it to a stored value. CRC testing is done for both the customer and factory register space. Customer register changes fall into several categories; intentional (that is, a change written by the host), unintentional (due to an unexpected device or system fault), or the result of an automated operation (such as the status bits for ADC conversion or cell balancing completion). The Register Summary indicates which host programmable registers are included in the CRC. The CUST\_CRC\_RSLTH and CUST\_CRC\_RSLTL registers hold the currently computed CRC value. This value is compared against the customer programmed value in the CRC registers. When updating a register covered in the CRC, the customer must update the CRC register. This is done by calculating the CRC, and writing the value to the CUST\_CRCH and CUST\_CRCL registers. The CRC is updated in the NVM along with the other register updates. The CRC calculation is done in the same manner (including the bit stream ordering) and with the same polynomial as described in [Calculating Frame CRC Value](#). The CRC check and comparison is done every  $t_{\text{CRC\_OTP}}$  and the DEV\_STAT[CRC\_DONE] bit is set after the check is complete. If the bit is already set, it remains set until cleared with a read.

### 8.5.1.7.4 CRC Faults

When CRC and CRC\_RSLT do not match, the SYS\_FAULT2[CUST\_CRC] flag is set until the condition is corrected. Continuous monitoring of the factory NVM space occurs in a similar fashion, concurrently with the monitoring of the USER space (customer). When a factory register change is detected, the SYS\_FAULT2[FACT\_CRC] flag is set. When this fault occurs, the host should reset the fault flag to see if the fault persists. If the fault persists, the customer firmware must perform a SOFT\_RESET of the part. If SOFT\_RESET does not correct the issue, the device is corrupted and must not be used.

### 8.5.1.7.5 Computing Customer CRC

The CRC check is done on all of the registers in the OTP space (as indicated in the Register Summary table). The register values are concatenated together with the lowest addressed register as the first data byte and the highest addressed register as the last data byte used in the CRC calculation. Using the same bit ordering as described in [Calculating Frame CRC Value](#) calculate the CRC on that number in the same manner and with the same polynomial as described in [Calculating Frame CRC Value](#).

### 8.5.1.8 Error Check and Correct (ECC) OTP

Register values for selected registers (0x0000 to 0x00C7) are permanently stored in OTP. All registers also exist as volatile storage locations at the same addresses, referred to as "shadow" registers. The volatile registers are for reading, writing, and device control. For a list of registers included in the OTP, see the Register Summary Table. During wakeup, the BQ79606A-Q1 first loads all shadow registers with hardware default values listed in the Register Summary. Then the BQ79606A-Q1 loads the registers conditionally with OTP contents from the results of the Error Check and Correct (ECC) evaluation of the OTP. The OTP is loaded to shadow registers in 64-bit blocks; each block has its own Error Check and Correct (ECC) value stored. The ECC detects a single-bit (Single-Error-Correction) or double-bit (Double-Error-Detection) changes in OTP stored data. The ECC is calculated for each block, individually. Single-bit errors are corrected, double-bit errors are only detected, not corrected. A block with good ECC is loaded. A block with a single-bit error is corrected, and the SYS\_FAULT3[SEC\_DET] bit is set to flag the corrected error event. Additionally, the SEC\_BLK register is updated with the location of the error corrected block. This enables the host to keep track of potentially damaged memory. The block is loaded to shadow registers after the single-bit error correction. Since the evaluation is on a block-by-block basis, it is possible for multiple blocks to have a single-correctable error and still be loaded correctly. Multiple-bit errors can exist with full correction, as long as they are limited to a single error per block. A block with a bad ECC comparison (two-bit errors in one block) is not loaded and the SYS\_FAULT3[DED\_DET] bit is set to flag the failed bit-error event. Additionally, the DED\_BLK register is updated with the block where the double error occurred. The hardware default value remains in the register. This allows some blocks to be loaded correctly (no fail or single-bit corrected value) and some blocks not to load. When either of the SYS\_FAULT3[SEC\_DET] or SYS\_FAULT3[DED\_DET] is set, and the condition is not cleared by a device reset (write CONTROL1[SOFT\_RESET] or a WAKE command), the device is corrupted and must not be used.

The ECC engine uses the industry standard 72,64 SEC DEC ECC implementation. The OTP is protected by a (72, 64) Hamming code, providing single error correction, double error detection (SECDED). For each 64-bits of data stored in OTP, an additional 8-bits of parity information are stored. Therefore, the ECC code imposes an area overhead on the OTP of  $(72 - 64) / 64$ , or 12.5%. The parity bits are designated p0, p1, p2, p4, p8, p16, p32 and p64. Bit p0 covers the entire encoded 72-bit ECC block. The remaining seven parity bits are assigned according to the following rule:

1. Parity bit p1 covers odd bit positions, i.e. bit positions which have the least significant bit of the bit position equal to 1 (1, 3, 5, etc.), including the p1 bit itself (bit 1).
2. Parity bit p2 covers bit positions which have the second least significant bit of the bit position equal to 1 (2, 3, 6, 7, 10, 11, etc.), including the p2 bit itself (bit 2).

The pattern continues for p4, p8, p16, p32 and p64. Table below specifies the complete encoding.

**Table 26. (72, 64) Parity Encoding**

Bit Position	71	70	69	68	67	66	65	64	63	62	61	60	59	58	57	56	55	54
Encoded Bits	d63	d62	d61	d60	d59	d58	d57	p64	d56	d55	d54	d53	d52	d51	d50	d49	d48	d47
Parity Bit Coverage	p0	x	x	x	x	x	x	x	x	x	x	x	x	x	x	x	x	x
	p1	x		x		x		x		x		x		x		x		x
	p2	x	x			x	x			x	x			x	x			x
	p4	x	x	x	x					x	x	x	x					x
	p8									x	x	x	x	x	x	x	x	
	p16									x	x	x	x	x	x	x	x	x
	p32									x	x	x	x	x	x	x	x	x
p64	x	x	x	x	x	x	x	x										
Bit Position	53	52	51	50	49	48	47	46	45	44	43	42	41	40	39	38	37	36
Encoded Bits	d46	d45	d44	d43	d42	d41	d40	d39	d38	d37	d36	d35	d34	d33	d32	d31	d30	d29
Parity Bit Coverage	p0	x	x	x	x	x	x	x	x	x	x	x	x	x	x	x	x	x
	p1	x		x		x		x		x		x		x		x		x
	p2			x	x			x	x			x	x		x	x		
	p4	x	x					x	x	x	x					x	x	x
	p8							x	x	x	x	x	x	x				
	p16	x	x	x	x	x	x											
	p32	x	x	x	x	x	x	x	x	x	x	x	x	x	x	x	x	x
p64																		
Bit Position	35	34	33	32	31	30	29	28	27	26	25	24	23	22	21	20	19	18
Encoded Bits	d28	d27	d26	p32	d25	d24	d23	d22	d21	d20	d19	d18	d17	d16	d15	d14	d13	d12
Parity Bit Coverage	p0	x	x	x	x	x	x	x	x	x	x	x	x	x	x	x	x	x
	p1	x		x		x		x		x		x		x		x		x
	p2	x	x			x	x			x	x			x	x			x
	p4					x	x	x	x					x	x	x	x	
	p8					x	x	x	x	x	x	x	x					
	p16					x	x	x	x	x	x	x	x	x	x	x	x	x
	p32	x	x	x	x													
p64																		
Bit Position	17	16	15	14	13	12	11	10	9	8	7	6	5	4	3	2	1	0
Encoded Bits	d11	p16	d10	d9	d8	d7	d6	d5	d4	p8	d3	d2	d1	p4	d0	p2	p1	p0

**Table 26. (72, 64) Parity Encoding (continued)**

Bit Position	71	70	69	68	67	66	65	64	63	62	61	60	59	58	57	56	55	54
Parity Bit Coverage	p0	x	x	x	x	x	x	x	x	x	x	x	x	x	x	x	x	x
	p1	x		x		x		x		x		x		x		x		x
	p2			x	x			x	x			x	x			x	x	
	p4			x	x	x	x					x	x	x	x			
	p8			x	x	x	x	x	x	x	x							
	p16	x	x															
	p32																	
	p64																	

**Table 27. Encoder and Decoder Data IN and OUT Positioning**

ENCODER			
DATA IN	Encoded Bits	DATA OUT	Bit Position
ECC_DATAIN 0	d0 to d7	ECC_DATAOUT0	0 to 7
ECC_DATAIN 1	d8 to d15	ECC_DATAOUT1	8 to 15
ECC_DATAIN 2	d16 to d23	ECC_DATAOUT2	16 to 23
ECC_DATAIN 3	d24 to d31	ECC_DATAOUT3	24 to 31
ECC_DATAIN 4	d32 to d39	ECC_DATAOUT4	32 to 39
ECC_DATAIN 5	d40 to d47	ECC_DATAOUT5	40 to 47
ECC_DATAIN 6	d48 to d55	ECC_DATAOUT6	48 to 55
ECC_DATAIN 7	d56 to d63	ECC_DATAOUT7	56 to 63
		ECC_DATAOUT8	64 to 71
DECODER			
DATA IN	Bit Position	DATA OUT	Decoded Bits
ECC_DATAIN 0	0 to 7	ECC_DATAOUT0	d0 to d7
ECC_DATAIN 1	8 to 15	ECC_DATAOUT1	d8 to d15
ECC_DATAIN 2	16 to 23	ECC_DATAOUT2	d16 to d23
ECC_DATAIN 3	24 to 31	ECC_DATAOUT3	d24 to d31
ECC_DATAIN 4	32 to 39	ECC_DATAOUT4	d32 to d39
ECC_DATAIN 5	40 to 47	ECC_DATAOUT5	d40 to d47
ECC_DATAIN 6	48 to 55	ECC_DATAOUT6	d48 to d55
ECC_DATAIN 7	56 to 63	ECC_DATAOUT7	d56 to d63
ECC_DATAIN 8	64 to 71		

### 8.5.1.8.1 ECC Diagnostic Test

The BQ79606A-Q1 provides a diagnostic tool to test the ECC function. There are two modes that are available to run the diagnostic. The first, auto mode (ECC\_TEST[MANUAL\_AUTO]=0), uses internal data to run the tests. In auto mode, the ECC\_TEST[DED\_SEC] bit selects the type of test that is to be done and the ECC\_TEST[ENC\_DEC] bit determines if the encoder or decoder function is to be tested. The result of the ECC test is provided in the ECC\_DATAOUT\* registers. The expected results from each test are shown in [Table 28](#).

The second, manual mode (ECC\_TEST[MANUAL\_AUTO] = 1) ECC function allows the user to insert their own SEC or DED errors into the ECC tester. The ECC\_DATAIN\* registers are used to write the values for the test. The ECC is calculated using the information in the previous section. The ECC\_DATAOUT\* registers output the result of the test. The SYS\_FAULT3[SEC\_DET] and SYS\_FAULT3[DED\_DET] bits indicate which type of error (if any) is detected for the decoding test ONLY. Make sure to clear these bits while disabling the ECC test before starting a decoding test. For the encoding test, these bits do not get updated or affected by the encoding test. Once the required test is configured and the SYS\_FAULT3 bits above are reset, write the ECC\_TEST[ENABLE]=1 to enable the test. Here are the recommended steps to execute the ECC for both the encoder and the decoding tests:

**Manual Decoding:**

1. Pick up any 72-bits value for the test and block write to ECC\_DATAIN[8:0]
2. Set the ECC\_TEST to manual ECC\_TEST[MANUAL\_AUTO]=1
3. Set decoder setting ECC\_TEST[ENC\_DEC]=0
4. Set decoder to single or double encoding setting with ECC\_TEST[DED\_SEC] (1 for DED or 0 for SEC)
5. Enable ECC test ECC\_TEST[ENABLE]=1
6. Clear all SEC/DED faults by SYS\_FLT3\_RST[SEC\_DET\_RST]=1 and SYS\_FLT3\_RST[DED\_DET\_RST]=1
7. Read SYS\_FAULT3[SEC\_DETECT] flag for SEC or SYS\_FAULT3[DED\_DETECT] flag for DED
8. Block read ECC\_DATAOUT[7:0] to verify the Decoder test results
9. Disable ECC test ECC\_TEST[ENABLE]=0.
10. Clear SEC/DEC faults.

**Manual Encoding steps:**

1. Pick up any 64-bits value for the test and block write to ECC\_DATAIN[7:0]
2. Set ECC\_TEST to manual ECC\_TEST[MANUAL\_AUTO]=1
3. Set the encoder setting using ECC\_TEST[ENC\_DEC]=1
4. Enable the ECC test with ECC\_TEST[ENABLE]=1
5. Ensure ECC\_DATAOUT[8:0] match the value in step “1”
6. Disable ECC test ECC\_TEST[ENABLE]=0.
7. Clear SEC/DEC faults.

**Automatic Decoding steps:**

1. Set ECC\_TEST to automatic ECC\_TEST[MANUAL\_AUTO]=0
2. Set decoder setting ECC\_TEST[ENC\_DEC]=0
3. Set decoder to single or double encoding setting with ECC\_TEST[DED\_SEC] (1 for DED or 0 for SEC)
4. Enable ECC test ECC\_TEST[ENABLE]=1
5. Clear all SEC/DED faults by SYS\_FLT3\_RST[SEC\_DET\_RST]=1 and SYS\_FLT3\_RST[DED\_DET\_RST]=1
6. Read SYS\_FAULT3[SEC\_DETECT] flag for SEC or SYS\_FAULT3[DED\_DETECT] flag for DED
7. Block read ECC\_DATAOUT[7:0] to verify the Decoder test results as in the table below
8. Disable ECC test ECC\_TEST[ENABLE]=0

**Automatic Encoding steps:**

1. Set ECC\_TEST to automatic ECC\_TEST[MANUAL\_AUTO]=0
2. Set the encoder setting using ECC\_TEST[ENC\_DEC]=1
3. Enable the ECC test with ECC\_TEST[ENABLE]=1
4. Block read ECC\_DATAOUT[8:0] to verify the Encoder test results as in the table below
5. Disable ECC test ECC\_TEST[ENABLE]=0

**Table 28. Automatic (ECC\_TEST[MANUAL\_AUTO]=0) ECC Diagnostic Results**

ECC_TEST[DED_SEC]	ECC_TEST[ENC_DEC]	SYS_FAULT3[SEC_DET]	SYS_FAULT3[DED_DET]	ECC_DATAOUT*
0 (SEC test)	0 (Decoder test)	1	0	0x18C3_FF8A_68A9_8069
0 (SEC test)	1 (Encoder test)	N/A	N/A	0xCD_3968_C140_2EA5_ED6D

**Table 28. Automatic (ECC\_TEST[MANUAL\_AUTO]=0) ECC Diagnostic Results (continued)**

ECC_TEST[DED_SEC]	ECC_TEST[ENC_DEC]	SYS_FAULT3[SEC_DE T]	SYS_FAULT3[DED_D ET]	ECC_DATAOUT*
1 (DED test)	0 (Decoder test)	0	1	0x0000_0000_0000_0000
1 (DED test)	1 (Encoder test)	N/A	N/A	0xCD_3968_C140_2EA5_ED6D

### 8.5.2 General Purpose IOs and SPI

The BQ79606A-Q1 integrates six general purpose input/outputs (GPIO). Registers GPIO1\_CONF - GPIO6\_CONF control the GPIO behavior. Each GPIO is programmable to be an input or an output. Additionally, GPIO1 - GPIO6 are configurable as ADC inputs either for NTC monitoring (ratiometric result) or absolute voltage measurement. GPIO1-GPIO6 are also configurable to be monitored by internal, hardware comparators for over/under-temperature monitoring. See [Cell Over/Under-Temperature Comparators](#) for more details.

The pullup and pulldowns are configurable (GPIO\*\_CONF[PUPD\_SEL]) to be FET push-pull (between VIO and DVSS), to have an weak pullup (to VIO) or weak pulldown (to DVSS) resistor enabled. Pull-downs must not be used in output mode. Additionally, push-pull mode must not be used in input mode. If either of these configurations are selected, correct operation is not guaranteed and undesirable operation may occur.

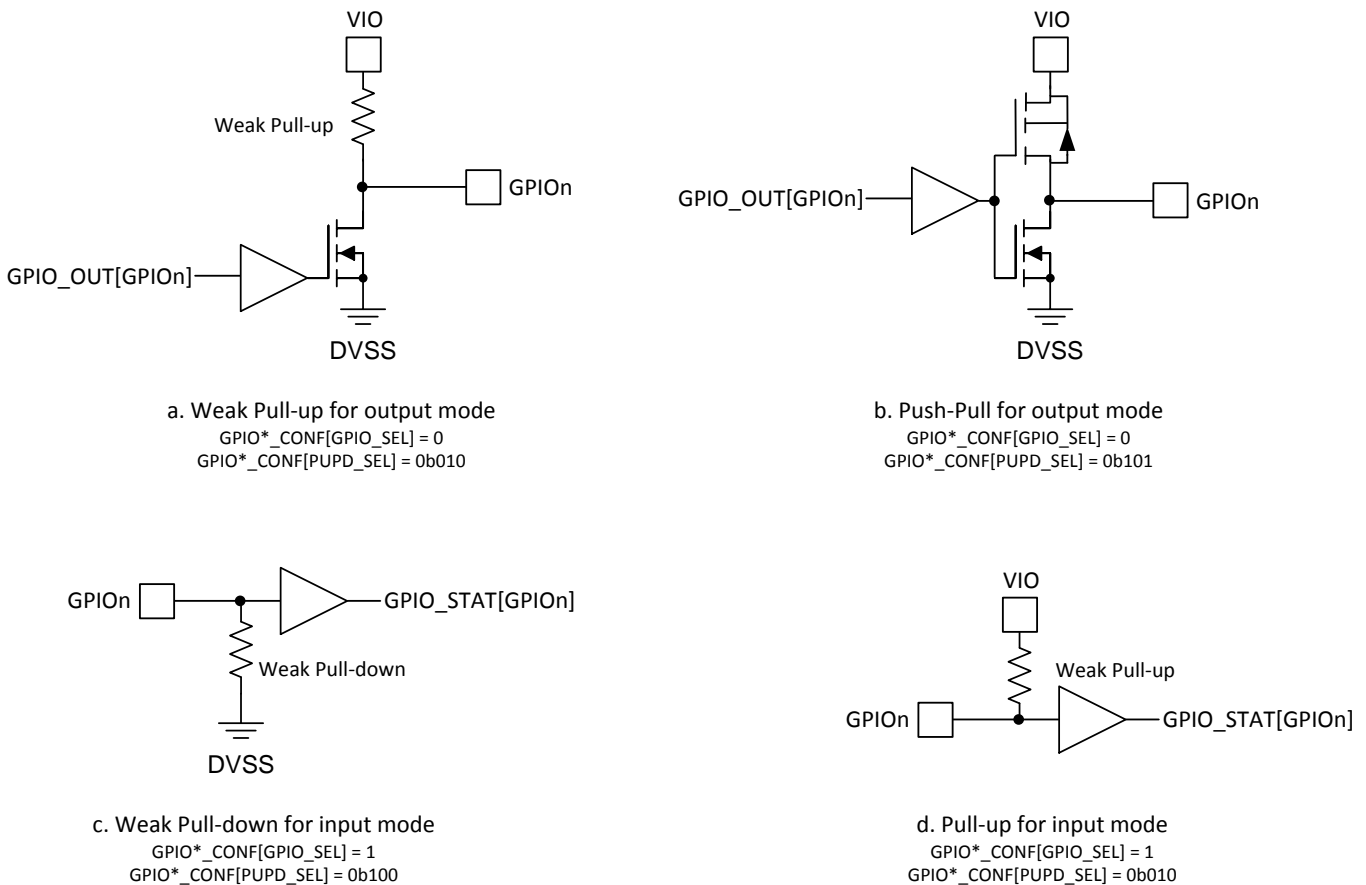

**Figure 32. Acceptable GPIO Input/Output Configurations**

There is a configurable option (GPIO\*\_CONF[FAULT\_EN]) for the GPIO to trigger a FAULT condition when high or low. When enabled, the GPIOs that are in a fault state set a flag in the GPIO\_FAULT register. These faults are triggered regardless of the GPIO\*\_CONF[GPIO\_SEL] setting for the GPIO (see the priority ranking below). Additionally, the GPIO\_STAT register shows the status ('0' or '1') of the individual GPIO pins regardless of input/output configuration. While configured as an output, the state of the GPIO is controlled using the GPIO\_OUT register.

There are several functions that utilize the GPIOs as listed below. As many of these functions may mistakenly be enabled simultaneously, there is a priority to the functions. The following list shows the GPIO function priority when multiple function are simultaneously enabled (1 is the highest priority and GPIO\*\_CONF refers to GPIO1\_CONF through GPIO6\_CONF registers):

1. SPI Master enabled (SPI\_CFG[SPI\_EN] = 1). GPIO\*\_CONF[GPIO\_SEL], GPIO\*\_CONF[FLT\_EN] and GPIO\*\_CONF[PUPD\_SEL] bits are ignored. This is only valid for GPIO3-GPIO6. GPIO1 and GPIO2 are unaffected when the SPI master is enabled.
2. GPIO Addressing enabled (GPIO\*\_CONF[ADD\_SEL] = 1). GPIO automatically setup as input. GPIO\*\_CONF[GPIO\_SEL], GPIO\*\_CONF[FLT\_EN] and GPIO\*\_CONF[PUPD\_SEL] bits are ignored. See the [GPIO Addressing](#) section for more details.
3. ADC measurements enabled (GPIO\*\_CONF[PUPD\_SEL] = 0b000)
4. Normal GPIO behavior (GPIO\*\_CONF[GPIO\_SEL] programmable) and GPIO configured as Fault (GPIO\*\_CONF[FLT\_EN] is set as fault low or high)

Note that the OT/UT function is not affected by the GPIO configuration. If enabled, the OT/UT function will signal faults as normal. For example, if the SPI master is enabled and the OT/UT function is enabled on GPIOs 3-6, faults are indicated as the clock and data are driven by the master (i.e. SCLK idling low trips the OT fault on GPIO6)

### 8.5.2.1 GPIO ADC Measurements

GPIO1 - GPIO6 are available to measure using the auxiliary ADC. To use the GPIO as ADC input, first configure the GPIO as an input using the corresponding GPIO\*\_CONF register. Enable the ADC conversion on the GPIO inputs using the AUX\_ADC\_CTRL1 register. Note If GPIO\* is weakly pulled-up (to VIO) and then a GPIO\* AUX\_ADC conversion is performed, the ADC data will correspond to 96% of VIO. This is due to the resistor divider in the ADCMUX circuit. See [AUX GPIO Input Measurement](#) for more details.

### 8.5.2.2 SPI Master Interface

The BQ79606A-Q1 GPIOs are configurable as a SPI master interface. The master is used to control devices such as an external OTP or the Active Balancing Chipset (EMB1428/EMB1499) from Texas Instruments. The SPI interface includes four I/Os: clock (SCLK), master data output (MOSI), master data input (MISO), and the slave select (SS). Three of the lines are shared by all devices on the SPI bus: SCLK, MOSI and MISO. SCLK is generated by the BQ79606A-Q1 ( $f_{SCLK}$ ) and is used for synchronization. MOSI and MISO are the data lines.

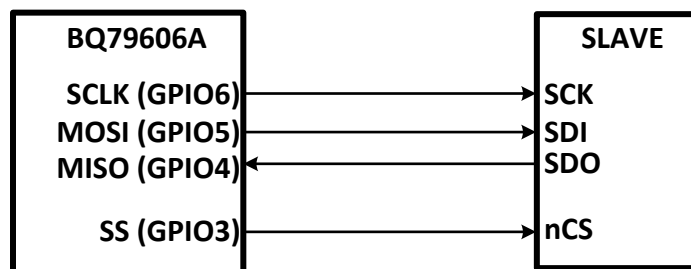

**Figure 33. SPI Configuration**

Each stack device is configurable to be a SPI master. The result looks something like [Figure 34](#).

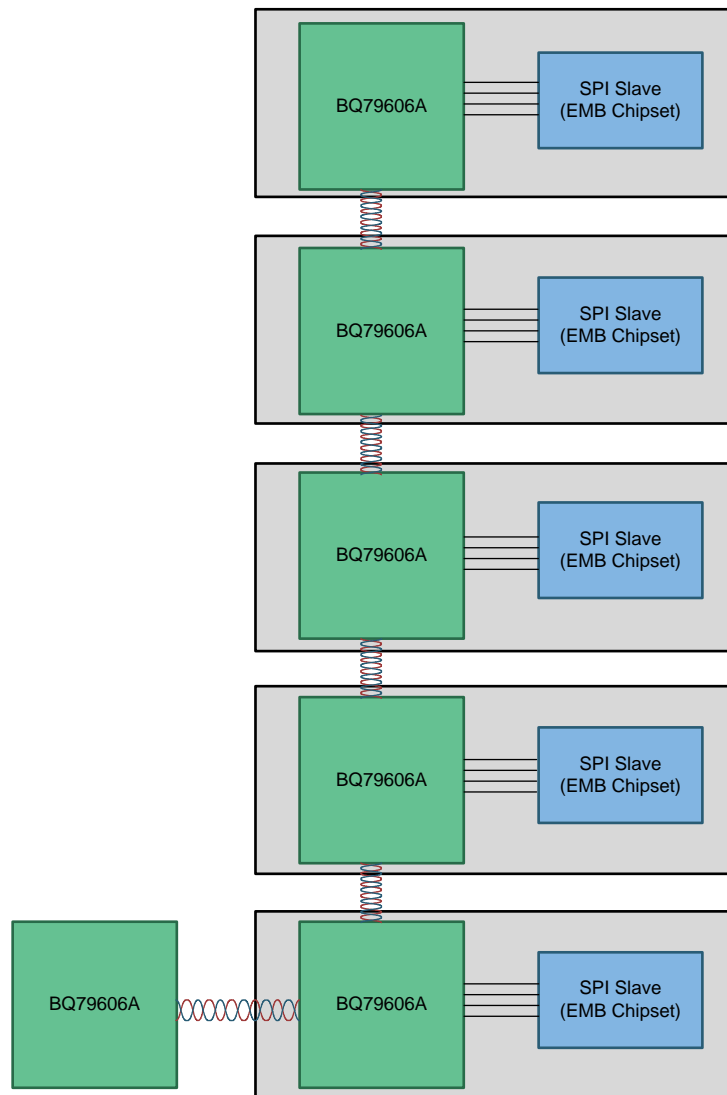
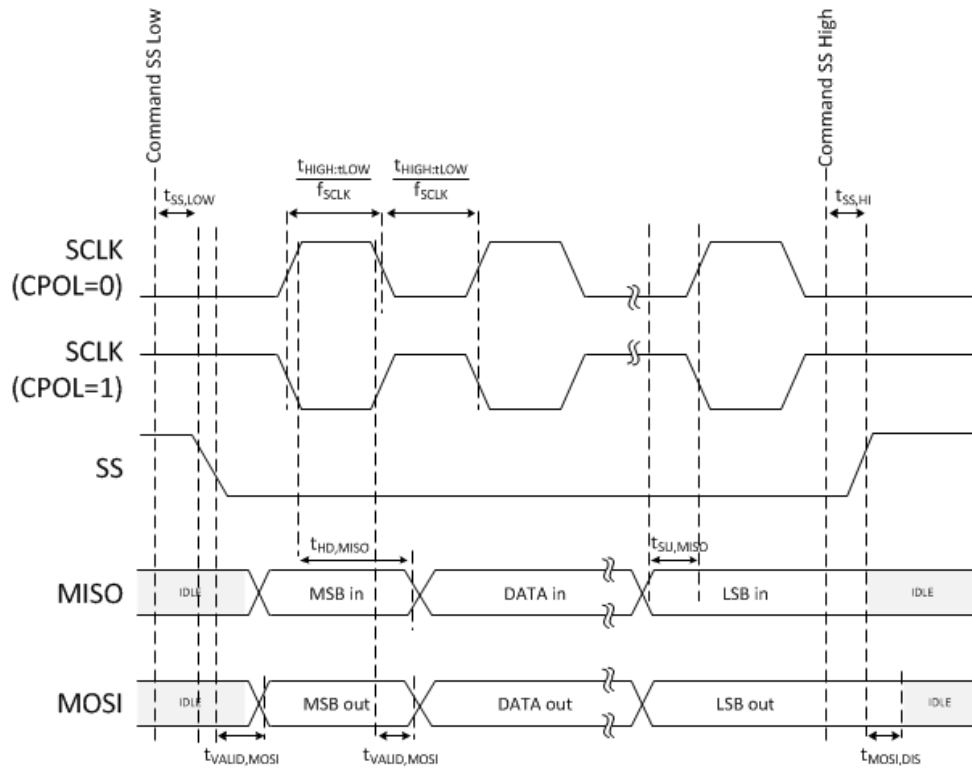

Figure 34. SPI Master Stack Configuration

The SPI timing diagram is shown in [Figure 35](#).





CPHA=0

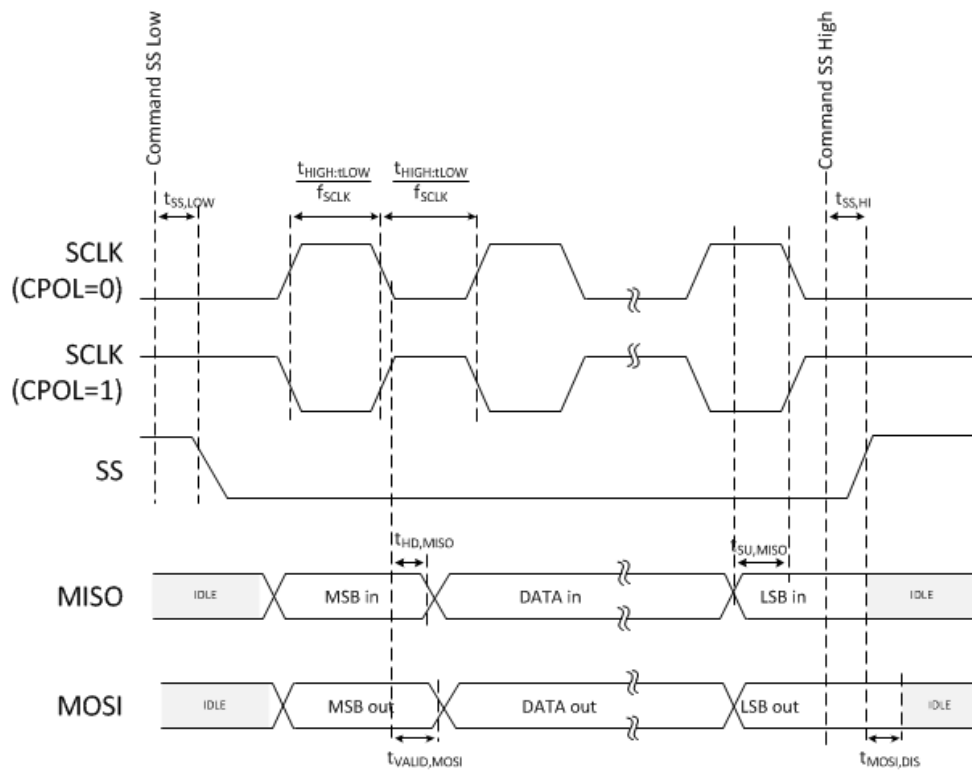

CPHA=1

Figure 35. SPI Timing Diagram

Clock polarity (CPOL) and clock phase (CPHA) define the SPI bus clock format. These are programmable for the BQ79606A-Q1 using the SPI\_CFG[CPOL] and SPI\_CFG[CPHA] bits. The SPI clock is inverted/non-inverted depending on CPOL parameter. The CPHA parameter shifts the sampling phase. While SPI\_CFG[CPHA]=0, MISO and MOSI are sampled on the leading (first) clock edge. When SPI\_CFG[CPHA]=1, MISO and MOSI are sampled on the trailing (second) clock edge, regardless of whether that clock edge is rising or falling. The following sections outline the behavior of CPHA and CPOL.

**8.5.2.2.1 CPOL=0, CPHA=0**

The data must be available before the first clock signal rising. The clock idle state is zero. The data on MISO and MOSI lines must be stable while the clock is high and are changed only when the clock is low. The data is captured on the clock's low-to-high transition and propagated on high-to-low clock transition.

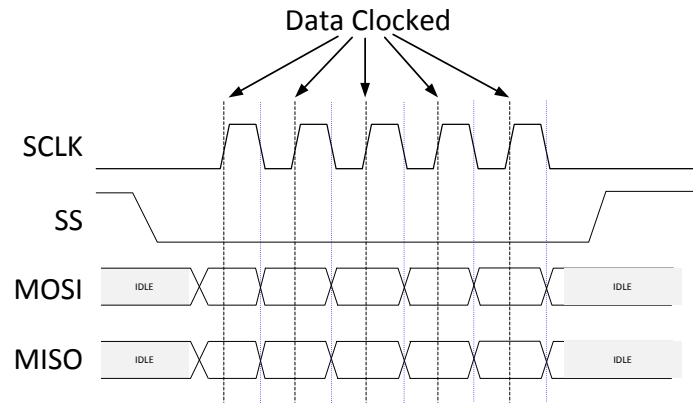
**Figure 36. CPOL=0, CPHA=0 Diagram**
**8.5.2.2.2 CPOL=0, CPHA=1**

The first clock signal rising is used to prepare the data. The clock idle state is zero. The data on MISO and MOSI lines must be stable while the clock is low and is only changed when the clock is high. The data is captured on the clock's high-to-low transition and propagated on low-to-high clock transition.

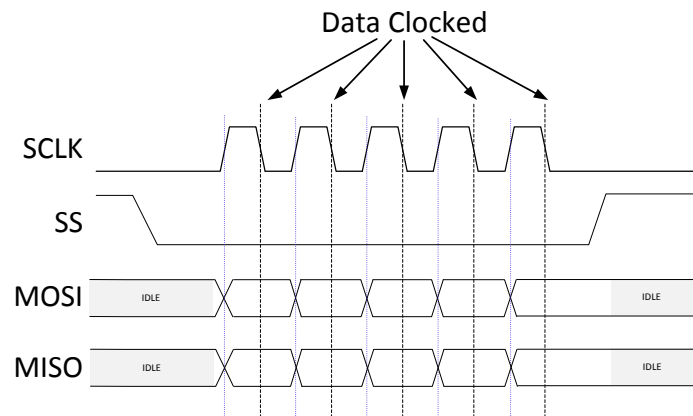
**Figure 37. CPOL=0, CPHA=1 Diagram**

8.5.2.2.3 CPOL=1, CPHA=0

The data must be available before the first clock signal falling. The clock idle state is one. The data on MISO and MOSI lines must be stable while the clock is low and is only changed when the clock is high. The data is captured on the clock's high-to-low transition and propagated on low-to-high clock transition.

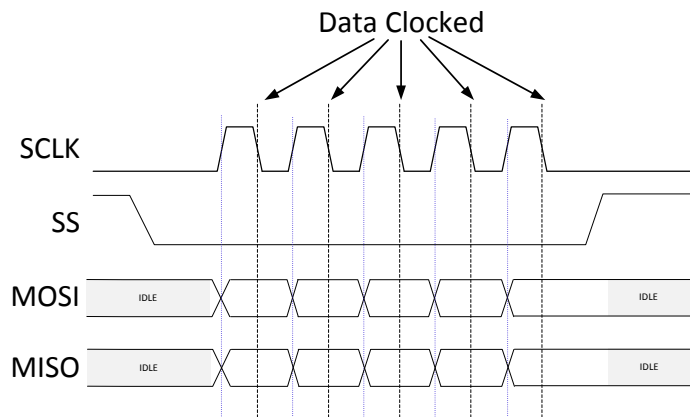

Figure 38. CPOL=1, CPHA=0 Diagram

8.5.2.2.4 CPOL=1, CPHA=1

The first clock signal falling is used to prepare the data. The clock idle state is one. The data on MISO and MOSI lines must be stable while the clock is high and can be changed when the clock is low. The data is captured on the clock's low-to-high transition and propagated on high-to-low clock transition.

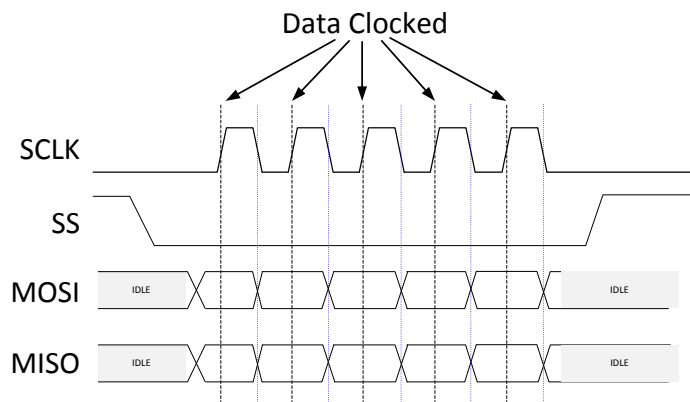

Figure 39. CPOL=1, CPHA=1 Diagram

8.5.2.2.5 SPI Master Protocol

The master is programmed using a combination of writes. A first write must be done to the SPI\_CFG register to configure the master for the transaction. The SPI\_CFG[SPI\_EN] bit is used to enable the SPI master interface, the SPI\_CFG[SS\_STAT] bit is used to select the slave device, and finally, the SPI\_CFG[NUMBITS] sets how many bits the transaction is (1-bit to 8-bit transaction). SPI\_CFG[NUMBITS] is only read by the device when the SPI\_GO command is executed. After the SPI is configured, write to the SPI\_EXE[SPI\_GO] bit to execute the transaction. Once the SPI\_EXE[SPI\_GO] is written to a '1', a SPI transaction of a length set by SPI\_CFG[NUMBITS] is executed. The SPI\_CFG[SS\_STAT] write and the SPI\_EXE[SPI\_GO] write must be two separate transaction to guarantee a properly executed transaction. The transaction writes the bits in the SPI\_TX register to the slave device and simultaneously reads the bits from the slave device to the SPI\_RX register. For an 8-bit write, the full byte is used. For less than 8-bit transactions, the write is done starting with the LSB and the read updates starting with LSB. For example, for a 3-bit transaction, bits 2:0 of the register SPI\_TX are written to MOSI while the bits 2:0 of SPI\_RX updated with the read data from MISO. Due to the simultaneous

read and write of the data, the SPI master supports both types of SPI devices. For devices where read/write are separate transactions, SPI\_RX is a "don't care" when a write is done. Multiple writes or read are possible while the SS pin of a particular device is selected. This enables support for SPI slaves that larger than 8-bit transactions. Multiple transactions must be done while SS is selected to complete larger than 8-bit transactions. Once the read or write is complete, set the SPI\_CFG[SS\_STAT] bit to end the transaction.

It should be noted that before the SPI\_CFG[SPI\_EN] bit is set, the SPI interface pins are configured by the GPIO\*\_CONF registers. This could lead to invalid states on the SPI pins (from the SPI interface perspective). For example, if the GPIO\*\_CONF registers have GPIO3 configured as an input, with the SPI function disabled GPIO3 (SS) may be low, selecting the slave device without intending to. If this is an issue for the application, use an external pull up to VIO to ensure the correct state for the slave. Once SPI is enabled, all of the GPIOs are set in accordance to the SPI\_CFG register.

#### NOTE

Do not change the CPHA (SPI\_CFG[CPHA])/CPOL (SPI\_CFG[CPOL]) values and the SS output (SPI\_CFG[SS\_STAT]) in a single write transaction as this may result in changing the idle clock value while SS is active which results in a faulty communication.

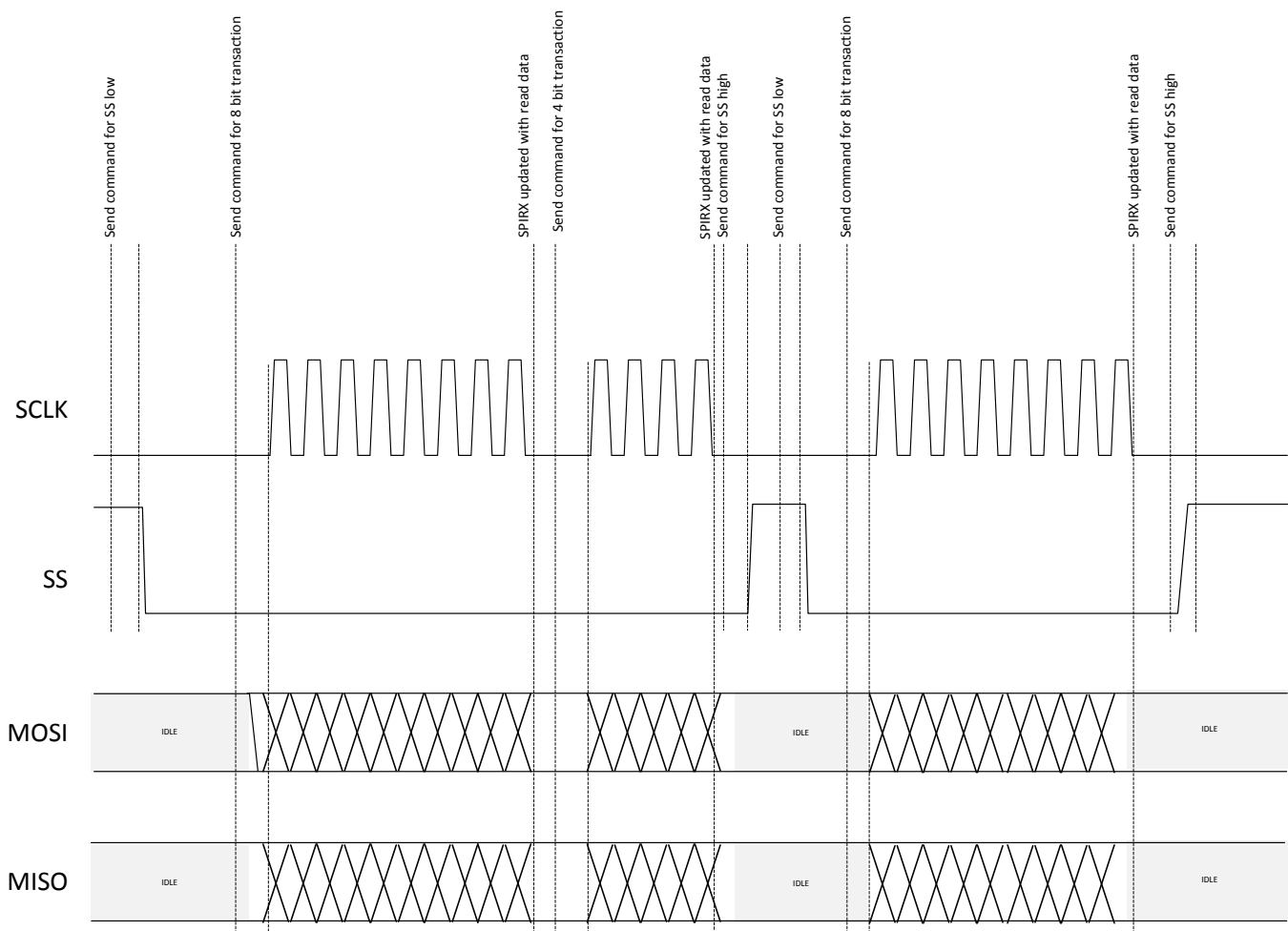

**Figure 40. SPI Command Frame Timing**

#### 8.5.2.2.5.1 SPI Write Examples

In the following example, an 8-bit write to the SPI slave of 0x3B is done. The slave has an active-low chip select with a (CPOL, CPHA) requirement of (0,0).

**Table 29. 8-Bit SPI Write Transaction**

Transaction	Register	Data	Comments
Write	SPI_TX	0x3B	Could be written as 1st or 2nd transaction
Write	SPI_CFG	0x08	SS low (start transaction), CPOL and CPHA = 0, SPI enabled, 8-bit transaction
Write	SPI_EXE	0x01	Execute write (0X3B sent out the MOSI output)
Write	SPI_CFG	0x18	SS high (stops transaction)

In the following example, an 12-bit write to the SPI slave of 0x73B is done. The slave has an active-low chip select with a (CPOL, CPHA) requirement of (0,0).

**Table 30. 12-Bit SPI Write Transaction**

Transaction	Register	Data	Comments
Write	SPI_TX	0x73	Could be written as 1st or 2nd transaction
Write	SPI_CFG	0x08	SS low (start transaction), CPOL and CPHA = 0, SPI enabled, 8-bit transaction
Write	SPI_EXE	0x01	Execute Write (0x73 sent out the MOSI output)
Write	SPI_TX	0x0B	Update lower bits of SPI_TX with the 4-bits
Write	SPI_CFG	0x0C	SS low (start transaction), CPOL and CPHA = 0, SPI enabled, 4-bit transaction
Write	SPI_EXE	0x01	Execute Write (0xB sent out the MOSI output)
Write	SPI_CFG	0x18	SS high, stops transaction

#### 8.5.2.2.5.2 SPI Read Examples

In the following example, an 8-bit read to the SPI slave done (0x3B is expected result). The slave has an active-low chip select with a (CPOL, CPHA) requirement of (0,0).

**Table 31. 8-Bit SPI Read Transaction**

Transaction	Register	Data	Comments
Write	SPI_CFG	0x08	SS low (start transaction), CPOL and CPHA = 0, SPI enabled, 8-bit transaction
Write	SPI_EXE	0x01	Execute read (0X3B received on the MISO input)
--	SPI_RX	0x3B	Updated by SPI
Write	SPI_CFG	0x18	SS high (stops transaction)
Read	SPI_RX	--	Read the result of the SPI read

In the following example, an 12-bit read to the SPI slave done (0x73B is expected result). The slave has an active-low chip select with a (CPOL, CPHA) requirement of (0,0).

**Table 32. 12-Bit SPI Read Transaction**

Transaction	Register	Data	Comments
Write	SPI_CFG	0x08	SS low (start transaction), CPOL and CPHA = 0, SPI enabled, 8-bit transaction
Write	SPI_EXE	0x01	Execute read (0X3B received on the MISO input)

**Table 32. 12-Bit SPI Read Transaction (continued)**

Transaction	Register	Data	Comments
--	SPI_RX	0x73	Updated by SPI
Read	SPI_RX	--	Read the result of the SPI read
Write	SPI_CFG	0x0C	Configure 4-bit transaction
Write	SPI_EXE	0x01	Execute read (0x07 received on the MISO input)
--	SPI_RX	0x0B	Lower 4-bits updated by SPI
Write	SPI_CFG	0x18	SS high (stops transaction)
Read	SPI_RX	--	Read the result of the SPI read

### 8.5.2.3 SPI Loopback Function

The SPI master has a loopback function that is enabled using the DIAG\_CTRL1[SPI\_LOOPBACK] bit. When enabled, the byte in the SPI\_TX register is clocked directly to the MISO pin of the SPI master to verify the SPI master functionality. This is done internally, so no external connection is required to run this test. This verifies that the SPI function is working correctly. The SPI\_CFG, SPI\_TX, and SPI\_EXE registers are written as a normal SPI transaction, but the external pins do not toggle during this mode. The expected result of the test is that the byte in the SPI\_TX register is read into the SPI\_RX register. The SS pin is latched to the setting in SPI\_CFG[SS\_STAT] that existed when the LOOPBACK mode was enabled. The CPHA and CPOL parameters must be set before entering LOOPBACK mode to ensure proper operation. Changing the CPOL or CPHA parameters while in LOOPBACK mode may result in errant pulses on the SPI outputs and is not recommended.

### 8.5.3 Safety Mechanisms

The BQ79606A-Q1 complies with applicable component level requirements for ASIL-D. The Safety Manual for BQ79606A-Q1 (SLUA822) and the BQ79606A-Q1 FMEDA documents are available separately from Texas Instruments. Contact TI Sales Associate or Applications Engineer for further information.



## 8.6 Register Maps

KEY: ADDR = Address; R = Read; W = Write; R/W = Read/Write; NVM = Non-volatile memory (OTP): 'Various' indicates that the value is set in the factory and is not consistent device to device.

Reserved bits that are located between 0x100 to 0x2E2 are not implemented in the design. Any writes to these bits are ignored. Reads to these bits always return '0'. However the reserved bits located between 0x00 to 0xC7 are implemented and is part of CRC calculation. The user should not write them. Spare bits are implemented in the design, but do not perform a function. These bits are read/write as normal, but do not influence any behaviors, but can be included in CRC calculation depending on the location (as indicated in the summary register table).

**General Note on Command Buffers:** There are three command buffers (one for UART, COMH, and COML) which assemble frames as they are received. The command buffers check for IERR, SOF, BERR and CRC. If a frame is valid and passes all those checks, then it gets sent to the command processor, which then checks TXDIS and UNEXP.

Register details are shown using the format shown in [Table 33](#)

**Table 33. Register Details**

REGISTERSNAME Register Address: REGISTER ADDRESS							
B7	B6	B5	B4	B3	B2	B1	B0
Bit Name	Bit Name	Bit Name	Bit Name	Bit Name	Bit Name	Bit Name	Bit Name
Bit 7 Hardware Default	Bit 6 Hardware Default	Bit 5 Hardware Default	Bit 4 Hardware Default	Bit 3 Hardware Default	Bit 2 Hardware Default	Bit 1 Hardware Default	Bit 0 Hardware Default
R-Read, W-Write, RW-Read/Write	R-Read, W-Write, RW-Read/Write	R-Read, W-Write, RW-Read/Write	R-Read, W-Write, RW-Read/Write	R-Read, W-Write, RW-Read/Write	R-Read, W-Write, RW-Read/Write	R-Read, W-Write, RW-Read/Write	R-Read, W-Write, RW-Read/Write
Bit Name [bit number]	Bit Description						
Bit Name [bit number]	Bit Description						

### 8.6.1 Customer Registers

#### 8.6.1.1 Register Summary Table

Addr	Register	Description	Reset Value	Included in CRC?	Factory OTP Reset Value	Included in NVM?
0x00	DEVADD_OTP	Device Address OTP Default	0x00	yes	0x00	yes
0x01	CONFIG	Device Configuration	0x00	yes	0x00	yes
0x02	GPIO_FLT_MSK	GPIO Fault Mask	0x00	yes	0x00	yes
0x03	UV_FLT_MSK	UV Comparator Fault Mask	0x00	yes	0x00	yes
0x04	OV_FLT_MSK	OV Comparator Fault Mask	0x00	yes	0x00	yes
0x05	UT_FLT_MSK	UT Comparator Fault Mask	0x00	yes	0x00	yes
0x06	OT_FLT_MSK	OT Comparator Fault Status Mask	0x00	yes	0x00	yes
0x07	TONE_FLT_MSK	FAULT_ Bus Tone Fault Mask	0x00	yes	0x00	yes
0x08	COMM_UART_FLT_MSK	UART Fault Mask	0x00	yes	0x00	yes
0x09	COMM_UART_RC_FLT_MSK	UART Receive Command Fault Mask	0x00	yes	0x00	yes
0x0A	COMM_UART_RR_FLT_MSK	UART Receive Response Fault Mask	0x00	yes	0x00	yes
0x0B	COMM_UART_TR_FLT_MSK	UART Transmit Fault Mask	0x00	yes	Various	yes

0x0C	COMM_COMH_FLT_MSK	COMH Bus Fault Mask	0x00	yes	0x00	yes
0x0D	COMM_COMH_RC_FLT_MSK	COMH Receive Command Fault Mask	0x00	yes	0x00	yes
0x0E	COMM_COMH_RR_FLT_MSK	COMH Receive Response Fault Mask	0x00	yes	0x00	yes
0x0F	COMM_COMH_TR_FLT_MSK	COMH Transmit Fault Mask	0x00	yes	0x00	yes
0x10	COMM_COML_FLT_MSK	COML Bus Fault Mask	0x00	yes	0x00	yes
0x11	COMM_COML_RC_FLT_MSK	COML Receive Command Fault Mask	0x00	yes	0x00	yes
0x12	COMM_COML_RR_FLT_MSK	COML Receive Response Fault Mask	0x00	yes	0x00	yes
0x13	COMM_COML_TR_FLT_MSK	COML Transmit Fault Mask	0x00	yes	0x00	yes
0x14	OTP_FLT_MSK	OTP Page Fault Mask	0x00	yes	0x00	yes
0x15	RAIL_FLT_MSK	Power Rail Fault Mask	0x00	yes	0x00	yes
0x16	SYS_FLT1_FLT_MSK	System Fault 1 Mask	0x00	yes	0x00	yes
0x17	SYS_FLT2_FLT_MSK	System Fault 2 Mask	0x00	yes	0x00	yes
0x18	SYS_FLT3_FLT_MSK	IC System Fault 3 Mask	0x00	yes	0x00	yes
0x19	OVUV_BIST_FLT_MSK	OVUV BIST Fault Mask	0x00	yes	0x00	yes
0x1A	OTUT_BIST_FLT_MSK	OTUT BIST Fault Mask	0x00	yes	0x00	yes
0x1B	SPARE_01	Spare Register	0x00	yes	Various	yes
0x1C	SPARE_02	Spare Register	0x00	yes	Various	yes
0x1D	SPARE_03	Spare Register	0x00	yes	Various	yes
0x1E	SPARE_04	Spare Register	0x00	yes	Various	yes
0x1F	SPARE_05	Spare Register	0x00	yes	Various	yes
0x20	COMM_CTRL	Communication Control	0x34	yes	0x3C	yes
0x21	DAISY_CHAIN_CTRL	Daisy Chain RX/TX Enable Control	0x3C	yes	0x3C	yes
0x22	TX_HOLD_OFF	Transmitter Holdoff Control	0x00	yes	0x00	yes
0x23	COMM_TO	Communication Timeout Control	0x00	yes	0x3C	yes
0x24	CELL_ADC_CONF1	Cell and DIETEMP ADC Configuration 1	0x60	yes	0x62	yes
0x25	CELL_ADC_CONF2	Cell and DIETEMP ADC Configuration 2	0x07	yes	0x08	yes
0x26	AUX_ADC_CONF	Auxiliary ADC Configuration	0x0C	yes	0x0C	yes
0x27	ADC_DELAY	ADC Configuration	0x00	yes	0x00	yes
0x28	GPIO_ADC_CONF	GPIO ADC Result Configuration	0x00	yes	0x00	yes
0x29	OVUV_CTRL	Cell Hardware Protection Channel Control	0x00	yes	0x00	no
0x2A	UV_THRESH	Comparator Under Voltage Threshold	0x60	yes	0x32	yes
0x2B	OV_THRESH	Comparator Over Voltage Threshold	0x60	yes	0x64	yes

0x2C	OTUT_CTRL	GPIO Over and Under Temperature Comparator Control	0x00	yes	0x00	yes
0x2D	OTUT_THRESH	Comparator Over Temperature Threshold	0x00	yes	0x5A	yes
0x2E	COMP_DG	Hardware Protection Deglitch	0x00	yes	0x0A	yes
0x2F	GPIO1_CONF	GPIO1 Configuration	0x30	yes	0x30	yes
0x30	GPIO2_CONF	GPIO2 Configuration	0x30	yes	0x30	yes
0x31	GPIO3_CONF	GPIO3 Configuration	0x30	yes	0x30	yes
0x32	GPIO4_CONF	GPIO4 Configuration	0x30	yes	0x30	yes
0x33	GPIO5_CONF	GPIO5 Configuration	0x30	yes	0x30	yes
0x34	GPIO6_CONF	GPIO6 Configuration	0x30	yes	0x30	yes
0x35	CELL1_GAIN	Cell 1 Gain Calibration	0x00	yes	0x00	yes
0x36	CELL2_GAIN	Cell 2 Gain Calibration	0x00	yes	0x00	yes
0x37	CELL3_GAIN	Cell 3 Gain Calibration	0x00	yes	0x00	yes
0x38	CELL4_GAIN	Cell 4 Gain Calibration	0x00	yes	0x00	yes
0x39	CELL5_GAIN	Cell 5 Gain Calibration	0x00	yes	0x00	yes
0x3A	CELL6_GAIN	Cell 6 Gain Calibration	0x00	yes	0x00	yes
0x3B	CELL1_OFF	Cell 1 Offset Calibration	0x00	yes	0x00	yes
0x3C	CELL2_OFF	Cell 2 Offset Calibration	0x00	yes	0x00	yes
0x3D	CELL3_OFF	Cell 3 Offset Calibration	0x00	yes	0x00	yes
0x3E	CELL4_OFF	Cell 4 Offset Calibration	0x00	yes	0x00	yes
0x3F	CELL5_OFF	Cell 5 Offset Calibration	0x00	yes	0x00	yes
0x40	CELL6_OFF	Cell 6 Offset Calibration	0x00	yes	0x00	yes
0x41	GPIO1_GAIN	GPIO1 Gain Calibration	0x00	yes	0x00	yes
0x42	GPIO2_GAIN	GPIO2 Gain Calibration	0x00	yes	0x00	yes
0x43	GPIO3_GAIN	GPIO3 Gain Calibration	0x00	yes	0x00	yes
0x44	GPIO4_GAIN	GPIO4 Gain Calibration	0x00	yes	0x00	yes
0x45	GPIO5_GAIN	GPIO5 Gain Calibration	0x00	yes	0x00	yes
0x46	GPIO6_GAIN	GPIO6 Gain Calibration	0x00	yes	0x00	yes
0x47	GPIO1_OFF	GPIO1 Offset Calibration	0x00	yes	0x00	yes
0x48	GPIO2_OFF	GPIO2 Offset Calibration	0x00	yes	0x00	yes
0x49	GPIO3_OFF	GPIO3 Offset Calibration	0x00	yes	0x00	yes
0x4A	GPIO4_OFF	GPIO4 Offset Calibration	0x00	yes	0x00	yes
0x4B	GPIO5_OFF	GPIO5 Offset Calibration	0x00	yes	0x00	yes
0x4C	GPIO6_OFF	GPIO6 Offset Calibration	0x00	yes	0x00	yes
0x4D	GPAUXCELL_GAIN	GP ADC Offset, CH1	0x00	yes	0x00	yes
0x4E	GPAUXCELL_OFF	GP ADC Offset, CH1	0x00	yes	0x00	yes

0x4F	GPAUX_GAIN	GP ADC Offset, CH2-32	0x00	yes	0x00	yes
0x50	GPAUX_OFF	GP ADC Offset, CH2-32	0x00	yes	0x00	yes
0x51	VC1COEFF1	Cell 1 ADC Gain Correction	0x00	yes	Various	yes
0x52	VC1COEFF2	Cell 1 ADC Gain Correction	0x00	yes	Various	yes
0x53	VC1COEFF3	Cell 1 ADC Gain Correction	0x00	yes	Various	yes
0x54	VC1COEFF4	Cell 1 ADC Gain Correction	0x00	yes	Various	yes
0x55	VC1COEFF5	Cell 1 ADC Gain Correction	0x00	yes	Various	yes
0x56	VC1COEFF6	Cell 1 ADC Gain Correction	0x00	yes	Various	yes
0x57	VC1COEFF7	Cell 1 ADC Gain Correction	0x00	yes	Various	yes
0x58	VC1COEFF8	Cell 1 ADC Gain Correction	0x00	yes	Various	yes
0x59	VC1COEFF9	Cell 1 ADC Offset/ Gain Correction	0x00	yes	Various	yes
0x5A	VC1COEFF10	Cell 1 ADC Offset Correction	0x00	yes	Various	yes
0x5B	VC1COEFF11	Cell 1 ADC Offset Correction	0x00	yes	Various	yes
0x5C	VC1COEFF12	Cell 1 ADC Offset Correction	0x00	yes	Various	yes
0x5D	VC1COEFF13	Cell 1 ADC Offset Correction	0x00	yes	Various	yes
0x5E	VC1COEFF14	Cell 1 ADC Offset Correction	0x00	yes	Various	yes
0x5F	VC2COEFF1	Cell 2 ADC Gain Correction	0x00	yes	Various	yes
0x60	VC2COEFF2	Cell 2 ADC Gain Correction	0x00	yes	Various	yes
0x61	VC2COEFF3	Cell 2 ADC Gain Correction	0x00	yes	Various	yes
0x62	VC2COEFF4	Cell 2 ADC Gain Correction	0x00	yes	Various	yes
0x63	VC2COEFF5	Cell 2 ADC Gain Correction	0x00	yes	Various	yes
0x64	VC2COEFF6	Cell 2 ADC Gain Correction	0x00	yes	Various	yes
0x65	VC2COEFF7	Cell 2 ADC Gain Correction	0x00	yes	Various	yes
0x66	VC2COEFF8	Cell 2 ADC Gain Correction	0x00	yes	Various	yes
0x67	VC2COEFF9	Cell 2 ADC Offset/ Gain Correction	0x00	yes	Various	yes
0x68	VC2COEFF10	Cell 2 ADC Offset Correction	0x00	yes	Various	yes
0x69	VC2COEFF11	Cell 2 ADC Offset Correction	0x00	yes	Various	yes
0x6A	VC2COEFF12	Cell 2 ADC Offset Correction	0x00	yes	Various	yes
0x6B	VC2COEFF13	Cell 2 ADC Offset Correction	0x00	yes	Various	yes
0x6C	VC2COEFF14	Cell 2 ADC Offset Correction	0x00	yes	Various	yes
0x6D	VC3COEFF1	Cell 3 ADC Gain Correction	0x00	yes	Various	yes
0x6E	VC3COEFF2	Cell 3 ADC Gain Correction	0x00	yes	Various	yes

0x6F	VC3COEFF3	Cell 3 ADC Gain Correction	0x00	yes	Various	yes
0x70	VC3COEFF4	Cell 3 ADC Gain Correction	0x00	yes	Various	yes
0x71	VC3COEFF5	Cell 3 ADC Gain Correction	0x00	yes	Various	yes
0x72	VC3COEFF6	Cell 3 ADC Gain Correction	0x00	yes	Various	yes
0x73	VC3COEFF7	Cell 3 ADC Gain Correction	0x00	yes	Various	yes
0x74	VC3COEFF8	Cell 3 ADC Gain Correction	0x00	yes	Various	yes
0x75	VC3COEFF9	Cell 3 ADC Offset/ Gain Correction	0x00	yes	Various	yes
0x76	VC3COEFF10	Cell 3 ADC Offset Correction	0x00	yes	Various	yes
0x77	VC3COEFF11	Cell 3 ADC Offset Correction	0x00	yes	Various	yes
0x78	VC3COEFF12	Cell 3 ADC Offset Correction	0x00	yes	Various	yes
0x79	VC3COEFF13	Cell 3 ADC Offset Correction	0x00	yes	Various	yes
0x7A	VC3COEFF14	Cell 3 ADC Offset Correction	0x00	yes	Various	yes
0x7B	VC4COEFF1	Cell 4 ADC Gain Correction	0x00	yes	Various	yes
0x7C	VC4COEFF2	Cell 4 ADC Gain Correction	0x00	yes	Various	yes
0x7D	VC4COEFF3	Cell 4 ADC Gain Correction	0x00	yes	Various	yes
0x7E	VC4COEFF4	Cell 4 ADC Gain Correction	0x00	yes	Various	yes
0x7F	VC4COEFF5	Cell 4 ADC Gain Correction	0x00	yes	Various	yes
0x80	VC4COEFF6	Cell 4 ADC Gain Correction	0x00	yes	Various	yes
0x81	VC4COEFF7	Cell 4 ADC Gain Correction	0x00	yes	Various	yes
0x82	VC4COEFF8	Cell 4 ADC Gain Correction	0x00	yes	Various	yes
0x83	VC4COEFF9	Cell 4 ADC Offset/ Gain Correction	0x00	yes	Various	yes
0x84	VC4COEFF10	Cell 4 ADC Offset Correction	0x00	yes	Various	yes
0x85	VC4COEFF11	Cell 4 ADC Offset Correction	0x00	yes	Various	yes
0x86	VC4COEFF12	Cell 4 ADC Offset Correction	0x00	yes	Various	yes
0x87	VC4COEFF13	Cell 4 ADC Offset Correction	0x00	yes	Various	yes
0x88	VC4COEFF14	Cell 4 ADC Offset Correction	0x00	yes	Various	yes
0x89	VC5COEFF1	Cell 5 ADC Gain Correction	0x00	yes	Various	yes
0x8A	VC5COEFF2	Cell 5 ADC Gain Correction	0x00	yes	Various	yes
0x8B	VC5COEFF3	Cell 5 ADC Gain Correction	0x00	yes	Various	yes
0x8C	VC5COEFF4	Cell 5 ADC Gain Correction	0x00	yes	Various	yes
0x8D	VC5COEFF5	Cell 5 ADC Gain Correction	0x00	yes	Various	yes
0x8E	VC5COEFF6	Cell 5 ADC Gain Correction	0x00	yes	Various	yes

0x8F	VC5COEFF7	Cell 5 ADC Gain Correction	0x00	yes	Various	yes
0x90	VC5COEFF8	Cell 5 ADC Gain Correction	0x00	yes	Various	yes
0x91	VC5COEFF9	Cell 5 ADC Offset/ Gain Correction	0x00	yes	Various	yes
0x92	VC5COEFF10	Cell 5 ADC Offset Correction	0x00	yes	Various	yes
0x93	VC5COEFF11	Cell 5 ADC Offset Correction	0x00	yes	Various	yes
0x94	VC5COEFF12	Cell 5 ADC Offset Correction	0x00	yes	Various	yes
0x95	VC5COEFF13	Cell 5 ADC Offset Correction	0x00	yes	Various	yes
0x96	VC5COEFF14	Cell 5 ADC Offset Correction	0x00	yes	Various	yes
0x97	VC6COEFF1	Cell 6 ADC Gain Correction	0x00	yes	Various	yes
0x98	VC6COEFF2	Cell 6 ADC Gain Correction	0x00	yes	Various	yes
0x99	VC6COEFF3	Cell 6 ADC Gain Correction	0x00	yes	Various	yes
0x9A	VC6COEFF4	Cell 6 ADC Gain Correction	0x00	yes	Various	yes
0x9B	VC6COEFF5	Cell 6 ADC Gain Correction	0x00	yes	Various	yes
0x9C	VC6COEFF6	Cell 6 ADC Gain Correction	0x00	yes	Various	yes
0x9D	VC6COEFF7	Cell 6 ADC Gain Correction	0x00	yes	Various	yes
0x9E	VC6COEFF8	Cell 6 ADC Gain Correction	0x00	yes	Various	yes
0x9F	VC6COEFF9	Cell 6 ADC Offset/ Gain Correction	0x00	yes	Various	yes
0xA0	VC6COEFF10	Cell 6 ADC Offset Correction	0x00	yes	Various	yes
0xA1	VC6COEFF11	Cell 6 ADC Offset Correction	0x00	yes	Various	yes
0xA2	VC6COEFF12	Cell 6 ADC Offset Correction	0x00	yes	Various	yes
0xA3	VC6COEFF13	Cell 6 ADC Offset Correction	0x00	yes	Various	yes
0xA4	VC6COEFF14	Cell 6 ADC Offset Correction	0x00	yes	Various	yes
0xA5	VAUXCOEFF1	GP ADC Gain Correction - CH2-32	0x00	yes	Various	yes
0xA6	VAUXCOEFF2	GP ADC Gain Correction - CH2-32	0x00	yes	Various	yes
0xA7	VAUXCOEFF3	GP ADC Gain Correction - CH2-32	0x00	yes	Various	yes
0xA8	VAUXCOEFF4	GP ADC Gain Correction - CH2-32	0x00	yes	Various	yes
0xA9	VAUXCOEFF5	GP ADC Gain Correction - CH2-32	0x00	yes	Various	yes
0xAA	VAUXCOEFF6	GP ADC Gain Correction - CH2-32	0x00	yes	Various	yes
0xAB	VAUXCOEFF7	GP ADC Gain Correction - CH2-32	0x00	yes	Various	yes
0xAC	VAUXCOEFF8	GP ADC Gain Correction - CH2-32	0x00	yes	Various	yes
0xAD	VAUXCOEFF9	GP ADC Offset Correction - CH2-32	0x00	yes	Various	yes
0xAE	VAUXCOEFF10	GP ADC Offset Correction - CH2-32	0x00	yes	Various	yes

0xAF	VAUXCOEFF11	GP ADC Offset Correction - CH2-32	0x00	yes	Various	yes
0xB0	VAUXCOEFF12	GP ADC Offset Correction - CH2-32	0x00	yes	Various	yes
0xB1	VAUXCOEFF13	GP ADC Offset Correction - CH2-32	0x00	yes	Various	yes
0xB2	VAUXCOEFF14	GP ADC Offset Correction	0x00	yes	Various	yes
0xB3	VAUXCELLCOEFF1	GP ADC Gain Correction - CH1	0x00	yes	Various	yes
0xB4	VAUXCELLCOEFF2	GP ADC Gain Correction - CH1	0x00	yes	Various	yes
0xB5	VAUXCELLCOEFF3	GP ADC Gain Correction - CH1	0x00	yes	Various	yes
0xB6	VAUXCELLCOEFF4	GP ADC Gain Correction - CH1	0x00	yes	Various	yes
0xB7	VAUXCELLCOEFF5	GP ADC Gain Correction - CH1	0x00	yes	Various	yes
0xB8	VAUXCELLCOEFF6	GP ADC Gain Correction - CH1	0x00	yes	Various	yes
0xB9	VAUXCELLCOEFF7	GP ADC Gain Correction - CH1	0x00	yes	Various	yes
0xBA	VAUXCELLCOEFF8	GP ADC Gain Correction - CH1	0x00	yes	Various	yes
0xBB	VAUXCELLCOEFF9	GP ADC Offset/ Gain Correction - CH1	0x00	yes	Various	yes
0xBC	VAUXCELLCOEFF10	GP ADC Offset Correction - CH1	0x00	yes	Various	yes
0xBD	VAUXCELLCOEFF11	GP ADC Offset Correction - CH1	0x00	yes	Various	yes
0xBE	VAUXCELLCOEFF12	GP ADC Offset Correction - CH1	0x00	yes	Various	yes
0xBF	VAUXCELLCOEFF13	GP ADC Offset Correction - CH1	0x00	yes	Various	yes
0xC0	VAUXCELLCOEFF14	GP ADC Offset Correction - CH1	0x00	yes	Various	yes
0xC1	SPARE_6	Spare Register	0x00	yes	Various	yes
0xC2	CUST_MISC1	Customer OTP Memory 1	0x00	yes	0x00	yes
0xC3	CUST_MISC2	Customer OTP Memory 2	0x00	yes	0x00	yes
0xC4	CUST_MISC3	Customer OTP Memory 3	0x00	yes	0x00	yes
0xC5	CUST_MISC4	Customer OTP Memory 4	0x00	yes	0x00	yes
0xC6	CUST_CRCH	Customer CRC High Byte	0xBE	no	Various	yes
0xC7	CUST_CRCL	Customer CRC Low Byte	0xA3	no	Various	yes
0x100	OTP_PROG_UNLOCK1A	OTP Program Unlock Code 1A	0x00	no	0x00	no
0x101	OTP_PROG_UNLOCK1B	OTP Program Unlock Code 1B	0x00	no	0x00	no
0x102	OTP_PROG_UNLOCK1C	OTP Program Unlock Code 1C	0x00	no	0x00	no
0x103	OTP_PROG_UNLOCK1D	OTP Program Unlock Code 1D	0x00	no	0x00	no
0x104	DEVADD_USR	Programmable Device Address	0x00	no	0x00	no
0x105	CONTROL1	Device Control	0x00	no	0x00	no
0x106	CONTROL2	Function Enable Control	0x00	no	0x00	no
0x107	OTP_PROG_CTRL	OTP Programming Control	0x00	no	0x00	no



0x108	GPIO_OUT	GPIO Output Control	0x00	no	0x00	no
0x109	CELL_ADC_CTRL	Cell ADC Control	0x00	no	0x00	no
0x10A	AUX_ADC_CTRL1	Auxiliary ADC Control 1	0x00	no	0x00	no
0x10B	AUX_ADC_CTRL2	Auxiliary ADC Control 2	0x00	no	0x00	no
0x10C	AUX_ADC_CTRL3	Auxiliary ADC Control 3	0x00	no	0x00	no
0x10D	CB_CONFIG	Balance Timer Configuration	0x00	no	0x00	no
0x10E	CB_CELL1_CTRL	Cell 1 Balance Timer Configuration	0x00	no	0x00	no
0x10F	CB_CELL2_CTRL	Cell 2 Balance Timer Configuration	0x00	no	0x00	no
0x110	CB_CELL3_CTRL	Cell 3 Balance Timer Configuration	0x00	no	0x00	no
0x111	CB_CELL4_CTRL	Cell 4 Balance Timer Configuration	0x00	no	0x00	no
0x112	CB_CELL5_CTRL	Cell 5 Balance Timer Configuration	0x00	no	0x00	no
0x113	CB_CELL6_CTRL	Cell 6 Balance Timer Configuration	0x00	no	0x00	no
0x114	CB_DONE_THRESH	Cell Balance Done Comparator Threshold	0x20	no	0x60	no
0x115	CB_SW_EN	Cell Balancing Manual Switch Enable	0x00	no	0x00	no
0x116	DIAG_CTRL1	Diagnostic Control Register 1	0x00	no	0x00	no
0x117	DIAG_CTRL2	Diagnostic Control Register 2	0x00	no	0x00	no
0x118	DIAG_CTRL3	Diagnostic Control Register 3	0x00	no	0x00	no
0x119	DIAG_CTRL4	Diagnostic Control Register 4	0x00	no	0x00	no
0x11A	VC_CS_CTRL	VC Current Source/Sink Control	0x00	no	0x00	no
0x11B	CB_CS_CTRL	CB Current Source/Sink Control	0x00	no	0x00	no
0x11C	CBVC_COMP_CTRL	CB Switch Comparator Control	0x00	no	0x00	no
0x11D	ECC_TEST	ECC Test	0x00	no	0x00	no
0x11E	ECC_DATAIN0	1st Data In Byte for Manual ECC Test	0x00	no	0x00	no
0x11F	ECC_DATAIN1	2nd Data In Byte for Manual ECC Test	0x00	no	0x00	no
0x120	ECC_DATAIN2	3rd Data In Byte for Manual ECC Test	0x00	no	0x00	no
0x121	ECC_DATAIN3	4th Data In Byte for Manual ECC Test	0x00	no	0x00	no
0x122	ECC_DATAIN4	5th Data In Byte for Manual ECC Test	0x00	no	0x00	no
0x123	ECC_DATAIN5	6th Data In Byte for Manual ECC Test	0x00	no	0x00	no
0x124	ECC_DATAIN6	7th Data In Byte for Manual ECC Test	0x00	no	0x00	no
0x125	ECC_DATAIN7	8th Data In Byte for Manual ECC Test	0x00	no	0x00	no
0x126	ECC_DATAIN8	9th Data In Byte for Manual ECC Test	0x00	no	0x00	no
0x127	GPIO_FLT_RST	GPIO Fault Reset	0x00	no	0x00	no
0x128	UV_FLT_RST	UV Comparator Fault Reset	0x00	no	0x00	no

0x129	OV_FLT_RST	OV Comparator Fault Status Reset	0x00	no	0x00	no
0x12A	UT_FLT_RST	UT Comparator Fault Status	0x00	no	0x00	no
0x12B	OT_FLT_RST	OT Comparator Fault Status	0x00	no	0x00	no
0x12C	TONE_FLT_RST	FAULT_ Bus Status Reset	0x00	no	0x00	no
0x12D	COMM_UART_FLT_RST	UART Fault Status Reset	0x00	no	0x00	no
0x12E	COMM_UART_RC_FLT_RST	UART Receive Command Fault Reset	0x00	no	0x00	no
0x12F	COMM_UART_RR_FLT_RST	UART Receive Response Fault Reset	0x00	no	0x00	no
0x130	COMM_UART_TR_FLT_RST	UART Transmit Fault Reset	0x00	no	0x00	no
0x131	COMM_COMH_FLT_RST	COMH Bus Fault Reset	0x00	no	0x00	no
0x132	COMM_COMH_RC_FLT_RST	COMH Receive Command Fault Reset	0x00	no	0x00	no
0x133	COMM_COMH_RR_FLT_RST	COMH Receive Response Fault Reset	0x00	no	0x00	no
0x134	COMM_COMH_TR_FLT_RST	COMH Transmit Fault Reset	0x00	no	0x00	no
0x135	COMM_COML_FLT_RST	COML Bus Fault Reset	0x00	no	0x00	no
0x136	COMM_COML_RC_FLT_RST	COML Receive Command Fault Reset	0x00	no	0x00	no
0x137	COMM_COML_RR_FLT_RST	COML Receive Response Fault Reset	0x00	no	0x00	no
0x138	COMM_COML_TR_FLT_RST	COML Transmit Fault Reset	0x00	no	0x00	no
0x139	OTP_FLT_RST	OTP Page Fault Reset	0x00	no	0x00	no
0x13A	RAIL_FLT_RST	Power Rail Fault Reset	0x00	no	0x00	no
0x13B	SYS_FLT1_RST	System Fault 1 Reset	0x00	no	0x00	no
0x13C	SYS_FLT2_RST	System Fault 2 Reset	0x00	no	0x00	no
0x13D	SYS_FLT3_RST	IC System Fault 3 Reset	0x00	no	0x00	no
0x13E	OVUV_BIST_FLT_RST	OVUV BIST Reset	0x00	no	0x00	no
0x13F	OTUT_BIST_FLT_RST	OTUT BIST Reset	0x00	no	0x00	no
0x150	OTP_PROG_UNLOCK2A	OTP Program Unlock Code 2A	0x00	no	0x00	no
0x151	OTP_PROG_UNLOCK2B	OTP Program Unlock Code 2B	0x00	no	0x00	no
0x152	OTP_PROG_UNLOCK2C	OTP Program Unlock Code 2C	0x00	no	0x00	no
0x153	OTP_PROG_UNLOCK2D	OTP Program Unlock Code 2D	0x00	no	0x00	no
0x154	SPI_CFG	SPI Master Configuration	0x10	no	0x10	no
0x155	SPI_TX	SPI Byte to Transmit	0x00	no	0x00	no
0x156	SPI_EXE	SPI Command Execute	0x00	no	0x00	no

0x200	PARTID	Customer Revision Information	0x00	no	Various	no
0x201	SYS_FAULT1	System Fault 1 Status	0x01	no	0x01	no
0x202	SYS_FAULT2	System Fault 2 Status	0x00	no	0x00	no
0x203	SYS_FAULT3	IC System Fault 3 Status	0x00	no	0x00	no
0x204	DEV_STAT	Device Status	0x00	no	0x00	no
0x205	LOOP_STAT	Round Robin Status	0x00	no	0x00	no
0x206	FAULT_SUMMARY	Fault Summary	0x00	no	0x00	no
0x207	VCELL1_HF	Cell 1 Voltage High Byte (Low Pass Filtered)	0x80	no	0x80	no
0x208	VCELL1_LF	Cell 1 Voltage Low Byte (Low Pass Filtered)	0x00	no	0x00	no
0x209	VCELL2_HF	Cell 2 Voltage High Byte (Low Pass Filtered)	0x80	no	0x80	no
0x20A	VCELL2_LF	Cell 2 Voltage Low Byte (Low Pass Filtered)	0x00	no	0x00	no
0x20B	VCELL3_HF	Cell 3 Voltage High Byte (Low Pass Filtered)	0x80	no	0x80	no
0x20C	VCELL3_LF	Cell 3 Voltage Low Byte (Low Pass Filtered)	0x00	no	0x00	no
0x20D	VCELL4_HF	Cell 4 Voltage High Byte (Low Pass Filtered)	0x80	no	0x80	no
0x20E	VCELL4_LF	Cell 4 Voltage Low Byte (Low Pass Filtered)	0x00	no	0x00	no
0x20F	VCELL5_HF	Cell 5 Voltage High Byte (Low Pass Filtered)	0x80	no	0x80	no
0x210	VCELL5_LF	Cell 5 Voltage Low Byte (Low Pass Filtered)	0x00	no	0x00	no
0x211	VCELL6_HF	Cell 6 Voltage High Byte (Low Pass Filtered)	0x80	no	0x80	no
0x212	VCELL6_LF	Cell 6 Voltage Low Byte (Low Pass Filtered)	0x00	no	0x00	no
0x213	CONV_CNTH	Cell ADC Conversion Counter High Byte	0x00	no	0x00	no
0x214	CONV_CNTL	Cell ADC Conversion Counter Low Byte	0x00	no	0x00	no
0x215	VCELL1H	Cell 1 Voltage High Byte (Corrected)	0x80	no	0x80	no
0x216	VCELL1L	Cell 1 Voltage Low Byte (Corrected)	0x00	no	0x00	no
0x217	VCELL2H	Cell 2 Voltage High Byte (Corrected)	0x80	no	0x80	no
0x218	VCELL2L	Cell 2 Voltage Low Byte (Corrected)	0x00	no	0x00	no
0x219	VCELL3H	Cell 3 Voltage High Byte (Corrected)	0x80	no	0x80	no
0x21A	VCELL3L	Cell 3 Voltage Low Byte (Corrected)	0x00	no	0x00	no
0x21B	VCELL4H	Cell 4 Voltage High Byte (Corrected)	0x80	no	0x80	no

0x21C	VCELL4L	Cell 4 Voltage Low Byte (Corrected)	0x00	no	0x00	no
0x21D	VCELL5H	Cell 5 Voltage High Byte (Corrected)	0x80	no	0x80	no
0x21E	VCELL5L	Cell 5 Voltage Low Byte (Corrected)	0x00	no	0x00	no
0x21F	VCELL6H	Cell 6 Voltage High Byte (Corrected)	0x80	no	0x80	no
0x220	VCELL6L	Cell 6 Voltage Low Byte (Corrected)	0x00	no	0x00	no
0x221	VCELL_FACTCORRH	Selected Cell Factory Corrected High Byte	0x80	no	0x80	no
0x222	VCELL_FACTCORRL	Selected Cell Factory Corrected Low Byte	0x00	no	0x00	no
0x223	AUX_CELLH	AUX Cell Measurement Voltage Low Byte	0x80	no	0x80	no
0x224	AUX_CELLL	AUX Cell Measurement Voltage Low Byte	0x00	no	0x00	no
0x225	AUX_BATH	Cell Stack Voltage High (Corrected)	0x80	no	0x80	no
0x226	AUX_BATL	Cell Stack Voltage Low (Corrected)	0x00	no	0x00	no
0x227	AUX_REF2H	Bandgap 1 Voltage Output High Byte	0x80	no	0x80	no
0x228	AUX_REF2L	Bandgap 1 Voltage Output Low Byte	0x00	no	0x00	no
0x229	AUX_ZEROH	ZERO Reference Voltage High Byte	0x80	no	0x80	no
0x22A	AUX_ZEROL	ZERO Reference Voltage Low Byte	0x00	no	0x00	no
0x22B	AUX_AVDDH	AVDD LDO Voltage Output	0x80	no	0x80	no
0x22C	AUX_AVDDL	AVDD LDO Voltage Output Low Byte	0x00	no	0x00	no
0x22D	AUX_GPIO1H	GPIO1 Voltage High (Corrected)	0x80	no	0x80	no
0x22E	AUX_GPIO1L	GPIO1 Voltage Low (Corrected)	0x00	no	0x00	no
0x22F	AUX_GPIO2H	GPIO2 Voltage High (Corrected)	0x80	no	0x80	no
0x230	AUX_GPIO2L	GPIO2 Voltage Low (Corrected)	0x00	no	0x00	no
0x231	AUX_GPIO3H	GPIO3 Voltage High (Corrected)	0x80	no	0x80	no
0x232	AUX_GPIO3L	GPIO3 Voltage Low (Corrected)	0x00	no	0x00	no
0x233	AUX_GPIO4H	GPIO4 Voltage High (Corrected)	0x80	no	0x80	no
0x234	AUX_GPIO4L	GPIO4 Voltage Low (Corrected)	0x00	no	0x00	no
0x235	AUX_GPIO5H	GPIO5 Voltage High (Corrected)	0x80	no	0x80	no
0x236	AUX_GPIO5L	GPIO5 Voltage Low (Corrected)	0x00	no	0x00	no
0x237	AUX_GPIO6H	GPIO6 Voltage High (Corrected)	0x80	no	0x80	no
0x238	AUX_GPIO6L	GPIO6 Voltage Low (Corrected)	0x00	no	0x00	no
0x239	AUX_FACTCORRH	Selected GPIO Factory Corrected High Byte	0x80	no	0x80	no

0x23A	AUX_FACTCORRL	Selected GPIO Factory Corrected Low Byte	0x00	no	0x00	no
0x23B	DIE_TEMP_H	Die Junction Temperature High Byte	0x80	no	0x80	no
0x23C	DIE_TEMP_L	Die Junction Temperature Low Byte	0x00	no	0x00	no
0x23D	AUX_REF3_H	Bandgap 2 Voltage Output High Byte	0x80	no	0x80	no
0x23E	AUX_REF3_L	Bandgap 2 Voltage Output Low Byte	0x00	no	0x00	no
0x23F	AUX_OV_DACH	OV Reference Voltage High Byte	0x80	no	0x80	no
0x240	AUX_OV_DACL	OV Reference Voltage Low Byte	0x00	no	0x00	no
0x241	AUX_UV_DACH	UV Reference Voltage High Byte	0x80	no	0x80	no
0x242	AUX_UV_DACL	UV Reference Voltage Low Byte	0x00	no	0x00	no
0x243	AUX_OT_DACH	OT Reference Voltage High Byte	0x80	no	0x80	no
0x244	AUX_OT_DACL	OT Reference Voltage Low Byte	0x00	no	0x00	no
0x245	AUX_UT_DACH	UT Reference Voltage High Byte	0x80	no	0x80	no
0x246	AUX_UT_DACL	UT Reference Voltage Low Byte	0x00	no	0x00	no
0x247	AUX_TWARN_PTAT_H	TWARN PTAT Current High Byte	0x80	no	0x80	no
0x248	AUX_TWARN_PTAT_L	TWARN PTAT Current Low Byte	0x00	no	0x00	no
0x249	AUX_DVDDH	DVDD LDO Voltage Output High Byte	0x80	no	0x80	no
0x24A	AUX_DVDDL	DVDD LDO Voltage Output Low Byte	0x00	no	0x00	no
0x24B	AUX_TSREFH	TSREF Voltage Output High Byte	0x80	no	0x80	no
0x24C	AUX_TSREFL	TSREF Voltage Output Low Byte	0x00	no	0x00	no
0x24D	AUX_CVDDH	CVDD LDO Voltage Output High Byte	0x80	no	0x80	no
0x24E	AUX_CVDDL	CVDD LDO Voltage Output Low Byte	0x00	no	0x00	no
0x24F	AUX_AVAO_REFH	AVAO_REF Reference Voltage High Byte	0x80	no	0x80	no
0x250	AUX_AVAO_REFL	AVAO_REF Reference Voltage Low Byte	0x00	no	0x00	no
0x260	SPI_RX	SPI Byte Read	0x00	no	0x00	no
0x261	CB_DONE	Cell Balancing Complete Status	0x00	no	0x00	no
0x262	GPIO_STAT	GPIO Input Status	0x00	no	0x00	no
0x263	CBVC_COMP_STAT	CBVC Comparator Status	0x00	no	0x00	no
0x264	CBVC_VCLOW_STAT	CBVC VCLOW Comparator Status	0x00	no	0x00	no
0x265	COMM_UART_RC_STAT3	Discarded UART Command Frame Counter	0x00	no	0x00	no
0x266	COMM_COML_RC_STAT3	Discarded COML Command Frame Counter	0x00	no	0x00	no

0x267	COMM_COMH_RR_STAT3	Discarded COMH Response Frame Counter	0x00	no	0x00	no
0x268	COMM_COML_RR_STAT3	Discarded COML Response Frame Counter	0x00	no	0x00	no
0x269	COMM_COMH_RC_STAT3	Discarded COMH Command Frame Counter	0x00	no	0x00	no
0x26A	COMM_UART_RR_STAT3	Discarded UART Response Frame Counter	0x00	no	0x00	no
0x26B	COMM_UART_RC_STAT1	Valid UART Command Frame Counter High Byte	0x00	no	0x00	no
0x26C	COMM_UART_RC_STAT2	Valid UART Command Frame Counter Low Byte	0x00	no	0x00	no
0x26D	COMM_COML_RC_STAT1	Valid COML Command Frame Counter High Byte	0x00	no	0x00	no
0x26E	COMM_COML_RC_STAT2	Valid COML Command Frame Counter Low Byte	0x00	no	0x00	no
0x26F	COMM_COMH_RR_STAT1	Valid COMH Response Frame Counter High Byte	0x00	no	0x00	no
0x270	COMM_COMH_RR_STAT2	Valid COMH Response Frame Counter Low Byte	0x00	no	0x00	no
0x271	COMM_UART_TR_STAT1	Transmitted UART Response Frame Counter High Byte	0x00	no	0x00	no
0x272	COMM_UART_TR_STAT2	Transmitted UART Response Frame Counter Low Byte	0x00	no	0x00	no
0x273	COMM_COML_TR_STAT1	Transmitted COML Response Frame Counter High Byte	0x00	no	0x00	no
0x274	COMM_COML_TR_STAT2	Transmitted COML Response Frame Counter Low Byte	0x00	no	0x00	no
0x275	COMM_COMH_RC_STAT1	Valid COMH Command Frame Counter High Byte	0x00	no	0x00	no
0x276	COMM_COMH_RC_STAT2	Valid COMH Command Frame Counter Low Byte	0x00	no	0x00	no
0x277	COMM_COML_RR_STAT1	Valid COML Response Frame Counter High Byte	0x00	no	0x00	no
0x278	COMM_COML_RR_STAT2	Valid COML Response Frame Counter Low Byte	0x00	no	0x00	no
0x279	COMM_COMH_TR_STAT1	Transmitted COMH Response Frame Counter High Byte	0x00	no	0x00	no
0x27A	COMM_COMH_TR_STAT2	Transmitted COMH Response Frame Counter Low Byte	0x00	no	0x00	no
0x27B	COMM_UART_RR_STAT1	Valid UART Response Frame Counter High Byte	0x00	no	0x00	no
0x27C	COMM_UART_RR_STAT2	Valid UART Response Frame Counter Low Byte	0x00	no	0x00	no
0x27D	OTP_PROG_STAT	OTP Programming Status	0x00	no	0x00	no

0x27E	OTP_CUST1_STAT1	Customer OTP Page 1 Status	0x01	no	0x01	no
0x27F	OTP_CUST1_STAT2	Customer OTP Page 1 Programming Status	0x00	no	0x00	no
0x280	OTP_CUST2_STAT1	Customer OTP Page 2 Status	0x01	no	0x01	no
0x281	OTP_CUST2_STAT2	Customer OTP Page 2 Programming Status	0x00	no	0x00	no
0x282	CB_SW_STAT	Cell Balancing Switch Status	0x00	no	0x00	no
0x290	GPIO_FAULT	GPIO Fault Status	0x00	no	0x00	no
0x291	UV_FAULT	UV Comparator Fault Status	0x00	no	0x00	no
0x292	OV_FAULT	OV Comparator Fault Status	0x00	no	0x00	no
0x293	UT_FAULT	UT Comparator Fault Status	0x00	no	0x00	no
0x294	OT_FAULT	OT Comparator Fault Status	0x00	no	0x00	no
0x295	TONE_FAULT	FAULT Bus Status	0x00	no	0x00	no
0x296	COMM_UART_FAULT	UART Fault Status	0x00	no	0x00	no
0x297	COMM_UART_RC_FAULT	UART Receive Command Fault Status	0x00	no	0x00	no
0x298	COMM_UART_RR_FAULT	UART Receive Response Fault Status (only valid in multidrop mode)	0x00	no	0x00	no
0x299	COMM_UART_TR_FAULT	UART Transmit Fault Status	0x00	no	0x00	no
0x29A	COMM_COMH_FAULT	COMH Fault Status	0x00	no	0x00	no
0x29B	COMM_COMH_RC_FAULT	COMH Receive Command Fault Status	0x00	no	0x00	no
0x29C	COMM_COMH_RR_FAULT	COMH Receive Response Fault Status	0x00	no	0x00	no
0x29D	COMM_COMH_TR_FAULT	COMH Transmit Fault Status	0x00	no	0x00	no
0x29E	COMM_COML_FAULT	COML Fault Status	0x00	no	0x00	no
0x29F	COMM_COML_RC_FAULT	COML Receive Command Fault Status	0x00	no	0x00	no
0x2A0	COMM_COML_RR_FAULT	COML Receive Response Fault Status	0x00	no	0x00	no
0x2A1	COMM_COML_TR_FAULT	COML Transmit Fault Status	0x00	no	0x00	no
0x2A2	OTP_FAULT	OTP Page Fault Status	0x00	no	0x00	no
0x2A3	RAIL_FAULT	Power Rail Fault Status	0x01	no	0x01	no
0x2A4	OVUV_BIST_FAULT	OVUV BIST Fault Status	0x00	no	0x00	no
0x2A5	OTUT_BIST_FAULT	OTUT BIST Fault Status	0x00	no	0x00	no
0x2B0	ECC_DATAOUT0	1st Data Out Byte for ECC Test	0x00	no	0x00	no
0x2B1	ECC_DATAOUT1	2nd Data Out Byte for ECC Test	0x00	no	0x00	no



0x2B2	ECC_DATAOUT2	3rd Data Out Byte for ECC Test	0x00	no	0x00	no
0x2B3	ECC_DATAOUT3	4th Data Out Byte for ECC Test	0x00	no	0x00	no
0x2B4	ECC_DATAOUT4	5th Data Out Byte for ECC Test	0x00	no	0x00	no
0x2B5	ECC_DATAOUT5	6th Data Out Byte for ECC Test	0x00	no	0x00	no
0x2B6	ECC_DATAOUT6	7th Data Out Byte for ECC Test	0x00	no	0x00	no
0x2B7	ECC_DATAOUT7	8th Data Out Byte for ECC Test	0x00	no	0x00	no
0x2B8	ECC_DATAOUT8	9th Data Out Byte for ECC Test	0x00	no	0x00	no
0x2B9	SEC_BLK	SEC Detected Block	0x00	no	0x00	no
0x2BA	DED_BLK	DED Detected Block	0x00	no	0x00	no
0x2BB	DEV_ADD_STAT	Device Address Status	0x00	no	0x01	no
0x2BC	COMM_STAT	Communication Status Register	0x00	no	0x01	no
0x2BD	DAISY_CHAIN_STAT	Communication Status Register	0x00	no	0x01	no
0x2C0	VCELL1_HU	Cell 1 Voltage High Byte (Uncorrected)	0x80	no	0x80	no
0x2C1	VCELL1_MU	Cell 1 Voltage Middle Byte (Uncorrected)	0x00	no	0x00	no
0x2C2	VCELL1_LU	Cell 1 Voltage Low Byte (Uncorrected)	0x00	no	0x00	no
0x2C3	VCELL2_HU	Cell 2 Voltage High Byte (Uncorrected)	0x80	no	0x80	no
0x2C4	VCELL2_MU	Cell 2 Voltage Middle Byte (Uncorrected)	0x00	no	0x00	no
0x2C5	VCELL2_LU	Cell 2 Voltage Low Byte (Uncorrected)	0x00	no	0x00	no
0x2C6	VCELL3_HU	Cell 3 Voltage High Byte (Uncorrected)	0x80	no	0x80	no
0x2C7	VCELL3_MU	Cell 3 Voltage Middle Byte (Uncorrected)	0x00	no	0x00	no
0x2C8	VCELL3_LU	Cell 3 Voltage Low Byte (Uncorrected)	0x00	no	0x00	no
0x2C9	VCELL4_HU	Cell 4 Voltage High Byte (Uncorrected)	0x80	no	0x80	no
0x2CA	VCELL4_MU	Cell 4 Voltage Middle Byte (Uncorrected)	0x00	no	0x00	no
0x2CB	VCELL4_LU	Cell 4 Voltage Low Byte (Uncorrected)	0x00	no	0x00	no
0x2CC	VCELL5_HU	Cell 5 Voltage High (Uncorrected)	0x80	no	0x80	no
0x2CD	VCELL5_MU	Cell 5 Voltage Middle Byte (Uncorrected)	0x00	no	0x00	no
0x2CE	VCELL5_LU	Cell 5 Voltage Low Byte (Uncorrected)	0x00	no	0x00	no
0x2CF	VCELL6_HU	Cell 6 Voltage High Byte (Uncorrected)	0x80	no	0x80	no
0x2D0	VCELL6_MU	Cell 6 Voltage Middle Byte (Uncorrected)	0x00	no	0x00	no
0x2D1	VCELL6_LU	Cell 6 Voltage Low Byte (Uncorrected)	0x00	no	0x00	no
0x2D2	AUX_BAT_HU	Cell Stack Voltage High (Uncorrected)	0x80	no	0x80	no

0x2D3	AUX_BAT_LU	Cell Stack Voltage Low(Uncorrected)	0x00	no	0x00	no
0x2D4	AUX_GPIO1_HU	GPIO1 Voltage High (Uncorrected)	0x80	no	0x80	no
0x2D5	AUX_GPIO1_MU	GPIO1 Voltage Middle Byte (Uncorrected)	0x00	no	0x00	no
0x2D6	AUX_GPIO1_LU	GPIO1 Voltage Low (Uncorrected)	0x00	no	0x00	no
0x2D7	AUX_GPIO2_HU	GPIO2 Voltage High (Uncorrected)	0x80	no	0x80	no
0x2D8	AUX_GPIO2_LU	GPIO2 Voltage Low (Uncorrected)	0x00	no	0x00	no
0x2D9	AUX_GPIO3_HU	GPIO3 Voltage High (Uncorrected)	0x80	no	0x80	no
0x2DA	AUX_GPIO3_LU	GPIO3 Voltage Low (Uncorrected)	0x00	no	0x00	no
0x2DB	AUX_GPIO4_HU	GPIO4 Voltage High (Uncorrected)	0x80	no	0x80	no
0x2DC	AUX_GPIO4_LU	GPIO4 Voltage Low (Uncorrected)	0x00	no	0x00	no
0x2DD	AUX_GPIO5_HU	GPIO5 Voltage High (Uncorrected)	0x80	no	0x80	no
0x2DE	AUX_GPIO5_LU	GPIO5 Voltage Low (Uncorrected)	0x00	no	0x00	no
0x2DF	AUX_GPIO6_HU	GPIO6 Voltage High (Uncorrected)	0x80	no	0x80	no
0x2E0	AUX_GPIO6_LU	GPIO6 Voltage Low Byte (Uncorrected)	0x00	no	0x00	no
0x2E1	CUST_CRC_RSLTH	Calculated Customer CRC Result High Byte	Various	no	Various	no
0x2E2	CUST_CRC_RSLTL	Calculated Customer CRC Result Low Byte	Various	no	Various	no

### 8.6.1.2 Register: DEVADD\_OTP

DEVADD_OTP Register Address: 0x00							
B7	B6	B5	B4	B3	B2	B1	B0
SPARE[1]	SPARE[0]	ADD[5]	ADD[4]	ADD[3]	ADD[2]	ADD[1]	ADD[0]
0	0	0	0	0	0	0	0
RW	RW	RW	RW	RW	RW	RW	RW
SPARE[1:0]		spare					
ADD[5:0]		Programmable Default for Device Stack Address. These bits define the default startup address for the device. They are writeable anytime with no effect, they are only loaded when coming out of a RESET condition. See the "Device Addressing" section for more details. DEV_ADD_STAT Reflects the current device address.					

### 8.6.1.3 Register: CONFIG

CONFIG Register Address: 0x01							
B7	B6	B5	B4	B3	B2	B1	B0
SPARE[3]	SPARE[2]	SPARE[1]	SPARE[0]	MULTIDROP_EN	GPIO_ADD_SEL	STACK_DEV	TOP_STACK
0	0	0	0	0	0	0	0
RW	RW	RW	RW	RW	RW	RW	RW
SPARE[3:0]		spare					
MULTIDROP_EN	Defines stack configuration as daisy chain or multi-drop. 0: Daisy chain or base only configuration 1: Multi-drop configuration						
GPIO_ADD_SEL	Enables GPIO address mode 0: Use normal auto addressing mode. 1: Sample enabled GPIOs to obtain address.						
STACK_DEV	Defines device as a base or stack device 0: Base Device 1: Stack Device						
TOP_STACK	Defines device as highest addressed device in the stack. 0: Device is not the top of the stack 1: Device is defined as the top of the stack. Does not wait for device address N+1 to respond before sending a response packet.						

### 8.6.1.4 Register: GPIO\_FLT\_MSK

GPIO_FLT_MSK Register Address: 0x02							
B7	B6	B5	B4	B3	B2	B1	B0
SPARE[1]	SPARE[0]	GPIO6_MSK	GPIO5_MSK	GPIO4_MSK	GPIO3_MSK	GPIO2_MSK	GPIO1_MSK
0	0	0	0	0	0	0	0
RW	RW	RW	RW	RW	RW	RW	RW
SPARE[1:0]		spare					
GPIO6_MSK	Enables mask for GPIO_FAULT[GPIO6] 0: Mask disabled 1: Mask enabled to prevent fault signaling						
GPIO5_MSK	Enables mask for GPIO_FAULT[GPIO5] 0: Mask disabled 1: Mask enabled to prevent fault signaling						
GPIO4_MSK	Enables mask for GPIO_FAULT[GPIO4] 0: Mask disabled 1: Mask enabled to prevent fault signaling						
GPIO3_MSK	Enables mask for GPIO_FAULT[GPIO3] 0: Mask disabled 1: Mask enabled to prevent fault signaling						
GPIO2_MSK	Enables mask for GPIO_FAULT[GPIO2] 0: Mask disabled 1: Mask enabled to prevent fault signaling						
GPIO1_MSK	Enables mask for GPIO_FAULT[GPIO1] 0: Mask disabled 1: Mask enabled to prevent fault signaling						

### 8.6.1.5 Register: UV\_FLT\_MSK

UV_FLT_MSK Register Address: 0x03							
B7	B6	B5	B4	B3	B2	B1	B0
SPARE[1]	SPARE[0]	CELL6_MSK	CELL5_MSK	CELL4_MSK	CELL3_MSK	CELL2_MSK	CELL1_MSK
0	0	0	0	0	0	0	0
RW	RW	RW	RW	RW	RW	RW	RW
SPARE[1:0]		spare					
CELL6_MSK	Enables mask for UV_FAULT[CELL6] 0: Mask disabled 1: Mask enabled to prevent fault signaling						
CELL5_MSK	Enables mask for UV_FAULT[CELL5] 0: Mask disabled 1: Mask enabled to prevent fault signaling						
CELL4_MSK	Enables mask for UV_FAULT[CELL4] 0: Mask disabled 1: Mask enabled to prevent fault signaling						
CELL3_MSK	Enables mask for UV_FAULT[CELL3] 0: Mask disabled 1: Mask enabled to prevent fault signaling						
CELL2_MSK	Enables mask for UV_FAULT[CELL2] 0: Mask disabled 1: Mask enabled to prevent fault signaling						
CELL1_MSK	Enables mask for UV_FAULT[CELL1] 0: Mask disabled 1: Mask enabled to prevent fault signaling						

### 8.6.1.6 Register: OV\_FLT\_MSK

OV_FLT_MSK Register Address: 0x04							
B7	B6	B5	B4	B3	B2	B1	B0
SPARE[1]	SPARE[0]	CELL6_MSK	CELL5_MSK	CELL4_MSK	CELL3_MSK	CELL2_MSK	CELL1_MSK
0	0	0	0	0	0	0	0
RW	RW	RW	RW	RW	RW	RW	RW
SPARE[1:0]		spare					
CELL6_MSK	Enables mask for OV_FAULT[CELL6] 0: Mask disabled 1: Mask enabled to prevent fault signaling						
CELL5_MSK	Enables mask for OV_FAULT[CELL5] 0: Mask disabled 1: Mask enabled to prevent fault signaling						
CELL4_MSK	Enables mask for OV_FAULT[CELL4] 0: Mask disabled 1: Mask enabled to prevent fault signaling						
CELL3_MSK	Enables mask for OV_FAULT[CELL3] 0: Mask disabled 1: Mask enabled to prevent fault signaling						
CELL2_MSK	Enables mask for OV_FAULT[CELL2] 0: Mask disabled 1: Mask enabled to prevent fault signaling						
CELL1_MSK	Enables mask for OV_FAULT[CELL1] 0: Mask disabled 1: Mask enabled to prevent fault signaling						

### 8.6.1.7 Register: UT\_FLT\_MSK

UT_FLT_MSK Register Address: 0x05							
B7	B6	B5	B4	B3	B2	B1	B0
SPARE[1]	SPARE[0]	GPIO6_MSK	GPIO5_MSK	GPIO4_MSK	GPIO3_MSK	GPIO2_MSK	GPIO1_MSK
0	0	0	0	0	0	0	0
RW	RW	RW	RW	RW	RW	RW	RW
SPARE[1:0]		spare					
GPIO6_MSK		Enables mask for UT_FAULT[GPIO6] 0: Mask disabled 1: Mask enabled to prevent fault signaling					
GPIO5_MSK		Enables mask for UT_FAULT[GPIO5] 0: Mask disabled 1: Mask enabled to prevent fault signaling					
GPIO4_MSK		Enables mask for UT_FAULT[GPIO4] 0: Mask disabled 1: Mask enabled to prevent fault signaling					
GPIO3_MSK		Enables mask for UT_FAULT[GPIO3] 0: Mask disabled 1: Mask enabled to prevent fault signaling					
GPIO2_MSK		Enables mask for UT_FAULT[GPIO2] 0: Mask disabled 1: Mask enabled to prevent fault signaling					
GPIO1_MSK		Enables mask for UT_FAULT[GPIO1] 0: Mask disabled 1: Mask enabled to prevent fault signaling					

### 8.6.1.8 Register: OT\_FLT\_MSK

OT_FLT_MSK Register Address: 0x06							
B7	B6	B5	B4	B3	B2	B1	B0
SPARE[1]	SPARE[0]	GPIO6_MSK	GPIO5_MSK	GPIO4_MSK	GPIO3_MSK	GPIO2_MSK	GPIO1_MSK
0	0	0	0	0	0	0	0
RW	RW	RW	RW	RW	RW	RW	RW
SPARE[1:0]		spare					
GPIO6_MSK		Enables mask for OT_FAULT[GPIO6] 0: Mask disabled 1: Mask enabled to prevent fault signaling					
GPIO5_MSK		Enables mask for OT_FAULT[GPIO5] 0: Mask disabled 1: Mask enabled to prevent fault signaling					
GPIO4_MSK		Enables mask for OT_FAULT[GPIO4] 0: Mask disabled 1: Mask enabled to prevent fault signaling					
GPIO3_MSK		Enables mask for OT_FAULT[GPIO3] 0: Mask disabled 1: Mask enabled to prevent fault signaling					
GPIO2_MSK		Enables mask for OT_FAULT[GPIO2] 0: Mask disabled 1: Mask enabled to prevent fault signaling					
GPIO1_MSK		Enables mask for OT_FAULT[GPIO1] 0: Mask disabled 1: Mask enabled to prevent fault signaling					

### 8.6.1.9 Register: **TONE\_FLT\_MSK**

TONE_FLT_MSK Register Address: 0x07							
B7	B6	B5	B4	B3	B2	B1	B0
SPARE[4]	SPARE[3]	SPARE[2]	SPARE[1]	SPARE[0]	FF_REC_MSK	HB_FAIL_MSK	HB_FAST_MSK
0	0	0	0	0	0	0	0
RW	RW	RW	RW	RW	RW	RW	RW
SPARE[4:0]		spare					
FF_REC_MSK	Enables mask for TONE_FAULT[FF_REC] 0: Mask disabled 1: Mask enabled to prevent fault signaling						
HB_FAIL_MSK	Enables mask for TONE_FAULT[HB_FAIL] 0: Mask disabled 1: Mask enabled to prevent fault signaling						
HB_FAST_MSK	Enables mask for TONE_FAULT[HB_FAST] 0: Mask disabled 1: Mask enabled to prevent fault signaling						

### 8.6.1.10 Register: **COMM\_UART\_FLT\_MSK**

COMM_UART_FLT_MSK Register Address: 0x08							
B7	B6	B5	B4	B3	B2	B1	B0
SPARE[4]	SPARE[3]	SPARE[2]	SPARE[1]	SPARE[0]	COMMCLR_MSK	COMMRST_MSK	STOP_MSK
0	0	0	0	0	0	0	0
RW	RW	RW	RW	RW	RW	RW	RW
SPARE[4:0]		spare					
COMMCLR_MSK	Enables mask for COMM_UART_FAULT[COMMCLR_DET] 0: Mask disabled 1: Mask enabled to prevent fault signaling						
COMMRST_MSK	Enables mask for COMM_UART_FAULT[COMMRST_DET] 0: Mask disabled 1: Mask enabled to prevent fault signaling						
STOP_MSK	Enables mask for COMM_UART_FAULT[STOP] 0: Mask disabled 1: Mask enabled to prevent fault signaling						

### 8.6.1.11 Register: **COMM\_UART\_RC\_FLT\_MSK**

COMM_UART_RC_FLT_MSK Register Address: 0x09							
B7	B6	B5	B4	B3	B2	B1	B0
SPARE[1]	SPARE[0]	IERR_MSK	TXDIS_MSK	SOF_MSK	BERR_MSK	UNEXP_MSK	CRC_MSK
0	0	0	0	0	0	0	0
RW	RW	RW	RW	RW	RW	RW	RW
SPARE[1:0]		Spare					
IERR_MSK	Enables mask for COMM_UART_RC_FAULT[IERR] 0: Mask disabled 1: Mask enabled to prevent fault signaling						
TXDIS_MSK	Enables mask for COMM_UART_RC_FAULT[TXDIS] 0: Mask disabled 1: Mask enabled to prevent fault signaling						
SOF_MSK	Enables mask for COMM_UART_RC_FAULT[SOF] 0: Mask disabled 1: Mask enabled to prevent fault signaling						
BERR_MSK	Enables mask for COMM_UART_RC_FAULT[BERR] 0: Mask disabled 1: Mask enabled to prevent fault signaling						
UNEXP_MSK	Enables mask for COMM_UART_RC_FAULT[UNEXP] 0: Mask disabled 1: Mask enabled to prevent fault signaling						
CRC_MSK	Enables mask for COMM_UART_RC_FAULT[CRC] 0: Mask disabled 1: Mask enabled to prevent fault signaling						

### 8.6.1.12 Register: COMM\_UART\_RR\_FLT\_MSK

COMM_UART_RR_FLT_MSK Register Address: 0x0A							
B7	B6	B5	B4	B3	B2	B1	B0
SPARE[1]	SPARE[0]	SPARE	SPARE	SOF_MSK	BERR_MSK	SPARE	CRC_MSK
0	0	0	0	0	0	0	0
RW	RW	RW	RW	RW	RW	RW	RW
SPARE[1:0]	Spare						
SPARE	Spare						
SPARE	Spare						
SOF_MSK	Enables mask for COMM_UART_RR_FAULT[SOF] 0: Mask disabled 1: Mask enabled to prevent fault signaling						
BERR_MSK	Enables mask for COMM_UART_RR_FAULT[BERR] 0: Mask disabled 1: Mask enabled to prevent fault signaling						
SPARE	Spare						
CRC_MSK	Enables mask for COMM_UART_RR_FAULT[CRC] 0: Mask disabled 1: Mask enabled to prevent fault signaling						

### 8.6.1.13 Register: COMM\_UART\_TR\_FLT\_MSK

COMM_UART_TR_FLT_MSK Register Address: 0x0B							
B7	B6	B5	B4	B3	B2	B1	B0
SPARE[5]	SPARE[4]	SPARE[3]	SPARE[2]	SPARE[1]	SPARE[0]	SOF_MSK	WAIT_MSK
0	0	0	0	0	0	0	0
RW	RW	RW	RW	RW	RW	RW	RW
SPARE[5:0]	Spare						
SOF_MSK	Enables mask for COMM_UART_TR_FAULT[SOF] 0: Mask disabled 1: Mask enabled to prevent fault signaling						
WAIT_MSK	Enables mask for COMM_UART_TR_FAULT[WAIT] 0: Mask disabled 1: Mask enabled to prevent fault signaling						

### 8.6.1.14 Register: COMM\_COMH\_FLT\_MSK

COMM_COMH_FLT_MSK Register Address: 0x0C							
B7	B6	B5	B4	B3	B2	B1	B0
SPARE[1]	SPARE[0]	BERR_MSK	DATA_MISS_MSK	DATA_ORDER_MSK	SYNC2_MSK	SYNC1_MSK	BIT_MSK
0	0	0	0	0	0	0	0
RW	RW	RW	RW	RW	RW	RW	RW
SPARE[1:0]	Spare						
BERR_MSK	Enables mask for COMM_COMH_FAULT[BERR] 0: Mask disabled 1: Mask enabled to prevent fault signaling						
DATA_MISS_MSK	Enables mask for COMM_COMH_FAULT[DATA_MISS] 0: Mask disabled 1: Mask enabled to prevent fault signaling						
DATA_ORDER_MSK	Enables mask for COMM_COMH_FAULT[DATA_ORDER] 0: Mask disabled 1: Mask enabled to prevent fault signaling						
SYNC2_MSK	Enables mask for COMM_COMH_FAULT[SYNC2] 0: Mask disabled 1: Mask enabled to prevent fault signaling						
SYNC1_MSK	Enables mask for COMM_COMH_FAULT[SYNC1] 0: Mask disabled 1: Mask enabled to prevent fault signaling						
BIT_MSK	Enables mask for COMM_COMH_FAULT[BIT] 0: Mask disabled 1: Mask enabled to prevent fault signaling						



**8.6.1.15 Register: COMM\_COMH\_RC\_FLT\_MSK**

COMM_COMH_RC_FLT_MSK Register Address: 0x0D							
B7	B6	B5	B4	B3	B2	B1	B0
SPARE[1]	SPARE[0]	IERR_MSK	TXDIS_MSK	SOF_MSK	BERR_MSK	UNEXP_MSK	CRC_MSK
0	0	0	0	0	0	0	0
RW	RW	RW	RW	RW	RW	RW	RW
SPARE[1:0]		Spare					
IERR_MSK	Enables mask for COMM_COMH_RC_FAULT[IERR] 0: Mask disabled 1: Mask enabled to prevent fault signaling						
TXDIS_MSK	Enables mask for COMM_COMH_RC_FAULT[TXDIS] 0: Mask disabled 1: Mask enabled to prevent fault signaling						
SOF_MSK	Enables mask for COMM_COMH_RC_FAULT[SOF] 0: Mask disabled 1: Mask enabled to prevent fault signaling						
BERR_MSK	Enables mask for COMM_COMH_RC_FAULT[BERR] 0: Mask disabled 1: Mask enabled to prevent fault signaling						
UNEXP_MSK	Enables mask for COMM_COMH_RC_FAULT[UNEXP] 0: Mask disabled 1: Mask enabled to prevent fault signaling						
CRC_MSK	Enables mask for COMM_COMH_RC_FAULT[CRC] 0: Mask disabled 1: Mask enabled to prevent fault signaling						

**8.6.1.16 Register: COMM\_COMH\_RR\_FLT\_MSK**

COMM_COMH_RR_FLT_MSK Register Address: 0x0E							
B7	B6	B5	B4	B3	B2	B1	B0
SPARE[1]	SPARE[0]	SPARE	TXDIS_MSK	SOF_MSK	BERR_MSK	UNEXP_MSK	CRC_MSK
0	0	0	0	0	0	0	0
RW	RW	RW	RW	RW	RW	RW	RW
SPARE[1:0]		Spare					
SPARE		Spare					
TXDIS_MSK	Enables mask for COMM_COMH_RR_FAULT[TXDIS] 0: Mask disabled 1: Mask enabled to prevent fault signaling						
SOF_MSK	Enables mask for COMM_COMH_RR_FAULT[SOF] 0: Mask disabled 1: Mask enabled to prevent fault signaling						
BERR_MSK	Enables mask for COMM_COMH_RR_FAULT[BERR] 0: Mask disabled 1: Mask enabled to prevent fault signaling						
UNEXP_MSK	Enables mask for COMM_COMH_RR_FAULT[UNEXP] 0: Mask disabled 1: Mask enabled to prevent fault signaling						
CRC_MSK	Enables mask for COMM_COMH_RR_FAULT[CRC] 0: Mask disabled 1: Mask enabled to prevent fault signaling						

**8.6.1.17 Register: COMM\_COMH\_TR\_FLT\_MSK**

COMM_COMH_TR_FLT_MSK Register Address: 0x0F							
B7	B6	B5	B4	B3	B2	B1	B0
SPARE[5]	SPARE[4]	SPARE[3]	SPARE[2]	SPARE[1]	SPARE[0]	SPARE	WAIT_MSK
0	0	0	0	0	0	0	0
RW	RW	RW	RW	RW	RW	RW	RW
SPARE[5:0]		Spare					
SPARE		Spare					
WAIT_MSK	Enables mask for COMM_COMH_TR_FAULT[WAIT] 0: Mask disabled 1: Mask enabled to prevent fault signaling						

**8.6.1.18 Register: COMM\_COML\_FLT\_MSK**

COMM_COML_FLT_MSK Register Address: 0x10							
B7	B6	B5	B4	B3	B2	B1	B0
SPARE[1]	SPARE[0]	BERR_MSK	DATA_MISS_MSK	DATA_ORDER_MSK	SYNC2_MSK	SYNC1_MSK	BIT_MSK
0	0	0	0	0	0	0	0
RW	RW	RW	RW	RW	RW	RW	RW
SPARE[1:0]		Spare					
BERR_MSK		Enables mask for COMM_COML_FAULT[BERR] 0: Mask disabled 1: Mask enabled to prevent fault signaling					
DATA_MISS_MSK		Enables mask for COMM_COML_FAULT[DATA_MISS] 0: Mask disabled 1: Mask enabled to prevent fault signaling					
DATA_ORDER_MSK		Enables mask for COMM_COML_FAULT[DATA_ORDER] 0: Mask disabled 1: Mask enabled to prevent fault signaling					
SYNC2_MSK		Enables mask for COMM_COML_FAULT[SYNC2] 0: Mask disabled 1: Mask enabled to prevent fault signaling					
SYNC1_MSK		Enables mask for COMM_COML_FAULT[SYNC1] 0: Mask disabled 1: Mask enabled to prevent fault signaling					
BIT_MSK		Enables mask for COMM_COML_FAULT[BIT] 0: Mask disabled 1: Mask enabled to prevent fault signaling					

**8.6.1.19 Register: COMM\_COML\_RC\_FLT\_MSK**

COMM_COML_RC_FLT_MSK Register Address: 0x11							
B7	B6	B5	B4	B3	B2	B1	B0
SPARE[1]	SPARE[0]	IERR_MSK	TXDIS_MSK	SOF_MSK	BERR_MSK	UNEXP_MSK	CRC_MSK
0	0	0	0	0	0	0	0
RW	RW	RW	RW	RW	RW	RW	RW
SPARE[1:0]		Spare					
IERR_MSK		Enables mask for COMM_COML_RC_FAULT[IERR] 0: Mask disabled 1: Mask enabled to prevent fault signaling					
TXDIS_MSK		Enables mask for COMM_COML_RC_FAULT[TXDIS] 0: Mask disabled 1: Mask enabled to prevent fault signaling					
SOF_MSK		Enables mask for COMM_COML_RC_FAULT[SOF] 0: Mask disabled 1: Mask enabled to prevent fault signaling					
BERR_MSK		Enables mask for COMM_COML_RC_FAULT[BERR] 0: Mask disabled 1: Mask enabled to prevent fault signaling					
UNEXP_MSK		Enables mask for COMM_COML_RC_FAULT[UNEXP] 0: Mask disabled 1: Mask enabled to prevent fault signaling					
CRC_MSK		Enables mask for COMM_COML_RC_FAULT[CRC] 0: Mask disabled 1: Mask enabled to prevent fault signaling					

**8.6.1.20 Register: COMM\_COML\_RR\_FLT\_MSK**

COMM_COML_RR_FLT_MSK Register Address: 0x12							
B7	B6	B5	B4	B3	B2	B1	B0
SPARE[1]	SPARE[0]	SPARE	TXDIS_MSK	SOF_MSK	BERR_MSK	UNEXP_MSK	CRC_MSK
0	0	0	0	0	0	0	0
RW	RW	RW	RW	RW	RW	RW	RW
SPARE[1:0]	Spare						
SPARE	Spare						
TXDIS_MSK	Enables mask for COMM_COML_RR_FAULT[TXDIS] 0: Mask disabled 1: Mask enabled to prevent fault signaling						
SOF_MSK	Enables mask for COMM_COML_RR_FAULT[SOF] 0: Mask disabled 1: Mask enabled to prevent fault signaling						
BERR_MSK	Enables mask for COMM_COML_RR_FAULT[BERR] 0: Mask disabled 1: Mask enabled to prevent fault signaling						
UNEXP_MSK	Enables mask for COMM_COML_RR_FAULT[UNEXP] 0: Mask disabled 1: Mask enabled to prevent fault signaling						
CRC_MSK	Enables mask for COMM_COML_RR_FAULT[CRC] 0: Mask disabled 1: Mask enabled to prevent fault signaling						

**8.6.1.21 Register: COMM\_COML\_TR\_FLT\_MSK**

COMM_COML_TR_FLT_MSK Register Address: 0x13							
B7	B6	B5	B4	B3	B2	B1	B0
SPARE[5]	SPARE[4]	SPARE[3]	SPARE[2]	SPARE[1]	SPARE[0]	SPARE	WAIT_MSK
0	0	0	0	0	0	0	0
RW	RW	RW	RW	RW	RW	RW	RW
SPARE[5:0]	Spare						
SPARE	Spare						
WAIT_MSK	Enables mask for COMM_COML_TR_FAULT[WAIT] 0: Mask disabled 1: Mask enabled to prevent fault signaling						

**8.6.1.22 Register: OTP\_FLT\_MSK**

OTP_FLT_MSK Register Address: 0x14							
B7	B6	B5	B4	B3	B2	B1	B0
SPARE[4]	SPARE[3]	SPARE[2]	SPARE[1]	SPARE[0]	CUSTLDERR_M SK	FACTLDERR_MS K	GBLOVERR_MS K
0	0	0	0	0	0	0	0
RW	RW	RW	RW	RW	RW	RW	RW
SPARE[4:0]	Spare						
CUSTLDERR_M SK	Enables mask for OTP_FAULT[CUSTLDERR] 0: Mask disabled 1: Mask enabled to prevent fault signaling						
FACTLDERR_MS K	Enables mask for OTP_FAULT[FACTLDERR] 0: Mask disabled 1: Mask enabled to prevent fault signaling						
GBLOVERR_MS K	Enables mask for OTP_FAULT[GBLOVRERR] 0: Mask disabled 1: Mask enabled to prevent fault signaling						

### 8.6.1.23 Register: RAIL\_FLT\_MSK

RAIL_FLT_MSK Register Address: 0x15							
B7	B6	B5	B4	B3	B2	B1	B0
AVDDREFUV_MSK	TSREFOV_MSK	TSREFUV_MSK	VLDOOV_MSK	CVDDUV_MSK	DVDDOV_MSK	AVDDOV_MSK	AVDDUV_DRST_MSK
0	0	0	0	0	0	0	0
RW	RW	RW	RW	RW	RW	RW	RW
AVDDREFUV_MSK	Enables mask for RAIL_FAULT[AVDD_REFUV] 0: Mask disabled 1: Mask enabled to prevent fault signaling						
TSREFOV_MSK	Enables mask for RAIL_FAULT[TSREFOV] 0: Mask disabled 1: Mask enabled to prevent fault signaling						
TSREFUV_MSK	Enables mask for RAIL_FAULT[TSREFUV] 0: Mask disabled 1: Mask enabled to prevent fault signaling						
VLDOOV_MSK	Enables mask for RAIL_FAULT[VLDOOV] 0: Mask disabled 1: Mask enabled to prevent fault signaling						
CVDDUV_MSK	Enables mask for RAIL_FAULT[CVDDUV] 0: Mask disabled 1: Mask enabled to prevent fault signaling						
DVDDOV_MSK	Enables mask for RAIL_FAULT[DVDDOV] 0: Mask disabled 1: Mask enabled to prevent fault signaling						
AVDDOV_MSK	Enables mask for RAIL_FAULT[AVDDOV] 0: Mask disabled 1: Mask enabled to prevent fault signaling						
AVDDUV_DRST_MSK	Enables mask for RAIL_FAULT[AVDDUV_DRST] 0: Mask disabled 1: Mask enabled to prevent fault signaling						

### 8.6.1.24 Register: SYS\_FLT1\_FLT\_MSK

SYS_FLT1_FLT_MSK Register Address: 0x16							
B7	B6	B5	B4	B3	B2	B1	B0
SPARE	TWARN_MSK	Reserved	CTS_MSK	TSD_MSK	AVDD_REFUV_D_RST_MSK	AVAO_REF_OV_MSK	DRST_MSK
0	0	0	0	0	0	0	0
RW	RW	RW	RW	RW	RW	RW	RW
SPARE	Spare						
TWARN_MSK	Enables mask for SYS_FAULT1[TWARN] 0: Mask disabled 1: Mask enabled to prevent fault signaling						
Reserved	Reserved						
CTS_MSK	Enables mask for SYS_FAULT1[CTS] 0: Mask disabled 1: Mask enabled to prevent fault signaling						
TSD_MSK	Enables mask for SYS_FAULT1[TSD] 0: Mask disabled 1: Mask enabled to prevent fault signaling						
AVDD_REFUV_D_RST_MSK	Enables mask for SYS_FAULT1[AVDD_REFUV_DRST] 0: Mask disabled 1: Mask enabled to prevent fault signaling						
AVAO_REF_OV_MSK	Enables mask for SYS_FAULT1[AVAO_REF_OV] 0: Mask disabled 1: Mask enabled to prevent fault signaling						
DRST_MSK	Enables mask for SYS_FAULT1[DRST] 0: Mask disabled 1: Mask enabled to prevent fault signaling						

**8.6.1.25 Register: SYS\_FLT2\_FLT\_MSK**

SYS_FLT2_FLT_MSK Register Address: 0x17							
B7	B6	B5	B4	B3	B2	B1	B0
SHTDWN_REC_MSK	CVSS_OPEN_MSK	DVSS_OPEN_MSK	AVDD_OSC_MSK	TSREF_OSC_MSK	REF1_OSC_MSK	FACT_CRC_MSK	CUST_CRC_MSK
0	0	0	0	0	0	0	0
RW	RW	RW	RW	RW	RW	RW	RW
SHTDWN_REC_MSK	Enables mask for SYS_FAULT2[SHTDWN_REC] 0: Mask disabled 1: Mask enabled to prevent fault signaling						
CVSS_OPEN_MSK	Enables mask for SYS_FAULT2[CVSS_OPEN] 0: Mask disabled 1: Mask enabled to prevent fault signaling						
DVSS_OPEN_MSK	Enables mask for SYS_FAULT2[DVSS_OPEN] 0: Mask disabled 1: Mask enabled to prevent fault signaling						
AVDD_OSC_MSK	Enables mask for SYS_FAULT2[AVDD_OSC] 0: Mask disabled 1: Mask enabled to prevent fault signaling						
TSREF_OSC_MSK	Enables mask for SYS_FAULT2[TSREF_OSC] 0: Mask disabled 1: Mask enabled to prevent fault signaling						
REF1_OSC_MSK	Enables mask for SYS_FAULT2[REF1_OSC] 0: Mask disabled 1: Mask enabled to prevent fault signaling						
FACT_CRC_MSK	Enables mask for SYS_FAULT2[FACT_CRC] 0: Mask disabled 1: Mask enabled to prevent fault signaling						
CUST_CRC_MSK	Enables mask for SYS_FAULT2[CUST_CRC] 0: Mask disabled 1: Mask enabled to prevent fault signaling						

**8.6.1.26 Register: SYS\_FLT3\_FLT\_MSK**

SYS_FLT3_FLT_MSK Register Address: 0x18							
B7	B6	B5	B4	B3	B2	B1	B0
SPARE	AUX_FILTER_MSK	LP_FILTER_MSK	VIOUV_MSK	CB_VDONE_MSK	LFO_MSK	SEC_DET_MSK	DED_DET_MSK
0	0	0	0	0	0	0	0
RW	RW	RW	RW	RW	RW	RW	RW
SPARE	Spare						
AUX_FILTER_MSK	Enables mask for SYS_FAULT3[AUX_FILTER] 0: Mask disabled 1: Mask enabled to prevent fault signaling						
LP_FILTER_MSK	Enables mask for SYS_FAULT3[LP_FILTER] 0: Mask disabled 1: Mask enabled to prevent fault signaling						
VIOUV_MSK	Enables mask for SYS_FAULT3[VIOUV] 0: Mask disabled 1: Mask enabled to prevent fault signaling						
CB_VDONE_MSK	Enables mask for SYS_FAULT3[CB_VDONE] 0: Mask disabled 1: Mask enabled to prevent fault signaling						
LFO_MSK	Enables mask for SYS_FAULT3[LFO] 0: Mask disabled 1: Mask enabled to prevent fault signaling						
SEC_DET_MSK	Enables mask for SYS_FAULT3[SEC_DETECT] 0: Mask disabled 1: Mask enabled to prevent fault signaling						
DED_DET_MSK	Enables mask for SYS_FAULT3[DED_DETECT] 0: Mask disabled 1: Mask enabled to prevent fault signaling						

### 8.6.1.27 Register: OVUV\_BIST\_FLT\_MSK

OVUV_BIST_FLT_MSK Register Address: 0x19							
B7	B6	B5	B4	B3	B2	B1	B0
SPARE[5]	SPARE[4]	SPARE[3]	SPARE[2]	SPARE[1]	SPARE[0]	OVCOMP_MSK	UVCOMP_MSK
0	0	0	0	0	0	0	0
RW	RW	RW	RW	RW	RW	RW	RW
SPARE[5:0]		Spare					
OVCOMP_MSK	Enables mask for OVUV_BIST_FAULT[OVCOMP] 0: Mask disabled 1: Mask enabled to prevent fault signaling						
UVCOMP_MSK	Enables mask for OVUV_BIST_FAULT[UVCOMP] 0: Mask disabled 1: Mask enabled to prevent fault signaling						

### 8.6.1.28 Register: OTUT\_BIST\_FLT\_MSK

OTUT_BIST_FLT_MSK Register Address: 0x1A							
B7	B6	B5	B4	B3	B2	B1	B0
MUX6_MSK	MUX5_MSK	MUX4_MSK	MUX3_MSK	MUX2_MSK	MUX1_MSK	UTCOMP_MSK	OTCOMP_MSK
0	0	0	0	0	0	0	0
RW	RW	RW	RW	RW	RW	RW	RW
MUX6_MSK	Enables mask for OTUT_BIST_FAULT[MUX6] 0: Mask disabled 1: Mask enabled to prevent fault signaling						
MUX5_MSK	Enables mask for OTUT_BIST_FAULT[MUX5] 0: Mask disabled 1: Mask enabled to prevent fault signaling						
MUX4_MSK	Enables mask for OTUT_BIST_FAULT[MUX4] 0: Mask disabled 1: Mask enabled to prevent fault signaling						
MUX3_MSK	Enables mask for OTUT_BIST_FAULT[MUX3] 0: Mask disabled 1: Mask enabled to prevent fault signaling						
MUX2_MSK	Enables mask for OTUT_BIST_FAULT[MUX2] 0: Mask disabled 1: Mask enabled to prevent fault signaling						
MUX1_MSK	Enables mask for OTUT_BIST_FAULT[MUX1] 0: Mask disabled 1: Mask enabled to prevent fault signaling						
UTCOMP_MSK	Enables mask for OTUT_BIST_FAULT[UTCOMP] 0: Mask disabled 1: Mask enabled to prevent fault signaling						
OTCOMP_MSK	Enables mask for OTUT_BIST_FAULT[OTCOMP] 0: Mask disabled 1: Mask enabled to prevent fault signaling						

### 8.6.1.29 Register: SPARE\_01

SPARE_01 Register Address: 0x1B							
B7	B6	B5	B4	B3	B2	B1	B0
SPARE[7]	SPARE[6]	SPARE[5]	SPARE[4]	SPARE[3]	SPARE[2]	SPARE[1]	SPARE[0]
0	0	0	0	0	0	0	0
RW	RW	RW	RW	RW	RW	RW	RW
SPARE[7:0]		Spare , out of factory samples use this for corrected ADC channel corrected error value: b7,6,5,4 - VC1 HI; b4,3,2,1 - VC1 LO					

**8.6.1.30 Register: SPARE\_02**

SPARE_02 Register Address: 0x1C							
B7	B6	B5	B4	B3	B2	B1	B0
SPARE[7]	SPARE[6]	SPARE[5]	SPARE[4]	SPARE[3]	SPARE[2]	SPARE[1]	SPARE[0]
0	0	0	0	0	0	0	0
RW	RW	RW	RW	RW	RW	RW	RW
SPARE[7:0] Spare , out of factory samples use this for corrected ADC channel corrected error value: b7,6,5,4 - VC2 HI; b4,3,2,1 - VC2 LO							

**8.6.1.31 Register: SPARE\_03**

SPARE_03 Register Address: 0x1D							
B7	B6	B5	B4	B3	B2	B1	B0
SPARE[7]	SPARE[6]	SPARE[5]	SPARE[4]	SPARE[3]	SPARE[2]	SPARE[1]	SPARE[0]
0	0	0	0	0	0	0	0
RW	RW	RW	RW	RW	RW	RW	RW
SPARE[7:0] Spare , out of factory samples use this for corrected ADC channel corrected error value: b7,6,5,4 - VC3 HI; b4,3,2,1 - VC3 LO							

**8.6.1.32 Register: SPARE\_04**

SPARE_04 Register Address: 0x1E							
B7	B6	B5	B4	B3	B2	B1	B0
SPARE[7]	SPARE[6]	SPARE[5]	SPARE[4]	SPARE[3]	SPARE[2]	SPARE[1]	SPARE[0]
0	0	0	0	0	0	0	0
RW	RW	RW	RW	RW	RW	RW	RW
SPARE[7:0] Spare , out of factory samples use this for corrected ADC channel corrected error value: b7,6,5,4 - VC4 HI; b4,3,2,1 - VC4 LO							

**8.6.1.33 Register: SPARE\_05**

SPARE_05 Register Address: 0x1F							
B7	B6	B5	B4	B3	B2	B1	B0
SPARE[7]	SPARE[6]	SPARE[5]	SPARE[4]	SPARE[3]	SPARE[2]	SPARE[1]	SPARE[0]
0	0	0	0	0	0	0	0
RW	RW	RW	RW	RW	RW	RW	RW
SPARE[7:0] Spare , out of factory samples use this for corrected ADC channel corrected error value: b7,6,5,4 - VC5 HI; b4,3,2,1 - VC5 LO							



### 8.6.1.34 Register: COMM\_CTRL

COMM_CTRL Register Address: 0x20							
B7	B6	B5	B4	B3	B2	B1	B0
SPARE	TWO_STOP_EN	UARTTX_EN	NFAULT_EN	BAUD[1]	BAUD[0]	FAULT_TONE_EN	FAULT_HB_EN
0	0	1	1	0	1	0	0
RW		RW	RW	RW	RW	RW	RW
SPARE		Spare					
TWO_STOP_EN	Enables two stop bits for the UART interface in case of severe oscillator error in both the host and device. Setting this bit enables device to enter two stop bits when it transmits. This bit doesn't play any role for UART receiver. Host UART transmitter must ensure that it also inserts two stop bits along with setting this bit to truly take extend the oscillator variation. 0: One STOP bit 1: Two STOP bits						
UARTTX_EN	Enables UART transmitter. 0: Disabled. No responses are sent from TX regardless of read requests. 1: Enabled						
NFAULT_EN	Enables the NFAULT function. 0: Disabled. NFAULT always pulled up to VIO. 1: Enabled. NFAULT pulls low to indicate unmasked faults.						
BAUD[1:0]	Selects baud rate for UART interface. This bit should not be affected by communication reset. The baud rate of the device is reflected in COMM_STAT[BAUD_STAT]. 00: 125kbps 01: 250kbps 10: 500kbps 11: 1Mbps						
FAULT_TONE_EN	Enables fault tone transmit function on FAULT bus. When fault is enabled, make sure the FAULT TX and RX are enabled too, DAISY_CHAIN_CTRL[FAULTRX_EN] and DAISY_CHAIN_CTRL[FAULTTX_EN]. 0: Disabled 1: Enabled						
FAULT_HB_EN	Enables heartbeat transmit function on FAULT bus. When heartbeat is enabled, make sure the FAULT TX and RX are enabled too, DAISY_CHAIN_CTRL[FAULTRX_EN] and DAISY_CHAIN_CTRL[FAULTTX_EN]. 0: Disabled 1: Enabled						

### 8.6.1.35 Register: DAISY\_CHAIN\_CTRL

DAISY_CHAIN_CTRL Register Address: 0x21							
B7	B6	B5	B4	B3	B2	B1	B0
SPARE[1]	SPARE[0]	COMLTX_EN	COMLRX_EN	COMHTX_EN	COMHRX_EN	FAULTTX_EN	FAULTRX_EN
0	0	1	1	1	1	0	0
RW	RW	RW	RW	RW	RW	RW	RW
SPARE[1:0]		Spare					
COMLTX_EN	Enables COML transmitter. Note that COMLTX_EN=0 can not be done through broadcast write. This has to be handled by doing individual write to DaisyChainCtrl register, one by one starting from Top Most device instead of attempting a broadcast write. Refer to the tables of the "Daisy Chain Transmitter and Receiver Functionality" section for more details. 0: Disabled 1: Enabled						
COMLRX_EN	Enables COML receiver. Refer to the "Daisy Chain Transmitter and Receiver Functionality" section for more details. Do not disable the RX COMH and COML at the same time, otherwise device cannot communicate through daisy chain via its low interface. 0: Disables 1: Enables						
COMHTX_EN	Enables COMH transmitter. Note that COMHTX_EN=0 can not be done through broadcast write. This has to be handled by doing individual write to DaisyChainCtrl register, one by one starting from Top Most device instead of attempting a broadcast write. Refer to the tables of the "Daisy Chain Transmitter and Receiver Functionality" section for more details 0: Disabled 1: Enabled						
COMHRX_EN	Enables COMH receiver. Refer to the tables of the "Daisy Chain Transmitter and Receiver Functionality" section for more details. Do not disable the RX COMH and COML at the same time, otherwise device cannot communicate through daisy chain via its high interface. 0: Disables 1: Enables						
FAULTTX_EN	Enables FAULTL transmitter 0: Disabled 1: Enabled						
FAULTRX_EN	Enables FAULTH receiver 0: Disabled 1: Enabled						

**8.6.1.36 Register: TX\_HOLD\_OFF**

TX_HOLD_OFF Register Address: 0x22							
B7	B6	B5	B4	B3	B2	B1	B0
DLY[7]	DLY[6]	DLY[5]	DLY[4]	DLY[3]	DLY[2]	DLY[1]	DLY[0]
0	0	0	0	0	0	0	0
RW	RW	RW	RW	RW	RW	RW	RW

DLY[7:0] Programs number of bit periods (0 to 255) after receiving a STOP bit before the transmitter transmits data.

**8.6.1.37 Register: COMM\_TO**

COMM_TO Register Address: 0x23							
B7	B6	B5	B4	B3	B2	B1	B0
SPARE	SHORT[2]	SHORT[1]	SHORT[0]	Reserved.	LONG[2]	LONG[1]	LONG[0]
0	0	0	0	0	0	0	0
RW	RW	RW	RW	RW	RW	RW	RW

SPARE Spare

SHORT[2:0] Programs the short communication timeout. When this timeout expires, the SYS\_FAULT1[CTS] bit is set.  
 000 Short communication timeout disabled  
 001: 0.1s  
 010: 2s  
 011: 10s  
 100: 1min  
 101: 10min  
 110: 30min  
 111: 1hour

Reserved. Reserved. Do not write to this bit. If a full register needs to be written, make sure this bit is always 1.

LONG[2:0] Programs the long communication timeout. When this timeout expires, the device goes to shut down.  
 000: Long communication timeout disabled  
 001: 0.1s  
 010: 2s  
 011: 10s  
 100: 1min  
 101: 10min  
 110: 30min  
 111: 1hour

**8.6.1.38 Register: CELL\_ADC\_CONF1**

CELL_ADC_CONF1 Register Address: 0x24							
B7	B6	B5	B4	B3	B2	B1	B0
SPARE	DR[1]	DR[0]	ADC_FREQ[1]	ADC_FREQ[0]	FILSHIFT[2]	FILSHIFT[1]	FILSHIFT[0]
0	1	1	0	0	0	0	0
RW	RW	RW	RW	RW	RW	RW	RW

SPARE Spare

DR[1:0] Sets decimation ratio for ADC (applies to all cell and DIETEMP ADCs)  
 00: 32  
 01: 64  
 10: 128  
 11: 256

ADC\_FREQ[1:0] Selects ADC sample frequency (applies to all cell and DIETEMP ADCs)  
 00: 1 MHz  
 01: Reserved (1MHz operation)  
 10: Reserved (1MHz operation)  
 11: Reserved (1MHz operation)

FILSHIFT[2:0] Selects first order ADC lowpass filter corner frequency (frequencies only valid for ADC\_CONF1[ADC\_FREQ]=00 and ADC\_CONF1[DR]=11). See "Digital RC Corner Frequencies" table for other DR settings in "Single Pole Digital Filter" section  
 000: 180.1 Hz  
 001: 83.1 Hz  
 010: 40.1 Hz  
 011: 19.7 HZ  
 100: 9.8 Hz  
 101: 4.9 Hz  
 110: 2.4 Hz  
 111: 1.2 Hz

### 8.6.1.39 Register: CELL\_ADC\_CONF2

CELL_ADC_CONF2 Register Address: 0x25							
B7	B6	B5	B4	B3	B2	B1	B0
SPARE[3]	SPARE[2]	SPARE[1]	SPARE[0]	CELL_CONT	CELL_INT[2]	CELL_INT[1]	CELL_INT[0]
0	0	0	0	0	1	1	1
RW	RW	RW	RW	RW	RW	RW	RW
SPARE[3:0]		Spare					
CELL_CONT		Enables continuous conversions for CELL and DIETEMP ADCs 0: Single conversion done when CONTROL2[ADC_GO] is set 1: Continuous conversions enabled when ADC_GO is set					
CELL_INT[2:0]		Sets the conversion interval for the cell and DIETEMP ADCs when continuous conversions is enabled 000: Minimum timing (starts directly after registers updated) 001: 1ms 010: 5ms 011: 10ms 100: 50ms 101: 100ms 110: 500ms 111: 1s					

### 8.6.1.40 Register: AUX\_ADC\_CONF

AUX_ADC_CONF Register Address: 0x26							
B7	B6	B5	B4	B3	B2	B1	B0
SPARE[3]	SPARE[2]	SPARE[1]	SPARE[0]	DR[1]	DR[0]	ADC_FREQ[1]	ADC_FREQ[0]
0	0	0	0	1	1	0	0
RW	RW	RW	RW	RW	RW	RW	RW
SPARE[3:0]		Spare					
DR[1:0]		Sets decimation ratio for ADC 00: 32 01: 64 10: 128 11: 256					
ADC_FREQ[1:0]		Selects ADC sample frequency (applies to all ADCs) 00: 1 MHz 01: Reserved (1MHz operation) 10: Reserved (1MHz operation) 11: Reserved (1MHz operation)					

### 8.6.1.41 Register: ADC\_DELAY

ADC_DELAY Register Address: 0x27							
B7	B6	B5	B4	B3	B2	B1	B0
SPARE[2]	SPARE[1]	SPARE[0]	DLY[4]	DLY[3]	DLY[2]	DLY[1]	DLY[0]
0	0	0	0	0	0	0	0
RW	RW	RW	RW	RW	RW	RW	RW
SPARE[2:0]		Spare					
DLY[4:0]		Sets the delay from CONTROL2[CELL_ADCGO]=1 or CONTROL2[AUX_ADCGO]=1 to ADC conversion start. This is added to delay to the built-in time delays. ADC_DELAY[DLY] is used to synchronized voltage measurements to an external current measurement or to synchronize the small delays between the devices in the stack. Programmable from 0us to 155us with 5us step size.					

**8.6.1.42 Register: GPIO\_ADC\_CONF**

GPIO_ADC_CONF Register Address: 0x28							
B7	B6	B5	B4	B3	B2	B1	B0
SPARE[1]	SPARE[0]	GPIOCONF6	GPIOCONF5	GPIOCONF4	GPIOCONF3	GPIOCONF2	GPIOCONF1
0	0	0	0	0	0	0	0
RW	RW	RW	RW	RW	RW	RW	RW
SPARE[1:0]		Spare					
GPIOCONF6		Configures ADC result for GPIO6 as ratiometric or an absolute measurement 0: Temperature sensor monitor (ratiometric result) 1: AUX voltage measurement (absolute voltage result)					
GPIOCONF5		Configures ADC result for GPIO5 as ratiometric or an absolute measurement 0: Temperature sensor monitor (ratiometric result) 1: AUX voltage measurement (absolute voltage result)					
GPIOCONF4		Configures ADC result for GPIO4 as ratiometric or an absolute measurement 0: Temperature sensor monitor (ratiometric result) 1: AUX voltage measurement (absolute voltage result)					
GPIOCONF3		Configures ADC result for GPIO3 as ratiometric or an absolute measurement 0: Temperature sensor monitor (ratiometric result) 1: AUX voltage measurement (absolute voltage result)					
GPIOCONF2		Configures ADC result for GPIO2 as ratiometric or an absolute measurement 0: Temperature sensor monitor (ratiometric result) 1: AUX voltage measurement (absolute voltage result)					
GPIOCONF1		Configures ADC result for GPIO1 as ratiometric or an absolute measurement 0: Temperature sensor monitor (ratiometric result) 1: AUX voltage measurement (absolute voltage result)					

**8.6.1.43 Register: OVUV\_CTRL**

OVUV_CTRL Register Address: 0x29							
B7	B6	B5	B4	B3	B2	B1	B0
SPARE[1]	SPARE[0]	CELL6_EN	CELL5_EN	CELL4_EN	CELL3_EN	CELL2_EN	CELL1_EN
0	0	0	0	0	0	0	0
RW	RW	RW	RW	RW	RW	RW	RW
SPARE[1:0]		Spare					
CELL6_EN		Enables OV and UV comparators for CELL6 0: Disabled 1: Enabled					
CELL5_EN		Enables OV and UV comparators for CELL5 0: Disabled 1: Enabled					
CELL4_EN		Enables OV and UV comparators for CELL4 0: Disabled 1: Enabled					
CELL3_EN		Enables OV and UV comparators for CELL3 0: Disabled 1: Enabled					
CELL2_EN		Enables OV and UV comparators for CELL2 0: Disabled 1: Enabled					
CELL1_EN		Enables OV and UV comparators for CELL1 0: Disabled 1: Enabled					

**8.6.1.44 Register: UV\_THRESH**

UV_THRESH Register Address: 0x2A							
B7	B6	B5	B4	B3	B2	B1	B0
SPARE	THRESH[6]	THRESH[5]	THRESH[4]	THRESH[3]	THRESH[2]	THRESH[1]	THRESH[0]
0	1	1	0	0	0	0	0
RW	RW	RW	RW	RW	RW	RW	RW
SPARE		Spare					
THRESH[6:0]		Under-voltage threshold Programmable from 0.7V to 3.875V with 25mV step size					

### 8.6.1.45 Register: OV\_THRESH

OV_THRESH Register Address: 0x2B							
B7	B6	B5	B4	B3	B2	B1	B0
SPARE	THRESH[6]	THRESH[5]	THRESH[4]	THRESH[3]	THRESH[2]	THRESH[1]	THRESH[0]
0	1	1	0	0	0	0	0
RW	RW	RW	RW	RW	RW	RW	RW
SPARE	Spare						
THRESH[6:0]	Over-voltage threshold Programmable from 2V to 5V with 25mV step size. Codes 0b1111000 - 0b1111111 all result in the 5V threshold.						

### 8.6.1.46 Register: OTUT\_CTRL

OTUT_CTRL Register Address: 0x2C							
B7	B6	B5	B4	B3	B2	B1	B0
SPARE[1]	SPARE[0]	GPIO6_EN	GPIO5_EN	GPIO4_EN	GPIO3_EN	GPIO2_EN	GPIO1_EN
0	0	0	0	0	0	0	0
RW	RW	RW	RW	RW	RW	RW	RW
SPARE[1:0]	Spare						
GPIO6_EN	Enables GPIO6 over-temperature and under-temperature hardware protection. 0: Disabled 1: Enabled						
GPIO5_EN	Enables GPIO5 over-temperature and under-temperature hardware protection. 0: Disabled 1: Enabled						
GPIO4_EN	Enables GPIO4 over-temperature and under-temperature hardware protection. 0: Disabled 1: Enabled						
GPIO3_EN	Enables GPIO3 over-temperature and under-temperature hardware protection. 0: Disabled 1: Enabled						
GPIO2_EN	Enables GPIO2 over-temperature and under-temperature hardware protection. 0: Disabled 1: Enabled						
GPIO1_EN	Enables GPIO1 over-temperature and under-temperature hardware protection. 0: Disabled 1: Enabled						

### 8.6.1.47 Register: OTUT\_THRESH

OTUT_THRESH Register Address: 0x2D							
B7	B6	B5	B4	B3	B2	B1	B0
OT_THRESH[3]	OT_THRESH[2]	OT_THRESH[1]	OT_THRESH[0]	UT_THRESH[3]	UT_THRESH[2]	UT_THRESH[1]	UT_THRESH[0]
0	0	0	0	0	0	0	0
RW	RW	RW	RW	RW	RW	RW	RW
OT_THRESH[3:0]	GPIO1-GPIO6 over-temperature threshold Programmable from 20% to 35% of TSREF with 1% step size						
UT_THRESH[3:0]	GPIO1-GPIO6 under-temperature threshold Programmable from 60% to 75% of TSREF with 1% step size						

**8.6.1.48 Register: COMP\_DG**

COMP_DG Register Address: 0x2E							
B7	B6	B5	B4	B3	B2	B1	B0
SPARE[3]	SPARE[2]	SPARE[1]	SPARE[0]	TEMP_DG[1]	TEMP_DG[0]	OVUV_DG[1]	OVUV_DG[0]
0	0	0	0	0	0	0	0
RW	RW	RW	RW	RW	RW	RW	RW
SPARE[3:0]		Spare					
TEMP_DG[1:0]		Over/ Under-temperature comparator deglitch timer. 00: 25µs 01: 50µs 10: 100µs 11: 500µs					
OVUV_DG[1:0]		Over/Under-voltage and CBDONE comparator deglitch timer. 00: 25µs 01: 50µs 10: 100µs 11: 500µs					

**8.6.1.49 Register: GPIO1\_CONF**

GPIO1_CONF Register Address: 0x2F							
B7	B6	B5	B4	B3	B2	B1	B0
SPARE	ADD_SEL	GPIO_SEL	PUPD_SEL[2]	PUPD_SEL[1]	PUPD_SEL[0]	FLT_EN[1]	FLT_EN[0]
0	0	1	1	0	0	0	0
RW	RW	RW	RW	RW	RW	RW	RW
SPARE		Spare					
ADD_SEL		Configures GPIO1 as an address input 0: Not used to configure address 1: Used to configure address					
GPIO_SEL		Configure GPIO1 as output/ input 0: Configured as output 1: Configured as input					
PUPD_SEL[2:0]		Configures GPIO1 pullup and pulldown 000: Analog Input (no pullup/pulldown, used for ADC applications only) 001: Reserved 010: Weak pullup resistor 011: Reserved 100: Weak pulldown resistor (used in input mode only) 101: Push-Pull (used in output mode only) 110 - 111: Reserved					
FLT_EN[1:0]		Configures GPIO1 fault behavior 00: Does not signal fault 01: Signals fault when low 10: Signals fault when high 11: Reserved					

### 8.6.1.50 Register: GPIO2\_CONF

GPIO2_CONF Register Address: 0x30							
B7	B6	B5	B4	B3	B2	B1	B0
SPARE	ADD_SEL	GPIO_SEL	PUPD_SEL[2]	PUPD_SEL[1]	PUPD_SEL[0]	FLT_EN[1]	FLT_EN[0]
0	0	1	1	0	0	0	0
RW	RW	RW	RW	RW	RW	RW	RW
SPARE	Spare						
ADD_SEL	Configures GPIO2 as an address input 0: Not used to configure address 1: Used to configure address						
GPIO_SEL	Configure GPIO2 as output/ input 0: Configured as output 1: Configured as input						
PUPD_SEL[2:0]	Configures GPIO2 pullup and pulldown 000: Analog Input (no pullup/pulldown, used for ADC applications only) 001: Reserved 010: Weak pullup resistor 011: Reserved 100: Weak pulldown resistor (used in input mode only) 101: Push-Pull (used in output mode only) 110 - 111: Reserved						
FLT_EN[1:0]	Configures GPIO2 fault behavior 00: Does not signal fault 01: Signals fault when low 10: Signals fault when high 11: Reserved						

### 8.6.1.51 Register: GPIO3\_CONF

GPIO3_CONF Register Address: 0x31							
B7	B6	B5	B4	B3	B2	B1	B0
SPARE	ADD_SEL	GPIO_SEL	PUPD_SEL[2]	PUPD_SEL[1]	PUPD_SEL[0]	FAULT_EN[1]	FAULT_EN[0]
0	0	1	1	0	0	0	0
RW	RW	RW	RW	RW	RW	RW	RW
SPARE	Spare						
ADD_SEL	Configures GPIO3 as an address input 0: Not used to configure address 1: Used to configure address						
GPIO_SEL	Configure GPIO3 as output/ input 0: Configured as output 1: Configured as input						
PUPD_SEL[2:0]	Configures GPIO3 pullup and pulldown 000: Analog Input (no pullup/pulldown, used for ADC applications only) 001: Reserved 010: Weak pullup resistor 011: Reserved 100: Weak pulldown resistor (used in input mode only) 101: Push-Pull (used in output mode only) 110 - 111: Reserved						
FAULT_EN[1:0]	Configures GPIO3 fault behavior 00: Does not signal fault 01: Signals fault when low 10: Signals fault when high 11: Reserved						



**8.6.1.52 Register: GPIO4\_CONF**

GPIO4_CONF Register Address: 0x32							
B7	B6	B5	B4	B3	B2	B1	B0
SPARE	ADD_SEL	GPIO_SEL	PUPD_SEL[2]	PUPD_SEL[1]	PUPD_SEL[0]	FAULT_EN[1]	FAULT_EN[0]
0	0	1	1	0	0	0	0
RW	RW	RW	RW	RW	RW	RW	RW
SPARE	Spare						
ADD_SEL	Configures GPIO4 as an address input 0: Not used to configure address 1: Used to configure address						
GPIO_SEL	Configure GPIO4 as output/ input 0: Configured as output 1: Configured as input						
PUPD_SEL[2:0]	Configures GPIO4 pullup and pulldown 000: Analog Input (no pullup/pulldown, used for ADC applications only) 001: Reserved 010: Weak pullup resistor 011: Reserved 100: Weak pulldown resistor (used in input mode only) 101: Push-Pull (used in output mode only) 110 - 111: Reserved						
FAULT_EN[1:0]	Configures GPIO4 fault behavior 00: Does not signal fault 01: Signals fault when low 10: Signals fault when high 11: Reserved						

**8.6.1.53 Register: GPIO5\_CONF**

GPIO5_CONF Register Address: 0x33							
B7	B6	B5	B4	B3	B2	B1	B0
SPARE	ADD_SEL	GPIO_SEL	PUPD_SEL[2]	PUPD_SEL[1]	PUPD_SEL[0]	FAULT_EN[1]	FAULT_EN[0]
0	0	1	1	0	0	0	0
RW	RW	RW	RW	RW	RW	RW	RW
SPARE	Spare						
ADD_SEL	Configures GPIO5 as an address input 0: Not used to configure address 1: Used to configure address						
GPIO_SEL	Configure GPIO5 as output/ input 0: Configured as output 1: Configured as input						
PUPD_SEL[2:0]	Configures GPIO5 pullup and pulldown 000: Analog Input (no pullup/pulldown, used for ADC applications only) 001: Reserved 010: Weak pullup resistor 011: Reserved 100: Weak pulldown resistor (used in input mode only) 101: Push-Pull (used in output mode only) 110 - 111: Reserved						
FAULT_EN[1:0]	Configures GPIO5 fault behavior 00: Does not signal fault 01: Signals fault when low 10: Signals fault when high 11: Reserved						

**8.6.1.54 Register: GPIO6\_CONF**

GPIO6_CONF Register Address: 0x34							
B7	B6	B5	B4	B3	B2	B1	B0
SPARE	ADD_SEL	GPIO_SEL	PUPD_SEL[2]	PUPD_SEL[1]	PUPD_SEL[0]	FAULT_EN[1]	FAULT_EN[0]
0	0	1	1	0	0	0	0
RW	RW	RW	RW	RW	RW	RW	RW
SPARE		Spare					
ADD_SEL		Configures GPIO6 as an address input 0: Not used to configure address 1: Used to configure address					
GPIO_SEL		Configure GPIO6 as output/ input 0: Configured as output 1: Configured as input					
PUPD_SEL[2:0]		Configures GPIO6 pullup and pulldown 000: Analog Input (no pullup/pulldown, used for ADC applications only) 001: Reserved 010: Weak pullup resistor 011: Reserved 100: Weak pulldown resistor (used in input mode only) 101: Push-Pull (used in output mode only) 110 - 111: Reserved					
FAULT_EN[1:0]		Configures GPIO6 fault behavior 00: Does not signal fault 01: Signals fault when low 10: Signals fault when high 11: Reserved					

**8.6.1.55 Register: CELL1\_GAIN**

CELL1_GAIN Register Address: 0x35							
B7	B6	B5	B4	B3	B2	B1	B0
GAIN[7]	GAIN[6]	GAIN[5]	GAIN[4]	GAIN[3]	GAIN[2]	GAIN[1]	GAIN[0]
0	0	0	0	0	0	0	0
RW	RW	RW	RW	RW	RW	RW	RW
GAIN[7:0]		Cell 1 Gain Calibration					

**8.6.1.56 Register: CELL2\_GAIN**

CELL2_GAIN Register Address: 0x36							
B7	B6	B5	B4	B3	B2	B1	B0
GAIN[7]	GAIN[6]	GAIN[5]	GAIN[4]	GAIN[3]	GAIN[2]	GAIN[1]	GAIN[0]
0	0	0	0	0	0	0	0
RW	RW	RW	RW	RW	RW	RW	RW
GAIN[7:0]		Cell 2 Gain Calibration					

**8.6.1.57 Register: CELL3\_GAIN**

CELL3_GAIN Register Address: 0x37							
B7	B6	B5	B4	B3	B2	B1	B0
GAIN[7]	GAIN[6]	GAIN[5]	GAIN[4]	GAIN[3]	GAIN[2]	GAIN[1]	GAIN[0]
0	0	0	0	0	0	0	0
RW	RW	RW	RW	RW	RW	RW	RW
GAIN[7:0]		Cell 3 Gain Calibration					

**8.6.1.58 Register: CELL4\_GAIN**

CELL4_GAIN Register Address: 0x38							
B7	B6	B5	B4	B3	B2	B1	B0
GAIN[7]	GAIN[6]	GAIN[5]	GAIN[4]	GAIN[3]	GAIN[2]	GAIN[1]	GAIN[0]
0	0	0	0	0	0	0	0
RW	RW	RW	RW	RW	RW	RW	RW
GAIN[7:0] Cell 4 Gain Calibration							

**8.6.1.59 Register: CELL5\_GAIN**

CELL5_GAIN Register Address: 0x39							
B7	B6	B5	B4	B3	B2	B1	B0
GAIN[7]	GAIN[6]	GAIN[5]	GAIN[4]	GAIN[3]	GAIN[2]	GAIN[1]	GAIN[0]
0	0	0	0	0	0	0	0
RW	RW	RW	RW	RW	RW	RW	RW
GAIN[7:0] Cell 5 Gain Calibration							

**8.6.1.60 Register: CELL6\_GAIN**

CELL6_GAIN Register Address: 0x3A							
B7	B6	B5	B4	B3	B2	B1	B0
GAIN[7]	GAIN[6]	GAIN[5]	GAIN[4]	GAIN[3]	GAIN[2]	GAIN[1]	GAIN[0]
0	0	0	0	0	0	0	0
RW	RW	RW	RW	RW	RW	RW	RW
GAIN[7:0] Cell 6 Gain Calibration							

**8.6.1.61 Register: CELL1\_OFF**

CELL1_OFF Register Address: 0x3B							
B7	B6	B5	B4	B3	B2	B1	B0
OFFSET[7]	OFFSET[6]	OFFSET[5]	OFFSET[4]	OFFSET[3]	OFFSET[2]	OFFSET[1]	OFFSET[0]
0	0	0	0	0	0	0	0
RW	RW	RW	RW	RW	RW	RW	RW
OFFSET[7:0] Cell 1 Offset Calibration							

**8.6.1.62 Register: CELL2\_OFF**

CELL2_OFF Register Address: 0x3C							
B7	B6	B5	B4	B3	B2	B1	B0
OFFSET[7]	OFFSET[6]	OFFSET[5]	OFFSET[4]	OFFSET[3]	OFFSET[2]	OFFSET[1]	OFFSET[0]
0	0	0	0	0	0	0	0
RW	RW	RW	RW	RW	RW	RW	RW
OFFSET[7:0] Cell 2 Offset Calibration							

**8.6.1.63 Register: CELL3\_OFF**

CELL3_OFF Register Address: 0x3D							
B7	B6	B5	B4	B3	B2	B1	B0
OFFSET[7]	OFFSET[6]	OFFSET[5]	OFFSET[4]	OFFSET[3]	OFFSET[2]	OFFSET[1]	OFFSET[0]
0	0	0	0	0	0	0	0
RW	RW	RW	RW	RW	RW	RW	RW
OFFSET[7:0] Cell 3 Offset Calibration							

**8.6.1.64 Register: CELL4\_OFF**

CELL4_OFF Register Address: 0x3E							
B7	B6	B5	B4	B3	B2	B1	B0
OFFSET[7]	OFFSET[6]	OFFSET[5]	OFFSET[4]	OFFSET[3]	OFFSET[2]	OFFSET[1]	OFFSET[0]
0	0	0	0	0	0	0	0
RW	RW	RW	RW	RW	RW	RW	RW
OFFSET[7:0] Cell 4 Offset Calibration							

**8.6.1.65 Register: CELL5\_OFF**

CELL5_OFF Register Address: 0x3F							
B7	B6	B5	B4	B3	B2	B1	B0
OFFSET[7]	OFFSET[6]	OFFSET[5]	OFFSET[4]	OFFSET[3]	OFFSET[2]	OFFSET[1]	OFFSET[0]
0	0	0	0	0	0	0	0
RW	RW	RW	RW	RW	RW	RW	RW
OFFSET[7:0] Cell 5 Offset Calibration							

**8.6.1.66 Register: CELL6\_OFF**

CELL6_OFF Register Address: 0x40							
B7	B6	B5	B4	B3	B2	B1	B0
OFFSET[7]	OFFSET[6]	OFFSET[5]	OFFSET[4]	OFFSET[3]	OFFSET[2]	OFFSET[1]	OFFSET[0]
0	0	0	0	0	0	0	0
RW	RW	RW	RW	RW	RW	RW	RW
OFFSET[7:0] Cell 6 Offset Calibration							

**8.6.1.67 Register: GPIO1\_GAIN**

GPIO1_GAIN Register Address: 0x41							
B7	B6	B5	B4	B3	B2	B1	B0
GAIN[7]	GAIN[6]	GAIN[5]	GAIN[4]	GAIN[3]	GAIN[2]	GAIN[1]	GAIN[0]
0	0	0	0	0	0	0	0
RW	RW	RW	RW	RW	RW	RW	RW
GAIN[7:0] GPIO1 Gain Calibration							

**8.6.1.68 Register: GPIO2\_GAIN**

GPIO2_GAIN Register Address: 0x42							
B7	B6	B5	B4	B3	B2	B1	B0
GAIN[7]	GAIN[6]	GAIN[5]	GAIN[4]	GAIN[3]	GAIN[2]	GAIN[1]	GAIN[0]
0	0	0	0	0	0	0	0
RW	RW	RW	RW	RW	RW	RW	RW
GAIN[7:0] GPIO2 Gain Calibration							

**8.6.1.69 Register: GPIO3\_GAIN**

GPIO3_GAIN Register Address: 0x43							
B7	B6	B5	B4	B3	B2	B1	B0
GAIN[7]	GAIN[6]	GAIN[5]	GAIN[4]	GAIN[3]	GAIN[2]	GAIN[1]	GAIN[0]
0	0	0	0	0	0	0	0
RW	RW	RW	RW	RW	RW	RW	RW
GAIN[7:0] GPIO3 Gain Calibration							

**8.6.1.70 Register: GPIO4\_GAIN**

GPIO4_GAIN Register Address: 0x44							
B7	B6	B5	B4	B3	B2	B1	B0
GAIN[7]	GAIN[6]	GAIN[5]	GAIN[4]	GAIN[3]	GAIN[2]	GAIN[1]	GAIN[0]
0	0	0	0	0	0	0	0
RW	RW	RW	RW	RW	RW	RW	RW
GAIN[7:0] GPIO4 Gain Calibration							

**8.6.1.71 Register: GPIO5\_GAIN**

GPIO5_GAIN Register Address: 0x45							
B7	B6	B5	B4	B3	B2	B1	B0
GAIN[7]	GAIN[6]	GAIN[5]	GAIN[4]	GAIN[3]	GAIN[2]	GAIN[1]	GAIN[0]
0	0	0	0	0	0	0	0
RW	RW	RW	RW	RW	RW	RW	RW
GAIN[7:0] GPIO5 Gain Calibration							

**8.6.1.72 Register: GPIO6\_GAIN**

GPIO6_GAIN Register Address: 0x46							
B7	B6	B5	B4	B3	B2	B1	B0
GAIN[7]	GAIN[6]	GAIN[5]	GAIN[4]	GAIN[3]	GAIN[2]	GAIN[1]	GAIN[0]
0	0	0	0	0	0	0	0
RW	RW	RW	RW	RW	RW	RW	RW
GAIN[7:0] GPIO6 Gain Calibration							

**8.6.1.73 Register: GPIO1\_OFF**

GPIO1_OFF Register Address: 0x47							
B7	B6	B5	B4	B3	B2	B1	B0
OFFSET[7]	OFFSET[6]	OFFSET[5]	OFFSET[4]	OFFSET[3]	OFFSET[2]	OFFSET[1]	OFFSET[0]
0	0	0	0	0	0	0	0
RW	RW	RW	RW	RW	RW	RW	RW
OFFSET[7:0] GPIO1 Offset Calibration							

**8.6.1.74 Register: GPIO2\_OFF**

GPIO2_OFF Register Address: 0x48							
B7	B6	B5	B4	B3	B2	B1	B0
OFFSET[7]	OFFSET[6]	OFFSET[5]	OFFSET[4]	OFFSET[3]	OFFSET[2]	OFFSET[1]	OFFSET[0]
0	0	0	0	0	0	0	0
RW	RW	RW	RW	RW	RW	RW	RW
OFFSET[7:0] GPIO2 Offset Calibration							

**8.6.1.75 Register: GPIO3\_OFF**

GPIO3_OFF Register Address: 0x49							
B7	B6	B5	B4	B3	B2	B1	B0
OFFSET[7]	OFFSET[6]	OFFSET[5]	OFFSET[4]	OFFSET[3]	OFFSET[2]	OFFSET[1]	OFFSET[0]
0	0	0	0	0	0	0	0
RW	RW	RW	RW	RW	RW	RW	RW
OFFSET[7:0] GPIO3 Offset Calibration							

### 8.6.1.76 Register: GPIO4\_OFF

GPIO4_OFF Register Address: 0x4A							
B7	B6	B5	B4	B3	B2	B1	B0
OFFSET[7]	OFFSET[6]	OFFSET[5]	OFFSET[4]	OFFSET[3]	OFFSET[2]	OFFSET[1]	OFFSET[0]
0	0	0	0	0	0	0	0
RW	RW	RW	RW	RW	RW	RW	RW
OFFSET[7:0] GPIO4 Offset Calibration							

### 8.6.1.77 Register: GPIO5\_OFF

GPIO5_OFF Register Address: 0x4B							
B7	B6	B5	B4	B3	B2	B1	B0
OFFSET[7]	OFFSET[6]	OFFSET[5]	OFFSET[4]	OFFSET[3]	OFFSET[2]	OFFSET[1]	OFFSET[0]
0	0	0	0	0	0	0	0
RW	RW	RW	RW	RW	RW	RW	RW
OFFSET[7:0] GPIO5 Offset Calibration							

### 8.6.1.78 Register: GPIO6\_OFF

GPIO6_OFF Register Address: 0x4C							
B7	B6	B5	B4	B3	B2	B1	B0
OFFSET[7]	OFFSET[6]	OFFSET[5]	OFFSET[4]	OFFSET[3]	OFFSET[2]	OFFSET[1]	OFFSET[0]
0	0	0	0	0	0	0	0
RW	RW	RW	RW	RW	RW	RW	RW
OFFSET[7:0] GPIO6 Offset Calibration							

### 8.6.1.79 Register: GPAUXCELL\_GAIN

GPAUXCELL_GAIN Register Address: 0x4D							
B7	B6	B5	B4	B3	B2	B1	B0
GAIN[7]	GAIN[6]	GAIN[5]	GAIN[4]	GAIN[3]	GAIN[2]	GAIN[1]	GAIN[0]
0	0	0	0	0	0	0	0
RW	RW	RW	RW	RW	RW	RW	RW
GAIN[7:0] GP ADC, Input1 gain calibration fro AUXCELL (Selcected cell from OVUV LS)							

### 8.6.1.80 Register: GPAUXCELL\_OFF

GPAUXCELL_OFF Register Address: 0x4E							
B7	B6	B5	B4	B3	B2	B1	B0
OFFSET[7]	OFFSET[6]	OFFSET[5]	OFFSET[4]	OFFSET[3]	OFFSET[2]	OFFSET[1]	OFFSET[0]
0	0	0	0	0	0	0	0
RW	RW	RW	RW	RW	RW	RW	RW
OFFSET[7:0] GP ADC, Input1 offset calibration for AUXCELL (Selected cell from from OVUV LS)							

### 8.6.1.81 Register: GPAUX\_GAIN

GPAUX_GAIN Register Address: 0x4F							
B7	B6	B5	B4	B3	B2	B1	B0
GAIN[7]	GAIN[6]	GAIN[5]	GAIN[4]	GAIN[3]	GAIN[2]	GAIN[1]	GAIN[0]
0	0	0	0	0	0	0	0
RW	RW	RW	RW	RW	RW	RW	RW
GAIN[7:0] GP ADC, Gain calibration for all channels except AUXCELL and GPIO1-GPIO6 channels. Example BAT, REF1, TSREF and so on.							

**8.6.1.82 Register: GPAUX\_OFF**

GPAUX_OFF Register Address: 0x50							
B7	B6	B5	B4	B3	B2	B1	B0
OFFSET[7]	OFFSET[6]	OFFSET[5]	OFFSET[4]	OFFSET[3]	OFFSET[2]	OFFSET[1]	OFFSET[0]
0	0	0	0	0	0	0	0
RW	RW	RW	RW	RW	RW	RW	RW

OFFSET[7:0] GP ADC, Offset calibration for all channels except AUXCELL and GPIO1-GPIO6 channels. Example BAT, REF1, TSREF and so on.

**8.6.1.83 Register: VC1COEFF1**

VC1COEFF1 Register Address: 0x51							
B7	B6	B5	B4	B3	B2	B1	B0
TC0A[7]	TC0A[6]	TC0A[5]	TC0A[4]	TC0A[3]	TC0A[2]	TC0A[1]	TC0A[0]
0	0	0	0	0	0	0	0
R	R	R	R	R	R	R	R

TC0A[7:0] ADC Gain TC0 Correction Coefficient (bits7-0)

**8.6.1.84 Register: VC1COEFF2**

VC1COEFF2 Register Address: 0x52							
B7	B6	B5	B4	B3	B2	B1	B0
TC1A	TC0A[6]	TC0A[5]	TC0A[4]	TC0A[3]	TC0A[2]	TC0A[1]	TC0A[0]
0	0	0	0	0	0	0	0
R	R	R	R	R	R	R	R

TC1A ADC Gain TC1 Correction Coefficient (bit 0)  
 TC0A[6:0] ADC Gain TC0 Correction Coefficient (bits14-8)

**8.6.1.85 Register: VC1COEFF3**

VC1COEFF3 Register Address: 0x53							
B7	B6	B5	B4	B3	B2	B1	B0
TC1A[7]	TC1A[6]	TC1A[5]	TC1A[4]	TC1A[3]	TC1A[2]	TC1A[1]	TC1A[0]
0	0	0	0	0	0	0	0
R	R	R	R	R	R	R	R

TC1A[7:0] ADC Gain TC1 Correction Coefficient (bits 8-1)

**8.6.1.86 Register: VC1COEFF4**

VC1COEFF4 Register Address: 0x54							
B7	B6	B5	B4	B3	B2	B1	B0
TC2A[2]	TC2A[1]	TC2A[0]	TC1A[4]	TC1A[3]	TC1A[2]	TC1A[1]	TC1A[0]
0	0	0	0	0	0	0	0
R	R	R	R	R	R	R	R

TC2A[2:0] ADC Gain TC2 Correction Coefficient (bits 2-0)  
 TC1A[4:0] ADC Gain TC1 Correction Coefficient (bits 13-9)

**8.6.1.87 Register: VC1COEFF5**

VC1COEFF5 Register Address: 0x55							
B7	B6	B5	B4	B3	B2	B1	B0
TC2A[7]	TC2A[6]	TC2A[5]	TC2A[4]	TC2A[3]	TC2A[2]	TC2A[1]	TC2A[0]
0	0	0	0	0	0	0	0
R	R	R	R	R	R	R	R

TC2A[7:0] ADC Gain TC2 Correction Coefficient (bits 10-3)

**8.6.1.88 Register: VC1COEFF6**

VC1COEFF6 Register Address: 0x56							
B7	B6	B5	B4	B3	B2	B1	B0
TC3A[4]	TC3A[3]	TC3A[2]	TC3A[1]	TC3A[0]	TC2A[2]	TC2A[1]	TC2A[0]
0	0	0	0	0	0	0	0
R	R	R	R	R	R	R	R
TC3A[4:0]		ADC Gain TC3 Correction Coefficient (bits 4-0)					
TC2A[2:0]		ADC Gain TC2 Correction Coefficient (bits 13-11)					

**8.6.1.89 Register: VC1COEFF7**

VC1COEFF7 Register Address: 0x57							
B7	B6	B5	B4	B3	B2	B1	B0
SPARE	TC3A[6]	TC3A[5]	TC3A[4]	TC3A[3]	TC3A[2]	TC3A[1]	TC3A[0]
0	0	0	0	0	0	0	0
R	R	R	R	R	R	R	R
SPARE		Spare					
TC3A[6:0]		ADC Gain TC3 Correction Coefficient (bits 11-5)					

**8.6.1.90 Register: VC1COEFF8**

VC1COEFF8 Register Address: 0x58							
B7	B6	B5	B4	B3	B2	B1	B0
TC4A[7]	TC4A[6]	TC4A[5]	TC4A[4]	TC4A[3]	TC4A[2]	TC4A[1]	TC4A[0]
0	0	0	0	0	0	0	0
R	R	R	R	R	R	R	R
TC4A[7:0]		ADC Gain TC4 Correction Coefficient (bits 7-0)					

**8.6.1.91 Register: VC1COEFF9**

VC1COEFF9 Register Address: 0x59							
B7	B6	B5	B4	B3	B2	B1	B0
TC0B[3]	TC0B[2]	TC0B[1]	TC0B[0]	TC4A[3]	TC4A[2]	TC4A[1]	TC4A[0]
0	0	0	0	0	0	0	0
R	R	R	R	R	R	R	R
TC0B[3:0]		ADC Offset TC0 Correction Coefficient (bits 3-0)					
TC4A[3:0]		ADC Gain TC4 Correction Coefficient (bits 11-8)					

**8.6.1.92 Register: VC1COEFF10**

VC1COEFF10 Register Address: 0x5A							
B7	B6	B5	B4	B3	B2	B1	B0
TC0B[7]	TC0B[6]	TC0B[5]	TC0B[4]	TC0B[3]	TC0B[2]	TC0B[1]	TC0B[0]
0	0	0	0	0	0	0	0
R	R	R	R	R	R	R	R
TC0B[7:0]		ADC Offset TC0 Correction Coefficient (bits 11-4)					

**8.6.1.93 Register: VC1COEFF11**

VC1COEFF11 Register Address: 0x5B							
B7	B6	B5	B4	B3	B2	B1	B0
TC1B[5]	TC1B[4]	TC1B[3]	TC1B[2]	TC1B[1]	TC1B[0]	TC0B[1]	TC0B[0]
0	0	0	0	0	0	0	0
R	R	R	R	R	R	R	R
TC1B[5:0]		ADC Offset TC1 Correction Coefficient (bits 5-0)					
TC0B[1:0]		ADC Offset TC0 Correction Coefficient (bits 13-12)					



**8.6.1.94 Register: VC1COEFF12**

VC1COEFF12 Register Address: 0x5C							
B7	B6	B5	B4	B3	B2	B1	B0
TC2B[1]	TC2B[0]	TC1B[5]	TC1B[4]	TC1B[3]	TC1B[2]	TC1B[1]	TC1B[0]
0	0	0	0	0	0	0	0
R	R	R	R	R	R	R	R
TC2B[1:0]		ADC Offset TC2 Correction Coefficient (bits 1-0)					
TC1B[5:0]		ADC Offset TC1 Correction Coefficient (bits 11-6)					

**8.6.1.95 Register: VC1COEFF13**

VC1COEFF13 Register Address: 0x5D							
B7	B6	B5	B4	B3	B2	B1	B0
TC2B[7]	TC2B[6]	TC2B[5]	TC2B[4]	TC2B[3]	TC2B[2]	TC2B[1]	TC2B[0]
0	0	0	0	0	0	0	0
R	R	R	R	R	R	R	R
TC2B[7:0]		ADC Offset TC2 Correction Coefficient (bits 9-2)					

**8.6.1.96 Register: VC1COEFF14**

VC1COEFF14 Register Address: 0x5E							
B7	B6	B5	B4	B3	B2	B1	B0
SPARE[5]	SPARE[4]	SPARE[3]	SPARE[2]	SPARE[1]	SPARE[0]	TC2B[1]	TC2B[0]
0	0	0	0	0	0	0	0
R	R	R	R	R	R	R	R
SPARE[5:0]		Spare					
TC2B[1:0]		ADC Offset TC2 Correction Coefficient (bits 11-10)					

**8.6.1.97 Register: VC2COEFF1**

VC2COEFF1 Register Address: 0x5F							
B7	B6	B5	B4	B3	B2	B1	B0
TC0A[7]	TC0A[6]	TC0A[5]	TC0A[4]	TC0A[3]	TC0A[2]	TC0A[1]	TC0A[0]
0	0	0	0	0	0	0	0
R	R	R	R	R	R	R	R
TC0A[7:0]		ADC Gain TC0 Correction Coefficient (bits7-0)					

**8.6.1.98 Register: VC2COEFF2**

VC2COEFF2 Register Address: 0x60							
B7	B6	B5	B4	B3	B2	B1	B0
TC1A	TC0A[6]	TC0A[5]	TC0A[4]	TC0A[3]	TC0A[2]	TC0A[1]	TC0A[0]
0	0	0	0	0	0	0	0
R	R	R	R	R	R	R	R
TC1A		ADC Gain TC1 Correction Coefficient (bit 0)					
TC0A[6:0]		ADC Gain TC0 Correction Coefficient (bits14-8)					

**8.6.1.99 Register: VC2COEFF3**

VC2COEFF3 Register Address: 0x61							
B7	B6	B5	B4	B3	B2	B1	B0
TC1A[7]	TC1A[6]	TC1A[5]	TC1A[4]	TC1A[3]	TC1A[2]	TC1A[1]	TC1A[0]
0	0	0	0	0	0	0	0
R	R	R	R	R	R	R	R
TC1A[7:0]		ADC Gain TC1 Correction Coefficient (bits 8-1)					

**8.6.1.100 Register: VC2COEFF4**

VC2COEFF4 Register Address: 0x62							
B7	B6	B5	B4	B3	B2	B1	B0
TC2A[2]	TC2A[1]	TC2A[0]	TC1A[4]	TC1A[3]	TC1A[2]	TC1A[1]	TC1A[0]
0	0	0	0	0	0	0	0
R	R	R	R	R	R	R	R
TC2A[2:0]		ADC Gain TC2 Correction Coefficient (bits 2-0)					
TC1A[4:0]			ADC Gain TC1 Correction Coefficient (bits 13-9)				

**8.6.1.101 Register: VC2COEFF5**

VC2COEFF5 Register Address: 0x63							
B7	B6	B5	B4	B3	B2	B1	B0
TC2A[7]	TC2A[6]	TC2A[5]	TC2A[4]	TC2A[3]	TC2A[2]	TC2A[1]	TC2A[0]
0	0	0	0	0	0	0	0
R	R	R	R	R	R	R	R
TC2A[7:0] ADC Gain TC2 Correction Coefficient (bits 10-3)							

**8.6.1.102 Register: VC2COEFF6**

VC2COEFF6 Register Address: 0x64							
B7	B6	B5	B4	B3	B2	B1	B0
TC3A[4]	TC3A[3]	TC3A[2]	TC3A[1]	TC3A[0]	TC2A[2]	TC2A[1]	TC2A[0]
0	0	0	0	0	0	0	0
R	R	R	R	R	R	R	R
TC3A[4:0]			ADC Gain TC3 Correction Coefficient (bits 4-0)				
TC2A[2:0]		ADC Gain TC2 Correction Coefficient (bits 13-11)					

**8.6.1.103 Register: VC2COEFF7**

VC2COEFF7 Register Address: 0x65							
B7	B6	B5	B4	B3	B2	B1	B0
SPARE	TC3A[6]	TC3A[5]	TC3A[4]	TC3A[3]	TC3A[2]	TC3A[1]	TC3A[0]
0	0	0	0	0	0	0	0
R	R	R	R	R	R	R	R
SPARE		Spare					
TC3A[6:0] ADC Gain TC3 Correction Coefficient (bits 11-5)							

**8.6.1.104 Register: VC2COEFF8**

VC2COEFF8 Register Address: 0x66							
B7	B6	B5	B4	B3	B2	B1	B0
TC4A[7]	TC4A[6]	TC4A[5]	TC4A[4]	TC4A[3]	TC4A[2]	TC4A[1]	TC4A[0]
0	0	0	0	0	0	0	0
R	R	R	R	R	R	R	R
TC4A[7:0] ADC Gain TC4 Correction Coefficient (bits 7-0)							

**8.6.1.105 Register: VC2COEFF9**

VC2COEFF9 Register Address: 0x67							
B7	B6	B5	B4	B3	B2	B1	B0
TC0B[3]	TC0B[2]	TC0B[1]	TC0B[0]	TC4A[3]	TC4A[2]	TC4A[1]	TC4A[0]
0	0	0	0	0	0	0	0
R	R	R	R	R	R	R	R
TC0B[3:0]			ADC Offset TC0 Correction Coefficient (bits 3-0)				
TC4A[3:0]				ADC Gain TC4 Correction Coefficient (bits 11-8)			

**8.6.1.106 Register: VC2COEFF10**

VC2COEFF10 Register Address: 0x68							
B7	B6	B5	B4	B3	B2	B1	B0
TC0B[7]	TC0B[6]	TC0B[5]	TC0B[4]	TC0B[3]	TC0B[2]	TC0B[1]	TC0B[0]
0	0	0	0	0	0	0	0
R	R	R	R	R	R	R	R
TC0B[7:0] ADC Offset TC0 Correction Coefficient (bits 11-4)							

**8.6.1.107 Register: VC2COEFF11**

VC2COEFF11 Register Address: 0x69							
B7	B6	B5	B4	B3	B2	B1	B0
TC1B[5]	TC1B[4]	TC1B[3]	TC1B[2]	TC1B[1]	TC1B[0]	TC0B[1]	TC0B[0]
0	0	0	0	0	0	0	0
R	R	R	R	R	R	R	R
TC1B[5:0] ADC Offset TC1 Correction Coefficient (bits 5-0)							
TC0B[1:0] ADC Offset TC0 Correction Coefficient (bits 13-12)							

**8.6.1.108 Register: VC2COEFF12**

VC2COEFF12 Register Address: 0x6A							
B7	B6	B5	B4	B3	B2	B1	B0
TC2B[1]	TC2B[0]	TC1B[5]	TC1B[4]	TC1B[3]	TC1B[2]	TC1B[1]	TC1B[0]
0	0	0	0	0	0	0	0
R	R	R	R	R	R	R	R
TC2B[1:0] ADC Offset TC2 Correction Coefficient (bits 1-0)							
TC1B[5:0] ADC Offset TC1 Correction Coefficient (bits 11-6)							

**8.6.1.109 Register: VC2COEFF13**

VC2COEFF13 Register Address: 0x6B							
B7	B6	B5	B4	B3	B2	B1	B0
TC2B[7]	TC2B[6]	TC2B[5]	TC2B[4]	TC2B[3]	TC2B[2]	TC2B[1]	TC2B[0]
0	0	0	0	0	0	0	0
R	R	R	R	R	R	R	R
TC2B[7:0] ADC Offset TC2 Correction Coefficient (bits 9-2)							

**8.6.1.110 Register: VC2COEFF14**

VC2COEFF14 Register Address: 0x6C							
B7	B6	B5	B4	B3	B2	B1	B0
SPARE[5]	SPARE[4]	SPARE[3]	SPARE[2]	SPARE[1]	SPARE[0]	TC2B[1]	TC2B[0]
0	0	0	0	0	0	0	0
R	R	R	R	R	R	R	R
SPARE[5:0] Spare							
TC2B[1:0] ADC Offset TC2 Correction Coefficient (bits 11-10)							

**8.6.1.111 Register: VC3COEFF1**

VC3COEFF1 Register Address: 0x6D							
B7	B6	B5	B4	B3	B2	B1	B0
TC0A[7]	TC0A[6]	TC0A[5]	TC0A[4]	TC0A[3]	TC0A[2]	TC0A[1]	TC0A[0]
0	0	0	0	0	0	0	0
R	R	R	R	R	R	R	R
TC0A[7:0] ADC Gain TC0 Correction Coefficient (bits 7-0)							

**8.6.1.112 Register: VC3COEFF2**

VC3COEFF2 Register Address: 0x6E							
B7	B6	B5	B4	B3	B2	B1	B0
TC1A	TC0A[6]	TC0A[5]	TC0A[4]	TC0A[3]	TC0A[2]	TC0A[1]	TC0A[0]
0	0	0	0	0	0	0	0
R	R	R	R	R	R	R	R
TC1A		ADC Gain TC1 Correction Coefficient (bit 0)					
TC0A[6:0]		ADC Gain TC0 Correction Coefficient (bits14-8)					

**8.6.1.113 Register: VC3COEFF3**

VC3COEFF3 Register Address: 0x6F							
B7	B6	B5	B4	B3	B2	B1	B0
TC1A[7]	TC1A[6]	TC1A[5]	TC1A[4]	TC1A[3]	TC1A[2]	TC1A[1]	TC1A[0]
0	0	0	0	0	0	0	0
R	R	R	R	R	R	R	R
TC1A[7:0]		ADC Gain TC1 Correction Coefficient (bits 8-1)					

**8.6.1.114 Register: VC3COEFF4**

VC3COEFF4 Register Address: 0x70							
B7	B6	B5	B4	B3	B2	B1	B0
TC2A[2]	TC2A[1]	TC2A[0]	TC1A[4]	TC1A[3]	TC1A[2]	TC1A[1]	TC1A[0]
0	0	0	0	0	0	0	0
R	R	R	R	R	R	R	R
TC2A[2:0]		ADC Gain TC2 Correction Coefficient (bits 2-0)					
TC1A[4:0]		ADC Gain TC1 Correction Coefficient (bits 13-9)					

**8.6.1.115 Register: VC3COEFF5**

VC3COEFF5 Register Address: 0x71							
B7	B6	B5	B4	B3	B2	B1	B0
TC2A[7]	TC2A[6]	TC2A[5]	TC2A[4]	TC2A[3]	TC2A[2]	TC2A[1]	TC2A[0]
0	0	0	0	0	0	0	0
R	R	R	R	R	R	R	R
TC2A[7:0]		ADC Gain TC2 Correction Coefficient (bits 10-3)					

**8.6.1.116 Register: VC3COEFF6**

VC3COEFF6 Register Address: 0x72							
B7	B6	B5	B4	B3	B2	B1	B0
TC3A[4]	TC3A[3]	TC3A[2]	TC3A[1]	TC3A[0]	TC2A[2]	TC2A[1]	TC2A[0]
0	0	0	0	0	0	0	0
R	R	R	R	R	R	R	R
TC3A[4:0]		ADC Gain TC3 Correction Coefficient (bits 4-0)					
TC2A[2:0]		ADC Gain TC2 Correction Coefficient (bits 13-11)					

**8.6.1.117 Register: VC3COEFF7**

VC3COEFF7 Register Address: 0x73							
B7	B6	B5	B4	B3	B2	B1	B0
SPARE	TC3A[6]	TC3A[5]	TC3A[4]	TC3A[3]	TC3A[2]	TC3A[1]	TC3A[0]
0	0	0	0	0	0	0	0
R	R	R	R	R	R	R	R
SPARE		Spare					
TC3A[6:0]		ADC Gain TC3 Correction Coefficient (bits 11-5)					

**8.6.1.118 Register: VC3COEFF8**

VC3COEFF8 Register Address: 0x74							
B7	B6	B5	B4	B3	B2	B1	B0
TC4A[7]	TC4A[6]	TC4A[5]	TC4A[4]	TC4A[3]	TC4A[2]	TC4A[1]	TC4A[0]
0	0	0	0	0	0	0	0
R	R	R	R	R	R	R	R
TC4A[7:0] ADC Gain TC4 Correction Coefficient (bits 7-0)							

**8.6.1.119 Register: VC3COEFF9**

VC3COEFF9 Register Address: 0x75							
B7	B6	B5	B4	B3	B2	B1	B0
TC0B[3]	TC0B[2]	TC0B[1]	TC0B[0]	TC4A[3]	TC4A[2]	TC4A[1]	TC4A[0]
0	0	0	0	0	0	0	0
R	R	R	R	R	R	R	R
TC0B[3:0] ADC Offset TC0 Correction Coefficient (bits 3-0)							
TC4A[3:0] ADC Gain TC4 Correction Coefficient (bits 11-8)							

**8.6.1.120 Register: VC3COEFF10**

VC3COEFF10 Register Address: 0x76							
B7	B6	B5	B4	B3	B2	B1	B0
TC0B[7]	TC0B[6]	TC0B[5]	TC0B[4]	TC0B[3]	TC0B[2]	TC0B[1]	TC0B[0]
0	0	0	0	0	0	0	0
R	R	R	R	R	R	R	R
TC0B[7:0] ADC Offset TC0 Correction Coefficient (bits 11-4)							

**8.6.1.121 Register: VC3COEFF11**

VC3COEFF11 Register Address: 0x77							
B7	B6	B5	B4	B3	B2	B1	B0
TC1B[5]	TC1B[4]	TC1B[3]	TC1B[2]	TC1B[1]	TC1B[0]	TC0B[1]	TC0B[0]
0	0	0	0	0	0	0	0
R	R	R	R	R	R	R	R
TC1B[5:0] ADC Offset TC1 Correction Coefficient (bits 5-0)							
TC0B[1:0] ADC Offset TC0 Correction Coefficient (bits 13-12)							

**8.6.1.122 Register: VC3COEFF12**

VC3COEFF12 Register Address: 0x78							
B7	B6	B5	B4	B3	B2	B1	B0
TC2B[1]	TC2B[0]	TC1B[5]	TC1B[4]	TC1B[3]	TC1B[2]	TC1B[1]	TC1B[0]
0	0	0	0	0	0	0	0
R	R	R	R	R	R	R	R
TC2B[1:0] ADC Offset TC2 Correction Coefficient (bits 1-0)							
TC1B[5:0] ADC Offset TC1 Correction Coefficient (bits 11-6)							

**8.6.1.123 Register: VC3COEFF13**

VC3COEFF13 Register Address: 0x79							
B7	B6	B5	B4	B3	B2	B1	B0
TC2B[7]	TC2B[6]	TC2B[5]	TC2B[4]	TC2B[3]	TC2B[2]	TC2B[1]	TC2B[0]
0	0	0	0	0	0	0	0
R	R	R	R	R	R	R	R
TC2B[7:0] ADC Offset TC2 Correction Coefficient (bits 9-2)							

**8.6.1.124 Register: VC3COEFF14**

VC3COEFF14 Register Address: 0x7A							
B7	B6	B5	B4	B3	B2	B1	B0
SPARE[5]	SPARE[4]	SPARE[3]	SPARE[2]	SPARE[1]	SPARE[0]	TC2B[1]	TC2B[0]
0	0	0	0	0	0	0	0
R	R	R	R	R	R	R	R
SPARE[5:0]		Spare					
TC2B[1:0]		ADC Offset TC2 Correction Coefficient (bits 11-10)					

**8.6.1.125 Register: VC4COEFF1**

VC4COEFF1 Register Address: 0x7B							
B7	B6	B5	B4	B3	B2	B1	B0
TC0A[7]	TC0A[6]	TC0A[5]	TC0A[4]	TC0A[3]	TC0A[2]	TC0A[1]	TC0A[0]
0	0	0	0	0	0	0	0
R	R	R	R	R	R	R	R
TC0A[7:0]		ADC Gain TC0 Correction Coefficient (bits7-0)					

**8.6.1.126 Register: VC4COEFF2**

VC4COEFF2 Register Address: 0x7C							
B7	B6	B5	B4	B3	B2	B1	B0
TC1A	TC0A[6]	TC0A[5]	TC0A[4]	TC0A[3]	TC0A[2]	TC0A[1]	TC0A[0]
0	0	0	0	0	0	0	0
R	R	R	R	R	R	R	R
TC1A	ADC Gain TC1 Correction Coefficient (bit 0)						
TC0A[6:0]		ADC Gain TC0 Correction Coefficient (bits14-8)					

**8.6.1.127 Register: VC4COEFF3**

VC4COEFF3 Register Address: 0x7D							
B7	B6	B5	B4	B3	B2	B1	B0
TC1A[7]	TC1A[6]	TC1A[5]	TC1A[4]	TC1A[3]	TC1A[2]	TC1A[1]	TC1A[0]
0	0	0	0	0	0	0	0
R	R	R	R	R	R	R	R
TC1A[7:0]		ADC Gain TC1 Correction Coefficient (bits 8-1)					

**8.6.1.128 Register: VC4COEFF4**

VC4COEFF4 Register Address: 0x7E							
B7	B6	B5	B4	B3	B2	B1	B0
TC2A[2]	TC2A[1]	TC2A[0]	TC1A[4]	TC1A[3]	TC1A[2]	TC1A[1]	TC1A[0]
0	0	0	0	0	0	0	0
R	R	R	R	R	R	R	R
TC2A[2:0]		ADC Gain TC2 Correction Coefficient (bits 2-0)					
TC1A[4:0]		ADC Gain TC1 Correction Coefficient (bits 13-9)					

**8.6.1.129 Register: VC4COEFF5**

VC4COEFF5 Register Address: 0x7F							
B7	B6	B5	B4	B3	B2	B1	B0
TC2A[7]	TC2A[6]	TC2A[5]	TC2A[4]	TC2A[3]	TC2A[2]	TC2A[1]	TC2A[0]
0	0	0	0	0	0	0	0
R	R	R	R	R	R	R	R
TC2A[7:0]		ADC Gain TC2 Correction Coefficient (bits 10-3)					

**8.6.1.130 Register: VC4COEFF6**

VC4COEFF6 Register Address: 0x80							
B7	B6	B5	B4	B3	B2	B1	B0
TC3A[4]	TC3A[3]	TC3A[2]	TC3A[1]	TC3A[0]	TC2A[2]	TC2A[1]	TC2A[0]
0	0	0	0	0	0	0	0
R	R	R	R	R	R	R	R
TC3A[4:0]		ADC Gain TC3 Correction Coefficient (bits 4-0)					
TC2A[2:0]		ADC Gain TC2 Correction Coefficient (bits 13-11)					

**8.6.1.131 Register: VC4COEFF7**

VC4COEFF7 Register Address: 0x81							
B7	B6	B5	B4	B3	B2	B1	B0
SPARE	TC3A[6]	TC3A[5]	TC3A[4]	TC3A[3]	TC3A[2]	TC3A[1]	TC3A[0]
0	0	0	0	0	0	0	0
R	R	R	R	R	R	R	R
SPARE		Spare					
TC3A[6:0]		ADC Gain TC3 Correction Coefficient (bits 11-5)					

**8.6.1.132 Register: VC4COEFF8**

VC4COEFF8 Register Address: 0x82							
B7	B6	B5	B4	B3	B2	B1	B0
TC4A[7]	TC4A[6]	TC4A[5]	TC4A[4]	TC4A[3]	TC4A[2]	TC4A[1]	TC4A[0]
0	0	0	0	0	0	0	0
R	R	R	R	R	R	R	R
TC4A[7:0]		ADC Gain TC4 Correction Coefficient (bits 7-0)					

**8.6.1.133 Register: VC4COEFF9**

VC4COEFF9 Register Address: 0x83							
B7	B6	B5	B4	B3	B2	B1	B0
TC0B[3]	TC0B[2]	TC0B[1]	TC0B[0]	TC4A[3]	TC4A[2]	TC4A[1]	TC4A[0]
0	0	0	0	0	0	0	0
R	R	R	R	R	R	R	R
TC0B[3:0]		ADC Offset TC0 Correction Coefficient (bits 3-0)					
TC4A[3:0]		ADC Gain TC4 Correction Coefficient (bits 11-8)					

**8.6.1.134 Register: VC4COEFF10**

VC4COEFF10 Register Address: 0x84							
B7	B6	B5	B4	B3	B2	B1	B0
TC0B[7]	TC0B[6]	TC0B[5]	TC0B[4]	TC0B[3]	TC0B[2]	TC0B[1]	TC0B[0]
0	0	0	0	0	0	0	0
R	R	R	R	R	R	R	R
TC0B[7:0]		ADC Offset TC0 Correction Coefficient (bits 11-4)					

**8.6.1.135 Register: VC4COEFF11**

VC4COEFF11 Register Address: 0x85							
B7	B6	B5	B4	B3	B2	B1	B0
TC1B[5]	TC1B[4]	TC1B[3]	TC1B[2]	TC1B[1]	TC1B[0]	TC0B[1]	TC0B[0]
0	0	0	0	0	0	0	0
R	R	R	R	R	R	R	R
TC1B[5:0]		ADC Offset TC1 Correction Coefficient (bits 5-0)					
TC0B[1:0]		ADC Offset TC0 Correction Coefficient (bits 13-12)					

**8.6.1.136 Register: VC4COEFF12**

VC4COEFF12 Register Address: 0x86							
B7	B6	B5	B4	B3	B2	B1	B0
TC2B[1]	TC2B[0]	TC1B[5]	TC1B[4]	TC1B[3]	TC1B[2]	TC1B[1]	TC1B[0]
0	0	0	0	0	0	0	0
R	R	R	R	R	R	R	R
TC2B[1:0]		ADC Offset TC2 Correction Coefficient (bits 1-0)					
TC1B[5:0]		ADC Offset TC1 Correction Coefficient (bits 11-6)					

**8.6.1.137 Register: VC4COEFF13**

VC4COEFF13 Register Address: 0x87							
B7	B6	B5	B4	B3	B2	B1	B0
TC2B[7]	TC2B[6]	TC2B[5]	TC2B[4]	TC2B[3]	TC2B[2]	TC2B[1]	TC2B[0]
0	0	0	0	0	0	0	0
R	R	R	R	R	R	R	R
TC2B[7:0]		ADC Offset TC2 Correction Coefficient (bits 9-2)					

**8.6.1.138 Register: VC4COEFF14**

VC4COEFF14 Register Address: 0x88							
B7	B6	B5	B4	B3	B2	B1	B0
SPARE[5]	SPARE[4]	SPARE[3]	SPARE[2]	SPARE[1]	SPARE[0]	TC2B[1]	TC2B[0]
0	0	0	0	0	0	0	0
R	R	R	R	R	R	R	R
SPARE[5:0]		Spare					
TC2B[1:0]		ADC Offset TC2 Correction Coefficient (bits 11-10)					

**8.6.1.139 Register: VC5COEFF1**

VC5COEFF1 Register Address: 0x89							
B7	B6	B5	B4	B3	B2	B1	B0
TC0A[7]	TC0A[6]	TC0A[5]	TC0A[4]	TC0A[3]	TC0A[2]	TC0A[1]	TC0A[0]
0	0	0	0	0	0	0	0
R	R	R	R	R	R	R	R
TC0A[7:0]		ADC Gain TC0 Correction Coefficient (bits 7-0)					

**8.6.1.140 Register: VC5COEFF2**

VC5COEFF2 Register Address: 0x8A							
B7	B6	B5	B4	B3	B2	B1	B0
TC1A	TC0A[6]	TC0A[5]	TC0A[4]	TC0A[3]	TC0A[2]	TC0A[1]	TC0A[0]
0	0	0	0	0	0	0	0
R	R	R	R	R	R	R	R
TC1A	ADC Gain TC1 Correction Coefficient (bit 0)						
TC0A[6:0]		ADC Gain TC0 Correction Coefficient (bits 14-8)					

**8.6.1.141 Register: VC5COEFF3**

VC5COEFF3 Register Address: 0x8B							
B7	B6	B5	B4	B3	B2	B1	B0
TC1A[7]	TC1A[6]	TC1A[5]	TC1A[4]	TC1A[3]	TC1A[2]	TC1A[1]	TC1A[0]
0	0	0	0	0	0	0	0
R	R	R	R	R	R	R	R
TC1A[7:0]		ADC Gain TC1 Correction Coefficient (bits 8-1)					



**8.6.1.142 Register: VC5COEFF4**

VC5COEFF4 Register Address: 0x8C							
B7	B6	B5	B4	B3	B2	B1	B0
TC2A[2]	TC2A[1]	TC2A[0]	TC1A[4]	TC1A[3]	TC1A[2]	TC1A[1]	TC1A[0]
0	0	0	0	0	0	0	0
R	R	R	R	R	R	R	R
TC2A[2:0]		ADC Gain TC2 Correction Coefficient (bits 2-0)					
TC1A[4:0]			ADC Gain TC1 Correction Coefficient (bits 13-9)				

**8.6.1.143 Register: VC5COEFF5**

VC5COEFF5 Register Address: 0x8D							
B7	B6	B5	B4	B3	B2	B1	B0
TC2A[7]	TC2A[6]	TC2A[5]	TC2A[4]	TC2A[3]	TC2A[2]	TC2A[1]	TC2A[0]
0	0	0	0	0	0	0	0
R	R	R	R	R	R	R	R
TC2A[7:0]		ADC Gain TC2 Correction Coefficient (bits 10-3)					

**8.6.1.144 Register: VC5COEFF6**

VC5COEFF6 Register Address: 0x8E							
B7	B6	B5	B4	B3	B2	B1	B0
TC3A[4]	TC3A[3]	TC3A[2]	TC3A[1]	TC3A[0]	TC2A[2]	TC2A[1]	TC2A[0]
0	0	0	0	0	0	0	0
R	R	R	R	R	R	R	R
TC3A[4:0]		ADC Gain TC3 Correction Coefficient (bits 4-0)					
TC2A[2:0]		ADC Gain TC2 Correction Coefficient (bits 13-11)					

**8.6.1.145 Register: VC5COEFF7**

VC5COEFF7 Register Address: 0x8F							
B7	B6	B5	B4	B3	B2	B1	B0
SPARE	TC3A[6]	TC3A[5]	TC3A[4]	TC3A[3]	TC3A[2]	TC3A[1]	TC3A[0]
0	0	0	0	0	0	0	0
R	R	R	R	R	R	R	R
SPARE		Spare					
TC3A[6:0]		ADC Gain TC3 Correction Coefficient (bits 11-5)					

**8.6.1.146 Register: VC5COEFF8**

VC5COEFF8 Register Address: 0x90							
B7	B6	B5	B4	B3	B2	B1	B0
TC4A[7]	TC4A[6]	TC4A[5]	TC4A[4]	TC4A[3]	TC4A[2]	TC4A[1]	TC4A[0]
0	0	0	0	0	0	0	0
R	R	R	R	R	R	R	R
TC4A[7:0]		ADC Gain TC4 Correction Coefficient (bits 7-0)					

**8.6.1.147 Register: VC5COEFF9**

VC5COEFF9 Register Address: 0x91							
B7	B6	B5	B4	B3	B2	B1	B0
TC0B[3]	TC0B[2]	TC0B[1]	TC0B[0]	TC4A[3]	TC4A[2]	TC4A[1]	TC4A[0]
0	0	0	0	0	0	0	0
R	R	R	R	R	R	R	R
TC0B[3:0]		ADC Offset TC0 Correction Coefficient (bits 3-0)					
TC4A[3:0]		ADC Gain TC4 Correction Coefficient (bits 11-8)					

**8.6.1.148 Register: VC5COEFF10**

VC5COEFF10 Register Address: 0x92							
B7	B6	B5	B4	B3	B2	B1	B0
TC0B[7]	TC0B[6]	TC0B[5]	TC0B[4]	TC0B[3]	TC0B[2]	TC0B[1]	TC0B[0]
0	0	0	0	0	0	0	0
R	R	R	R	R	R	R	R
TC0B[7:0] ADC Offset TC0 Correction Coefficient (bits 11-4)							

**8.6.1.149 Register: VC5COEFF11**

VC5COEFF11 Register Address: 0x93							
B7	B6	B5	B4	B3	B2	B1	B0
TC1B[5]	TC1B[4]	TC1B[3]	TC1B[2]	TC1B[1]	TC1B[0]	TC0B[1]	TC0B[0]
0	0	0	0	0	0	0	0
R	R	R	R	R	R	R	R
TC1B[5:0] ADC Offset TC1 Correction Coefficient (bits 5-0)							
TC0B[1:0] ADC Offset TC0 Correction Coefficient (bits 13-12)							

**8.6.1.150 Register: VC5COEFF12**

VC5COEFF12 Register Address: 0x94							
B7	B6	B5	B4	B3	B2	B1	B0
TC2B[1]	TC2B[0]	TC1B[5]	TC1B[4]	TC1B[3]	TC1B[2]	TC1B[1]	TC1B[0]
0	0	0	0	0	0	0	0
R	R	R	R	R	R	R	R
TC2B[1:0] ADC Offset TC2 Correction Coefficient (bits 1-0)							
TC1B[5:0] ADC Offset TC1 Correction Coefficient (bits 11-6)							

**8.6.1.151 Register: VC5COEFF13**

VC5COEFF13 Register Address: 0x95							
B7	B6	B5	B4	B3	B2	B1	B0
TC2B[7]	TC2B[6]	TC2B[5]	TC2B[4]	TC2B[3]	TC2B[2]	TC2B[1]	TC2B[0]
0	0	0	0	0	0	0	0
R	R	R	R	R	R	R	R
TC2B[7:0] ADC Offset TC2 Correction Coefficient (bits 9-2)							

**8.6.1.152 Register: VC5COEFF14**

VC5COEFF14 Register Address: 0x96							
B7	B6	B5	B4	B3	B2	B1	B0
SPARE[5]	SPARE[4]	SPARE[3]	SPARE[2]	SPARE[1]	SPARE[0]	TC2B[1]	TC2B[0]
0	0	0	0	0	0	0	0
R	R	R	R	R	R	R	R
SPARE[5:0] Spare							
TC2B[1:0] ADC Offset TC2 Correction Coefficient (bits 11-10)							

**8.6.1.153 Register: VC6COEFF1**

VC6COEFF1 Register Address: 0x97							
B7	B6	B5	B4	B3	B2	B1	B0
TC0A[7]	TC0A[6]	TC0A[5]	TC0A[4]	TC0A[3]	TC0A[2]	TC0A[1]	TC0A[0]
0	0	0	0	0	0	0	0
R	R	R	R	R	R	R	R
TC0A[7:0] ADC Gain TC0 Correction Coefficient (bits 7-0)							

**8.6.1.154 Register: VC6COEFF2**

VC6COEFF2 Register Address: 0x98							
B7	B6	B5	B4	B3	B2	B1	B0
TC1A	TC0A[6]	TC0A[5]	TC0A[4]	TC0A[3]	TC0A[2]	TC0A[1]	TC0A[0]
0	0	0	0	0	0	0	0
R	R	R	R	R	R	R	R
TC1A		ADC Gain TC1 Correction Coefficient (bit 0)					
TC0A[6:0]		ADC Gain TC0 Correction Coefficient (bits14-8)					

**8.6.1.155 Register: VC6COEFF3**

VC6COEFF3 Register Address: 0x99							
B7	B6	B5	B4	B3	B2	B1	B0
TC1A[7]	TC1A[6]	TC1A[5]	TC1A[4]	TC1A[3]	TC1A[2]	TC1A[1]	TC1A[0]
0	0	0	0	0	0	0	0
R	R	R	R	R	R	R	R
TC1A[7:0]		ADC Gain TC1 Correction Coefficient (bits 8-1)					

**8.6.1.156 Register: VC6COEFF4**

VC6COEFF4 Register Address: 0x9A							
B7	B6	B5	B4	B3	B2	B1	B0
TC2A[2]	TC2A[1]	TC2A[0]	TC1A[4]	TC1A[3]	TC1A[2]	TC1A[1]	TC1A[0]
0	0	0	0	0	0	0	0
R	R	R	R	R	R	R	R
TC2A[2:0]		ADC Gain TC2 Correction Coefficient (bits 2-0)					
TC1A[4:0]		ADC Gain TC1 Correction Coefficient (bits 13-9)					

**8.6.1.157 Register: VC6COEFF5**

VC6COEFF5 Register Address: 0x9B							
B7	B6	B5	B4	B3	B2	B1	B0
TC2A[7]	TC2A[6]	TC2A[5]	TC2A[4]	TC2A[3]	TC2A[2]	TC2A[1]	TC2A[0]
0	0	0	0	0	0	0	0
R	R	R	R	R	R	R	R
TC2A[7:0]		ADC Gain TC2 Correction Coefficient (bits 10-3)					

**8.6.1.158 Register: VC6COEFF6**

VC6COEFF6 Register Address: 0x9C							
B7	B6	B5	B4	B3	B2	B1	B0
TC3A[4]	TC3A[3]	TC3A[2]	TC3A[1]	TC3A[0]	TC2A[2]	TC2A[1]	TC2A[0]
0	0	0	0	0	0	0	0
R	R	R	R	R	R	R	R
TC3A[4:0]		ADC Gain TC3 Correction Coefficient (bits 4-0)					
TC2A[2:0]		ADC Gain TC2 Correction Coefficient (bits 13-11)					

**8.6.1.159 Register: VC6COEFF7**

VC6COEFF7 Register Address: 0x9D							
B7	B6	B5	B4	B3	B2	B1	B0
SPARE	TC3A[6]	TC3A[5]	TC3A[4]	TC3A[3]	TC3A[2]	TC3A[1]	TC3A[0]
0	0	0	0	0	0	0	0
R	R	R	R	R	R	R	R
SPARE		Spare					
TC3A[6:0]		ADC Gain TC3 Correction Coefficient (bits 11-5)					

**8.6.1.160 Register: VC6COEFF8**

VC6COEFF8 Register Address: 0x9E							
B7	B6	B5	B4	B3	B2	B1	B0
TC4A[7]	TC4A[6]	TC4A[5]	TC4A[4]	TC4A[3]	TC4A[2]	TC4A[1]	TC4A[0]
0	0	0	0	0	0	0	0
R	R	R	R	R	R	R	R
TC4A[7:0] ADC Gain TC4 Correction Coefficient (bits 7-0)							

**8.6.1.161 Register: VC6COEFF9**

VC6COEFF9 Register Address: 0x9F							
B7	B6	B5	B4	B3	B2	B1	B0
TC0B[3]	TC0B[2]	TC0B[1]	TC0B[0]	TC4A[3]	TC4A[2]	TC4A[1]	TC4A[0]
0	0	0	0	0	0	0	0
R	R	R	R	R	R	R	R
TC0B[3:0] ADC Offset TC0 Correction Coefficient (bits 3-0)							
TC4A[3:0] ADC Gain TC4 Correction Coefficient (bits 11-8)							

**8.6.1.162 Register: VC6COEFF10**

VC6COEFF10 Register Address: 0xA0							
B7	B6	B5	B4	B3	B2	B1	B0
TC0B[7]	TC0B[6]	TC0B[5]	TC0B[4]	TC0B[3]	TC0B[2]	TC0B[1]	TC0B[0]
0	0	0	0	0	0	0	0
R	R	R	R	R	R	R	R
TC0B[7:0] ADC Offset TC0 Correction Coefficient (bits 11-4)							

**8.6.1.163 Register: VC6COEFF11**

VC6COEFF11 Register Address: 0xA1							
B7	B6	B5	B4	B3	B2	B1	B0
TC1B[5]	TC1B[4]	TC1B[3]	TC1B[2]	TC1B[1]	TC1B[0]	TC0B[1]	TC0B[0]
0	0	0	0	0	0	0	0
R	R	R	R	R	R	R	R
TC1B[5:0] ADC Offset TC1 Correction Coefficient (bits 5-0)							
TC0B[1:0] ADC Offset TC0 Correction Coefficient (bits 13-12)							

**8.6.1.164 Register: VC6COEFF12**

VC6COEFF12 Register Address: 0xA2							
B7	B6	B5	B4	B3	B2	B1	B0
TC2B[1]	TC2B[0]	TC1B[5]	TC1B[4]	TC1B[3]	TC1B[2]	TC1B[1]	TC1B[0]
0	0	0	0	0	0	0	0
R	R	R	R	R	R	R	R
TC2B[1:0] ADC Offset TC2 Correction Coefficient (bits 1-0)							
TC1B[5:0] ADC Offset TC1 Correction Coefficient (bits 11-6)							

**8.6.1.165 Register: VC6COEFF13**

VC6COEFF13 Register Address: 0xA3							
B7	B6	B5	B4	B3	B2	B1	B0
TC2B[7]	TC2B[6]	TC2B[5]	TC2B[4]	TC2B[3]	TC2B[2]	TC2B[1]	TC2B[0]
0	0	0	0	0	0	0	0
R	R	R	R	R	R	R	R
TC2B[7:0] ADC Offset TC2 Correction Coefficient (bits 9-2)							

**8.6.1.166 Register: VC6COEFF14**

VC6COEFF14 Register Address: 0xA4							
B7	B6	B5	B4	B3	B2	B1	B0
SPARE[5]	SPARE[4]	SPARE[3]	SPARE[2]	SPARE[1]	SPARE[0]	TC2B[1]	TC2B[0]
0	0	0	0	0	0	0	0
R	R	R	R	R	R	R	R
SPARE[5:0]		Spare					
TC2B[1:0]		ADC Offset TC2 Correction Coefficient (bits 11-10)					

**8.6.1.167 Register: VAUXCOEFF1**

VAUXCOEFF1 Register Address: 0xA5							
B7	B6	B5	B4	B3	B2	B1	B0
TC0A[7]	TC0A[6]	TC0A[5]	TC0A[4]	TC0A[3]	TC0A[2]	TC0A[1]	TC0A[0]
0	0	0	0	0	0	0	0
R	R	R	R	R	R	R	R
TC0A[7:0]		ADC Gain TC0 Correction Coefficient (bits7-0)					

**8.6.1.168 Register: VAUXCOEFF2**

VAUXCOEFF2 Register Address: 0xA6							
B7	B6	B5	B4	B3	B2	B1	B0
TC1A	TC0A[6]	TC0A[5]	TC0A[4]	TC0A[3]	TC0A[2]	TC0A[1]	TC0A[0]
0	0	0	0	0	0	0	0
R	R	R	R	R	R	R	R
TC1A	ADC Gain TC1 Correction Coefficient (bit 0)						
TC0A[6:0]		ADC Gain TC0 Correction Coefficient (bits14-8)					

**8.6.1.169 Register: VAUXCOEFF3**

VAUXCOEFF3 Register Address: 0xA7							
B7	B6	B5	B4	B3	B2	B1	B0
TC1A[7]	TC1A[6]	TC1A[5]	TC1A[4]	TC1A[3]	TC1A[2]	TC1A[1]	TC1A[0]
0	0	0	0	0	0	0	0
R	R	R	R	R	R	R	R
TC1A[7:0]		ADC Gain TC1 Correction Coefficient (bits 8-1)					

**8.6.1.170 Register: VAUXCOEFF4**

VAUXCOEFF4 Register Address: 0xA8							
B7	B6	B5	B4	B3	B2	B1	B0
TC2A[2]	TC2A[1]	TC2A[0]	TC1A[4]	TC1A[3]	TC1A[2]	TC1A[1]	TC1A[0]
0	0	0	0	0	0	0	0
R	R	R	R	R	R	R	R
TC2A[2:0]		ADC Gain TC2 Correction Coefficient (bits 2-0)					
TC1A[4:0]		ADC Gain TC1 Correction Coefficient (bits 13-9)					

**8.6.1.171 Register: VAUXCOEFF5**

VAUXCOEFF5 Register Address: 0xA9							
B7	B6	B5	B4	B3	B2	B1	B0
TC2A[7]	TC2A[6]	TC2A[5]	TC2A[4]	TC2A[3]	TC2A[2]	TC2A[1]	TC2A[0]
0	0	0	0	0	0	0	0
R	R	R	R	R	R	R	R
TC2A[7:0]		ADC Gain TC2 Correction Coefficient (bits 10-3)					

**8.6.1.172 Register: VAUXCOEFF6**

VAUXCOEFF6 Register Address: 0xAA							
B7	B6	B5	B4	B3	B2	B1	B0
TC3A[4]	TC3A[3]	TC3A[2]	TC3A[1]	TC3A[0]	TC2A[2]	TC2A[1]	TC2A[0]
0	0	0	0	0	0	0	0
R	R	R	R	R	R	R	R
TC3A[4:0]		ADC Gain TC3 Correction Coefficient (bits 4-0)					
TC2A[2:0]		ADC Gain TC2 Correction Coefficient (bits 13-11)					

**8.6.1.173 Register: VAUXCOEFF7**

VAUXCOEFF7 Register Address: 0xAB							
B7	B6	B5	B4	B3	B2	B1	B0
SPARE	TC3A[6]	TC3A[5]	TC3A[4]	TC3A[3]	TC3A[2]	TC3A[1]	TC3A[0]
0	0	0	0	0	0	0	0
R	R	R	R	R	R	R	R
SPARE		Spare					
TC3A[6:0]		ADC Gain TC3 Correction Coefficient (bits 11-5)					

**8.6.1.174 Register: VAUXCOEFF8**

VAUXCOEFF8 Register Address: 0xAC							
B7	B6	B5	B4	B3	B2	B1	B0
TC4A[7]	TC4A[6]	TC4A[5]	TC4A[4]	TC4A[3]	TC4A[2]	TC4A[1]	TC4A[0]
0	0	0	0	0	0	0	0
R	R	R	R	R	R	R	R
TC4A[7:0]		ADC Gain TC4 Correction Coefficient (bits 7-0)					

**8.6.1.175 Register: VAUXCOEFF9**

VAUXCOEFF9 Register Address: 0xAD							
B7	B6	B5	B4	B3	B2	B1	B0
TC0B[3]	TC0B[2]	TC0B[1]	TC0B[0]	TC4A[3]	TC4A[2]	TC4A[1]	TC4A[0]
0	0	0	0	0	0	0	0
R	R	R	R	R	R	R	R
TC0B[3:0]		ADC Offset TC0 Correction Coefficient (bits 3-0)					
TC4A[3:0]		ADC Gain TC4 Correction Coefficient (bits 11-8)					

**8.6.1.176 Register: VAUXCOEFF10**

VAUXCOEFF10 Register Address: 0xAE							
B7	B6	B5	B4	B3	B2	B1	B0
TC0B[7]	TC0B[6]	TC0B[5]	TC0B[4]	TC0B[3]	TC0B[2]	TC0B[1]	TC0B[0]
0	0	0	0	0	0	0	0
R	R	R	R	R	R	R	R
TC0B[7:0]		ADC Offset TC0 Correction Coefficient (bits 11-4)					

**8.6.1.177 Register: VAUXCOEFF11**

VAUXCOEFF11 Register Address: 0xAF							
B7	B6	B5	B4	B3	B2	B1	B0
TC1B[5]	TC1B[4]	TC1B[3]	TC1B[2]	TC1B[1]	TC1B[0]	TC0B[1]	TC0B[0]
0	0	0	0	0	0	0	0
R	R	R	R	R	R	R	R
TC1B[5:0]		ADC Offset TC1 Correction Coefficient (bits 5-0)					
TC0B[1:0]		ADC Offset TC0 Correction Coefficient (bits 13-12)					

**8.6.1.178 Register: VAUXCOEFF12**

VAUXCOEFF12 Register Address: 0xB0							
B7	B6	B5	B4	B3	B2	B1	B0
TC2B[1]	TC2B[0]	TC1B[5]	TC1B[4]	TC1B[3]	TC1B[2]	TC1B[1]	TC1B[0]
0	0	0	0	0	0	0	0
R	R	R	R	R	R	R	R
TC2B[1:0]		ADC Offset TC2 Correction Coefficient (bits 1-0)					
TC1B[5:0]		ADC Offset TC1 Correction Coefficient (bits 11-6)					

**8.6.1.179 Register: VAUXCOEFF13**

VAUXCOEFF13 Register Address: 0xB1							
B7	B6	B5	B4	B3	B2	B1	B0
TC2B[7]	TC2B[6]	TC2B[5]	TC2B[4]	TC2B[3]	TC2B[2]	TC2B[1]	TC2B[0]
0	0	0	0	0	0	0	0
R	R	R	R	R	R	R	R
TC2B[7:0]		ADC Offset TC2 Correction Coefficient (bits 9-2)					

**8.6.1.180 Register: VAUXCOEFF14**

VAUXCOEFF14 Register Address: 0xB2							
B7	B6	B5	B4	B3	B2	B1	B0
SPARE[5]	SPARE[4]	SPARE[3]	SPARE[2]	SPARE[1]	SPARE[0]	TC2B[1]	TC2B[0]
0	0	0	0	0	0	0	0
R	R	R	R	R	R	R	R
SPARE[5:0]		Spare					
TC2B[1:0]		ADC Offset TC2 Correction Coefficient (bits 11-10)					

**8.6.1.181 Register: VAUXCELLCOEFF1**

VAUXCELLCOEFF1 Register Address: 0xB3							
B7	B6	B5	B4	B3	B2	B1	B0
TC0A[7]	TC0A[6]	TC0A[5]	TC0A[4]	TC0A[3]	TC0A[2]	TC0A[1]	TC0A[0]
0	0	0	0	0	0	0	0
R	R	R	R	R	R	R	R
TC0A[7:0]		ADC Gain TC0 Correction Coefficient (bits7-0)					

**8.6.1.182 Register: VAUXCELLCOEFF2**

VAUXCELLCOEFF2 Register Address: 0xB4							
B7	B6	B5	B4	B3	B2	B1	B0
TC1A	TC0A[6]	TC0A[5]	TC0A[4]	TC0A[3]	TC0A[2]	TC0A[1]	TC0A[0]
0	0	0	0	0	0	0	0
R	R	R	R	R	R	R	R
TC1A	ADC Gain TC1 Correction Coefficient (bit 0)						
TC0A[6:0]		ADC Gain TC0 Correction Coefficient (bits14-8)					

**8.6.1.183 Register: VAUXCELLCOEFF3**

VAUXCELLCOEFF3 Register Address: 0xB5							
B7	B6	B5	B4	B3	B2	B1	B0
TC1A[7]	TC1A[6]	TC1A[5]	TC1A[4]	TC1A[3]	TC1A[2]	TC1A[1]	TC1A[0]
0	0	0	0	0	0	0	0
R	R	R	R	R	R	R	R
TC1A[7:0]		ADC Gain TC1 Correction Coefficient (bits 8-1)					

**8.6.1.184 Register: VAUXCELLCOEFF4**

VAUXCELLCOEFF4 Register Address: 0xB6							
B7	B6	B5	B4	B3	B2	B1	B0
TC2A[2]	TC2A[1]	TC2A[0]	TC1A[4]	TC1A[3]	TC1A[2]	TC1A[1]	TC1A[0]
0	0	0	0	0	0	0	0
R	R	R	R	R	R	R	R
TC2A[2:0]		ADC Gain TC2 Correction Coefficient (bits 2-0)					
TC1A[4:0]			ADC Gain TC1 Correction Coefficient (bits 13-9)				

**8.6.1.185 Register: VAUXCELLCOEFF5**

VAUXCELLCOEFF5 Register Address: 0xB7							
B7	B6	B5	B4	B3	B2	B1	B0
TC2A[7]	TC2A[6]	TC2A[5]	TC2A[4]	TC2A[3]	TC2A[2]	TC2A[1]	TC2A[0]
0	0	0	0	0	0	0	0
R	R	R	R	R	R	R	R
TC2A[7:0] ADC Gain TC2 Correction Coefficient (bits 10-3)							

**8.6.1.186 Register: VAUXCELLCOEFF6**

VAUXCELLCOEFF6 Register Address: 0xB8							
B7	B6	B5	B4	B3	B2	B1	B0
TC3A[4]	TC3A[3]	TC3A[2]	TC3A[1]	TC3A[0]	TC2A[2]	TC2A[1]	TC2A[0]
0	0	0	0	0	0	0	0
R	R	R	R	R	R	R	R
TC3A[4:0]			ADC Gain TC3 Correction Coefficient (bits 4-0)				
TC2A[2:0]		ADC Gain TC2 Correction Coefficient (bits 13-11)					

**8.6.1.187 Register: VAUXCELLCOEFF7**

VAUXCELLCOEFF7 Register Address: 0xB9							
B7	B6	B5	B4	B3	B2	B1	B0
SPARE	TC3A[6]	TC3A[5]	TC3A[4]	TC3A[3]	TC3A[2]	TC3A[1]	TC3A[0]
0	0	0	0	0	0	0	0
R	R	R	R	R	R	R	R
SPARE		Spare					
TC3A[6:0] ADC Gain TC3 Correction Coefficient (bits 11-5)							

**8.6.1.188 Register: VAUXCELLCOEFF8**

VAUXCELLCOEFF8 Register Address: 0xBA							
B7	B6	B5	B4	B3	B2	B1	B0
TC4A[7]	TC4A[6]	TC4A[5]	TC4A[4]	TC4A[3]	TC4A[2]	TC4A[1]	TC4A[0]
0	0	0	0	0	0	0	0
R	R	R	R	R	R	R	R
TC4A[7:0] ADC Gain TC4 Correction Coefficient (bits 7-0)							

**8.6.1.189 Register: VAUXCELLCOEFF9**

VAUXCELLCOEFF9 Register Address: 0xBB							
B7	B6	B5	B4	B3	B2	B1	B0
TC0B[3]	TC0B[2]	TC0B[1]	TC0B[0]	TC4A[3]	TC4A[2]	TC4A[1]	TC4A[0]
0	0	0	0	0	0	0	0
R	R	R	R	R	R	R	R
TC0B[3:0]			ADC Offset TC0 Correction Coefficient (bits 3-0)				
TC4A[3:0]				ADC Gain TC4 Correction Coefficient (bits 11-8)			



**8.6.1.190 Register: VAUXCELLCOEFF10**

VAUXCELLCOEFF10 Register Address: 0xBC							
B7	B6	B5	B4	B3	B2	B1	B0
TC0B[7]	TC0B[6]	TC0B[5]	TC0B[4]	TC0B[3]	TC0B[2]	TC0B[1]	TC0B[0]
0	0	0	0	0	0	0	0
R	R	R	R	R	R	R	R
TC0B[7:0] ADC Offset TC0 Correction Coefficient (bits 11-4)							

**8.6.1.191 Register: VAUXCELLCOEFF11**

VAUXCELLCOEFF11 Register Address: 0xBD							
B7	B6	B5	B4	B3	B2	B1	B0
TC1B[5]	TC1B[4]	TC1B[3]	TC1B[2]	TC1B[1]	TC1B[0]	TC0B[1]	TC0B[0]
0	0	0	0	0	0	0	0
R	R	R	R	R	R	R	R
TC1B[5:0] ADC Offset TC1 Correction Coefficient (bits 5-0)							
TC0B[1:0] ADC Offset TC0 Correction Coefficient (bits 13-12)							

**8.6.1.192 Register: VAUXCELLCOEFF12**

VAUXCELLCOEFF12 Register Address: 0xBE							
B7	B6	B5	B4	B3	B2	B1	B0
TC2B[1]	TC2B[0]	TC1B[5]	TC1B[4]	TC1B[3]	TC1B[2]	TC1B[1]	TC1B[0]
0	0	0	0	0	0	0	0
R	R	R	R	R	R	R	R
TC2B[1:0] ADC Offset TC2 Correction Coefficient (bits 1-0)							
TC1B[5:0] ADC Offset TC1 Correction Coefficient (bits 11-6)							

**8.6.1.193 Register: VAUXCELLCOEFF13**

VAUXCELLCOEFF13 Register Address: 0xBF							
B7	B6	B5	B4	B3	B2	B1	B0
TC2B[7]	TC2B[6]	TC2B[5]	TC2B[4]	TC2B[3]	TC2B[2]	TC2B[1]	TC2B[0]
0	0	0	0	0	0	0	0
R	R	R	R	R	R	R	R
TC2B[7:0] ADC Offset TC2 Correction Coefficient (bits 9-2)							

**8.6.1.194 Register: VAUXCELLCOEFF14**

VAUXCELLCOEFF14 Register Address: 0xC0							
B7	B6	B5	B4	B3	B2	B1	B0
SPARE[5]	SPARE[4]	SPARE[3]	SPARE[2]	SPARE[1]	SPARE[0]	TC2B[1]	TC2B[0]
0	0	0	0	0	0	0	0
R	R	R	R	R	R	R	R
SPARE[5:0] Spare							
TC2B[1:0] ADC Offset TC2 Correction Coefficient (bits 11-10)							

**8.6.1.195 Register: SPARE\_6**

SPARE_6 Register Address: 0xC1							
B7	B6	B5	B4	B3	B2	B1	B0
SPARE[7]	SPARE[6]	SPARE[5]	SPARE[4]	SPARE[3]	SPARE[2]	SPARE[1]	SPARE[0]
0	0	0	0	0	0	0	0
RW	RW	RW	RW	RW	RW	RW	RW
SPARE[7:0] This register is used to store the VPTAT_OFFSET in factory.							

**8.6.1.196 Register: CUST\_MISC1**

CUST_MISC1 Register Address: 0xC2							
B7	B6	B5	B4	B3	B2	B1	B0
SPARE[7]	SPARE[6]	SPARE[5]	SPARE[4]	SPARE[3]	SPARE[2]	SPARE[1]	SPARE[0]
0	0	0	0	0	0	0	0
RW	RW	RW	RW	RW	RW	RW	RW
SPARE[7:0] Customer Miscellaneous ; out of factory samples use this for corrected ADC channel corrected error value: b7,6,5,4 - AUXCELL HI; b4,3,2,1 - AUXCELL LO							

**8.6.1.197 Register: CUST\_MISC2**

CUST_MISC2 Register Address: 0xC3							
B7	B6	B5	B4	B3	B2	B1	B0
SPARE[7]	SPARE[6]	SPARE[5]	SPARE[4]	SPARE[3]	SPARE[2]	SPARE[1]	SPARE[0]
0	0	0	0	0	0	0	0
RW	RW	RW	RW	RW	RW	RW	RW
SPARE[7:0] Customer Miscellaneous ; out of factory samples use this for corrected ADC channel error value: b7,6,5,4 - AUX HI; b4,3,2,1 - AUX LO							

**8.6.1.198 Register: CUST\_MISC3**

CUST_MISC3 Register Address: 0xC4							
B7	B6	B5	B4	B3	B2	B1	B0
SPARE[7]	SPARE[6]	SPARE[5]	SPARE[4]	SPARE[3]	SPARE[2]	SPARE[1]	SPARE[0]
0	0	0	0	0	0	0	0
RW	RW	RW	RW	RW	RW	RW	RW
SPARE[7:0] Customer Miscellaneous ; out of factory samples use this for corrected ADC channel error sign b7,6- VC2 HI/LO; b5,4- VC1 HI/LO; b3,2 - AUX HI/LO, B1,0-AUXCELL HI/LO							

**8.6.1.199 Register: CUST\_MISC4**

CUST_MISC4 Register Address: 0xC5							
B7	B6	B5	B4	B3	B2	B1	B0
SPARE[7]	SPARE[6]	SPARE[5]	SPARE[4]	SPARE[3]	SPARE[2]	SPARE[1]	SPARE[0]
0	0	0	0	0	0	0	0
RW	RW	RW	RW	RW	RW	RW	RW
SPARE[7:0] Customer Miscellaneous ; out of factory samples use this for corrected ADC channel error sign b7,6- VC6 HI/LO; b5,4- VC5 HI/LO; b3,2 - VC4 HI/LO, B1,0-VC3 HI/LO							

**8.6.1.200 Register: CUST\_CRCH**

CUST_CRCH Register Address: 0xC6							
B7	B6	B5	B4	B3	B2	B1	B0
CRCH[7]	CRCH[6]	CRCH[5]	CRCH[4]	CRCH[3]	CRCH[2]	CRCH[1]	CRCH[0]
1	0	1	1	1	1	1	0
RW	RW	RW	RW	RW	RW	RW	RW
CRCH[7:0] Customer programmed CRC high byte							

**8.6.1.201 Register: CUST\_CRCL**

CUST_CRCL Register Address: 0xC7							
B7	B6	B5	B4	B3	B2	B1	B0
CRCL[7]	CRCL[6]	CRCL[5]	CRCL[4]	CRCL[3]	CRCL[2]	CRCL[1]	CRCL[0]
1	0	1	0	0	0	1	1
RW	RW	RW	RW	RW	RW	RW	RW
CRCL[7:0] Customer programmed CRC low byte							

**8.6.1.202 Register: OTP\_PROG\_UNLOCK1A**

OTP_PROG_UNLOCK1A Register Address: 0x100							
B7	B6	B5	B4	B3	B2	B1	B0
UNLOCK[7]	UNLOCK[6]	UNLOCK[5]	UNLOCK[4]	UNLOCK[3]	UNLOCK[2]	UNLOCK[1]	UNLOCK[0]
0	0	0	0	0	0	0	0
RW	RW	RW	RW	RW	RW	RW	RW
UNLOCK[7:0] First of two confirmation commands required before OTP programming. Must be written in sequence from OTP_PROG_UNLOCK1A to OTP_PROG_UNLOCK1D (OTP_PROG_UNLOCK1A > OTP_PROG_UNLOCK1B > OTP_PROG_UNLOCK1C > OTP_PROG_UNLOCK1D). Always returns 0x00 when read. Once the correct sequence is entered and the OTP is unlocked, the next write clears the lock condition. The write following the final unlock command must be to OTP_PROG_CTRL[PROG_GO] to program the OTP.							

**8.6.1.203 Register: OTP\_PROG\_UNLOCK1B**

OTP_PROG_UNLOCK1B Register Address: 0x101							
B7	B6	B5	B4	B3	B2	B1	B0
UNLOCK[7]	UNLOCK[6]	UNLOCK[5]	UNLOCK[4]	UNLOCK[3]	UNLOCK[2]	UNLOCK[1]	UNLOCK[0]
0	0	0	0	0	0	0	0
RW	RW	RW	RW	RW	RW	RW	RW
UNLOCK[7:0] First of two confirmation commands required before OTP programming. Must be written in sequence from OTP_PROG_UNLOCK1A to OTP_PROG_UNLOCK1D (OTP_PROG_UNLOCK1A > OTP_PROG_UNLOCK1B > OTP_PROG_UNLOCK1C > OTP_PROG_UNLOCK1D). Always returns 0x00 when read. Once the correct sequence is entered and the OTP is unlocked, the next write clears the lock condition. The write following the final unlock command must be to OTP_PROG_CTRL[PROG_GO] to program the OTP.							

**8.6.1.204 Register: OTP\_PROG\_UNLOCK1C**

OTP_PROG_UNLOCK1C Register Address: 0x102							
B7	B6	B5	B4	B3	B2	B1	B0
UNLOCK[7]	UNLOCK[6]	UNLOCK[5]	UNLOCK[4]	UNLOCK[3]	UNLOCK[2]	UNLOCK[1]	UNLOCK[0]
0	0	0	0	0	0	0	0
RW	RW	RW	RW	RW	RW	RW	RW
UNLOCK[7:0] First of two confirmation commands required before OTP programming. Must be written in sequence from OTP_PROG_UNLOCK1A to OTP_PROG_UNLOCK1D (OTP_PROG_UNLOCK1A > OTP_PROG_UNLOCK1B > OTP_PROG_UNLOCK1C > OTP_PROG_UNLOCK1D). Always returns 0x00 when read. Once the correct sequence is entered and the OTP is unlocked, the next write clears the lock condition. The write following the final unlock command must be to OTP_PROG_CTRL[PROG_GO] to program the OTP.							

**8.6.1.205 Register: OTP\_PROG\_UNLOCK1D**

OTP_PROG_UNLOCK1D Register Address: 0x103							
B7	B6	B5	B4	B3	B2	B1	B0
UNLOCK[7]	UNLOCK[6]	UNLOCK[5]	UNLOCK[4]	UNLOCK[3]	UNLOCK[2]	UNLOCK[1]	UNLOCK[0]
0	0	0	0	0	0	0	0
RW	RW	RW	RW	RW	RW	RW	RW
UNLOCK[7:0] First of two confirmation commands required before OTP programming. Must be written in sequence from OTP_PROG_UNLOCK1A to OTP_PROG_UNLOCK1D (OTP_PROG_UNLOCK1A > OTP_PROG_UNLOCK1B > OTP_PROG_UNLOCK1C > OTP_PROG_UNLOCK1D). Always returns 0x00 when read. Once the correct sequence is entered and the OTP is unlocked, the next write clears the lock condition. The write following the final unlock command must be to OTP_PROG_CTRL[PROG_GO] to program the OTP.							

**8.6.1.206 Register: DEVADD\_USR**

DEVADD_USR Register Address: 0x104							
B7	B6	B5	B4	B3	B2	B1	B0
RSVD[1]	RSVD[0]	ADD[5]	ADD[4]	ADD[3]	ADD[2]	ADD[1]	ADD[0]
0	0	0	0	0	0	0	0
R	R	RW	RW	RW	RW	RW	RW
RSVD[1:0] Reserved							
ADD[5:0] Programmable Device Stack Address. These bits are only written when CONTROL1[ADD_WRITE_EN] = 1. Otherwise, these bits are "Read Only". See the "Device Addressing" section for more details. DEV_ADD_STAT reflects the current device address							

**8.6.1.207 Register: CONTROL1**

CONTROL1 Register Address: 0x105							
B7	B6	B5	B4	B3	B2	B1	B0
DIR_SEL	SEND_SHUTDO WN	SEND_WAKE	SEND_SLPTOAC T	GOTO_SHUTDO WN	GOTO_SLEEP	SOFT_RESET	ADD_WRITE_EN
0	0	0	0	0	0	0	0
RW	RW	RW	RW	RW	RW	RW	RW
DIR_SEL	Selects daisy chain communication Command Frame direction 0: Transmit (Command Frame) direction North (COML to COMH of the same device) 1: Transmit (Command Frame) direction South (COMH to COML of the same device)						
SEND_SHUTDO WN	Sends SHUTDOWN tone to the next device up the stack to shut down the device and send it to SHUTDOWN mode. This device is unaffected. 0: Ready 1: Send SHUTDOWN tone Always reads '0'						
SEND_WAKE	Sends WAKE tone up the stack to wake and reset stack devices. This command resets the devices to OTP defaults. 0: Ready 1: Send WAKE tone Always reads '0'						
SEND_SLPTOAC T	Sends SLEEPtoACTIVE tone up the stack to wake stack devices. This command does NOT reset devices. 0: Ready 1: Send SLEEPtoACTIVE tone Always reads '0'						
GOTO_SHUTDO WN	Transitions device to SHUTDOWN mode 0: Ready 1: SHUTDOWN mode Always reads '0'						
GOTO_SLEEP	Transitions device to SLEEP mode 0: Ready 1: SLEEP mode Always reads '0'						
SOFT_RESET	Resets device to OTP default values. 0: Ready 1: Reset device Always reads '0'						
ADD_WRITE_EN	Enable addressing mode. CONFIG[GPIO_ADDR_SEL] = 0: The daisy chain interface does not transmit while ADD_WRITE_EN = 1 (when not using GPIO addressing). See the Auto Addressing section for more details. CONFIG[GPIO_ADDR_SEL] = 1: The DEV_ADD_STAT[ADDR] bits are updated according to the enabled GPIO states. See the GPIO Addressing section for more details. 0: Ready 1: Enables addressing mode. Cleared once a valid command frame is received.						

**8.6.1.208 Register: CONTROL2**

CONTROL2 Register Address: 0x106							
B7	B6	B5	B4	B3	B2	B1	B0
VPTAT_EN	DAISY_CHAIN_CTRL_EN	BAL_GO	TSREF_EN	OTUT_EN	OVUV_EN	AUX_ADC_GO	CELL_ADC_GO
0	0	0	0	0	0	0	0
RW	RW	RW	RW	RW	RW	RW	RW
VPTAT_EN	Enables the VPTAT output to be available for ADC read. VPTAT_EN must be set to 1 before the ADC read is done to ensure the correct result. When not in use, it is recommended that VPTAT_EN is '0' to avoid any noise coupling on to internal nodes. 0: VPTAT output to ADC MUX disabled 1: VPTAT output to ADC MUX enabled						
DAISY_CHAIN_CTRL_EN	Selects the control for the daisy chain TX and RX functions. See the "Daisy Chain Transmitter and Receiver Functionality" section for more details. Note that after enabling COMM Rx, wait for at least 100usec before start communication. 0: COMH/COML TX/RX function is controlled by hardware if DAISY_CHAIN_STAT[HW_DRV]=1 and if DAISY_CHAIN_STAT[HW_DRV]=0 then is controlled by DAISY_CHAIN_CTRL register. 1: COMH/COML TX/RX function controlled by DAISY_CHAIN_CTRL register.						
BAL_GO	Start Cell Balancing. When written, all cell balancing configuration registers are sampled. Any changes to the configuration registers have no effect until BAL_GO bit is written. 0: Ready 1: Start cell balancing Always reads '0'						
TSREF_EN	Enables the TSREF LDO output 0: Disables 1: Enabled						
OTUT_EN	Enables the OT/UT comparators selected in the OTUT_CTRL register. Once enabled, any changes to the configuration registers have no effect until OTUT_EN bit is cleared and then set. 0: Ready 1: Enabled						
OVUV_EN	Enables the OV/UV comparators selected in the OVUV_CTRL register. Once enabled, any changes to the configuration registers have no effect until OVUV_EN bit is cleared and then set. 0: Ready 1: Enabled						
AUX_ADC_GO	Start AUX ADC conversion(s). When written, all ADC configuration registers are sampled. Any changes to the configuration registers have no effect until AUX_ADC_GO bit is written. 0: Ready 1: Start AUX ADC conversion(s) Always reads '0'						
CELL_ADC_GO	Start CELL ADC conversion(s). When written, all ADC configuration registers are sampled. Any changes to the configuration registers have no effect until CELL_ADC_GO bit is written. 0: Ready 1: Start CELL ADC conversion(s) Always reads '0'						

**8.6.1.209 Register: OTP\_PROG\_CTRL**

OTP_PROG_CTRL Register Address: 0x107							
B7	B6	B5	B4	B3	B2	B1	B0
RSVD[5]	RSVD[4]	RSVD[3]	RSVD[2]	RSVD[1]	RSVD[0]	PAGESEL	PROG_GO
0	0	0	0	0	0	0	0
R	R	R	R	R	R	RW	RW
RSVD[5:0]	reserved						
PAGESEL	Selects customer OTP page for programming 0: Page 1 1: Page 2						
PROG_GO	Enables programming for the OTP page selected by OTP_PROG_CTRL[PAGESEL]. Requires OTP_PROG_UNLOCK1_ and OTP_PROG_UNLOCK2_ registers are set to the correct codes. 0: Ready 1: Enable programming Always reads '0'						

### 8.6.1.210 Register: GPIO\_OUT

GPIO_OUT Register Address: 0x108							
B7	B6	B5	B4	B3	B2	B1	B0
RSVD[1]	RSVD[0]	GPIO6	GPIO5	GPIO4	GPIO3	GPIO2	GPIO1
0	0	0	0	0	0	0	0
R	R	RW	RW	RW	RW	RW	RW
RSVD[1:0]		Reserved					
GPIO6		Sets GPIO6 state when configured as an output. (only valid when GPIO is configured as an output) 0: Low 1: High					
GPIO5		Sets GPIO5 state when configured as an output. (only valid when GPIO is configured as an output) 0: Low 1: High					
GPIO4		Sets GPIO4 state when configured as an output. (only valid when GPIO is configured as an output) 0: Low 1: High					
GPIO3		Sets GPIO3 state when configured as an output. (only valid when GPIO is configured as an output) 0: Low 1: High					
GPIO2		Sets GPIO2 state when configured as an output. (only valid when GPIO is configured as an output) 0: Low 1: High					
GPIO1		Sets GPIO1 state when configured as an output. (only valid when GPIO is configured as an output) 0: Low 1: High					

### 8.6.1.211 Register: CELL\_ADC\_CTRL

CELL_ADC_CTRL Register Address: 0x109							
B7	B6	B5	B4	B3	B2	B1	B0
RSVD[1]	RSVD[0]	CELL6_EN	CELL5_EN	CELL4_EN	CELL3_EN	CELL2_EN	CELL1_EN
0	0	0	0	0	0	0	0
R	R	RW	RW	RW	RW	RW	RW
RSVD[1:0]		Reserved					
CELL6_EN		Enables ADC conversions for CELL6. When '1', the CELL6 level shifter is enabled. 0: Disabled 1: Enabled					
CELL5_EN		Enables ADC conversions for CELL5. When '1', the CELL5 level shifter is enabled. 0: Disabled 1: Enabled					
CELL4_EN		Enables ADC conversions for CELL4. When '1', the CELL4 level shifter is enabled. 0: Disabled 1: Enabled					
CELL3_EN		Enables ADC conversions for CELL3. When '1', the CELL3 level shifter is enabled. 0: Disabled 1: Enabled					
CELL2_EN		Enables ADC conversions for CELL2. When '1', the CELL2 level shifter is enabled. 0: Disabled 1: Enabled					
CELL1_EN		Enables ADC conversions for CELL1. When '1', the CELL1 level shifter is enabled. 0: Disabled 1: Enabled					

**8.6.1.212 Register: AUX\_ADC\_CTRL1**

AUX_ADC_CTRL1 Register Address: 0x10A							
B7	B6	B5	B4	B3	B2	B1	B0
GPIO4_EN	GPIO3_EN	GPIO2_EN	GPIO1_EN	AVDD_EN	ZERO_EN	REF2_EN	BAT_EN
0	0	0	0	0	0	0	0
RW	RW	RW	RW	RW	RW	RW	RW
GPIO4_EN	Enables conversion of GPIO4 for the AUX ADC. 0: Disabled 1: Enabled						
GPIO3_EN	Enables conversion of GPIO3 for the AUX ADC. 0: Disabled 1: Enabled						
GPIO2_EN	Enables conversion of GPIO2 for the AUX ADC. 0: Disabled 1: Enabled						
GPIO1_EN	Enables conversion of GPIO1 for the AUX ADC. 0: Disabled 1: Enabled						
AVDD_EN	Enables conversion of AVDD for the AUX ADC. 0: Disabled 1: Enabled						
ZERO_EN	Enables conversion of 0V reference for the AUX ADC. 0: Disabled 1: Enabled						
REF2_EN	Enables conversion of Bandgap 1 for the AUX ADC. 0: Disabled 1: Enabled						
BAT_EN	Enables conversion of BAT for the AUX ADC. 0: Disabled 1: Enabled						

**8.6.1.213 Register: AUX\_ADC\_CTRL2**

AUX_ADC_CTRL2 Register Address: 0x10B							
B7	B6	B5	B4	B3	B2	B1	B0
TWARN_PTAT_EN	UT_DAC_EN	OT_DAC_EN	UV_DAC_EN	OV_DAC_EN	REF3_EN	GPIO6_EN	GPIO5_EN
0	0	0	0	0	0	0	0
RW	RW	RW	RW	RW	RW	RW	RW
TWARN_PTAT_EN	Enables conversion of TWARN PTAT current for the AUX ADC. 0: Disabled 1: Enabled						
UT_DAC_EN	Enables conversion of UT reference for the AUX ADC. 0: Disabled 1: Enabled						
OT_DAC_EN	Enables conversion of OT reference for the AUX ADC. 0: Disabled 1: Enabled						
UV_DAC_EN	Enables conversion of UV reference for the AUX ADC. Do not set AUX_CELL channel by setting AUX_CELL_SEL_EN and AUX_CELL_SEL[2:0] in DIAG_CTRL2 when UV_DAC_EN is set to 1. 0: Disabled 1: Enabled						
OV_DAC_EN	Enables conversion of OV reference for the AUX ADC. Do not set AUX_CELL channel by setting AUX_CELL_SEL_EN and AUX_CELL_SEL[2:0] in DIAG_CTRL2 when OV_DAC_EN is set to 1. 0: Disabled 1: Enabled						
REF3_EN	Enables conversion of Bandgap 2 for the AUX ADC. 0: Disabled 1: Enabled						
GPIO6_EN	Enables conversion of GPIO6 for the AUX ADC. 0: Disabled 1: Enabled						
GPIO5_EN	Enables conversion of GPIO5 for the AUX ADC. 0: Disabled 1: Enabled						

**8.6.1.214 Register: AUX\_ADC\_CTRL3**

AUX_ADC_CTRL3 Register Address: 0x10C							
B7	B6	B5	B4	B3	B2	B1	B0
RSVD[3]	RSVD[2]	RSVD[1]	RSVD[0]	AVAO_REF_EN	CVDD_EN	TSREF_EN	DVDD_EN
0	0	0	0	0	0	0	0
R	R	R	R	RW	RW	RW	RW
RSVD[3:0]	Reserved						
AVAO_REF_EN	Enables conversion of AVAO_REF reference for the AUX ADC. 0: Disabled 1: Enabled						
CVDD_EN	Enables conversion of CVDD for the AUX ADC. 0: Disabled 1: Enabled						
TSREF_EN	Enables conversion of TSREF for the AUX ADC. 0: Disabled 1: Enabled						
DVDD_EN	Enables conversion of DVDD for the AUX ADC. 0: Disabled 1: Enabled						

**8.6.1.215 Register: CB\_CONFIG**

CB_CONFIG Register Address: 0x10D							
B7	B6	B5	B4	B3	B2	B1	B0
DUTY_UNIT	DUTY[3]	DUTY[2]	DUTY[1]	DUTY[0]	FLTSTOP	SEQ[1]	SEQ[0]
0	0	0	0	0	0	0	0
RW	RW	RW	RW	RW	RW	RW	RW
DUTY_UNIT	Sets time division for CB_CONFIG[DUTY] field. The selected unit need to match the unit on the CB_CELL*_CTRL[TIME_UNIT]. 0: Minutes 1: Seconds						
DUTY[3:0]	Sets time for cell balancing duty cycle function. See "Cell Balancing" section for details on operation. Programmable from 0 to 30 with a step size of 2 (seconds or minutes depending on CB_CONFIG[DUTY_UNIT])						
FLTSTOP	Controls cell balancing behavior during fault conditions. 0: Balancing continues regardless of fault condition (excluding thermal shutdown) 1: Balancing stops when any unmasked fault condition occurs						
SEQ[1:0]	Controls channel sequence during cell balancing. 00: Odds only 01: Evens only 10: Odds then Evens 11: Evens then Odds						

**8.6.1.216 Register: CB\_CELL1\_CTRL**

CB_CELL1_CTRL Register Address: 0x10E							
B7	B6	B5	B4	B3	B2	B1	B0
TIME_UNIT	TIME[6]	TIME[5]	TIME[4]	TIME[3]	TIME[2]	TIME[1]	TIME[0]
0	0	0	0	0	0	0	0
RW	RW	RW	RW	RW	RW	RW	RW
TIME_UNIT	Sets time division for CB_CELL1_CTRL[TIME] field. The selected unit need to match the unit on the CB_CONFIG[DUTY_UNIT]. 0: Minutes 1: Seconds						
TIME[6:0]	Sets time for CELL1 cell balancing. See "Cell Balancing" section for details on operation. Programmable from 0 to 127 with a step size of 1 (seconds or minutes depending on CB_CELL1_CTRL[TIME_UNIT])						



**8.6.1.217 Register: CB\_CELL2\_CTRL**

CB_CELL2_CTRL Register Address: 0x10F							
B7	B6	B5	B4	B3	B2	B1	B0
TIME_UNIT	TIME[6]	TIME[5]	TIME[4]	TIME[3]	TIME[2]	TIME[1]	TIME[0]
0	0	0	0	0	0	0	0
RW	RW	RW	RW	RW	RW	RW	RW
TIME_UNIT	Sets time division for CB_CELL2_CTRL[TIME] field. The selected unit need to match the unit on the CB_CONFIG[DUTY_UNIT]. 0: Minutes 1: Seconds						
TIME[6:0]	Sets time for CELL2 cell balancing. See "Cell Balancing" section for details on operation. Programmable from 0 to 127 with a step size of 1 (seconds or minutes depending on CB_CELL2_CTRL[TIME_UNIT])						

**8.6.1.218 Register: CB\_CELL3\_CTRL**

CB_CELL3_CTRL Register Address: 0x110							
B7	B6	B5	B4	B3	B2	B1	B0
TIME_UNIT	TIME[6]	TIME[5]	TIME[4]	TIME[3]	TIME[2]	TIME[1]	TIME[0]
0	0	0	0	0	0	0	0
RW	RW	RW	RW	RW	RW	RW	RW
TIME_UNIT	Sets time division for CB_CELL3_CTRL[TIME] field. The selected unit need to match the unit on the CB_CONFIG[DUTY_UNIT]. 0: Minutes 1: Seconds						
TIME[6:0]	Sets time for CELL3 cell balancing. See "Cell Balancing" section for details on operation. Programmable from 0 to 127 with a step size of 1 (seconds or minutes depending on CB_CELL3_CTRL[TIME_UNIT])						

**8.6.1.219 Register: CB\_CELL4\_CTRL**

CB_CELL4_CTRL Register Address: 0x111							
B7	B6	B5	B4	B3	B2	B1	B0
TIME_UNIT	TIME[6]	TIME[5]	TIME[4]	TIME[3]	TIME[2]	TIME[1]	TIME[0]
0	0	0	0	0	0	0	0
RW	RW	RW	RW	RW	RW	RW	RW
TIME_UNIT	Sets time division for CB_CELL4_CTRL[TIME] field. The selected unit need to match the unit on the CB_CONFIG[DUTY_UNIT]. 0: Minutes 1: Seconds						
TIME[6:0]	Sets time for CELL4 cell balancing. See "Cell Balancing" section for details on operation. Programmable from 0 to 127 with a step size of 1 (seconds or minutes depending on CB_CELL4_CTRL[TIME_UNIT])						

**8.6.1.220 Register: CB\_CELL5\_CTRL**

CB_CELL5_CTRL Register Address: 0x112							
B7	B6	B5	B4	B3	B2	B1	B0
TIME_UNIT	TIME[6]	TIME[5]	TIME[4]	TIME[3]	TIME[2]	TIME[1]	TIME[0]
0	0	0	0	0	0	0	0
RW	RW	RW	RW	RW	RW	RW	RW
TIME_UNIT	Sets time division for CB_CELL1_CTRL[TIME] field. The selected unit need to match the unit on the CB_CONFIG[DUTY_UNIT]. 0: Minutes 1: Seconds						
TIME[6:0]	Sets time for CELL1 cell balancing. See "Cell Balancing" section for details on operation. Programmable from 0 to 127 with a step size of 1 (seconds or minutes depending on CB_CELL1_CTRL[TIME_UNIT])						

**8.6.1.221 Register: CB\_CELL6\_CTRL**

CB_CELL6_CTRL Register Address: 0x113							
B7	B6	B5	B4	B3	B2	B1	B0
TIME_UNIT	TIME[6]	TIME[5]	TIME[4]	TIME[3]	TIME[2]	TIME[1]	TIME[0]
0	0	0	0	0	0	0	0
RW	RW	RW	RW	RW	RW	RW	RW
TIME_UNIT	Sets time division for CB_CELL6_CTRL[TIME] field. The selected unit need to match the unit on the CB_CONFIG[DUTY_UNIT]. 0: Minutes 1: Seconds						
TIME[6:0]	Sets time for CELL6 cell balancing. See "Cell Balancing" section for details on operation. Programmable from 0 to 127 with a step size of 1 (seconds or minutes depending on CB_CELL6_CTRL[TIME_UNIT])						

**8.6.1.222 Register: CB\_DONE\_THRESH**

CB_DONE_THRESH Register Address: 0x114							
B7	B6	B5	B4	B3	B2	B1	B0
RSVD	ENABLE	THRESH[5]	THRESH[4]	THRESH[3]	THRESH[2]	THRESH[1]	THRESH[0]
0	0	1	0	0	0	0	0
R	RW	RW	RW	RW	RW	RW	RW
RSVD	Reserved						
ENABLE	Controls enable for the CBDONE comparator function 0: Disable 1: Enable						
THRESH[5:0]	Cell balancing done threshold Programmable from 2.8V to 4.3V with 25mV step size. Value is capped at 4.3V. Selections 0b111100 - 0b111111 set 4.3V threshold.						

**8.6.1.223 Register: CB\_SW\_EN**

CB_SW_EN Register Address: 0x115							
B7	B6	B5	B4	B3	B2	B1	B0
SW_EN	CB_PAUSE	CELL6_EN	CELL5_EN	CELL4_EN	CELL3_EN	CELL2_EN	CELL1_EN
0	0	0	0	0	0	0	0
RW	RW	RW	RW	RW	RW	RW	RW
SW_EN	Controls the manual enable for the cell balancing switches. When enabled, the switches selected in CB_SW_EN[CELL*_EN] bits are turned on. If any consecutive switches are enabled, none of the switches are turned on. 0: Disabled 1: Enabled						
CB_PAUSE	Pauses cell balancing to allow for diagnostics. 0: Normal operation 1: Pause cell balancing						
CELL6_EN	Enables the cell balancing switch for CELL6 0: Disabled 1: Enabled						
CELL5_EN	Enables the cell balancing switch for CELL5 0: Disabled 1: Enabled						
CELL4_EN	Enables the cell balancing switch for CELL4 0: Disabled 1: Enabled						
CELL3_EN	Enables the cell balancing switch for CELL3 0: Disabled 1: Enabled						
CELL2_EN	Enables the cell balancing switch for CELL2 0: Disabled 1: Enabled						
CELL1_EN	Enables the cell balancing switch for CELL1 0: Disabled 1: Enabled						

**8.6.1.224 Register: DIAG\_CTRL1**

DIAG_CTRL1 Register Address: 0x116							
B7	B6	B5	B4	B3	B2	B1	B0
LPF_FLT_INJ	AUXDIG_FLT_IN J	SPI_LOOPBACK	FLIP_TR_CRC	OVUV_MODE[1]	OVUV_MODE[0]	OTUT_MODE[1]	OTUT_MODE[0]
0	0	0	0	0	0	0	0
RW	RW	RW	RW	RW	RW	RW	RW
LPF_FLT_INJ	Inject fault condition into comparison circuit between the cell ADC and the redundant low pass filter circuit. 0: Disable 1: Enable						
AUXDIG_FLT_IN J	Inject fault condition into comparison circuit between the aux ADC output and the redundant aux ADC digital circuit. 0: Disable 1: Enable						
SPI_LOOPBACK	Enables SPI loopback function to verify SPI functionality. See the "SPI Master" section for more details. 0: Disable 1: Enable						
FLIP_TR_CRC	Sends a purposely incorrect communication CRC by inverting all of the calculated CRC bits 0: Send CRC as calculated 1: Send inverted CRC						
OVUV_MODE[1:0 J	Selects mode for OV/UV comparators. 00: Round robin for all enabled CELL inputs with automatic BIST 01: Round robin for all enabled CELL inputs 10-11: Single channel (selects lowest number enabled CELL). Make sure to set this bit back to 00 once the OVUV single mode is done.						
OTUT_MODE[1:0 J	Selects mode for OT/UT comparators. 00: Round robin for all enabled GPIO inputs with automatic BIST 01: Round robin for all enabled GPIO inputs 10-11: Single channel (selects lowest number enabled GPIO)						

**8.6.1.225 Register: DIAG\_CTRL2**

DIAG_CTRL2 Register Address: 0x117							
B7	B6	B5	B4	B3	B2	B1	B0
RSVD	AUX_CELL_SEL_ EN	AUX_GPIO_SEL[ 2]	AUX_GPIO_SEL[ 1]	AUX_GPIO_SEL[ 0]	AUX_CELL_SEL[ 2]	AUX_CELL_SEL[ 1]	AUX_CELL_SEL[ 0]
0	0	0	0	0	0	0	0
R	RW	RW	RW	RW	RW	RW	RW
RSVD	Reserved						
AUX_CELL_SEL_ EN	Enables the AUX_CELL_SEL function. Selection for AUX_CELL_SEL is latched when AUX_CELL_SEL_EN is set. This bit needs to be cleared first whenever AUX_CELL_SEL is changed. Set this bit to "0" when the OV_DAC_EN or the UV_DAC_EN in AUX_ADC_CTRL2 are set to 1. 0: AUX_CELL_SEL function disabled 1: Enable AUX_CELL_SEL function						
AUX_GPIO_SEL[ 2:0]	Selects the GPIO for the AUX_FACTCORR* function. 000: No GPIO selected 001: GPIO1 010: GPIO2 011: GPIO3 100: GPIO4 101: GPIO5 110-111: GPIO6						
AUX_CELL_SEL[ 2:0]	Selects cell for and enables AUX_CELL measurement for the auxiliary ADC. Additionally, the VCELL_FACTCORR* registers are set to the cell selected. Any non-zero value for these bits enables the AUX ADC measurement. Set these bits to "000" when the OV_DAC_EN or the UV_DAC_EN in AUX_ADC_CTRL2 are set to 1. 000: No cell selected 001: CELL1 010: CELL2 011: CELL3 100: CELL4 101: CELL5 110-111: CELL6						

**8.6.1.226 Register: DIAG\_CTRL3**

DIAG_CTRL3 Register Address: 0x118							
B7	B6	B5	B4	B3	B2	B1	B0
PUPD_GP4_EN[1:0]	PUPD_GP4_EN[0]	PUPD_GP3_EN[1:0]	PUPD_GP3_EN[0]	PUPD_GP2_EN[1:0]	PUPD_GP2_EN[0]	PUPD_GP1_EN[1:0]	PUPD_GP1_EN[0]
0	0	0	0	0	0	0	0
RW	RW	RW	RW	RW	RW	RW	RW
PUPD_GP4_EN[1:0] Enables the weak pull up/down for GPIO4 while in Analog mode (GPIO4_CONF[PUPD_SEL]=0b000). While GPIO4_CONF[PUPD_SEL] is not 0b000, this setting is ignored. 00: Use GPIO4_CONF[PUPD_SEL] configuration 01: Enables weak pull down for GPIO4 10-11: Enables weak pull up for GPIO4							
PUPD_GP3_EN[1:0] Enables the weak pull up/down for GPIO3 while in Analog mode (GPIO3_CONF[PUPD_SEL]=0b000). While GPIO3_CONF[PUPD_SEL] is not 0b000, this setting is ignored. 00: Use GPIO3_CONF[PUPD_SEL] configuration 01: Enables weak pull down for GPIO3 10-11: Enables weak pull up for GPIO3							
PUPD_GP2_EN[1:0] Enables the weak pull up/down for GPIO2 while in Analog mode (GPIO2_CONF[PUPD_SEL]=0b000). While GPIO2_CONF[PUPD_SEL] is not 0b000, this setting is ignored. 00: Use GPIO2_CONF[PUPD_SEL] configuration 01: Enables weak pull down for GPIO2 10-11: Enables weak pull up for GPIO2							
PUPD_GP1_EN[1:0] Enables the weak pull up/down for GPIO1 while in Analog mode (GPIO1_CONF[PUPD_SEL]=0b000). While GPIO1_CONF[PUPD_SEL] is not 0b000, this setting is ignored. 00: Use GPIO1_CONF[PUPD_SEL] configuration 01: Enables weak pull down for GPIO1 10-11: Enables weak pull up for GPIO1							

**8.6.1.227 Register: DIAG\_CTRL4**

DIAG_CTRL4 Register Address: 0x119							
B7	B6	B5	B4	B3	B2	B1	B0
RSVD	VCFILTSEL	CELUSEL	AUXUSEL	PUPD_GP6_EN[1:0]	PUPD_GP6_EN[0]	PUPD_GP5_EN[1:0]	PUPD_GP5_EN[0]
0	0	0	0	0	0	0	0
R	RW	RW	RW	RW	RW	RW	RW
RSVD Reserved							
VCFILTSEL Selects uncorrected data path for the lowpass filtered cell ADC data instead of the corrected data. This bit is used for data collection when calculating digital filter coefficients for the cell ADCs. 0: Use corrected data for the LPF (normal condition) 1: Use uncorrected data for the LPF							
CELUSEL Selects lowpass filtered uncorrected data instead of single conversion uncorrected data for VCELL_*_U. This bit is used for data collection when calculating digital filter coefficients for the cell ADCs. 0: Use normal uncorrected data (normal condition) 1: Enable LPF for data collection							
AUXUSEL Selects lowpass filtered uncorrected data instead of single conversion uncorrected data for AUX_GPIO1_*. This bit is used for data collection when calculating digital filter coefficients for the AUX ADC. 0: Use normal uncorrected data (normal condition) 1: Enable LPF for data collection. AUXADC becomes continuous measurement mode when AUXUSEL is set 1							
PUPD_GP6_EN[1:0] Enables the weak pull up/down for GPIO6 while in Analog mode (GPIO6_CONF[PUPD_SEL]=0b000). While GPIO6_CONF[PUPD_SEL] is not 0b000, this setting is ignored. 00: Use GPIO6_CONF[PUPD_SEL] configuration 01: Enables weak pull down for GPIO6 10-11: Enables weak pull up for GPIO6							
PUPD_GP5_EN[1:0] Enables the weak pull up/down for GPIO5 while in Analog mode (GPIO5_CONF[PUPD_SEL]=0b000). While GPIO5_CONF[PUPD_SEL] is not 0b000, this setting is ignored. 00: Use GPIO5_CONF[PUPD_SEL] configuration 01: Enables weak pull down for GPIO5 10-11: Enables weak pull up for GPIO5							

**8.6.1.228 Register: VC\_CS\_CTRL**

VC_CS_CTRL Register Address: 0x11A							
B7	B6	B5	B4	B3	B2	B1	B0
RSVD	VC6_CS_EN	VC5_CS_EN	VC4_CS_EN	VC3_CS_EN	VC2_CS_EN	VC1_CS_EN	VC0_CS_EN
0	0	0	0	0	0	0	0
R	RW	RW	RW	RW	RW	RW	RW
RSVD	Reserved						
VC6_CS_EN	Enables current sink for VC6 open-wire tests. 0: Disable 1: Enable						
VC5_CS_EN	Enables current sink for VC5 open-wire tests. 0: Disable 1: Enable						
VC4_CS_EN	Enables current sink for VC4 open-wire tests. 0: Disable 1: Enable						
VC3_CS_EN	Enables current sink for VC3 open-wire tests. 0: Disable 1: Enable						
VC2_CS_EN	Enables current sink for VC2 open-wire tests. 0: Disable 1: Enable						
VC1_CS_EN	Enables current sink for VC1 open-wire tests. 0: Disable 1: Enable						
VC0_CS_EN	Enables current source for VC0 open-wire tests. 0: Disable 1: Enable						

**8.6.1.229 Register: CB\_CS\_CTRL**

CB_CS_CTRL Register Address: 0x11B							
B7	B6	B5	B4	B3	B2	B1	B0
RSVD	CB6_CS_EN	CB5_CS_EN	CB4_CS_EN	CB3_CS_EN	CB2_CS_EN	CB1_CS_EN	CB0_CS_EN
0	0	0	0	0	0	0	0
R	RW	RW	RW	RW	RW	RW	RW
RSVD	Reserved						
CB6_CS_EN	Enables current sink for CB6 open-wire tests. 0: Disable 1: Enable						
CB5_CS_EN	Enables current sink for CB5 open-wire tests. 0: Disable 1: Enable						
CB4_CS_EN	Enables current sink for CB4 open-wire tests. 0: Disable 1: Enable						
CB3_CS_EN	Enables current sink for CB3 open-wire tests. 0: Disable 1: Enable						
CB2_CS_EN	Enables current sink for CB2 open-wire tests. 0: Disable 1: Enable						
CB1_CS_EN	Enables current sink for CB1 open-wire tests. 0: Disable 1: Enable						
CB0_CS_EN	Enables current source for CB0 open-wire tests. 0: Disable 1: Enable						

**8.6.1.230 Register: CBVC\_COMP\_CTRL**

CBVC_COMP_CTRL Register Address: 0x11C							
B7	B6	B5	B4	B3	B2	B1	B0
RSVD[1]	RSVD[0]	CELL6_EN	CELL5_EN	CELL4_EN	CELL3_EN	CELL2_EN	CELL1_EN
0	0	0	0	0	0	0	0
R	R	RW	RW	RW	RW	RW	RW
RSVD[1:0]	Reserved						
CELL6_EN	Enables the cell balancing switch voltage comparator for CELL6. When enabled, the comparator compares the voltage between CB6 and CB5 to the (VC6-VC5)/3. 0: Disable 1: Enable						
CELL5_EN	Enables the cell balancing switch voltage comparator for CELL5. When enabled, the comparator compares the voltage between CB5 and CB4 to the (VC5-VC4)/3. 0: Disable 1: Enable						
CELL4_EN	Enables the cell balancing switch voltage comparator for CELL4. When enabled, the comparator compares the voltage between CB4 and CB3 to the (VC4-VC3)/3. 0: Disable 1: Enable						
CELL3_EN	Enables the cell balancing switch voltage comparator for CELL3. When enabled, the comparator compares the voltage between CB3 and CB2 to the (VC3-VC2)/3. 0: Disable 1: Enable						
CELL2_EN	Enables the cell balancing switch voltage comparator for CELL2. When enabled, the comparator compares the voltage between CB2 and CB1 to the (VC2-VC1)/3. 0: Disable 1: Enable						
CELL1_EN	Enables the cell balancing switch voltage comparator for CELL1. When enabled, the comparator compares the voltage between CB1 and CB0 to the (VC1-VC0)/3. 0: Disable 1: Enable						

**8.6.1.231 Register: ECC\_TEST**

ECC_TEST Register Address: 0x11D							
B7	B6	B5	B4	B3	B2	B1	B0
RSVD[3]	RSVD[2]	RSVD[1]	RSVD[0]	DED_SEC	MANUAL_AUTO	ENC_DEC	ENABLE
0	0	0	0	0	0	0	0
R	R	R	R	RW	RW	RW	RW
RSVD[3:0]	Reserved						
DED_SEC	Sets the decoder function (SEC or DEC) to test. This bit is ignored during manual mode and encoder testing 0: Test SEC functionality. Sets the SYS_FAULT3[SEC_DETECT] flag and outputs (corrected data) to ECC_DATAOUT_n registers. 1: Test DED functionality. Sets the SYS_FAULT3[DED_DETECT] flag. ECC_DATAOUT_n registers read is do not care and should be ignored.						
MANUAL_AUTO	Sets the location of the data to use for the ECC test 0: Auto mode. Use the internal data for test. 1: Manual mode. Uses data in ECC_DATAIN_n registers for test.						
ENC_DEC	Sets the encoder/decoder test to run when ECC_TEST[ENABLE] = 1 0: Run decoder test 1: Run encoder test						
ENABLE	Executes the ECC test. Initiates ECC test set by ECC_TEST. 0: Normal operation, ECC test disabled 1: Initiate test This is NOT auto clear bit. The user has to set it High or Low as needed.						

**8.6.1.232 Register: ECC\_DATAIN0**

ECC_DATAIN0 Register Address: 0x11E							
B7	B6	B5	B4	B3	B2	B1	B0
DATA[7]	DATA[6]	DATA[5]	DATA[4]	DATA[3]	DATA[2]	DATA[1]	DATA[0]
0	0	0	0	0	0	0	0
RW	RW	RW	RW	RW	RW	RW	RW
DATA[7:0]	When ECC enabled in manual mode, ECC_DATAIN_n bytes are used to test the ECC encoder/decoder. If ECC_TEST[ENC_DEC] = 1, ECC_DATAIN7:ECC_DATAIN0 are fed to the encoder. If ECC_TEST[ENC_DEC] = 0, ECC_DATAIN8:ECC_DATAIN0 are fed to the decoder. The ECC_DATAOUT_n bytes must be read back to verify functionality.						

**8.6.1.233 Register: ECC\_DATAIN1**

ECC_DATAIN1 Register Address: 0x11F							
B7	B6	B5	B4	B3	B2	B1	B0
DATA[7]	DATA[6]	DATA[5]	DATA[4]	DATA[3]	DATA[2]	DATA[1]	DATA[0]
0	0	0	0	0	0	0	0
RW	RW	RW	RW	RW	RW	RW	RW
DATA[7:0] When ECC enabled in manual mode, ECC_DATAIN_n bytes are used to test the ECC encoder/decoder. If ECC_TEST[ENC_DEC] = 1, ECC_DATAIN7:ECC_DATAIN0 are fed to the encoder. If ECC_TEST[ENC_DEC] = 0, ECC_DATAIN8:ECC_DATAIN0 are fed to the decoder. The ECC_DATAOUT_n bytes must be read back to verify functionality.							

**8.6.1.234 Register: ECC\_DATAIN2**

ECC_DATAIN2 Register Address: 0x120							
B7	B6	B5	B4	B3	B2	B1	B0
DATA[7]	DATA[6]	DATA[5]	DATA[4]	DATA[3]	DATA[2]	DATA[1]	DATA[0]
0	0	0	0	0	0	0	0
RW	RW	RW	RW	RW	RW	RW	RW
DATA[7:0] When ECC enabled in manual mode, ECC_DATAIN_n bytes are used to test the ECC encoder/decoder. If ECC_TEST[ENC_DEC] = 1, ECC_DATAIN7:ECC_DATAIN0 are fed to the encoder. If ECC_TEST[ENC_DEC] = 0, ECC_DATAIN8:ECC_DATAIN0 are fed to the decoder. The ECC_DATAOUT_n bytes must be read back to verify functionality.							

**8.6.1.235 Register: ECC\_DATAIN3**

ECC_DATAIN3 Register Address: 0x121							
B7	B6	B5	B4	B3	B2	B1	B0
DATA[7]	DATA[6]	DATA[5]	DATA[4]	DATA[3]	DATA[2]	DATA[1]	DATA[0]
0	0	0	0	0	0	0	0
RW	RW	RW	RW	RW	RW	RW	RW
DATA[7:0] When ECC enabled in manual mode, ECC_DATAIN_n bytes are used to test the ECC encoder/decoder. If ECC_TEST[ENC_DEC] = 1, ECC_DATAIN7:ECC_DATAIN0 are fed to the encoder. If ECC_TEST[ENC_DEC] = 0, ECC_DATAIN8:ECC_DATAIN0 are fed to the decoder. The ECC_DATAOUT_n bytes must be read back to verify functionality.							

**8.6.1.236 Register: ECC\_DATAIN4**

ECC_DATAIN4 Register Address: 0x122							
B7	B6	B5	B4	B3	B2	B1	B0
DATA[7]	DATA[6]	DATA[5]	DATA[4]	DATA[3]	DATA[2]	DATA[1]	DATA[0]
0	0	0	0	0	0	0	0
RW	RW	RW	RW	RW	RW	RW	RW
DATA[7:0] When ECC enabled in manual mode, ECC_DATAIN_n bytes are used to test the ECC encoder/decoder. If ECC_TEST[ENC_DEC] = 1, ECC_DATAIN7:ECC_DATAIN0 are fed to the encoder. If ECC_TEST[ENC_DEC] = 0, ECC_DATAIN8:ECC_DATAIN0 are fed to the decoder. The ECC_DATAOUT_n bytes must be read back to verify functionality.							

**8.6.1.237 Register: ECC\_DATAIN5**

ECC_DATAIN5 Register Address: 0x123							
B7	B6	B5	B4	B3	B2	B1	B0
DATA[7]	DATA[6]	DATA[5]	DATA[4]	DATA[3]	DATA[2]	DATA[1]	DATA[0]
0	0	0	0	0	0	0	0
RW	RW	RW	RW	RW	RW	RW	RW
DATA[7:0] When ECC enabled in manual mode, ECC_DATAIN_n bytes are used to test the ECC encoder/decoder. If ECC_TEST[ENC_DEC] = 1, ECC_DATAIN7:ECC_DATAIN0 are fed to the encoder. If ECC_TEST[ENC_DEC] = 0, ECC_DATAIN8:ECC_DATAIN0 are fed to the decoder. The ECC_DATAOUT_n bytes must be read back to verify functionality.							

**8.6.1.238 Register: ECC\_DATAIN6**

ECC_DATAIN6 Register Address: 0x124							
B7	B6	B5	B4	B3	B2	B1	B0
DATA[7]	DATA[6]	DATA[5]	DATA[4]	DATA[3]	DATA[2]	DATA[1]	DATA[0]
0	0	0	0	0	0	0	0
RW	RW	RW	RW	RW	RW	RW	RW
DATA[7:0] When ECC enabled in manual mode, ECC_DATAIN_n bytes are used to test the ECC encoder/decoder. If ECC_TEST[ENC_DEC] = 1, ECC_DATAIN7:ECC_DATAIN0 are fed to the encoder. If ECC_TEST[ENC_DEC] = 0, ECC_DATAIN8:ECC_DATAIN0 are fed to the decoder. The ECC_DATAOUT_n bytes must be read back to verify functionality.							

**8.6.1.239 Register: ECC\_DATAIN7**

ECC_DATAIN7 Register Address: 0x125							
B7	B6	B5	B4	B3	B2	B1	B0
DATA[7]	DATA[6]	DATA[5]	DATA[4]	DATA[3]	DATA[2]	DATA[1]	DATA[0]
0	0	0	0	0	0	0	0
RW	RW	RW	RW	RW	RW	RW	RW
DATA[7:0] When ECC enabled in manual mode, ECC_DATAIN_n bytes are used to test the ECC encoder/decoder. If ECC_TEST[ENC_DEC] = 1, ECC_DATAIN7:ECC_DATAIN0 are fed to the encoder. If ECC_TEST[ENC_DEC] = 0, ECC_DATAIN8:ECC_DATAIN0 are fed to the decoder. The ECC_DATAOUT_n bytes must be read back to verify functionality.							

**8.6.1.240 Register: ECC\_DATAIN8**

ECC_DATAIN8 Register Address: 0x126							
B7	B6	B5	B4	B3	B2	B1	B0
DATA[7]	DATA[6]	DATA[5]	DATA[4]	DATA[3]	DATA[2]	DATA[1]	DATA[0]
0	0	0	0	0	0	0	0
RW	RW	RW	RW	RW	RW	RW	RW
DATA[7:0] When ECC enabled in manual mode, ECC_DATAIN_n bytes are used to test the ECC encoder/decoder. If ECC_TEST[ENC_DEC] = 1, ECC_DATAIN7:ECC_DATAIN0 are fed to the encoder. If ECC_TEST[ENC_DEC] = 0, ECC_DATAIN8:ECC_DATAIN0 are fed to the decoder. The ECC_DATAOUT_n bytes must be read back to verify functionality.							



**8.6.1.241 Register: GPIO\_FLT\_RST**

GPIO_FLT_RST Register Address: 0x127							
B7	B6	B5	B4	B3	B2	B1	B0
RSVD[1]	RSVD[0]	GPIO6_RST	GPIO5_RST	GPIO4_RST	GPIO3_RST	GPIO2_RST	GPIO1_RST
0	0	0	0	0	0	0	0
R	R	RW	RW	RW	RW	RW	RW
RSVD[1:0]	reserved						
GPIO6_RST	Resets GPIO_FAULT[GPIO6] to '0' 0: Do not reset 1: Reset Always reads '0'						
GPIO5_RST	Resets GPIO_FAULT[GPIO5] to '0' 0: Do not reset 1: Reset Always reads '0'						
GPIO4_RST	Resets GPIO_FAULT[GPIO4] to '0' 0: Do not reset 1: Reset Always reads '0'						
GPIO3_RST	Resets GPIO_FAULT[GPIO3] to '0' 0: Do not reset 1: Reset Always reads '0'						
GPIO2_RST	Resets GPIO_FAULT[GPIO2] to '0' 0: Do not reset 1: Reset Always reads '0'						
GPIO1_RST	Resets GPIO_FAULT[GPIO1] to '0' 0: Do not reset 1: Reset Always reads '0'						

**8.6.1.242 Register: UV\_FLT\_RST**

UV_FLT_RST Register Address: 0x128							
B7	B6	B5	B4	B3	B2	B1	B0
RSVD[1]	RSVD[0]	CELL6_RST	CELL5_RST	CELL4_RST	CELL3_RST	CELL2_RST	CELL1_RST
0	0	0	0	0	0	0	0
R	R	RW	RW	RW	RW	RW	RW
RSVD[1:0]	Reserved						
CELL6_RST	Resets UV_FAULT[CELL6] to '0' 0: Do not reset 1: Reset Always reads '0'						
CELL5_RST	Resets UV_FAULT[CELL5] to '0' 0: Do not reset 1: Reset Always reads '0'						
CELL4_RST	Resets UV_FAULT[CELL4] to '0' 0: Do not reset 1: Reset Always reads '0'						
CELL3_RST	Resets UV_FAULT[CELL3] to '0' 0: Do not reset 1: Reset Always reads '0'						
CELL2_RST	Resets UV_FAULT[CELL2] to '0' 0: Do not reset 1: Reset Always reads '0'						
CELL1_RST	Resets UV_FAULT[CELL1] to '0' 0: Do not reset 1: Reset Always reads '0'						

**8.6.1.243 Register: OV\_FLT\_RST**

OV_FLT_RST Register Address: 0x129							
B7	B6	B5	B4	B3	B2	B1	B0
RSVD[1]	RSVD[0]	CELL6_RST	CELL5_RST	CELL4_RST	CELL3_RST	CELL2_RST	CELL1_RST
0	0	0	0	0	0	0	0
R	R	RW	RW	RW	RW	RW	RW
RSVD[1:0]		Reserved					
CELL6_RST		Resets OV_FAULT[CELL6] to'0' 0: Do not reset 1: Reset Always reads '0'					
CELL5_RST		Resets OV_FAULT[CELL5] to'0' 0: Do not reset 1: Reset Always reads '0'					
CELL4_RST		Resets OV_FAULT[CELL4] to'0' 0: Do not reset 1: Reset Always reads '0'					
CELL3_RST		Resets OV_FAULT[CELL3] to'0' 0: Do not reset 1: Reset Always reads '0'					
CELL2_RST		Resets OV_FAULT[CELL2] to'0' 0: Do not reset 1: Reset Always reads '0'					
CELL1_RST		Resets OV_FAULT[CELL1] to'0' 0: Do not reset 1: Reset Always reads '0'					

**8.6.1.244 Register: UT\_FLT\_RST**

UT_FLT_RST Register Address: 0x12A							
B7	B6	B5	B4	B3	B2	B1	B0
RSVD[1]	RSVD[0]	GPIO6_RST	GPIO5_RST	GPIO4_RST	GPIO3_RST	GPIO2_RST	GPIO1_RST
0	0	0	0	0	0	0	0
R	R	RW	RW	RW	RW	RW	RW
RSVD[1:0]		Reserved					
GPIO6_RST		Resets UT_FAULT[GPIO6] to'0' 0: Do not reset 1: Reset Always reads '0'					
GPIO5_RST		Resets UT_FAULT[GPIO5] to'0' 0: Do not reset 1: Reset Always reads '0'					
GPIO4_RST		Resets UT_FAULT[GPIO4] to'0' 0: Do not reset 1: Reset Always reads '0'					
GPIO3_RST		Resets UT_FAULT[GPIO3] to'0' 0: Do not reset 1: Reset Always reads '0'					
GPIO2_RST		Resets UT_FAULT[GPIO2] to'0' 0: Do not reset 1: Reset Always reads '0'					
GPIO1_RST		Resets UT_FAULT[GPIO1] to'0' 0: Do not reset 1: Reset Always reads '0'					

**8.6.1.245 Register: OT\_FLT\_RST**

OT_FLT_RST Register Address: 0x12B							
B7	B6	B5	B4	B3	B2	B1	B0
RSVD[1]	RSVD[0]	GPIO6_RST	GPIO5_RST	GPIO4_RST	GPIO3_RST	GPIO2_RST	GPIO1_RST
0	0	0	0	0	0	0	0
R	R	RW	RW	RW	RW	RW	RW
RSVD[1:0]		reserved					
GPIO6_RST		Resets OT_FAULT[GPIO6] to'0' 0: Do not reset 1: Reset Always reads '0'					
GPIO5_RST		Resets OT_FAULT[GPIO5] to'0' 0: Do not reset 1: Reset Always reads '0'					
GPIO4_RST		Resets OT_FAULT[GPIO4] to'0' 0: Do not reset 1: Reset Always reads '0'					
GPIO3_RST		Resets OT_FAULT[GPIO3] to'0' 0: Do not reset 1: Reset Always reads '0'					
GPIO2_RST		Resets OT_FAULT[GPIO2] to'0' 0: Do not reset 1: Reset Always reads '0'					
GPIO1_RST		Resets OT_FAULT[GPIO1] to'0' 0: Do not reset 1: Reset Always reads '0'					

**8.6.1.246 Register: TONE\_FLT\_RST**

TONE_FLT_RST Register Address: 0x12C							
B7	B6	B5	B4	B3	B2	B1	B0
RSVD[4]	RSVD[3]	RSVD[2]	RSVD[1]	RSVD[0]	FF_REC_RST	HB_FAIL_RST	HB_FAST_RST
0	0	0	0	0	0	0	0
R	R	R	R	R	RW	RW	RW
RSVD[4:0]		reserved					
FF_REC_RST		Resets TONE_FAULT[FF_REC] to'0' 0: Do not reset 1: Reset Always reads '0'					
HB_FAIL_RST		Resets TONE_FAULT[HB_FAIL] to'0' 0: Do not reset 1: Reset Always reads '0'					
HB_FAST_RST		Resets TONE_FAULT[HB_FAST] to'0' 0: Do not reset 1: Reset Always reads '0'					

**8.6.1.247 Register: COMM\_UART\_FLT\_RST**

COMM_UART_FLT_RST Register Address: 0x12D							
B7	B6	B5	B4	B3	B2	B1	B0
RSVD[4]	RSVD[3]	RSVD[2]	RSVD[1]	RSVD[0]	COMMCLR_RST	COMMRST_RST	STOP_RST
0	0	0	0	0	0	0	0
R	R	R	R	R	RW	RW	RW
RSVD[4:0]		reserved					
COMMCLR_RST	Resets COMM_UART_FAULT[COMMCLR_DET] to '0' 0: Do not reset 1: Reset Always reads '0'						
COMMRST_RST	Resets COMM_UART_FAULT[COMMRST_DET] to '0' 0: Do not reset 1: Reset Always reads '0'						
STOP_RST	Resets COMM_UART_FAULT[STOP] to '0' 0: Do not reset 1: Reset Always reads '0'						

**8.6.1.248 Register: COMM\_UART\_RC\_FLT\_RST**

COMM_UART_RC_FLT_RST Register Address: 0x12E							
B7	B6	B5	B4	B3	B2	B1	B0
RSVD[1]	RSVD[0]	IERR_RST	TXDIS_RST	SOF_RST	BERR_RST	UNEXP_RST	CRC_RST
0	0	0	0	0	0	0	0
R	R	RW	RW	RW	RW	RW	RW
RSVD[1:0]		reserved					
IERR_RST	Resets COMM_UART_RC_FAULT[IERR] to '0' 0: Do not reset 1: Reset Always reads '0'						
TXDIS_RST	Resets COMM_UART_RC_FAULT[TXDIS] to '0' 0: Do not reset 1: Reset Always reads '0'						
SOF_RST	Resets COMM_UART_RC_FAULT[SOF] to '0' 0: Do not reset 1: Reset Always reads '0'						
BERR_RST	Resets COMM_UART_RC_FAULT[BERR] to '0' 0: Do not reset 1: Reset Always reads '0'						
UNEXP_RST	Resets COMM_UART_RC_FAULT[UNEXP] to '0' 0: Do not reset 1: Reset Always reads '0'						
CRC_RST	Resets COMM_UART_RC_FAULT[CRC] to '0' 0: Do not reset 1: Reset Always reads '0'						

**8.6.1.249 Register: COMM\_UART\_RR\_FLT\_RST**

COMM_UART_RR_FLT_RST Register Address: 0x12F							
B7	B6	B5	B4	B3	B2	B1	B0
RSVD[1]	RSVD[0]	SPARE	SPARE	SOF_RST	BERR_RST	RSVD	CRC_RST
0	0	0	0	0	0	0	0
R	R	RW	RW	RW	RW	RW	RW
RSVD[1:0]	Reserved						
SPARE	Spare						
SPARE	Spare						
SOF_RST	Resets COMM_UART_RR_FAULT[SOF] to '0' 0: Do not reset 1: Reset Always reads '0'						
BERR_RST	Resets COMM_UART_RR_FAULT[BERR] to '0' 0: Do not reset 1: Reset Always reads '0'						
RSVD	Reserved						
CRC_RST	Resets COMM_UART_RR_FAULT[CRC] to '0' 0: Do not reset 1: Reset Always reads '0'						

**8.6.1.250 Register: COMM\_UART\_TR\_FLT\_RST**

COMM_UART_TR_FLT_RST Register Address: 0x130							
B7	B6	B5	B4	B3	B2	B1	B0
RSVD[5]	RSVD[4]	RSVD[3]	RSVD[2]	RSVD[1]	RSVD[0]	SOF_RST	WAIT_RST
0	0	0	0	0	0	0	0
R	R	R	R	R	R	rw	RW
RSVD[5:0]	Reserved						
SOF_RST	Resets COMM_UART_TR_FAULT[SOF] to '0' 0: Do not reset 1: Reset Always reads '0'						
WAIT_RST	Resets COMM_UART_TR_FAULT[WAIT] to '0' 0: Do not reset 1: Reset Always reads '0'						

**8.6.1.251 Register: COMM\_COMH\_FLT\_RST**

COMM_COMH_FLT_RST Register Address: 0x131							
B7	B6	B5	B4	B3	B2	B1	B0
RSVD[1]	RSVD[0]	BERR_RST	DATA_MISS_RST	DATA_ORDER_RST	SYNC2_RST	SYNC1_RST	BIT_RST
0	0	0	0	0	0	0	0
R	R	RW	RW	RW	RW	RW	RW
RSVD[1:0]		reserved					
BERR_RST	Resets COMM_COMH_FAULT[BERR] to '0' 0: Do not reset 1: Reset Always reads '0'						
DATA_MISS_RST	Resets COMM_COMH_FAULT[DATA_MISS] to '0' 0: Do not reset 1: Reset Always reads '0'						
DATA_ORDER_RST	Resets COMM_COMH_FAULT[DATA_ORDER] to '0' 0: Do not reset 1: Reset Always reads '0'						
SYNC2_RST	Resets COMM_COMH_FAULT[SYNC2] to '0' 0: Do not reset 1: Reset Always reads '0'						
SYNC1_RST	Resets COMM_COMH_FAULT[SYNC1] to '0' 0: Do not reset 1: Reset Always reads '0'						
BIT_RST	Resets COMM_COMH_FAULT[BIT] to '0' 0: Do not reset 1: Reset Always reads '0'						

**8.6.1.252 Register: COMM\_COMH\_RC\_FLT\_RST**

COMM_COMH_RC_FLT_RST Register Address: 0x132							
B7	B6	B5	B4	B3	B2	B1	B0
RSVD[1]	RSVD[0]	IERR_RST	TXDIS_RST	SOF_RST	BERR_RST	UNEXP_RST	CRC_RST
0	0	0	0	0	0	0	0
R	R	RW	RW	RW	RW	RW	RW
RSVD[1:0]		reserved					
IERR_RST	Resets COMM_COMH_RC_FAULT[IERR] to '0' 0: Do not reset 1: Reset Always reads '0'						
TXDIS_RST	Resets COMM_COMH_RC_FAULT[TXDIS] to '0' 0: Do not reset 1: Reset Always reads '0'						
SOF_RST	Resets COMM_COMH_RC_FAULT[SOF] to '0' 0: Do not reset 1: Reset Always reads '0'						
BERR_RST	Resets COMM_COMH_RC_FAULT[BERR] to '0' 0: Do not reset 1: Reset Always reads '0'						
UNEXP_RST	Resets COMM_COMH_RC_FAULT[UNEXP] to '0' 0: Do not reset 1: Reset Always reads '0'						
CRC_RST	Resets COMM_COMH_RC_FAULT[CRC] to '0' 0: Do not reset 1: Reset Always reads '0'						

**8.6.1.253 Register: COMM\_COMH\_RR\_FLT\_RST**

COMM_COMH_RR_FLT_RST Register Address: 0x133							
B7	B6	B5	B4	B3	B2	B1	B0
RSVD[1]	RSVD[0]	SPARE	TXDIS_RST	SOF_RST	BERR_RST	UNEXP_RST	CRC_RST
0	0	0	0	0	0	0	0
R	R	RW	RW	RW	RW	RW	RW
RSVD[1:0]	Reserved						
SPARE	Spare						
TXDIS_RST	Resets COMM_COMH_RR_FAULT[TXDIS] to '0' 0: Do not reset 1: Reset Always reads '0'						
SOF_RST	Resets COMM_COMH_RR_FAULT[SOF] to '0' 0: Do not reset 1: Reset Always reads '0'						
BERR_RST	Resets COMM_COMH_RR_FAULT[BERR] to '0' 0: Do not reset 1: Reset Always reads '0'						
UNEXP_RST	Resets COMM_COMH_RR_FAULT[UNEXP] to '0' 0: Do not reset 1: Reset Always reads '0'						
CRC_RST	Resets COMM_COMH_RR_FAULT[CRC] to '0' 0: Do not reset 1: Reset Always reads '0'						

**8.6.1.254 Register: COMM\_COMH\_TR\_FLT\_RST**

COMM_COMH_TR_FLT_RST Register Address: 0x134							
B7	B6	B5	B4	B3	B2	B1	B0
RSVD[5]	RSVD[4]	RSVD[3]	RSVD[2]	RSVD[1]	RSVD[0]	SPARE	WAIT_RST
0	0	0	0	0	0	0	0
R	R	R	R	R	R	RW	RW
RSVD[5:0]	reserved						
SPARE	Spare						
WAIT_RST	Resets COMM_COMH_TR_FAULT[WAIT] to '0' 0: Do not reset 1: Reset Always reads '0'						

**8.6.1.255 Register: COMM\_COML\_FLT\_RST**

COMM_COML_FLT_RST Register Address: 0x135							
B7	B6	B5	B4	B3	B2	B1	B0
RSVD[1]	RSVD[0]	BERR_RST	DATA_MISS_RST	DATA_ORDER_RST	SYNC2_RST	SYNC1_RST	BIT_RST
0	0	0	0	0	0	0	0
R	R	RW	RW	RW	RW	RW	RW
RSVD[1:0]		reserved					
BERR_RST	Resets COMM_COML_FAULT[BERR] to '0' 0: Do not reset 1: Reset Always reads '0'						
DATA_MISS_RST	Resets COMM_COML_FAULT[DATA_MISS] to '0' 0: Do not reset 1: Reset Always reads '0'						
DATA_ORDER_RST	Resets COMM_COML_FAULT[DATA_ORDER] to '0' 0: Do not reset 1: Reset Always reads '0'						
SYNC2_RST	Resets COMM_COML_FAULT[SYNC2] to '0' 0: Do not reset 1: Reset Always reads '0'						
SYNC1_RST	Resets COMM_COML_FAULT[SYNC1] to '0' 0: Do not reset 1: Reset Always reads '0'						
BIT_RST	Resets COMM_COML_FAULT[BIT] to '0' 0: Do not reset 1: Reset Always reads '0'						

**8.6.1.256 Register: COMM\_COML\_RC\_FLT\_RST**

COMM_COML_RC_FLT_RST Register Address: 0x136							
B7	B6	B5	B4	B3	B2	B1	B0
RSVD[1]	RSVD[0]	IERR_RST	TXDIS_RST	SOF_RST	BERR_RST	UNEXP_RST	CRC_RST
0	0	0	0	0	0	0	0
R	R	RW	RW	RW	RW	RW	RW
RSVD[1:0]		reserved					
IERR_RST	Resets COMM_COML_RC_FAULT[IERR] to '0' 0: Do not reset 1: Reset Always reads '0'						
TXDIS_RST	Resets COMM_COML_RC_FAULT[TXDIS] to '0' 0: Do not reset 1: Reset Always reads '0'						
SOF_RST	Resets COMM_COML_RC_FAULT[SOF] to '0' 0: Do not reset 1: Reset Always reads '0'						
BERR_RST	Resets COMM_COML_RC_FAULT[BERR] to '0' 0: Do not reset 1: Reset Always reads '0'						
UNEXP_RST	Resets COMM_COML_RC_FAULT[UNEXP] to '0' 0: Do not reset 1: Reset Always reads '0'						
CRC_RST	Resets COMM_COML_RC_FAULT[CRC] to '0' 0: Do not reset 1: Reset Always reads '0'						



**8.6.1.257 Register: COMM\_COML\_RR\_FLT\_RST**

COMM_COML_RR_FLT_RST Register Address: 0x137							
B7	B6	B5	B4	B3	B2	B1	B0
RSVD[1]	RSVD[0]	RSVD	TXDIS_RST	SOF_RST	BERR_RST	UNEXP_RST	CRC_RST
0	0	0	0	0	0	0	0
R	R	RW	RW	RW	RW	RW	RW
RSVD[1:0]	reserved						
RSVD	reserved						
TXDIS_RST	Resets COMM_COML_RR_FAULT[TXDIS] to '0' 0: Do not reset 1: Reset Always reads '0'						
SOF_RST	Resets COMM_COML_RR_FAULT[SOF] to '0' 0: Do not reset 1: Reset Always reads '0'						
BERR_RST	Resets COMM_COML_RR_FAULT[BERR] to '0' 0: Do not reset 1: Reset Always reads '0'						
UNEXP_RST	Resets COMM_COML_RR_FAULT[UNEXP] to '0' 0: Do not reset 1: Reset Always reads '0'						
CRC_RST	Resets COMM_COML_RR_FAULT[CRC] to '0' 0: Do not reset 1: Reset Always reads '0'						

**8.6.1.258 Register: COMM\_COML\_TR\_FLT\_RST**

COMM_COML_TR_FLT_RST Register Address: 0x138							
B7	B6	B5	B4	B3	B2	B1	B0
RSVD[5]	RSVD[4]	RSVD[3]	RSVD[2]	RSVD[1]	RSVD[0]	RSVD	WAIT_RST
0	0	0	0	0	0	0	0
R	R	R	R	R	R	RW	RW
RSVD[5:0]	Reserved						
RSVD	Reserved						
WAIT_RST	Resets COMM_COML_TR_FAULT[WAIT] to '0' 0: Do not reset 1: Reset Always reads '0'						

**8.6.1.259 Register: OTP\_FLT\_RST**

OTP_FLT_RST Register Address: 0x139							
B7	B6	B5	B4	B3	B2	B1	B0
RSVD[4]	RSVD[3]	RSVD[2]	RSVD[1]	RSVD[0]	CUSTLDERR_RST	FACTLDERR_RST	GBLOVERR_RST
0	0	0	0	0	0	0	0
R	R	R	R	R	RW	RW	RW
RSVD[4:0]		reserved					
CUSTLDERR_RST	Resets OTP_FAULT[CUSTLDERR] to '0' 0: Do not reset 1: Reset Always reads '0'. The OTP load faults, user must attempt a reset the device again to see if the faults are still there as these faults are generated only once after reset when OTP load is attempted.						
FACTLDERR_RST	Resets OTP_FAULT[FACTLDERR] to '0' 0: Do not reset 1: Reset Always reads '0'. The OTP load faults, user must attempt a reset the device again to see if the faults are still there as these faults are generated only once after reset when OTP load is attempted.						
GBLOVERR_RST	Resets OTP_FAULT[GBLOVRERR] to '0' 0: Do not reset 1: Reset Always reads '0'. The OTP load faults, user must attempt a reset the device again to see if the faults are still there as these faults are generated only once after reset when OTP load is attempted.						

**8.6.1.260 Register: RAIL\_FLT\_RST**

RAIL_FLT_RST Register Address: 0x13A							
B7	B6	B5	B4	B3	B2	B1	B0
AVDD_REFUV_RST	TSREFOV_RST	TSREFUV_RST	VLDOOV_RST	CVDDUV_RST	DVDDOV_RST	AVDDOV_RST	AVDDUV_DRST_RST
0	0	0	0	0	0	0	0
RW	RW	RW	RW	RW	RW	RW	RW
AVDD_REFUV_RST	Resets RAIL_FAULT[AVDD_REFUV] to '0' 0: Do not reset 1: Reset Always reads '0'						
TSREFOV_RST	Resets RAIL_FAULT[TSREFOV] to '0' 0: Do not reset 1: Reset Always reads '0'						
TSREFUV_RST	Resets RAIL_FAULT[TSREFUV] to '0' 0: Do not reset 1: Reset Always reads '0'						
VLDOOV_RST	Resets RAIL_FAULT[VLDOOV] to '0' 0: Do not reset 1: Reset Always reads '0'						
CVDDUV_RST	Resets RAIL_FAULT[CVDDUV] to '0' 0: Do not reset 1: Reset Always reads '0'						
DVDDOV_RST	Resets RAIL_FAULT[DVDDOV] to '0' 0: Do not reset 1: Reset Always reads '0'						
AVDDOV_RST	Resets RAIL_FAULT[AVDDOV] to '0' 0: Do not reset 1: Reset Always reads '0'						
AVDDUV_DRST_RST	Resets RAIL_FAULT[AVDDUV_DRST] to '0' 0: Do not reset 1: Reset Always reads '0'						

**8.6.1.261 Register: SYS\_FLT1\_RST**

SYS_FLT1_RST Register Address: 0x13B							
B7	B6	B5	B4	B3	B2	B1	B0
SPARE	TWARN_RST	Reserved	CTS_RST	TSD_RST	AVDD_REFUV_D RST_RST	AVAO_REF_OV_ RST	DRST_RST
0	0	0	0	0	0	0	0
R	RW	RW	RW	RW	RW	RW	RW
SPARE	Spare						
TWARN_RST	Resets SYS_FAULT1[TWARN] to '0' 0: Do not reset 1: Reset Always reads '0'						
Reserved	Reserved						
CTS_RST	Resets SYS_FAULT1[CTS] to '0' 0: Do not reset 1: Reset Always reads '0'						
TSD_RST	Resets SYS_FAULT1[TSD] to '0' 0: Do not reset 1: Reset Always reads '0'						
AVDD_REFUV_D RST_RST	Resets SYS_FAULT1[AVDD_REFUV_DRST] to '0' 0: Do not reset 1: Reset Always reads '0'						
AVAO_REF_OV_ RST	Resets SYS_FAULT1[AVAO_REF_OV] to '0' 0: Do not reset 1: Reset Always reads '0'						
DRST_RST	Resets SYS_FAULT1[DRST] to '0' 0: Do not reset 1: Reset Always reads '0'						

**8.6.1.262 Register: SYS\_FLT2\_RST**

SYS_FLT2_RST Register Address: 0x13C							
B7	B6	B5	B4	B3	B2	B1	B0
SHTDWN_REC_RST	CVSS_OPEN_RST	DVSS_OPEN_RST	AVDD_OSC_RST	TSREF_OSC_RST	REF1_OSC_RST	FACT_CRC_RST	CUST_CRC_RST
0	0	0	0	0	0	0	0
RW	RW	RW	RW	RW	RW	RW	RW
SHTDWN_REC_RST	Resets SYS_FAULT2[SHTDWN_REC] to '0' 0: Do not reset 1: Reset Always reads '0'						
CVSS_OPEN_RST	Resets SYS_FAULT2[CVSS_OPEN] to '0' 0: Do not reset 1: Reset Always reads '0'						
DVSS_OPEN_RST	Resets SYS_FAULT2[DVSS_OPEN] to '0' 0: Do not reset 1: Reset Always reads '0'						
AVDD_OSC_RST	Resets SYS_FAULT2[AVDD_OSC] to '0' 0: Do not reset 1: Reset Always reads '0'						
TSREF_OSC_RST	Resets SYS_FAULT2[TSREF_OSC] to '0' 0: Do not reset 1: Reset Always reads '0'						
REF1_OSC_RST	Resets SYS_FAULT2[REF1_OSC] to '0' 0: Do not reset 1: Reset Always reads '0'						
FACT_CRC_RST	Resets SYS_FAULT2[FACT_CRC] to '0' 0: Do not reset 1: Reset Always reads '0'						
CUST_CRC_RST	Resets SYS_FAULT2[CUST_CRC] to '0' 0: Do not reset 1: Reset Always reads '0'						

**8.6.1.263 Register: SYS\_FLT3\_RST**

SYS_FLT3_RST Register Address: 0x13D							
B7	B6	B5	B4	B3	B2	B1	B0
RSVD	AUX_FILT_RST	LP_FILT_RST	VIOUV_RST	CB_VDONE_RST	LFO_RST	SEC_DET_RST	DED_DET_RST
0	0	0	0	0	0	0	0
R	rw	rw	RW	RW	rw	RW	RW
RSVD	Reserved						
AUX_FILT_RST	Resets SYS_FAULT3[AUX_FILT] to '0' 0: Do not reset 1: Reset Always reads '0'						
LP_FILT_RST	Resets SYS_FAULT3[LP_FILT] to '0' 0: Do not reset 1: Reset Always reads '0'						
VIOUV_RST	Resets SYS_FAULT3[VIOUV_RST] to '0' 0: Do not reset 1: Reset Always reads '0'						
CB_VDONE_RST	Resets SYS_FAULT3[CB_VDONE] to '0' 0: Do not reset 1: Reset Always reads '0'						
LFO_RST	Resets SYS_FAULT3[LFO] to '0' 0: Do not reset 1: Reset Always reads '0'						
SEC_DET_RST	Resets SYS_FAULT3[SEC_DETECT] to '0' 0: Do not reset 1: Reset Always reads '0'						
DED_DET_RST	Resets SYS_FAULT3[DED_DETECT] to '0' 0: Do not reset 1: Reset Always reads '0'						

**8.6.1.264 Register: OVUV\_BIST\_FLT\_RST**

OVUV_BIST_FLT_RST Register Address: 0x13E							
B7	B6	B5	B4	B3	B2	B1	B0
RSVD[5]	RSVD[4]	RSVD[3]	RSVD[2]	RSVD[1]	RSVD[0]	OVCOMP_RST	UVCOMP_RST
0	0	0	0	0	0	0	0
R	R	R	R	R	R	RW	RW
RSVD[5:0]	Reserved						
OVCOMP_RST	Resets OVUV_BIST_FAULT[OVCOMP] to '0' 0: Do not reset 1: Reset Always reads '0'						
UVCOMP_RST	Resets OVUV_BIST_FAULT[UVCOMP] to '0' 0: Do not reset 1: Reset Always reads '0'						

**8.6.1.265 Register: OTUT\_BIST\_FLT\_RST**

OTUT_BIST_FLT_RST Register Address: 0x13F							
B7	B6	B5	B4	B3	B2	B1	B0
MUX6_RST	MUX5_RST	MUX4_RST	MUX3_RST	MUX2_RST	MUX1_RST	UTCOMP_RST	OTCOMP_RST
0	0	0	0	0	0	0	0
RW	RW	RW	RW	RW	RW	RW	RW
MUX6_RST	Resets OTUT_BIST_FAULT[MUX6] to '0' 0: Do not reset 1: Reset Always reads '0'						
MUX5_RST	Resets OTUT_BIST_FAULT[MUX5] to '0' 0: Do not reset 1: Reset Always reads '0'						
MUX4_RST	Resets OTUT_BIST_FAULT[MUX4] to '0' 0: Do not reset 1: Reset Always reads '0'						
MUX3_RST	Resets OTUT_BIST_FAULT[MUX3] to '0' 0: Do not reset 1: Reset Always reads '0'						
MUX2_RST	Resets OTUT_BIST_FAULT[MUX2] to '0' 0: Do not reset 1: Reset Always reads '0'						
MUX1_RST	Resets OTUT_BIST_FAULT[MUX1] to '0' 0: Do not reset 1: Reset Always reads '0'						
UTCOMP_RST	Resets OTUT_BIST_FAULT[UTCOMP] to '0' 0: Do not reset 1: Reset Always reads '0'						
OTCOMP_RST	Resets OTUT_BIST_FAULT[OTCOMP] to '0' 0: Do not reset 1: Reset Always reads '0'						

**8.6.1.266 Register: OTP\_PROG\_UNLOCK2A**

OTP_PROG_UNLOCK2A Register Address: 0x150							
B7	B6	B5	B4	B3	B2	B1	B0
UNLOCK[7]	UNLOCK[6]	UNLOCK[5]	UNLOCK[4]	UNLOCK[3]	UNLOCK[2]	UNLOCK[1]	UNLOCK[0]
0	0	0	0	0	0	0	0
RW	RW	RW	RW	RW	RW	RW	RW
UNLOCK[7:0]	Second of two confirmation commands required before OTP programming. Must be written in sequence from OTP_PROG_UNLOCK2A to OTP_PROG_UNLOCK2D (OTP_PROG_UNLOCK2A > OTP_PROG_UNLOCK2B > OTP_PROG_UNLOCK2C > OTP_PROG_UNLOCK2D). Always returns 0x00 when read. Once the correct sequence is entered and the OTP is unlocked, the next write clears the lock condition. The write following the final unlock command must be to OTP_PROG_CTRL[PROG_GO] to program the OTP.						

**8.6.1.267 Register: OTP\_PROG\_UNLOCK2B**

OTP_PROG_UNLOCK2B Register Address: 0x151							
B7	B6	B5	B4	B3	B2	B1	B0
UNLOCK[7]	UNLOCK[6]	UNLOCK[5]	UNLOCK[4]	UNLOCK[3]	UNLOCK[2]	UNLOCK[1]	UNLOCK[0]
0	0	0	0	0	0	0	0
RW	RW	RW	RW	RW	RW	RW	RW
UNLOCK[7:0]	Second of two confirmation commands required before OTP programming. Must be written in sequence from OTP_PROG_UNLOCK2A to OTP_PROG_UNLOCK2D (OTP_PROG_UNLOCK2A > OTP_PROG_UNLOCK2B > OTP_PROG_UNLOCK2C > OTP_PROG_UNLOCK2D). Always returns 0x00 when read. Once the correct sequence is entered and the OTP is unlocked, the next write clears the lock condition. The write following the final unlock command must be to OTP_PROG_CTRL[PROG_GO] to program the OTP.						

**8.6.1.268 Register: OTP\_PROG\_UNLOCK2C**

OTP_PROG_UNLOCK2C Register Address: 0x152							
B7	B6	B5	B4	B3	B2	B1	B0
UNLOCK[7]	UNLOCK[6]	UNLOCK[5]	UNLOCK[4]	UNLOCK[3]	UNLOCK[2]	UNLOCK[1]	UNLOCK[0]
0	0	0	0	0	0	0	0
RW	RW	RW	RW	RW	RW	RW	RW
UNLOCK[7:0] Second of two confirmation commands required before OTP programming. Must be written in sequence from OTP_PROG_UNLOCK2A to OTP_PROG_UNLOCK2D (OTP_PROG_UNLOCK2A > OTP_PROG_UNLOCK2B > OTP_PROG_UNLOCK2C > OTP_PROG_UNLOCK2D). Always returns 0x00 when read. Once the correct sequence is entered and the OTP is unlocked, the next write clears the lock condition. The write following the final unlock command must be to OTP_PROG_CTRL[PROG_GO] to program the OTP.							

**8.6.1.269 Register: OTP\_PROG\_UNLOCK2D**

OTP_PROG_UNLOCK2D Register Address: 0x153							
B7	B6	B5	B4	B3	B2	B1	B0
UNLOCK[7]	UNLOCK[6]	UNLOCK[5]	UNLOCK[4]	UNLOCK[3]	UNLOCK[2]	UNLOCK[1]	UNLOCK[0]
0	0	0	0	0	0	0	0
RW	RW	RW	RW	RW	RW	RW	RW
UNLOCK[7:0] Second of two confirmation commands required before OTP programming. Must be written in sequence from OTP_PROG_UNLOCK2A to OTP_PROG_UNLOCK2D (OTP_PROG_UNLOCK2A > OTP_PROG_UNLOCK2B > OTP_PROG_UNLOCK2C > OTP_PROG_UNLOCK2D). Always returns 0x00 when read. Once the correct sequence is entered and the OTP is unlocked, the next write clears the lock condition. The write following the final unlock command must be to OTP_PROG_CTRL[PROG_GO] to program the OTP.							

**8.6.1.270 Register: SPI\_CFG**

SPI_CFG Register Address: 0x154							
B7	B6	B5	B4	B3	B2	B1	B0
RSVD	CPOL	CPHA	SS_STAT	SPI_EN	NUMBITS[2]	NUMBITS[1]	NUMBITS[0]
0	0	0	1	0	0	0	0
R	RW	RW	RW	RW	RW	RW	RW
RSVD	Reserved						
CPOL	Sets the SCLK polarity 0: Idles low and clocks high 1: Idles high and clocks low						
CPHA	Sets the edge of SCLK where data is sampled on MISO 0: First clock transition 1: Second clock transition						
SS_STAT	Programs the state of SS 0: Output low 1: Output high						
SPI_EN	Enables the SPI master function. The SPI master function has priority over normal GPIO function for GPIOs 3-6. Any configuration bits for these GPIOs is ignored. 0: Disabled 1: Enabled						
NUMBITS[2:0]	SPI Transaction length. Set number of SPI bits to read/write 000: 8 bits 001:111 Corresponds to 1 to 7 bits						

**8.6.1.271 Register: SPI\_TX**

SPI_TX Register Address: 0x155							
B7	B6	B5	B4	B3	B2	B1	B0
DATA[7]	DATA[6]	DATA[5]	DATA[4]	DATA[3]	DATA[2]	DATA[1]	DATA[0]
0	0	0	0	0	0	0	0
RW	RW	RW	RW	RW	RW	RW	RW
DATA[7:0] Data to be used for write during the SPI transaction. The bits programmed using SPI_CFG[NUMBITS] are clocked out of MOSI, starting from the lsb.							

### 8.6.1.272 Register: SPI\_EXE

SPI_EXE Register Address: 0x156							
B7	B6	B5	B4	B3	B2	B1	B0
RSVD[6]	RSVD[5]	RSVD[4]	RSVD[3]	RSVD[2]	RSVD[1]	RSVD[0]	SPI_GO
0	0	0	0	0	0	0	0
R	R	R	R	R	R	R	RW
RSVD[6:0]		Reserved					
SPI_GO		Executes the SPI transaction. See the "SPI Master" section for more details. 0: Idle 1: Execute command Always reads '0'					

### 8.6.1.273 Register: PARTID

PARTID Register Address: 0x200							
B7	B6	B5	B4	B3	B2	B1	B0
REV[7]	REV[6]	REV[5]	REV[4]	REV[3]	REV[2]	REV[1]	REV[0]
0	0	0	0	0	0	0	0
R	R	R	R	R	R	R	R
REV[7:0]		Device ID 0x01: First Revision 0x00: Reserved 0x02 - 0xFF: Reserved					

### 8.6.1.274 Register: SYS\_FAULT1

SYS_FAULT1 Register Address: 0x201							
B7	B6	B5	B4	B3	B2	B1	B0
RSVD	TWARN	Reserved	CTS	TSD	AVDD_REFUV_D RST	AVAO_REF_OV	DRST
0	0	0	0	0	0	0	1
R	R	R	R	R	R	R	R
RSVD		Reserved					
TWARN		Indicates the die temperature exceeds 105C. This is informational only, no action is taken. 0: No fault 1: Fault					
Reserved		Reserved					
CTS		Indicates a short communication timeout occurred 0: No fault 1: Fault					
TSD		Indicates the the device shutdown due to the die temperature exceeding TSD (Thermal shutdown threshold). 0: No fault 1: Fault					
AVDD_REFUV_D RST		Indicate the last digital reset caused by AVDD_REF under-voltage. 0: No fault 1: Fault					
AVAO_REF_OV		Indicates an over-voltage fault on the internal AVAO_REF rail. 0: No fault 1: Fault					
DRST		This bit indicate a digital reset 0: No fault 1: Fault					



**8.6.1.275 Register: SYS\_FAULT2**

SYS_FAULT2 Register Address: 0x202							
B7	B6	B5	B4	B3	B2	B1	B0
SHTDWN_REC	CVSS_OPEN	DVSS_OPEN	AVDD_OSC	TSREF_OSC	REF1_OSC	FACT_CRC	CUST_CRC
0	0	0	0	0	0	0	0
R	R	R	R	R	R	R	R
SHTDWN_REC	Indicates that the device was shut down using a SHUTDOWN tone or SHUTDOWN pulse on the WAKE input. 0: No fault 1: Fault						
CVSS_OPEN	Indicates an open condition for the CVSS pin. 0: No fault 1: Fault						
DVSS_OPEN	Indicates an open condition for the DVSS pin. 0: No fault 1: Fault						
AVDD_OSC	Indicates that the AVDD output is oscillating outside of acceptable limits. Reset this fault after Power up and any time AVDD is enabled. 0: No fault 1: Fault						
TSREF_OSC	Indicates that the TSREF output is oscillating outside of acceptable limits. Reset this fault after Power up and any time the TSREF is enabled. 0: No fault 1: Fault						
REF1_OSC	Indicates that the REF1 reference is oscillating outside of acceptable limits. 0: No fault 1: Fault						
FACT_CRC	Indicates a CRC error has occurred in the factory register space. 0: No fault 1: Fault						
CUST_CRC	Indicates a CRC error has occurred in the customer register space. 0: No fault 1: Fault						

**8.6.1.276 Register: SYS\_FAULT3**

SYS_FAULT3 Register Address: 0x203							
B7	B6	B5	B4	B3	B2	B1	B0
RSVD	AUX_FILTER	LP_FILTER	VIOUV	CB_VDONE	LFO	SEC_DETECT	DED_DETECT
0	0	0	0	0	0	0	0
R	R	R	R	R	R	R	R
RSVD	Reserved						
AUX_FILTER	Indicates a fault occurred in the filter diagnostic for the AUX ADC. 0: No fault 1: Fault						
LP_FILTER	Indicates a fault occurred in the low pass filter diagnostic. 0: No fault 1: Fault						
VIOUV	Indicates an under-voltage fault on the VIO. 0: No fault 1: Fault						
CB_VDONE	Indicates a fault occurred in the CB VDONE comparator (OVUV BIST must be enabled) 0: No fault 1: Fault						
LFO	Indicates that the LFO frequency is outside acceptable limits (fLFO_CHECK) 0: No fault 1: Fault						
SEC_DETECT	Indicates that a SEC error has occurred during the OTP load. (Unknown during Encoding) 0: No Fault 1: Fault						
DED_DETECT	Indicates that a DED fault has occurred during the OTP load. (Unknown during Encoding) 0: No Fault 1: Fault						

### 8.6.1.277 Register: DEV\_STAT

DEV_STAT Register Address: 0x204							
B7	B6	B5	B4	B3	B2	B1	B0
CRC_DONE	CB_DONE	CB_PAUSE	CB_RUN	AUX_STAT	CELL_STAT	DRDY_AUX	DRDY_CELL
0	0	0	0	0	0	0	0
R	R	R	R	R	R	R	R
CRC_DONE	Indicates the status of the CRC state machine. CRC_DONE is set when the CRC is calculated and compared to the CUST_CRC* registers. CRC_DONE gets updated every 800us. User must read it with this gap to ensure the correct value is seen. 0: Not complete 1: Complete (Clear on read)						
CB_DONE	Cell balancing complete status 0: Running or not started 1: All cell balancing complete (timers expired or VCBDONE comparators tripped)						
CB_PAUSE	Shows paused status of cell balancing. Cell balancing may pause during some safety checks 0: Running or not enabled 1: Paused						
CB_RUN	Shows the status of cell balancing cycle. Only valid after CONTROL2[BAL_GO] is set. Does not indicate the manual cell balance switch mode. 0: Complete or not started 1: Active on at least 1 cell (see CB_DONE register for individual cell status)						
AUX_STAT	Shows current status of Auxiliary ADC 0: Conversion not running 1: Conversion running						
CELL_STAT	Shows current status of Cell ADCs 0: Conversions not running 1: Conversions running						
DRDY_AUX	All of the AUX conversions are complete and the data is available to read. During continuous conversions, DRDY_AUX only indicates when the first round-robin conversions are complete. 0: No data available 1: Data is available (cleared with CONTROL2[AUX_ADC_GO]=1)						
DRDY_CELL	The CELL conversions are complete and the data is available to read. During continuous conversions, DRDY_CELL only indicates when the first conversion is complete. 0: No data available 1: Data is available (cleared with CONTROL2[CELL_ADC_GO]=1)						

### 8.6.1.278 Register: LOOP\_STAT

LOOP_STAT Register Address: 0x205							
B7	B6	B5	B4	B3	B2	B1	B0
RSVD[3]	RSVD[2]	RSVD[1]	RSVD[0]	OTUT_BIST_DO NE	OVUV_BIST_DO NE	OTUT_LOOP_DO NE	OVUV_LOOP_D ONE
0	0	0	0	0	0	0	0
R	R	R	R	R	R	R	R
RSVD[3:0]	Reserved						
OTUT_BIST_DO NE	Indicates when the OTUT BIST completes. 0: Running or not enabled 1: Completed (Cleared on read)						
OVUV_BIST_DO NE	Indicates when the OVUV BIST completes. 0: Running or not enabled 1: Completed (Cleared on read)						
OTUT_LOOP_DO NE	Indicates when the OTUT round robin completes a cycle. 0: Running or not enabled 1: Cycle completed (Cleared on read)						
OVUV_LOOP_D ONE	Indicates when the OVUV round robin completes a cycle. 0: Running or not enabled 1: Cycle completed (Cleared on read)						

**8.6.1.279 Register: FAULT\_SUMMARY**

FAULT_SUMMARY Register Address: 0x206							
B7	B6	B5	B4	B3	B2	B1	B0
RSVD[1]	RSVD[0]	OTP_FAULT	SYS_FAULT	COMM_FAULT	GPIO_OTUT	CELL_OVUV	GPIO_FAULT
0	0	0	0	0	0	0	0
R	R	R	R	R	R	R	R
RSVD[1:0]		Reserved					
OTP_FAULT		Indicates an unmasked fault in the OTP_FAULT register. 0: No Fault or masked fault 1: Unmasked fault					
SYS_FAULT		Indicates an unmasked fault for the RAIL_FAULT, SYS_FAULT1, SYS_FAULT2, and SYS_FAULT3 registers. 0: No Fault or masked fault 1: Unmasked fault					
COMM_FAULT		Indicates an unmasked fault in the TONE_FAULT, COMM_UART_FAULT, COMM_UART_RC_FAULT, COMM_UART_RR_FAULT, COMM_UART_TR_FAULT, COMM_COMH_FAULT, COMM_COMH_RC_FAULT, COMM_COMH_RR_FAULT, COMM_COMH_TR_FAULT, COMM_COML_FAULT, COMM_COML_RC_FAULT, COMM_COML_RR_FAULT, or COMM_COML_TR_FAULT registers. 0: No Fault or masked fault 1: Unmasked fault					
GPIO_OTUT		Indicates an unmasked fault in the OT_FAULT, UT_FAULT, or OTUT_BIST_FAULT registers 0: No Fault or masked fault 1: Unmasked fault					
CELL_OVUV		Indicates an unmasked fault in the OV_FAULT, UV_FAULT, or OVUV_BIST_FAULT registers 0: No Fault or masked fault 1: Unmasked fault					
GPIO_FAULT		Indicates an unmasked fault in the GPIO_FAULT register 0: No Fault or masked fault 1: Unmasked fault					

**8.6.1.280 Register: VCELL1\_HF**

VCELL1_HF Register Address: 0x207							
B7	B6	B5	B4	B3	B2	B1	B0
RESULT[7]	RESULT[6]	RESULT[5]	RESULT[4]	RESULT[3]	RESULT[2]	RESULT[1]	RESULT[0]
1	0	0	0	0	0	0	0
R	R	R	R	R	R	R	R
RESULT[7:0]		Cell 1 Voltage High Byte 2s complement (Low Pass Filtered)					

**8.6.1.281 Register: VCELL1\_LF**

VCELL1_LF Register Address: 0x208							
B7	B6	B5	B4	B3	B2	B1	B0
RESULT[7]	RESULT[6]	RESULT[5]	RESULT[4]	RESULT[3]	RESULT[2]	RESULT[1]	RESULT[0]
0	0	0	0	0	0	0	0
R	R	R	R	R	R	R	R
RESULT[7:0]		Cell 1 Voltage Low Byte 2s complement (Low Pass Filtered)					

**8.6.1.282 Register: VCELL2\_HF**

VCELL2_HF Register Address: 0x209							
B7	B6	B5	B4	B3	B2	B1	B0
RESULT[7]	RESULT[6]	RESULT[5]	RESULT[4]	RESULT[3]	RESULT[2]	RESULT[1]	RESULT[0]
1	0	0	0	0	0	0	0
R	R	R	R	R	R	R	R
RESULT[7:0]		Cell 2 Voltage High Byte 2s complement (Low Pass Filtered)					

**8.6.1.283 Register: VCELL2\_LF**

VCELL2_LF Register Address: 0x20A							
B7	B6	B5	B4	B3	B2	B1	B0
RESULT[7]	RESULT[6]	RESULT[5]	RESULT[4]	RESULT[3]	RESULT[2]	RESULT[1]	RESULT[0]
0	0	0	0	0	0	0	0
R	R	R	R	R	R	R	R

RESULT[7:0] Cell 2 Voltage Low Byte 2s complement (Low Pass Filtered)

**8.6.1.284 Register: VCELL3\_HF**

VCELL3_HF Register Address: 0x20B							
B7	B6	B5	B4	B3	B2	B1	B0
RESULT[7]	RESULT[6]	RESULT[5]	RESULT[4]	RESULT[3]	RESULT[2]	RESULT[1]	RESULT[0]
1	0	0	0	0	0	0	0
R	R	R	R	R	R	R	R

RESULT[7:0] Cell 3 Voltage High Byte 2s complement (Low Pass Filtered)

**8.6.1.285 Register: VCELL3\_LF**

VCELL3_LF Register Address: 0x20C							
B7	B6	B5	B4	B3	B2	B1	B0
RESULT[7]	RESULT[6]	RESULT[5]	RESULT[4]	RESULT[3]	RESULT[2]	RESULT[1]	RESULT[0]
0	0	0	0	0	0	0	0
R	R	R	R	R	R	R	R

RESULT[7:0] Cell 3 Voltage Low Byte 2s complement (Low Pass Filtered)

**8.6.1.286 Register: VCELL4\_HF**

VCELL4_HF Register Address: 0x20D							
B7	B6	B5	B4	B3	B2	B1	B0
RESULT[7]	RESULT[6]	RESULT[5]	RESULT[4]	RESULT[3]	RESULT[2]	RESULT[1]	RESULT[0]
1	0	0	0	0	0	0	0
R	R	R	R	R	R	R	R

RESULT[7:0] Cell 4 Voltage High Byte 2s complement (Low Pass Filtered)

**8.6.1.287 Register: VCELL4\_LF**

VCELL4_LF Register Address: 0x20E							
B7	B6	B5	B4	B3	B2	B1	B0
RESULT[7]	RESULT[6]	RESULT[5]	RESULT[4]	RESULT[3]	RESULT[2]	RESULT[1]	RESULT[0]
0	0	0	0	0	0	0	0
R	R	R	R	R	R	R	R

RESULT[7:0] Cell 4 Voltage Low Byte 2s complement (Low Pass Filtered)

**8.6.1.288 Register: VCELL5\_HF**

VCELL5_HF Register Address: 0x20F							
B7	B6	B5	B4	B3	B2	B1	B0
RESULT[7]	RESULT[6]	RESULT[5]	RESULT[4]	RESULT[3]	RESULT[2]	RESULT[1]	RESULT[0]
1	0	0	0	0	0	0	0
R	R	R	R	R	R	R	R

RESULT[7:0] Cell 5 Voltage High Byte 2s complement (Low Pass Filtered)

**8.6.1.289 Register: VCELL5\_LF**

VCELL5_LF Register Address: 0x210							
B7	B6	B5	B4	B3	B2	B1	B0
RESULT[7]	RESULT[6]	RESULT[5]	RESULT[4]	RESULT[3]	RESULT[2]	RESULT[1]	RESULT[0]
0	0	0	0	0	0	0	0
R	R	R	R	R	R	R	R
RESULT[7:0] Cell 5 Voltage Low Byte 2s complement (Low Pass Filtered)							

**8.6.1.290 Register: VCELL6\_HF**

VCELL6_HF Register Address: 0x211							
B7	B6	B5	B4	B3	B2	B1	B0
RESULT[7]	RESULT[6]	RESULT[5]	RESULT[4]	RESULT[3]	RESULT[2]	RESULT[1]	RESULT[0]
1	0	0	0	0	0	0	0
R	R	R	R	R	R	R	R
RESULT[7:0] Cell 6 Voltage High Byte 2s complement (Low Pass Filtered)							

**8.6.1.291 Register: VCELL6\_LF**

VCELL6_LF Register Address: 0x212							
B7	B6	B5	B4	B3	B2	B1	B0
RESULT[7]	RESULT[6]	RESULT[5]	RESULT[4]	RESULT[3]	RESULT[2]	RESULT[1]	RESULT[0]
0	0	0	0	0	0	0	0
R	R	R	R	R	R	R	R
RESULT[7:0] Cell 6 Voltage Low Byte 2s complement (Low Pass Filtered)							

**8.6.1.292 Register: CONV\_CNTH**

CONV_CNTH Register Address: 0x213							
B7	B6	B5	B4	B3	B2	B1	B0
RSVD[1]	RSVD[0]	COUNT[5]	COUNT[4]	COUNT[3]	COUNT[2]	COUNT[1]	COUNT[0]
0	0	0	0	0	0	0	0
R	R	R	R	R	R	R	R
RSVD[1:0] Reserved							
COUNT[5:0] High byte for continuous conversion counter. Updates with every completed conversion during continuous conversion mode by latching the internal counter value to CONV_CNTH and CONV_CNTL. Reset the internal counter when reading CONV_CNTH started or when CONTROL2[CELL_ADC_GO] = 1. Always reads 0x00 during single conversion mode.							

**8.6.1.293 Register: CONV\_CNTL**

CONV_CNTL Register Address: 0x214							
B7	B6	B5	B4	B3	B2	B1	B0
COUNT[7]	COUNT[6]	COUNT[5]	COUNT[4]	COUNT[3]	COUNT[2]	COUNT[1]	COUNT[0]
0	0	0	0	0	0	0	0
R	R	R	R	R	R	R	R
COUNT[7:0] Low byte for continuous conversion counter. Updates with every completed conversion during continuous conversion mode by latching the internal counter value to CONV_CNTH and CONV_CNTL. Reset the internal counter when reading CONV_CNTH started or when CONTROL2[CELL_ADC_GO] = 1. Always reads 0x01 during single conversion mode.							

**8.6.1.294 Register: VCELL1H**

VCELL1H Register Address: 0x215							
B7	B6	B5	B4	B3	B2	B1	B0
RESULT[7]	RESULT[6]	RESULT[5]	RESULT[4]	RESULT[3]	RESULT[2]	RESULT[1]	RESULT[0]
1	0	0	0	0	0	0	0
R	R	R	R	R	R	R	R
RESULT[7:0] Cell 1 Voltage High Byte 2s complement (Reference Corrected)							

**8.6.1.295 Register: VCELL1L**

VCELL1L Register Address: 0x216							
B7	B6	B5	B4	B3	B2	B1	B0
RESULT[7]	RESULT[6]	RESULT[5]	RESULT[4]	RESULT[3]	RESULT[2]	RESULT[1]	RESULT[0]
0	0	0	0	0	0	0	0
R	R	R	R	R	R	R	R
RESULT[7:0] Cell 1 Voltage Low Byte (Reference Corrected)							

**8.6.1.296 Register: VCELL2H**

VCELL2H Register Address: 0x217							
B7	B6	B5	B4	B3	B2	B1	B0
RESULT[7]	RESULT[6]	RESULT[5]	RESULT[4]	RESULT[3]	RESULT[2]	RESULT[1]	RESULT[0]
1	0	0	0	0	0	0	0
R	R	R	R	R	R	R	R
RESULT[7:0] Cell 2 Voltage High Byte 2s complement (Reference Corrected)							

**8.6.1.297 Register: VCELL2L**

VCELL2L Register Address: 0x218							
B7	B6	B5	B4	B3	B2	B1	B0
RESULT[7]	RESULT[6]	RESULT[5]	RESULT[4]	RESULT[3]	RESULT[2]	RESULT[1]	RESULT[0]
0	0	0	0	0	0	0	0
R	R	R	R	R	R	R	R
RESULT[7:0] Cell 2 Voltage Low Byte 2s complement (Reference Corrected)							

**8.6.1.298 Register: VCELL3H**

VCELL3H Register Address: 0x219							
B7	B6	B5	B4	B3	B2	B1	B0
RESULT[7]	RESULT[6]	RESULT[5]	RESULT[4]	RESULT[3]	RESULT[2]	RESULT[1]	RESULT[0]
1	0	0	0	0	0	0	0
R	R	R	R	R	R	R	R
RESULT[7:0] Cell 3 Voltage High Byte 2s complement (Reference Corrected)							

**8.6.1.299 Register: VCELL3L**

VCELL3L Register Address: 0x21A							
B7	B6	B5	B4	B3	B2	B1	B0
RESULT[7]	RESULT[6]	RESULT[5]	RESULT[4]	RESULT[3]	RESULT[2]	RESULT[1]	RESULT[0]
0	0	0	0	0	0	0	0
R	R	R	R	R	R	R	R
RESULT[7:0] Cell 3 Voltage Low Byte 2s complement (Reference Corrected)							

**8.6.1.300 Register: VCELL4H**

VCELL4H Register Address: 0x21B							
B7	B6	B5	B4	B3	B2	B1	B0
RESULT[7]	RESULT[6]	RESULT[5]	RESULT[4]	RESULT[3]	RESULT[2]	RESULT[1]	RESULT[0]
1	0	0	0	0	0	0	0
R	R	R	R	R	R	R	R
RESULT[7:0] Cell 4 Voltage High Byte 2s complement (Reference Corrected)							

**8.6.1.301 Register: VCELL4L**

VCELL4L Register Address: 0x21C							
B7	B6	B5	B4	B3	B2	B1	B0
RESULT[7]	RESULT[6]	RESULT[5]	RESULT[4]	RESULT[3]	RESULT[2]	RESULT[1]	RESULT[0]
0	0	0	0	0	0	0	0
R	R	R	R	R	R	R	R
RESULT[7:0] Cell 4 Voltage Low Byte 2s complement (Reference Corrected)							

**8.6.1.302 Register: VCELL5H**

VCELL5H Register Address: 0x21D							
B7	B6	B5	B4	B3	B2	B1	B0
RESULT[7]	RESULT[6]	RESULT[5]	RESULT[4]	RESULT[3]	RESULT[2]	RESULT[1]	RESULT[0]
1	0	0	0	0	0	0	0
R	R	R	R	R	R	R	R
RESULT[7:0] Cell 5 Voltage High Byte 2s complement (Reference Corrected)							

**8.6.1.303 Register: VCELL5L**

VCELL5L Register Address: 0x21E							
B7	B6	B5	B4	B3	B2	B1	B0
RESULT[7]	RESULT[6]	RESULT[5]	RESULT[4]	RESULT[3]	RESULT[2]	RESULT[1]	RESULT[0]
0	0	0	0	0	0	0	0
R	R	R	R	R	R	R	R
RESULT[7:0] Cell 5 Voltage Low Byte 2s complement (Reference Corrected)							

**8.6.1.304 Register: VCELL6H**

VCELL6H Register Address: 0x21F							
B7	B6	B5	B4	B3	B2	B1	B0
RESULT[7]	RESULT[6]	RESULT[5]	RESULT[4]	RESULT[3]	RESULT[2]	RESULT[1]	RESULT[0]
1	0	0	0	0	0	0	0
R	R	R	R	R	R	R	R
RESULT[7:0] Cell 6 Voltage High Byte 2s complement (Reference Corrected)							

**8.6.1.305 Register: VCELL6L**

VCELL6L Register Address: 0x220							
B7	B6	B5	B4	B3	B2	B1	B0
RESULT[7]	RESULT[6]	RESULT[5]	RESULT[4]	RESULT[3]	RESULT[2]	RESULT[1]	RESULT[0]
0	0	0	0	0	0	0	0
R	R	R	R	R	R	R	R
RESULT[7:0] Cell 6 Voltage Low Byte 2s complement (Reference Corrected)							

**8.6.1.306 Register: VCELL\_FACTCORRH**

VCELL_FACTCORRH Register Address: 0x221							
B7	B6	B5	B4	B3	B2	B1	B0
RESULT[7]	RESULT[6]	RESULT[5]	RESULT[4]	RESULT[3]	RESULT[2]	RESULT[1]	RESULT[0]
1	0	0	0	0	0	0	0
R	R	R	R	R	R	R	R
RESULT[7:0] Selected cell voltage high byte in 2s complement format. This result does NOT have the user correction factors applied. Cell is selected using the DIAG_CTRL2[AUX_CELL_SEL] bits.							

**8.6.1.307 Register: VCELL\_FACTCORRL**

VCELL_FACTCORRL Register Address: 0x222							
B7	B6	B5	B4	B3	B2	B1	B0
RESULT[7]	RESULT[6]	RESULT[5]	RESULT[4]	RESULT[3]	RESULT[2]	RESULT[1]	RESULT[0]
0	0	0	0	0	0	0	0
R	R	R	R	R	R	R	R

RESULT[7:0] Selected cell voltage low byte in 2s complement format. This result does NOT have the user correction factors applied. Cell is selected using the DIAG\_CTRL2[AUX\_CELL\_SEL] bits.

**8.6.1.308 Register: AUX\_CELLH**

AUX_CELLH Register Address: 0x223							
B7	B6	B5	B4	B3	B2	B1	B0
RESULT[7]	RESULT[6]	RESULT[5]	RESULT[4]	RESULT[3]	RESULT[2]	RESULT[1]	RESULT[0]
1	0	0	0	0	0	0	0
R	R	R	R	R	R	R	R

RESULT[7:0] AUX Cell Measurement Voltage High Byte

**8.6.1.309 Register: AUX\_CELLL**

AUX_CELLL Register Address: 0x224							
B7	B6	B5	B4	B3	B2	B1	B0
RESULT[7]	RESULT[6]	RESULT[5]	RESULT[4]	RESULT[3]	RESULT[2]	RESULT[1]	RESULT[0]
0	0	0	0	0	0	0	0
R	R	R	R	R	R	R	R

RESULT[7:0] AUX Cell Measurement Voltage Low Byte

**8.6.1.310 Register: AUX\_BATH**

AUX_BATH Register Address: 0x225							
B7	B6	B5	B4	B3	B2	B1	B0
RESULT[7]	RESULT[6]	RESULT[5]	RESULT[4]	RESULT[3]	RESULT[2]	RESULT[1]	RESULT[0]
1	0	0	0	0	0	0	0
R	R	R	R	R	R	R	R

RESULT[7:0] Cell Stack Voltage High Byte (Reference Corrected)

**8.6.1.311 Register: AUX\_BATL**

AUX_BATL Register Address: 0x226							
B7	B6	B5	B4	B3	B2	B1	B0
RESULT[7]	RESULT[6]	RESULT[5]	RESULT[4]	RESULT[3]	RESULT[2]	RESULT[1]	RESULT[0]
0	0	0	0	0	0	0	0
R	R	R	R	R	R	R	R

RESULT[7:0] Cell Stack Voltage Low Byte (Reference Corrected)

**8.6.1.312 Register: AUX\_REF2H**

AUX_REF2H Register Address: 0x227							
B7	B6	B5	B4	B3	B2	B1	B0
RESULT[7]	RESULT[6]	RESULT[5]	RESULT[4]	RESULT[3]	RESULT[2]	RESULT[1]	RESULT[0]
1	0	0	0	0	0	0	0
R	R	R	R	R	R	R	R

RESULT[7:0] Bandgap 1 Voltage Output High Byte



**8.6.1.313 Register: AUX\_REF2L**

AUX_REF2L Register Address: 0x228							
B7	B6	B5	B4	B3	B2	B1	B0
RESULT[7]	RESULT[6]	RESULT[5]	RESULT[4]	RESULT[3]	RESULT[2]	RESULT[1]	RESULT[0]
0	0	0	0	0	0	0	0
R	R	R	R	R	R	R	R
RESULT[7:0] Bandgap 1 Voltage Output Low Byte							

**8.6.1.314 Register: AUX\_ZEROH**

AUX_ZEROH Register Address: 0x229							
B7	B6	B5	B4	B3	B2	B1	B0
RESULT[7]	RESULT[6]	RESULT[5]	RESULT[4]	RESULT[3]	RESULT[2]	RESULT[1]	RESULT[0]
1	0	0	0	0	0	0	0
R	R	R	R	R	R	R	R
RESULT[7:0] 0V Reference Voltage High Byte							

**8.6.1.315 Register: AUX\_ZEROL**

AUX_ZEROL Register Address: 0x22A							
B7	B6	B5	B4	B3	B2	B1	B0
RESULT[7]	RESULT[6]	RESULT[5]	RESULT[4]	RESULT[3]	RESULT[2]	RESULT[1]	RESULT[0]
0	0	0	0	0	0	0	0
R	R	R	R	R	R	R	R
RESULT[7:0] 0V Reference Voltage Low Byte							

**8.6.1.316 Register: AUX\_AVDDH**

AUX_AVDDH Register Address: 0x22B							
B7	B6	B5	B4	B3	B2	B1	B0
RESULT[7]	RESULT[6]	RESULT[5]	RESULT[4]	RESULT[3]	RESULT[2]	RESULT[1]	RESULT[0]
1	0	0	0	0	0	0	0
R	R	R	R	R	R	R	R
RESULT[7:0] AVDD LDO Voltage Output High Byte							

**8.6.1.317 Register: AUX\_AVDDL**

AUX_AVDDL Register Address: 0x22C							
B7	B6	B5	B4	B3	B2	B1	B0
RESULT[7]	RESULT[6]	RESULT[5]	RESULT[4]	RESULT[3]	RESULT[2]	RESULT[1]	RESULT[0]
0	0	0	0	0	0	0	0
R	R	R	R	R	R	R	R
RESULT[7:0] AVDD LDO Voltage Output Low Byte							

**8.6.1.318 Register: AUX\_GPIO1H**

AUX_GPIO1H Register Address: 0x22D							
B7	B6	B5	B4	B3	B2	B1	B0
RESULT[7]	RESULT[6]	RESULT[5]	RESULT[4]	RESULT[3]	RESULT[2]	RESULT[1]	RESULT[0]
1	0	0	0	0	0	0	0
R	R	R	R	R	R	R	R
RESULT[7:0] GPIO Input 1 High Byte (Reference Corrected) Ratiometric result when TS selected Voltage result when AUX is selected							

**8.6.1.319 Register: AUX\_GPIO1L**

AUX_GPIO1L Register Address: 0x22E							
B7	B6	B5	B4	B3	B2	B1	B0
RESULT[7]	RESULT[6]	RESULT[5]	RESULT[4]	RESULT[3]	RESULT[2]	RESULT[1]	RESULT[0]
0	0	0	0	0	0	0	0
R	R	R	R	R	R	R	R
RESULT[7:0] GPIO Input 1 Low Byte (Reference Corrected) Ratiometric result when TS selected Voltage result when AUX is selected							

**8.6.1.320 Register: AUX\_GPIO2H**

AUX_GPIO2H Register Address: 0x22F							
B7	B6	B5	B4	B3	B2	B1	B0
RESULT[7]	RESULT[6]	RESULT[5]	RESULT[4]	RESULT[3]	RESULT[2]	RESULT[1]	RESULT[0]
1	0	0	0	0	0	0	0
R	R	R	R	R	R	R	R
RESULT[7:0] GPIO Input 2 High Byte (Reference Corrected) Ratiometric result when TS selected Voltage result when AUX is selected							

**8.6.1.321 Register: AUX\_GPIO2L**

AUX_GPIO2L Register Address: 0x230							
B7	B6	B5	B4	B3	B2	B1	B0
RESULT[7]	RESULT[6]	RESULT[5]	RESULT[4]	RESULT[3]	RESULT[2]	RESULT[1]	RESULT[0]
0	0	0	0	0	0	0	0
R	R	R	R	R	R	R	R
RESULT[7:0] GPIO Input 2 Low Byte (Reference Corrected) Ratiometric result when TS selected Voltage result when AUX is selected							

**8.6.1.322 Register: AUX\_GPIO3H**

AUX_GPIO3H Register Address: 0x231							
B7	B6	B5	B4	B3	B2	B1	B0
RESULT[7]	RESULT[6]	RESULT[5]	RESULT[4]	RESULT[3]	RESULT[2]	RESULT[1]	RESULT[0]
1	0	0	0	0	0	0	0
R	R	R	R	R	R	R	R
RESULT[7:0] GPIO Input 3 High Byte (Reference Corrected) Ratiometric result when TS selected Voltage result when AUX is selected							

**8.6.1.323 Register: AUX\_GPIO3L**

AUX_GPIO3L Register Address: 0x232							
B7	B6	B5	B4	B3	B2	B1	B0
RESULT[7]	RESULT[6]	RESULT[5]	RESULT[4]	RESULT[3]	RESULT[2]	RESULT[1]	RESULT[0]
0	0	0	0	0	0	0	0
R	R	R	R	R	R	R	R
RESULT[7:0] GPIO Input 3 Low Byte (Reference Corrected) Ratiometric result when TS selected Voltage result when AUX is selected							

**8.6.1.324 Register: AUX\_GPIO4H**

AUX_GPIO4H Register Address: 0x233							
B7	B6	B5	B4	B3	B2	B1	B0
RESULT[7]	RESULT[6]	RESULT[5]	RESULT[4]	RESULT[3]	RESULT[2]	RESULT[1]	RESULT[0]
1	0	0	0	0	0	0	0
R	R	R	R	R	R	R	R
RESULT[7:0] GPIO Input 4 High Byte (Reference Corrected) Ratiometric result when TS selected Voltage result when AUX is selected							

**8.6.1.325 Register: AUX\_GPIO4L**

AUX_GPIO4L Register Address: 0x234							
B7	B6	B5	B4	B3	B2	B1	B0
RESULT[7]	RESULT[6]	RESULT[5]	RESULT[4]	RESULT[3]	RESULT[2]	RESULT[1]	RESULT[0]
0	0	0	0	0	0	0	0
R	R	R	R	R	R	R	R
RESULT[7:0] GPIO Input 4 Low Byte (Reference Corrected) Ratiometric result when TS selected Voltage result when AUX is selected							

**8.6.1.326 Register: AUX\_GPIO5H**

AUX_GPIO5H Register Address: 0x235							
B7	B6	B5	B4	B3	B2	B1	B0
RESULT[7]	RESULT[6]	RESULT[5]	RESULT[4]	RESULT[3]	RESULT[2]	RESULT[1]	RESULT[0]
1	0	0	0	0	0	0	0
R	R	R	R	R	R	R	R
RESULT[7:0] GPIO Input 5 High Byte (Reference Corrected) Ratiometric result when TS selected Voltage result when AUX is selected							

**8.6.1.327 Register: AUX\_GPIO5L**

AUX_GPIO5L Register Address: 0x236							
B7	B6	B5	B4	B3	B2	B1	B0
RESULT[7]	RESULT[6]	RESULT[5]	RESULT[4]	RESULT[3]	RESULT[2]	RESULT[1]	RESULT[0]
0	0	0	0	0	0	0	0
R	R	R	R	R	R	R	R
RESULT[7:0] GPIO Input 5 Low Byte (Reference Corrected) Ratiometric result when TS selected Voltage result when AUX is selected							

**8.6.1.328 Register: AUX\_GPIO6H**

AUX_GPIO6H Register Address: 0x237							
B7	B6	B5	B4	B3	B2	B1	B0
RESULT[7]	RESULT[6]	RESULT[5]	RESULT[4]	RESULT[3]	RESULT[2]	RESULT[1]	RESULT[0]
1	0	0	0	0	0	0	0
R	R	R	R	R	R	R	R
RESULT[7:0] GPIO Input 6 High Byte (Reference Corrected) Ratiometric result when TS selected Voltage result when AUX is selected							

**8.6.1.329 Register: AUX\_GPIO6L**

AUX_GPIO6L Register Address: 0x238							
B7	B6	B5	B4	B3	B2	B1	B0
RESULT[7]	RESULT[6]	RESULT[5]	RESULT[4]	RESULT[3]	RESULT[2]	RESULT[1]	RESULT[0]
0	0	0	0	0	0	0	0
R	R	R	R	R	R	R	R
RESULT[7:0] GPIO Input 6 Low Byte (Reference Corrected) Ratiometric result when TS selected Reference correct voltage result when AUX is selected							

**8.6.1.330 Register: AUX\_FACTCORRH**

AUX_FACTCORRH Register Address: 0x239							
B7	B6	B5	B4	B3	B2	B1	B0
RESULT[7]	RESULT[6]	RESULT[5]	RESULT[4]	RESULT[3]	RESULT[2]	RESULT[1]	RESULT[0]
1	0	0	0	0	0	0	0
R	R	R	R	R	R	R	R
RESULT[7:0] Selected GPIO voltage high byte in 2s complement format. This result does NOT have the user correction factors applied. GPIO is selected using the DIAG_CTRL2[AUX_GPIO_SEL] bits.							

**8.6.1.331 Register: AUX\_FACTCORRL**

AUX_FACTCORRL Register Address: 0x23A							
B7	B6	B5	B4	B3	B2	B1	B0
RESULT[7]	RESULT[6]	RESULT[5]	RESULT[4]	RESULT[3]	RESULT[2]	RESULT[1]	RESULT[0]
0	0	0	0	0	0	0	0
R	R	R	R	R	R	R	R
RESULT[7:0] Selected GPIO voltage low byte in 2s complement format. This result does NOT have the user correction factors applied. GPIO is selected using the DIAG_CTRL2[AUX_GPIO_SEL] bits.							

**8.6.1.332 Register: DIE\_TEMP**

DIE_TEMP Register Address: 0x23B							
B7	B6	B5	B4	B3	B2	B1	B0
RESULT[7]	RESULT[6]	RESULT[5]	RESULT[4]	RESULT[3]	RESULT[2]	RESULT[1]	RESULT[0]
1	0	0	0	0	0	0	0
R	R	R	R	R	R	R	R
RESULT[7:0] Die Junction Temperature. No digital correction done on DIE junction temperature measurement.							

**8.6.1.333 Register: DIE\_TEMPL**

DIE_TEMPL Register Address: 0x23C							
B7	B6	B5	B4	B3	B2	B1	B0
RESULT[7]	RESULT[6]	RESULT[5]	RESULT[4]	RESULT[3]	RESULT[2]	RESULT[1]	RESULT[0]
0	0	0	0	0	0	0	0
R	R	R	R	R	R	R	R
RESULT[7:0] Die Junction Temperature. No digital correction done on DIE junction temperature measurement.							

**8.6.1.334 Register: AUX\_REF3H**

AUX_REF3H Register Address: 0x23D							
B7	B6	B5	B4	B3	B2	B1	B0
RESULT[7]	RESULT[6]	RESULT[5]	RESULT[4]	RESULT[3]	RESULT[2]	RESULT[1]	RESULT[0]
1	0	0	0	0	0	0	0
R	R	R	R	R	R	R	R
RESULT[7:0] Bandgap 2 Voltage Output High Byte							

**8.6.1.335 Register: AUX\_REF3L**

AUX_REF3L Register Address: 0x23E							
B7	B6	B5	B4	B3	B2	B1	B0
RESULT[7]	RESULT[6]	RESULT[5]	RESULT[4]	RESULT[3]	RESULT[2]	RESULT[1]	RESULT[0]
0	0	0	0	0	0	0	0
R	R	R	R	R	R	R	R

RESULT[7:0] Bandgap 2 Voltage Output Low Byte

**8.6.1.336 Register: AUX\_OV\_DACH**

AUX_OV_DACH Register Address: 0x23F							
B7	B6	B5	B4	B3	B2	B1	B0
RESULT[7]	RESULT[6]	RESULT[5]	RESULT[4]	RESULT[3]	RESULT[2]	RESULT[1]	RESULT[0]
1	0	0	0	0	0	0	0
R	R	R	R	R	R	R	R

RESULT[7:0] OV Bandgap Voltage High Byte

**8.6.1.337 Register: AUX\_OV\_DACL**

AUX_OV_DACL Register Address: 0x240							
B7	B6	B5	B4	B3	B2	B1	B0
RESULT[7]	RESULT[6]	RESULT[5]	RESULT[4]	RESULT[3]	RESULT[2]	RESULT[1]	RESULT[0]
0	0	0	0	0	0	0	0
R	R	R	R	R	R	R	R

RESULT[7:0] OV Reference Voltage Low Byte

**8.6.1.338 Register: AUX\_UV\_DACH**

AUX_UV_DACH Register Address: 0x241							
B7	B6	B5	B4	B3	B2	B1	B0
RESULT[7]	RESULT[6]	RESULT[5]	RESULT[4]	RESULT[3]	RESULT[2]	RESULT[1]	RESULT[0]
1	0	0	0	0	0	0	0
R	R	R	R	R	R	R	R

RESULT[7:0] UV Bandgap Voltage High Byte

**8.6.1.339 Register: AUX\_UV\_DACL**

AUX_UV_DACL Register Address: 0x242							
B7	B6	B5	B4	B3	B2	B1	B0
RESULT[7]	RESULT[6]	RESULT[5]	RESULT[4]	RESULT[3]	RESULT[2]	RESULT[1]	RESULT[0]
0	0	0	0	0	0	0	0
R	R	R	R	R	R	R	R

RESULT[7:0] UV Reference Voltage Low Byte

**8.6.1.340 Register: AUX\_OT\_DACH**

AUX_OT_DACH Register Address: 0x243							
B7	B6	B5	B4	B3	B2	B1	B0
RESULT[7]	RESULT[6]	RESULT[5]	RESULT[4]	RESULT[3]	RESULT[2]	RESULT[1]	RESULT[0]
1	0	0	0	0	0	0	0
R	R	R	R	R	R	R	R

RESULT[7:0] OT Bandgap Voltage High Byte

### 8.6.1.341 Register: AUX\_OT\_DACL

AUX_OT_DACL Register Address: 0x244							
B7	B6	B5	B4	B3	B2	B1	B0
RESULT[7]	RESULT[6]	RESULT[5]	RESULT[4]	RESULT[3]	RESULT[2]	RESULT[1]	RESULT[0]
0	0	0	0	0	0	0	0
R	R	R	R	R	R	R	R
RESULT[7:0] OT Reference Voltage Low Byte							

### 8.6.1.342 Register: AUX\_UT\_DACH

AUX_UT_DACH Register Address: 0x245							
B7	B6	B5	B4	B3	B2	B1	B0
RESULT[7]	RESULT[6]	RESULT[5]	RESULT[4]	RESULT[3]	RESULT[2]	RESULT[1]	RESULT[0]
1	0	0	0	0	0	0	0
R	R	R	R	R	R	R	R
RESULT[7:0] UT Bandgap Voltage High Byte							

### 8.6.1.343 Register: AUX\_UT\_DACL

AUX_UT_DACL Register Address: 0x246							
B7	B6	B5	B4	B3	B2	B1	B0
RESULT[7]	RESULT[6]	RESULT[5]	RESULT[4]	RESULT[3]	RESULT[2]	RESULT[1]	RESULT[0]
0	0	0	0	0	0	0	0
R	R	R	R	R	R	R	R
RESULT[7:0] UT Reference Voltage Low Byte							

### 8.6.1.344 Register: AUX\_TWARN\_PTATH

AUX_TWARN_PTATH Register Address: 0x247							
B7	B6	B5	B4	B3	B2	B1	B0
RESULT[7]	RESULT[6]	RESULT[5]	RESULT[4]	RESULT[3]	RESULT[2]	RESULT[1]	RESULT[0]
1	0	0	0	0	0	0	0
R	R	R	R	R	R	R	R
RESULT[7:0] TWARN PTAT Current High Byte							

### 8.6.1.345 Register: AUX\_TWARN\_PTATL

AUX_TWARN_PTATL Register Address: 0x248							
B7	B6	B5	B4	B3	B2	B1	B0
RESULT[7]	RESULT[6]	RESULT[5]	RESULT[4]	RESULT[3]	RESULT[2]	RESULT[1]	RESULT[0]
0	0	0	0	0	0	0	0
R	R	R	R	R	R	R	R
RESULT[7:0] TWARN PTAT Current Low Byte							

### 8.6.1.346 Register: AUX\_DVDDH

AUX_DVDDH Register Address: 0x249							
B7	B6	B5	B4	B3	B2	B1	B0
RESULT[7]	RESULT[6]	RESULT[5]	RESULT[4]	RESULT[3]	RESULT[2]	RESULT[1]	RESULT[0]
1	0	0	0	0	0	0	0
R	R	R	R	R	R	R	R
RESULT[7:0] DVDD LDO Voltage Output High Byte							

**8.6.1.347 Register: AUX\_DVDDL**

AUX_DVDDL Register Address: 0x24A							
B7	B6	B5	B4	B3	B2	B1	B0
RESULT[7]	RESULT[6]	RESULT[5]	RESULT[4]	RESULT[3]	RESULT[2]	RESULT[1]	RESULT[0]
0	0	0	0	0	0	0	0
R	R	R	R	R	R	R	R
RESULT[7:0] DVDD LDO Voltage Output Low Byte							

**8.6.1.348 Register: AUX\_TSREFH**

AUX_TSREFH Register Address: 0x24B							
B7	B6	B5	B4	B3	B2	B1	B0
RESULT[7]	RESULT[6]	RESULT[5]	RESULT[4]	RESULT[3]	RESULT[2]	RESULT[1]	RESULT[0]
1	0	0	0	0	0	0	0
R	R	R	R	R	R	R	R
RESULT[7:0] TSREF Voltage Output High Byte							

**8.6.1.349 Register: AUX\_TSREFL**

AUX_TSREFL Register Address: 0x24C							
B7	B6	B5	B4	B3	B2	B1	B0
RESULT[7]	RESULT[6]	RESULT[5]	RESULT[4]	RESULT[3]	RESULT[2]	RESULT[1]	RESULT[0]
0	0	0	0	0	0	0	0
R	R	R	R	R	R	R	R
RESULT[7:0] TSREF Voltage Output Low Byte							

**8.6.1.350 Register: AUX\_CVDDH**

AUX_CVDDH Register Address: 0x24D							
B7	B6	B5	B4	B3	B2	B1	B0
RESULT[7]	RESULT[6]	RESULT[5]	RESULT[4]	RESULT[3]	RESULT[2]	RESULT[1]	RESULT[0]
1	0	0	0	0	0	0	0
R	R	R	R	R	R	R	R
RESULT[7:0] CVDD LDO Voltage Output High Byte							

**8.6.1.351 Register: AUX\_CVDDL**

AUX_CVDDL Register Address: 0x24E							
B7	B6	B5	B4	B3	B2	B1	B0
RESULT[7]	RESULT[6]	RESULT[5]	RESULT[4]	RESULT[3]	RESULT[2]	RESULT[1]	RESULT[0]
0	0	0	0	0	0	0	0
R	R	R	R	R	R	R	R
RESULT[7:0] CVDD LDO Voltage Output Low Byte							

**8.6.1.352 Register: AUX\_AVAO\_REFH**

AUX_AVAO_REFH Register Address: 0x24F							
B7	B6	B5	B4	B3	B2	B1	B0
RESULT[7]	RESULT[6]	RESULT[5]	RESULT[4]	RESULT[3]	RESULT[2]	RESULT[1]	RESULT[0]
1	0	0	0	0	0	0	0
R	R	R	R	R	R	R	R
RESULT[7:0] AVAO_REF Reference Voltage High Byte							

**8.6.1.353 Register: AUX\_AVAO\_REFL**

AUX_AVAO_REFL Register Address: 0x250							
B7	B6	B5	B4	B3	B2	B1	B0
RESULT[7]	RESULT[6]	RESULT[5]	RESULT[4]	RESULT[3]	RESULT[2]	RESULT[1]	RESULT[0]
0	0	0	0	0	0	0	0
R	R	R	R	R	R	R	R
RESULT[7:0] AVAO_REF Reference Voltage Low Byte							

**8.6.1.354 Register: SPI\_RX**

SPI_RX Register Address: 0x260							
B7	B6	B5	B4	B3	B2	B1	B0
DATA[7]	DATA[6]	DATA[5]	DATA[4]	DATA[3]	DATA[2]	DATA[1]	DATA[0]
0	0	0	0	0	0	0	0
R	R	R	R	R	R	R	R
DATA[7:0] Data returned from read during SPI transaction. Updated, starting with lsb, with the number of bits set by SPI_CFG[NUMBITS] clocked in from MISO.							

**8.6.1.355 Register: CB\_DONE**

CB_DONE Register Address: 0x261							
B7	B6	B5	B4	B3	B2	B1	B0
RSVD	ABORTFLT	CELL6	CELL5	CELL4	CELL3	CELL2	CELL1
0	0	0	0	0	0	0	0
R	R	R	R	R	R	R	R
RSVD Reserved							
ABORTFLT Indicates cell balancing aborted due to system fault 0: Not aborted or cell balancing not run 1: Aborted (Cleared when CONTROL[BAL_GO] = 1)							
CELL6 Indicates that the cell balancing cycle is complete for cell 6, either by CBDONE comparator tripping, or CB timer expired 0: Not completed or balancing cycle has not started 1: Completed (Cleared when CONTROL[BAL_GO] = 1)							
CELL5 Indicates that the cell balancing cycle is complete for cell 5, either by CBDONE comparator tripping, or CB timer expired 0: Not completed or balancing cycle has not started 1: Completed (Cleared when CONTROL[BAL_GO] = 1)							
CELL4 Indicates that the cell balancing cycle is complete for cell 4, either by CBDONE comparator tripping, or CB timer expired 0: Not completed or balancing cycle has not started 1: Completed (Cleared when CONTROL[BAL_GO] = 1)							
CELL3 Indicates that the cell balancing cycle is complete for cell 3, either by CBDONE comparator tripping, or CB timer expired 0: Not completed or balancing cycle has not started 1: Completed (Cleared when CONTROL[BAL_GO] = 1)							
CELL2 Indicates that the cell balancing cycle is complete for cell 2, either by CBDONE comparator tripping, or CB timer expired 0: Not completed or balancing cycle has not started 1: Completed (Cleared when CONTROL[BAL_GO] = 1)							
CELL1 Indicates that the cell balancing cycle is complete for cell 1, either by CBDONE comparator tripping, or CB timer expired 0: Not completed or balancing cycle has not started 1: Completed (Cleared when CONTROL[BAL_GO] = 1)							



**8.6.1.356 Register: GPIO\_STAT**

GPIO_STAT Register Address: 0x262							
B7	B6	B5	B4	B3	B2	B1	B0
RSVD[1]	RSVD[0]	GPIO6	GPIO5	GPIO4	GPIO3	GPIO2	GPIO1
0	0	0	0	0	0	0	0
R	R	R	R	R	R	R	R
RSVD[1:0]		Reserved					
GPIO6		Indicates GPIO6 status. Indicates status regardless of input/output configuration. 0: Low 1: High					
GPIO5		Indicates GPIO5 status. Indicates status regardless of input/output configuration. 0: Low 1: High					
GPIO4		Indicates GPIO4 status. Indicates status regardless of input/output configuration. 0: Low 1: High					
GPIO3		Indicates GPIO3 status. Indicates status regardless of input/output configuration. 0: Low 1: High					
GPIO2		Indicates GPIO2 status. Indicates status regardless of input/output configuration. 0: Low 1: High					
GPIO1		Indicates GPIO1 status. Indicates status regardless of input/output configuration. 0: Low 1: High					

**8.6.1.357 Register: CBVC\_COMP\_STAT**

CBVC_COMP_STAT Register Address: 0x263							
B7	B6	B5	B4	B3	B2	B1	B0
RSVD[1]	RSVD[0]	CELL6	CELL5	CELL4	CELL3	CELL2	CELL1
0	0	0	0	0	0	0	0
R	R	R	R	R	R	R	R
RSVD[1:0]		Reserved					
CELL6		Indicates the CBVC comparator status. Expect a 2.5ms delay after the CBVC comparator is on for this register to be updated. Only valid when CBVC_COMP_CTRL[CELL6] = 1. 0: $(CB6-CB5) / (VC6-VC5) < VCBVCFLT$ , or CBVC comparator is disabled for CELL6 1: $(CB6-CB5) / (VC6-VC5) > VCBVCFLT$					
CELL5		Indicates the CBVC comparator status. Expect a 2.5ms delay after the CBVC comparator is on for this register to be updated. Only valid when CBVC_COMP_CTRL[CELL5] = 1. 0: $(CB5-CB4) / (VC5-VC4) < VCBVCFLT$ , or CBVC comparator is disabled for CELL5 1: $(CB5-CB4) / (VC5-VC4) > VCBVCFLT$					
CELL4		Indicates the CBVC comparator status. Expect a 2.5ms delay after the CBVC comparator is on for this register to be updated. Only valid when CBVC_COMP_CTRL[CELL4] = 1. 0: $(CB4-CB3) / (VC4-VC3) < VCBVCFLT$ , or CBVC comparator is disabled for CELL4 1: $(CB4-CB3) / (VC4-VC3) > VCBVCFLT$					
CELL3		Indicates the CBVC comparator status. Expect a 2.5ms delay after the CBVC comparator is on for this register to be updated. Only valid when CBVC_COMP_CTRL[CELL3] = 1. 0: $(CB3-CB2) / (VC3-VC2) < VCBVCFLT$ , or CBVC comparator is disabled for CELL3 1: $(CB3-CB2) / (VC3-VC2) > VCBVCFLT$					
CELL2		Indicates the CBVC comparator status. Expect a 2.5ms delay after the CBVC comparator is on for this register to be updated. Only valid when CBVC_COMP_CTRL[CELL2] = 1. 0: $(CB2-CB1) / (VC2-VC1) < VCBVCFLT$ , or CBVC comparator is disabled for CELL2 1: $(CB2-CB1) / (VC2-VC1) > VCBVCFLT$					
CELL1		Indicates the CBVC comparator status. Expect a 2.5ms delay after the CBVC comparator is on for this register to be updated. Only valid when CBVC_COMP_CTRL[CELL1] = 1. 0: $(CB1-CB0) / (VC1-VC0) < VCBVCFLT$ , or CBVC comparator is disabled for CELL1 1: $(CB1-CB0) / (VC1-VC0) > VCBVCFLT$					

**8.6.1.358 Register: CBVC\_VCLOW\_STAT**

CBVC_VCLOW_STAT Register Address: 0x264							
B7	B6	B5	B4	B3	B2	B1	B0
RSVD[1]	RSVD[0]	CELL6	CELL5	CELL4	CELL3	CELL2	CELL1
0	0	0	0	0	0	0	0
R	R	R	R	R	R	R	R
RSVD[1:0]	Reserved						
CELL6	Indicates the VCLOW comparator status. If set, the result in CBVC_COMP_STAT cannot be trusted. Only valid when CBVC_COMP_CTRL[CELL6] = 1. 0: (VC6-VC5) is ok, or CBVC comparator is disabled for CELL6 1: (VC6-VC5) too low for valid CBVC_COMP operation						
CELL5	Indicates the VCLOW comparator status. If set, the result in CBVC_COMP_STAT cannot be trusted. Only valid when CBVC_COMP_CTRL[CELL5] = 1. 0: (VC5-VC4) is ok, or CBVC comparator is disabled for CELL5 1: (VC5-VC4) too low for valid CBVC_COMP operation						
CELL4	Indicates the VCLOW comparator status. If set, the result in CBVC_COMP_STAT cannot be trusted. Only valid when CBVC_COMP_CTRL[CELL4] = 1. 0: (VC4-VC3) is ok, or CBVC comparator is disabled for CELL4 1: (VC4-VC3) too low for valid CBVC_COMP operation						
CELL3	Indicates the VCLOW comparator status. If set, the result in CBVC_COMP_STAT cannot be trusted. Only valid when CBVC_COMP_CTRL[CELL3] = 1. 0: (VC3-VC2) is ok, or CBVC comparator is disabled for CELL3 1: (VC3-VC2) too low for valid CBVC_COMP operation						
CELL2	Indicates the VCLOW comparator status. If set, the result in CBVC_COMP_STAT cannot be trusted. Only valid when CBVC_COMP_CTRL[CELL2] = 1. 0: (VC2-VC1) is ok, or CBVC comparator is disabled for CELL2 1: (VC2-VC1) too low for valid CBVC_COMP operation						
CELL1	Indicates the VCLOW comparator status. If set, the result in CBVC_COMP_STAT cannot be trusted. Only valid when CBVC_COMP_CTRL[CELL1] = 1. 0: (VC1-VC0) is ok, or CBVC comparator is disabled for CELL1 1: (VC1-VC0) too low for valid CBVC_COMP operation						

**8.6.1.359 Register: COMM\_UART\_RC\_STAT3**

COMM_UART_RC_STAT3 Register Address: 0x265							
B7	B6	B5	B4	B3	B2	B1	B0
DISCARD[7]	DISCARD[6]	DISCARD[5]	DISCARD[4]	DISCARD[3]	DISCARD[2]	DISCARD[1]	DISCARD[0]
0	0	0	0	0	0	0	0
R	R	R	R	R	R	R	R
DISCARD[7:0]	Counter for discarded command frames received on the UART interface. The COMM_UART_*_STAT* registers are updated and the counters are reset when the COMM_UART_RC_STAT3 register is read to ensure all counter data refers to the same period of time. Note that this counter will not increment in case of IERR error.						

**8.6.1.360 Register: COMM\_COML\_RC\_STAT3**

COMM_COML_RC_STAT3 Register Address: 0x266							
B7	B6	B5	B4	B3	B2	B1	B0
DISCARD[7]	DISCARD[6]	DISCARD[5]	DISCARD[4]	DISCARD[3]	DISCARD[2]	DISCARD[1]	DISCARD[0]
0	0	0	0	0	0	0	0
R	R	R	R	R	R	R	R
DISCARD[7:0]	Counter for discarded command frames received on the COML interface. The COMM_COML_*_STAT* registers are updated and the counters are reset when the COMM_COML_RC_STAT3 register is read to ensure all counter data refers to the same period of time. Note that this counter will not increment in case of IERR error.						

**8.6.1.361 Register: COMM\_COMH\_RR\_STAT3**

COMM_COMH_RR_STAT3 Register Address: 0x267							
B7	B6	B5	B4	B3	B2	B1	B0
DISCARD[7]	DISCARD[6]	DISCARD[5]	DISCARD[4]	DISCARD[3]	DISCARD[2]	DISCARD[1]	DISCARD[0]
0	0	0	0	0	0	0	0
R	R	R	R	R	R	R	R
DISCARD[7:0] Counter for discarded response frames received on the COMH interface. The COMM_COMH_*_STAT* registers are updated and the counters are reset when the COMM_COMH_RR_STAT3 register is read to ensure all counter data refers to the same period of time. Note that this counter will not increment in case of IERR error.							

**8.6.1.362 Register: COMM\_COML\_RR\_STAT3**

COMM_COML_RR_STAT3 Register Address: 0x268							
B7	B6	B5	B4	B3	B2	B1	B0
DISCARD[7]	DISCARD[6]	DISCARD[5]	DISCARD[4]	DISCARD[3]	DISCARD[2]	DISCARD[1]	DISCARD[0]
0	0	0	0	0	0	0	0
R	R	R	R	R	R	R	R
DISCARD[7:0] Counter for discarded response frames received on the COML interface. The COMM_COML_*_STAT* registers are updated and the counters are reset when the COMM_COML_RC_STAT3 register is read to ensure all counter data refers to the same period of time. Note that this counter will not increment in case of IERR error.							

**8.6.1.363 Register: COMM\_COMH\_RC\_STAT3**

COMM_COMH_RC_STAT3 Register Address: 0x269							
B7	B6	B5	B4	B3	B2	B1	B0
DISCARD[7]	DISCARD[6]	DISCARD[5]	DISCARD[4]	DISCARD[3]	DISCARD[2]	DISCARD[1]	DISCARD[0]
0	0	0	0	0	0	0	0
R	R	R	R	R	R	R	R
DISCARD[7:0] Counter for discarded command frames received on the COMH interface. The COMM_COMH_*_STAT* registers are updated and the counters are reset when the COMM_COMH_RR_STAT3 register is read to ensure all counter data refers to the same period of time. Note that this counter will not increment in case of IERR error.							

**8.6.1.364 Register: COMM\_UART\_RR\_STAT3**

COMM_UART_RR_STAT3 Register Address: 0x26A							
B7	B6	B5	B4	B3	B2	B1	B0
DISCARD[7]	DISCARD[6]	DISCARD[5]	DISCARD[4]	DISCARD[3]	DISCARD[2]	DISCARD[1]	DISCARD[0]
0	0	0	0	0	0	0	0
R	R	R	R	R	R	R	R
DISCARD[7:0] Counter for discarded response frames received on the UART interface. The COMM_UART_*_STAT* registers are updated and the counters are reset when the COMM_UART_RC_STAT3 register is read to ensure all counter data refers to the same period of time. Note that this counter will not increment in case of IERR error.							

**8.6.1.365 Register: COMM\_UART\_RC\_STAT1**

COMM_UART_RC_STAT1 Register Address: 0x26B							
B7	B6	B5	B4	B3	B2	B1	B0
VALIDH[7]	VALIDH[6]	VALIDH[5]	VALIDH[4]	VALIDH[3]	VALIDH[2]	VALIDH[1]	VALIDH[0]
0	0	0	0	0	0	0	0
R	R	R	R	R	R	R	R
VALIDH[7:0] High byte of the valid command counter for received command frames from the UART interface. Counter saturates when COMM_UART_RC_STAT1[VALIDH] and COMM_UART_RC_STAT2[VALIDL] reach 0xFFFF. The COMM_UART_*_STAT* registers are updated and the counters are reset when the COMM_UART_RC_STAT3 register is read to ensure all counter data refers to the same period of time.							

### 8.6.1.366 Register: COMM\_UART\_RC\_STAT2

COMM_UART_RC_STAT2 Register Address: 0x26C							
B7	B6	B5	B4	B3	B2	B1	B0
VALIDL[7]	VALIDL[6]	VALIDL[5]	VALIDL[4]	VALIDL[3]	VALIDL[2]	VALIDL[1]	VALIDL[0]
0	0	0	0	0	0	0	0
R	R	R	R	R	R	R	R
VALIDL[7:0] High byte of the valid command counter for received command frames from the UART interface. Counter saturates when COMM_UART_RC_STAT1[VALIDH] and COMM_UART_RC_STAT2[VALIDL] reach 0xFFFF. The COMM_UART_*_STAT* registers are updated and the counters are reset when the COMM_UART_RC_STAT3 register is read to ensure all counter data refers to the same period of time.							

### 8.6.1.367 Register: COMM\_COML\_RC\_STAT1

COMM_COML_RC_STAT1 Register Address: 0x26D							
B7	B6	B5	B4	B3	B2	B1	B0
VALIDH[7]	VALIDH[6]	VALIDH[5]	VALIDH[4]	VALIDH[3]	VALIDH[2]	VALIDH[1]	VALIDH[0]
0	0	0	0	0	0	0	0
R	R	R	R	R	R	R	R
VALIDH[7:0] High byte of the valid command counter for received command frames from the COML interface. Counter saturates when COMM_COML_RC_STAT1[VALIDH] and COMM_COML_RC_STAT2[VALIDL] reach 0xFFFF. The COMM_COML_*_STAT* registers are updated and the counters are reset when the COMM_COML_RC_STAT3 register is read to ensure all counter data refers to the same period of time.							

### 8.6.1.368 Register: COMM\_COML\_RC\_STAT2

COMM_COML_RC_STAT2 Register Address: 0x26E							
B7	B6	B5	B4	B3	B2	B1	B0
VALIDL[7]	VALIDL[6]	VALIDL[5]	VALIDL[4]	VALIDL[3]	VALIDL[2]	VALIDL[1]	VALIDL[0]
0	0	0	0	0	0	0	0
R	R	R	R	R	R	R	R
VALIDL[7:0] High byte of the valid command counter for received command frames from the COML interface. Counter saturates when COMM_COML_RC_STAT1[VALIDH] and COMM_COML_RC_STAT2[VALIDL] reach 0xFFFF. The COMM_COML_*_STAT* registers are updated and the counters are reset when the COMM_COML_RC_STAT3 register is read to ensure all counter data refers to the same period of time.							

### 8.6.1.369 Register: COMM\_COMH\_RR\_STAT1

COMM_COMH_RR_STAT1 Register Address: 0x26F							
B7	B6	B5	B4	B3	B2	B1	B0
VALIDH[7]	VALIDH[6]	VALIDH[5]	VALIDH[4]	VALIDH[3]	VALIDH[2]	VALIDH[1]	VALIDH[0]
0	0	0	0	0	0	0	0
R	R	R	R	R	R	R	R
VALIDH[7:0] High byte of the valid command counter for received response frames from the COMH interface. Counter saturates when COMM_COMH_RC_STAT1[VALIDH] and COMM_COMH_RC_STAT1[VALIDL] reach 0xFFFF. The COMM_COMH_*_STAT* registers are updated and the counters are reset when the COMM_COMH_RR_STAT3 register is read to ensure all counter data refers to the same period of time.							

### 8.6.1.370 Register: COMM\_COMH\_RR\_STAT2

COMM_COMH_RR_STAT2 Register Address: 0x270							
B7	B6	B5	B4	B3	B2	B1	B0
VALIDL[7]	VALIDL[6]	VALIDL[5]	VALIDL[4]	VALIDL[3]	VALIDL[2]	VALIDL[1]	VALIDL[0]
0	0	0	0	0	0	0	0
R	R	R	R	R	R	R	R
VALIDL[7:0] High byte of the valid command counter for received response frames from the COMH interface. Counter saturates when COMM_COMH_RC_STAT1[VALIDH] and COMM_COMH_RC_STAT1[VALIDL] reach 0xFFFF. The counter is reset and register is cleared when read. All of the COMM_COMH_*_STAT* registers are updated and latched when COMM_COMH_RC_STAT3 is read to ensure all counter data refers to the same period of time.							

**8.6.1.371 Register: COMM\_UART\_TR\_STAT1**

COMM_UART_TR_STAT1 Register Address: 0x271							
B7	B6	B5	B4	B3	B2	B1	B0
SENTH[7]	SENTH[6]	SENTH[5]	SENTH[4]	SENTH[3]	SENTH[2]	SENTH[1]	SENTH[0]
0	0	0	0	0	0	0	0
R	R	R	R	R	R	R	R
SENTH[7:0] High byte of the counter for response frames transmitted over the UART interface. Counter saturates when COMM_UART_TR_STAT1[SENTH] and COMM_UART_TR_STAT2[SENTH] reach 0xFFFF. This counter is reset and the register is cleared when read. All of the COMM_UART_*_* registers are updated and latched when COMM_UART_RC_STAT3 is read to ensure all counter data refers to the same period of time.							

**8.6.1.372 Register: COMM\_UART\_TR\_STAT2**

COMM_UART_TR_STAT2 Register Address: 0x272							
B7	B6	B5	B4	B3	B2	B1	B0
SENTL[7]	SENTL[6]	SENTL[5]	SENTL[4]	SENTL[3]	SENTL[2]	SENTL[1]	SENTL[0]
0	0	0	0	0	0	0	0
R	R	R	R	R	R	R	R
SENTL[7:0] Low byte of the counter for response frames transmitted over the UART interface. Counter saturates when COMM_UART_TR_STAT1[SENTH] and COMM_UART_TR_STAT2[SENTL] reach 0xFFFF. The COMM_UART_*_STAT* registers are updated and the counters are reset when the COMM_UART_RC_STAT3 register is read to ensure all counter data refers to the same period of time.							

**8.6.1.373 Register: COMM\_COML\_TR\_STAT1**

COMM_COML_TR_STAT1 Register Address: 0x273							
B7	B6	B5	B4	B3	B2	B1	B0
SENTH[7]	SENTH[6]	SENTH[5]	SENTH[4]	SENTH[3]	SENTH[2]	SENTH[1]	SENTH[0]
0	0	0	0	0	0	0	0
R	R	R	R	R	R	R	R
SENTH[7:0] High byte of the counter for response frames transmitted over the COML interface. Counter saturates when COMM_COML_TR_STAT1[SENTH] and COMM_COML_TR_STAT2[SENTL] reach 0xFFFF. The COMM_COML_*_STAT* registers are updated and the counters are reset when the COMM_COML_RC_STAT3 register is read to ensure all counter data refers to the same period of time.							

**8.6.1.374 Register: COMM\_COML\_TR\_STAT2**

COMM_COML_TR_STAT2 Register Address: 0x274							
B7	B6	B5	B4	B3	B2	B1	B0
SENTL[7]	SENTL[6]	SENTL[5]	SENTL[4]	SENTL[3]	SENTL[2]	SENTL[1]	SENTL[0]
0	0	0	0	0	0	0	0
R	R	R	R	R	R	R	R
SENTL[7:0] Low byte of the counter for response frames transmitted over the COML interface. Counter saturates when COMM_COML_TR_STAT1[SENTH] and COMM_COML_TR_STAT2[SENTL] reach 0xFFFF. The COMM_COML_*_STAT* registers are updated and the counters are reset when the COMM_COML_RC_STAT3 register is read to ensure all counter data refers to the same period of time.							

**8.6.1.375 Register: COMM\_COMH\_RC\_STAT1**

COMM_COMH_RC_STAT1 Register Address: 0x275							
B7	B6	B5	B4	B3	B2	B1	B0
VALIDH[7]	VALIDH[6]	VALIDH[5]	VALIDH[4]	VALIDH[3]	VALIDH[2]	VALIDH[1]	VALIDH[0]
0	0	0	0	0	0	0	0
R	R	R	R	R	R	R	R
VALIDH[7:0] High byte of the valid command counter for received command frames from the COMH interface. Valid commands are command frames with no errors and a valid CRC. Counter saturates when COMM_COMH_RC_STAT1[VALIDH] and COMM_COMH_RC_STAT2[VALIDL] reach 0xFFFF. The COMM_COMH_*_STAT* registers are updated and the counters are reset when the COMM_COMH_RC_STAT3 register is read to ensure all counter data refers to the same period of time.							

**8.6.1.376 Register: COMM\_COMH\_RC\_STAT2**

COMM_COMH_RC_STAT2 Register Address: 0x276							
B7	B6	B5	B4	B3	B2	B1	B0
VALIDL[7]	VALIDL[6]	VALIDL[5]	VALIDL[4]	VALIDL[3]	VALIDL[2]	VALIDL[1]	VALIDL[0]
0	0	0	0	0	0	0	0
R	R	R	R	R	R	R	R
VALIDL[7:0] High byte of the valid command counter for received command frames from the COMH interface. Valid commands are command frames with no errors and a valid CRC. Counter saturates when COMM_COMH_RC_STAT1[VALIDH] and COMM_COMH_RC_STAT2[VALIDL] reach 0xFFFF. The counter is reset and register is cleared when read. All of the COMM_COMH_*_STAT* registers are updated and latched when COMM_COMH_RC_STAT1 is read to ensure all counter data refers to the same period of time.							

**8.6.1.377 Register: COMM\_COML\_RR\_STAT1**

COMM_COML_RR_STAT1 Register Address: 0x277							
B7	B6	B5	B4	B3	B2	B1	B0
VALIDH[7]	VALIDH[6]	VALIDH[5]	VALIDH[4]	VALIDH[3]	VALIDH[2]	VALIDH[1]	VALIDH[0]
0	0	0	0	0	0	0	0
R	R	R	R	R	R	R	R
VALIDH[7:0] High byte of the valid command counter for received response frames from the COML interface. Counter saturates when COMM_COML_RC_STAT1[VALIDH] and COMM_COML_RC_STAT1[VALIDL] reach 0xFFFF. The COMM_COML_*_STAT* registers are updated and the counters are reset when the COMM_COML_RC_STAT3 register is read to ensure all counter data refers to the same period of time.							

**8.6.1.378 Register: COMM\_COML\_RR\_STAT2**

COMM_COML_RR_STAT2 Register Address: 0x278							
B7	B6	B5	B4	B3	B2	B1	B0
VALIDL[7]	VALIDL[6]	VALIDL[5]	VALIDL[4]	VALIDL[3]	VALIDL[2]	VALIDL[1]	VALIDL[0]
0	0	0	0	0	0	0	0
R	R	R	R	R	R	R	R
VALIDL[7:0] High byte of the valid command counter for received response frames from the COML interface. Counter saturates when COMM_COML_RC_STAT1[VALIDH] and COMM_COML_RC_STAT1[VALIDL] reach 0xFFFF. The COMM_COML_*_STAT* registers are updated and the counters are reset when the COMM_COML_RC_STAT3 register is read to ensure all counter data refers to the same period of time.							

**8.6.1.379 Register: COMM\_COMH\_TR\_STAT1**

COMM_COMH_TR_STAT1 Register Address: 0x279							
B7	B6	B5	B4	B3	B2	B1	B0
SENTH[7]	SENTH[6]	SENTH[5]	SENTH[4]	SENTH[3]	SENTH[2]	SENTH[1]	SENTH[0]
0	0	0	0	0	0	0	0
R	R	R	R	R	R	R	R
SENTH[7:0] High byte of the counter for response frames transmitted over the COMH interface. Counter saturates when COMM_COMH_TR_STAT1[SENTH] and COMM_COMH_TR_STAT2[SENTH] reach 0xFFFF. The COMM_COMH_*_STAT* registers are updated and the counters are reset when the COMM_COMH_RR_STAT3 register is read to ensure all counter data refers to the same period of time.							

**8.6.1.380 Register: COMM\_COMH\_TR\_STAT2**

COMM_COMH_TR_STAT2 Register Address: 0x27A							
B7	B6	B5	B4	B3	B2	B1	B0
SENTH[7]	SENTH[6]	SENTH[5]	SENTH[4]	SENTH[3]	SENTH[2]	SENTH[1]	SENTH[0]
0	0	0	0	0	0	0	0
R	R	R	R	R	R	R	R
SENTH[7:0] Low byte of the counter for response frames transmitted over the COMH interface. Counter saturates when COMM_COMH_TR_STAT1[SENTH] and COMM_COMH_TR_STAT2[SENTH] reach 0xFFFF. The COMM_COMH_*_STAT* registers are updated and the counters are reset when the COMM_COMH_RR_STAT3 register is read to ensure all counter data refers to the same period of time.							

**8.6.1.381 Register: COMM\_UART\_RR\_STAT1**

COMM_UART_RR_STAT1 Register Address: 0x27B							
B7	B6	B5	B4	B3	B2	B1	B0
VALIDH[7]	VALIDH[6]	VALIDH[5]	VALIDH[4]	VALIDH[3]	VALIDH[2]	VALIDH[1]	VALIDH[0]
0	0	0	0	0	0	0	0
R	R	R	R	R	R	R	R
VALIDH[7:0] High byte of the valid command counter for received response frames from the UART interface. Counter saturates when COMM_UART_RC_STAT1[VALIDH] and COMM_UART_RC_STAT1[VALIDL] reach 0xFFFF. The COMM_UART_*_STAT* registers are updated and the counters are reset when the COMM_UART_RC_STAT3 register is read to ensure all counter data refers to the same period of time.							

**8.6.1.382 Register: COMM\_UART\_RR\_STAT2**

COMM_UART_RR_STAT2 Register Address: 0x27C							
B7	B6	B5	B4	B3	B2	B1	B0
VALIDL[7]	VALIDL[6]	VALIDL[5]	VALIDL[4]	VALIDL[3]	VALIDL[2]	VALIDL[1]	VALIDL[0]
0	0	0	0	0	0	0	0
R	R	R	R	R	R	R	R
VALIDL[7:0] High byte of the valid command counter for received response frames from the UART interface. Counter saturates when COMM_UART_RC_STAT1[VALIDH] and COMM_UART_RC_STAT1[VALIDL] reach 0xFFFF. The COMM_UART_*_STAT* registers are updated and the counters are reset when the COMM_UART_RC_STAT3 register is read to ensure all counter data refers to the same period of time.							

**8.6.1.383 Register: OTP\_PROG\_STAT**

OTP_PROG_STAT Register Address: 0x27D							
B7	B6	B5	B4	B3	B2	B1	B0
RSVD	UNLOCK	UVERR	OVERR	SUVERR	SOVERR	PROGERR	DONE
0	0	0	0	0	0	0	0
R	R	R	R	R	R	R	R
RSVD	reserved						
UNLOCK	Indicates the OTP programming unlock status. This bit is cleared with one of the following conditions: 1) any register writing other than OTP_PROG_CTRL 2) writing 1 to PROG_GO in OTP_PROG_CTRL (See Programming NVM section for details on unlocking the OTP) 0: Locked 1: Unlocked						
UVERR	Indicates a VPROG under-voltage error detected during OTP programming (See Programming NVM section for details) 0: No error 1: Error (Cleared with OTP_PROG_CTRL[PROG_GO] = 1)						
OVERR	Indicates a VPROG over-voltage error detected during OTP programming (See Programming NVM section for details) 0: No error 1: Error (Cleared with OTP_PROG_CTRL[PROG_GO] = 1)						
SUVERR	Indicates a VPROG under-voltage error detected during voltage stability test (See Programming NVM section for details on the voltage stability test) 0: No error 1: Error (Cleared with OTP_PROG_CTRL[PROG_GO] = 1)						
SOVERR	Indicates a VPROG over-voltage error detected during voltage stability test (See Programming NVM section for details on the voltage stability test) 0: No error 1: Error (Cleared with OTP_PROG_CTRL[PROG_GO] = 1)						
PROGERR	Indicates when an error detected due to incorrect page setting such as attempting to program an already programmed OTP page.. 0: No error or programming not attempted 1: Error (Cleared with OTP_PROG_CTRL[PROG_GO] = 1)						
DONE	Indicates the status of the OTP programming for the selected page. 0: Not completed or programming not attempted 1: Complete. (Cleared with OTP_PROG_CTRL[PROG_GO] = 1)						

**8.6.1.384 Register: OTP\_CUST1\_STAT1**

OTP_CUST1_STAT1 Register Address: 0x27E							
B7	B6	B5	B4	B3	B2	B1	B0
RSVD	LOADED	LOADWRN	LOADERR	FMterr	PROGOK	RETRY	FREE
0	0	0	0	0	0	0	1
R	R	R	R	R	R	R	R
RSVD	Reserved						
LOADED	Indicates OTP page 1 has been selected for loading into the related registers. See LOADERR and LOADWRN for error and warning status. 0: Not selected for loading 1: Page 1 selected for loading						
LOADWRN	Indicates OTP page 1 was loaded but with one or more SEC warnings. (See the "Error Check and Correct (ECC) OTP" section for details) 0: No warning, or no load load attempted 1: Warning						
LOADERR	Indicates an error while attempting to load OTP page 1. 0: No error, or no load was attempted. 1: Error						
FMterr	Indicates a formatting error in OTP page 1. For example, OTP_CUST1_STAT2[TRY2] is '1' but both OTP_CUST1_STAT2[TRY1] and OTP_CUST1_STAT2[UV1OK] are set 1. Do not program if a FMterr is set. 0: No error 1: Error						
PROGOK	Indicates the validity for loading for OTP page 1. A valid page indicates that successful programming occurred. (See Programming NVM section for details) 0: NOT valid 1: Valid						
RETRY	Indicates if OTP page 1 is available for a programming retry. Do not program if a FMterr is set. (See Programming NVM section for details). This bit is useful for prototype only. If this bit is flipped during production, the device needs to be taken out of service. 0: NOT available for programming retry 1: Available for programming retry						
FREE	Indicates the programming availability status of OTP page 1. Do not program if a FMterr is set. (See Programming NVM section for details). 0: NOT available 1: Available						

**8.6.1.385 Register: OTP\_CUST1\_STAT2**

OTP_CUST1_STAT2 Register Address: 0x27F							
B7	B6	B5	B4	B3	B2	B1	B0
RSVD[1]	RSVD[0]	TRY2	UV2OK	OV2OK	TRY1	UV1OK	OV1OK
0	0	0	0	0	0	0	0
R	R	R	R	R	R	R	R
RSVD[1:0]	Reserved						
TRY2	Indicates a second programming attempt for OTP page 1. 0: No second attempt made 1: Second attempt made						
UV2OK	Indicates a VPROG under-voltage condition detected during programming attempt #2 for OTP page 1. The UV condition will also trigger the UV as part of the shutdown process. 0: UV condition detected. Also reads as 0 if no programming attempt is performed. 1: No UV condition detected						
OV2OK	Indicates a VPROG over-voltage condition detected during programming attempt #2 for OTP page 1. The OV condition will trigger the UV as part of the shutdown process. The device should be taken out of service. 0: OV condition detected. Also reads as 0 if no programming attempt is performed. 1: No OV condition detected						
TRY1	Indicates a first programming attempt for OTP page 1. 0: No first attempt made 1: First attempt made						
UV1OK	Indicates a VPROG under-voltage condition detected during programming attempt #1 for OTP page 1. The UV condition will also trigger the UV as part of the shutdown process. 0: UV condition detected. Also reads as 0 if no programming attempt is performed. 1: No UV condition detected						
OV1OK	Indicates a VPROG over-voltage condition detected during programming attempt #1 for OTP page 1. The OV condition will trigger the UV as part of the shutdown process. The device should be taken out of service. 0: OV condition detected. Also reads as 0 if no programming attempt is performed. 1: No OV condition detected						



**8.6.1.386 Register: OTP\_CUST2\_STAT1**

OTP_CUST2_STAT1 Register Address: 0x280							
B7	B6	B5	B4	B3	B2	B1	B0
RSVD	LOADED	LOADWRN	LOADERR	FMTErr	PROGOK	RETRY	FREE
0	0	0	0	0	0	0	1
R	R	R	R	R	R	R	R
RSVD	Reserved						
LOADED	Indicates OTP page 2 has been selected for loading into the related registers. See LOADERR and LOADWRN for error and warning status. 0: Not selected for loading 1: Page 2 selected for loading						
LOADWRN	Indicates OTP page 2 was loaded but with one or more SEC warnings. (See the "Error Check and Correct (ECC) OTP" section for details) 0: No warning, or no load attempted 1: Warning						
LOADERR	Indicates an error while attempting to load OTP page 2. 0: No error, or no load was attempted. 1: Error						
FMTErr	Indicates a formatting error in OTP page 2. For example, OTP_CUST2_STAT2[TRY2] is '1' but both OTP_CUST2_STAT2[TRY1] and OTP_CUST1_STAT2[UV1OK] are set 1. Do not program if a FMTErr is set. 0: No error 1: Error						
PROGOK	Indicates the validity for loading for OTP page 2. A valid page indicates that successful programming occurred. (See Programming NVM section for details) 0: NOT valid 1: Valid						
RETRY	Indicates if OTP page 2 is available for a programming retry. Do not program if a FMTErr is set. (See Programming NVM section for details). This bit is useful for prototype only. If this bit is flipped during production, the device needs to be taken out of service. 0: NOT available for programming retry 1: Available for programming retry						
FREE	Indicates the programming availability status of OTP page 2. Do not program if a FMTErr is set. (See Programming NVM section for details) 0: NOT available 1: Available						

**8.6.1.387 Register: OTP\_CUST2\_STAT2**

OTP_CUST2_STAT2 Register Address: 0x281							
B7	B6	B5	B4	B3	B2	B1	B0
RSVD[1]	RSVD[0]	TRY2	UV2OK	OV2OK	TRY1	UV1OK	OV1OK
0	0	0	0	0	0	0	0
R	R	R	R	R	R	R	R
RSVD[1:0]	Reserved						
TRY2	Indicates a second programming attempt for OTP page 2. 0: No second attempt made 1: Second attempt made						
UV2OK	Indicates a VPROG under-voltage condition detected during programming attempt #2 for OTP page 2. The UV condition will also trigger the UV as part of the shutdown process. 0: UV condition detected. Also reads as 0 if no programming attempt is performed. 1: No UV condition detected						
OV2OK	Indicates a VPROG over-voltage condition detected during programming attempt #2 for OTP page 2. The OV condition will trigger the UV as part of the shutdown process. The device should be taken out of service. 0: OV condition detected. Also reads as 0 if no programming attempt is performed. 1: No OV condition detected						
TRY1	Indicates a first programming attempt for OTP page 2. 0: No first attempt made 1: First attempt made						
UV1OK	Indicates a VPROG under-voltage condition detected during programming attempt #1 for OTP page 2. The UV condition will also trigger the UV as part of the shutdown process. 0: UV condition detected. Also reads as 0 if no programming attempt is performed. 1: No UV condition detected						
OV1OK	Indicates a VPROG over-voltage condition detected during programming attempt #1 for OTP page 2. The OV condition will trigger the UV as part of the shutdown process. The device should be taken out of service. 0: OV condition detected. Also reads as 0 if no programming attempt is performed. 1: No OV condition detected						

### 8.6.1.388 Register: CB\_SW\_STAT

CB_SW_STAT Register Address: 0x282							
B7	B6	B5	B4	B3	B2	B1	B0
RSVD[1]	RSVD[0]	CELL6	CELL5	CELL4	CELL3	CELL2	CELL1
0	0	0	0	0	0	0	0
R	R	R	R	R	R	R	R
RSVD[1:0]		Reserved					
CELL6		Indicates the cell balancing switch control status for CELL6. 0: Switch off 1: Switch on					
CELL5		Indicates the cell balancing switch control status for CELL5. 0: Switch off 1: Switch on					
CELL4		Indicates the cell balancing switch control status for CELL4. 0: Switch off 1: Switch on					
CELL3		Indicates the cell balancing switch control status for CELL3. 0: Switch off 1: Switch on					
CELL2		Indicates the cell balancing switch control status for CELL2. 0: Switch off 1: Switch on					
CELL1		Indicates the cell balancing switch control status for CELL1. 0: Switch off 1: Switch on					

### 8.6.1.389 Register: GPIO\_FAULT

GPIO_FAULT Register Address: 0x290							
B7	B6	B5	B4	B3	B2	B1	B0
RSVD[1]	RSVD[0]	GPIO6	GPIO5	GPIO4	GPIO3	GPIO2	GPIO1
0	0	0	0	0	0	0	0
R	R	R	R	R	R	R	R
RSVD[1:0]		Reserved					
GPIO6		Indicates a fault condition on GPIO6. Only valid when GPIO6_CONF[FLT_EN] = 0b01 or 0b10. 0: No fault 1: Fault					
GPIO5		Indicates a fault condition on GPIO5. Only valid when GPIO5_CONF[FLT_EN] = 0b01 or 0b10. 0: No fault 1: Fault					
GPIO4		Indicates a fault condition on GPIO4. Only valid when GPIO4_CONF[FLT_EN] = 0b01 or 0b10. 0: No fault 1: Fault					
GPIO3		Indicates a fault condition on GPIO3. Only valid when GPIO3_CONF[FLT_EN] = 0b01 or 0b10. 0: No fault 1: Fault					
GPIO2		Indicates a fault condition on GPIO2. Only valid when GPIO2_CONF[FLT_EN] = 0b01 or 0b10. 0: No fault 1: Fault					
GPIO1		Indicates a fault condition on GPIO1. Only valid when GPIO1_CONF[FLT_EN] = 0b01 or 0b10. 0: No fault 1: Fault					

**8.6.1.390 Register: UV\_FAULT**

UV_FAULT Register Address: 0x291							
B7	B6	B5	B4	B3	B2	B1	B0
RSVD[1]	RSVD[0]	CELL6	CELL5	CELL4	CELL3	CELL2	CELL1
0	0	0	0	0	0	0	0
R	R	R	R	R	R	R	R
RSVD[1:0]		Reserved					
CELL6		Indicates an under-voltage fault on CELL6. Only valid when CELL6 hardware comparator is enabled. 0: No fault 1: Fault					
CELL5		Indicates an under-voltage fault on CELL5. Only valid when CELL5 hardware comparator is enabled. 0: No fault 1: Fault					
CELL4		Indicates an under-voltage fault on CELL4. Only valid when CELL4 hardware comparator is enabled. 0: No fault 1: Fault					
CELL3		Indicates an under-voltage fault on CELL3. Only valid when CELL3 hardware comparator is enabled. 0: No fault 1: Fault					
CELL2		Indicates an under-voltage fault on CELL2. Only valid when CELL2 hardware comparator is enabled. 0: No fault 1: Fault					
CELL1		Indicates an under-voltage fault on CELL1. Only valid when CELL1 hardware comparator is enabled. 0: No fault 1: Fault					

**8.6.1.391 Register: OV\_FAULT**

OV_FAULT Register Address: 0x292							
B7	B6	B5	B4	B3	B2	B1	B0
RSVD[1]	RSVD[0]	CELL6	CELL5	CELL4	CELL3	CELL2	CELL1
0	0	0	0	0	0	0	0
R	R	R	R	R	R	R	R
RSVD[1:0]		Reserved					
CELL6		Indicates an over-voltage fault on CELL6. Only valid when CELL6 hardware comparator is enabled. 0: No fault 1: Fault					
CELL5		Indicates an over-voltage fault on CELL5. Only valid when CELL5 hardware comparator is enabled. 0: No fault 1: Fault					
CELL4		Indicates an over-voltage fault on CELL4. Only valid when CELL4 hardware comparator is enabled. 0: No fault 1: Fault					
CELL3		Indicates an over-voltage fault on CELL3. Only valid when CELL3 hardware comparator is enabled. 0: No fault 1: Fault					
CELL2		Indicates an over-voltage fault on CELL2. Only valid when CELL2 hardware comparator is enabled. 0: No fault 1: Fault					
CELL1		Indicates an over-voltage fault on CELL1. Only valid when CELL1 hardware comparator is enabled. 0: No fault 1: Fault					

**8.6.1.392 Register: UT\_FAULT**

UT_FAULT Register Address: 0x293							
B7	B6	B5	B4	B3	B2	B1	B0
RSVD[1]	RSVD[0]	GPIO6	GPIO5	GPIO4	GPIO3	GPIO2	GPIO1
0	0	0	0	0	0	0	0
R	R	R	R	R	R	R	R
RSVD[1:0]		Reserved					
GPIO6		Indicates an under-temperature fault on GPIO6. Only valid when GPIO6 hardware comparator is enabled. All bits in UT_FAULT show a fault when TSREF is disabled and the UT function is enabled. 0: No fault 1: Fault					
GPIO5		Indicates an under-temperature fault on GPIO5. Only valid when GPIO5 hardware comparator is enabled. All bits in UT_FAULT show a fault when TSREF is disabled and the UT function is enabled. 0: No fault 1: Fault					
GPIO4		Indicates an under-temperature fault on GPIO4. Only valid when GPIO4 hardware comparator is enabled. All bits in UT_FAULT show a fault when TSREF is disabled and the UT function is enabled. 0: No fault 1: Fault					
GPIO3		Indicates an under-temperature fault on GPIO3. Only valid when GPIO3 hardware comparator is enabled. All bits in UT_FAULT show a fault when TSREF is disabled and the UT function is enabled. 0: No fault 1: Fault					
GPIO2		Indicates an under-temperature fault on GPIO2. Only valid when GPIO2 hardware comparator is enabled. All bits in UT_FAULT show a fault when TSREF is disabled and the UT function is enabled. 0: No fault 1: Fault					
GPIO1		Indicates an under-temperature fault on GPIO1. Only valid when GPIO1 hardware comparator is enabled. All bits in UT_FAULT show a fault when TSREF is disabled and the UT function is enabled. 0: No fault 1: Fault					

**8.6.1.393 Register: OT\_FAULT**

OT_FAULT Register Address: 0x294							
B7	B6	B5	B4	B3	B2	B1	B0
RSVD[1]	RSVD[0]	GPIO6	GPIO5	GPIO4	GPIO3	GPIO2	GPIO1
0	0	0	0	0	0	0	0
R	R	R	R	R	R	R	R
RSVD[1:0]		Reserved					
GPIO6		Indicates an over-temperature fault on GPIO6. Only valid when GPIO6 hardware comparator is enabled. All bits in OT_FAULT show a fault when TSREF is disabled and the OT function is enabled. 0: No fault 1: Fault					
GPIO5		Indicates an over-temperature fault on GPIO5. Only valid when GPIO5 hardware comparator is enabled. All bits in OT_FAULT show a fault when TSREF is disabled and the OT function is enabled. 0: No fault 1: Fault					
GPIO4		Indicates an over-temperature fault on GPIO4. Only valid when GPIO4 hardware comparator is enabled. All bits in OT_FAULT show a fault when TSREF is disabled and the OT function is enabled. 0: No fault 1: Fault					
GPIO3		Indicates an over-temperature fault on GPIO3. Only valid when GPIO3 hardware comparator is enabled. All bits in OT_FAULT show a fault when TSREF is disabled and the OT function is enabled. 0: No fault 1: Fault					
GPIO2		Indicates an over-temperature fault on GPIO2. Only valid when GPIO2 hardware comparator is enabled. All bits in OT_FAULT show a fault when TSREF is disabled and the OT function is enabled. 0: No fault 1: Fault					
GPIO1		Indicates an over-temperature fault on GPIO1. Only valid when GPIO1 hardware comparator is enabled. All bits in OT_FAULT show a fault when TSREF is disabled and the OT function is enabled. 0: No fault 1: Fault					

**8.6.1.394 Register: TONE\_FAULT**

TONE_FAULT Register Address: 0x295							
B7	B6	B5	B4	B3	B2	B1	B0
RSVD[4]	RSVD[3]	RSVD[2]	RSVD[1]	RSVD[0]	FF_REC	HB_FAIL	HB_FAST
0	0	0	0	0	0	0	0
R	R	R	R	R	R	R	R
RSVD[4:0]	Reserved						
FF_REC	Indicates that a fault tone has been received. See "Daisy-chain FAULT Interface (Stack Devices)" for details 0: No fault 1: Fault						
HB_FAIL	Indicates that two consecutive heartbeat tones have not been received. If this bit is set to 1, ignore HB_FAST. See "Daisy-chain FAULT Interface (Stack Devices)" for details 0: No fault 1: Fault						
HB_FAST	Indicates that the heartbeat tone received too frequently. If the HB_FAIL is set to 1, ignore this bit. (See "Daisy-chain FAULT Interface (Stack Devices)" for details) 0: No fault 1: Fault						

**8.6.1.395 Register: COMM\_UART\_FAULT**

COMM_UART_FAULT Register Address: 0x296							
B7	B6	B5	B4	B3	B2	B1	B0
RSVD[4]	RSVD[3]	RSVD[2]	RSVD[1]	RSVD[0]	COMMCLR_DET	COMMRST_DET	STOP
0	0	0	0	0	0	0	0
R	R	R	R	R	R	R	R
RSVD[4:0]	Reserved						
COMMCLR_DET	Indicates when a communication break is detected. See "Communication Clear (Break) Detection" section for more details. 0: No fault 1: Fault						
COMMRST_DET	Indicates when a communication reset is detected. See "Communication Reset Detection" section for more details. 0: No fault 1: Fault						
STOP	Indicates an unexpected STOP condition is received. See the "UART Interface" section for more details. 0: No fault 1: Fault						

**8.6.1.396 Register: COMM\_UART\_RC\_FAULT**

COMM_UART_RC_FAULT Register Address: 0x297							
B7	B6	B5	B4	B3	B2	B1	B0
RSVD[1]	RSVD[0]	IERR	TXDIS	SOF	BERR	UNEXP	CRC
0	0	0	0	0	0	0	0
R	R	R	R	R	R	R	R
RSVD[1:0]	Reserved						
IERR	Indicates an invalid frame is received. The frame initialization byte received on the UART interface has a stop error, reserved command bits set, or is configured as a response frame (not in multidrop mode). Frame initialization bytes are the 1st byte after a break, or based on frame sequence. When in the multidrop configuration, IERR is also set when the first frame received after a break is a response frame. When an initialization byte error occurs, the UART disregards communication (i.e. CRC is not calculated and, therefore, no CRC error is indicated) and does not forward communication until a break/reset is received. Note that in multi drop, during stack read, stack write, reverse direction this bit will not be flipped. Only reverse direction will create an IERR error. 0: No fault 1: Fault						
TXDIS	Indicates read command frame(s) were discarded because the TX is disabled on the UART. 0: No fault 1: Fault						
SOF	Indicates a start of frame error (break is received on the UART before the current frame is finished) 0: No fault 1: Fault						
BERR	Indicates frame(s) were discarded due to byte error on the second or later byte of a frame (STOP error not caused by a communications clear <BRK>). When a byte error occurs, the UART disregards further communication (i.e. CRC is not calculated and, therefore, no CRC error is indicated) and does not forward communication in non-multidrop mode until a break/reset is received. Note that nothing is forwarded in multidrop mode. In non multidrop configuration, if commands from the host and the responses from the stack devices come at the same time, an error can be triggered. When an initialization byte error occurs, the UART disregards communication (i.e. CRC is not calculated and, therefore, no CRC error is indicated) and does not forward communication until a break/reset is received. 0: No fault 1: Fault						
UNEXP	Indicates that a broadcast or stack command frame was received and discarded on the UART interface of a device that is configured as a stack device (CONFIG[STACK_DEV]=1) in a non-multidrop (CONFIG[MULTIDROP_EN]=0) configuration. This does not apply for multidrop configuration. 0: No fault 1: Fault						
CRC	Indicates a CRC error that resulted in one or more UART command frames being discarded. Any other errors in the frame are not indicated as the frame was discarded. 0: No fault 1: Fault						

**8.6.1.397 Register: COMM\_UART\_RR\_FAULT**

COMM_UART_RR_FAULT Register Address: 0x298							
B7	B6	B5	B4	B3	B2	B1	B0
RSVD[1]	RSVD[0]	RSVD	RSVD	SOF	BERR	RSVD	CRC
0	0	0	0	0	0	0	0
R	R	R	R	R	R	R	R
RSVD[1:0]	Reserved						
RSVD	Reserved						
RSVD	Reserved						
SOF	Indicates a start of frame error (break is received on the UART before the current frame is finished). Note that response frames on the UART only apply in multidrop mode. 0: No fault 1: Fault						
BERR	Indicates frame(s) were discarded due to byte error on the second or later byte of a frame (STOP error not caused by a communications clear <BRK>). Note that response frames on the UART only apply in multidrop mode. When an initialization byte error occurs, the UART disregards communication (i.e. CRC is not calculated and, therefore, no CRC error is indicated) and does not forward communication until a break/reset is received. 0: No fault 1: Fault						
RSVD	Reserved						
CRC	Indicates a CRC error that resulted in one or more UART response frames being discarded. Any other errors in the frame are not indicated as the frame was discarded. Note that response frames on the UART only apply in multidrop mode. 0: No fault 1: Fault						

**8.6.1.398 Register: COMM\_UART\_TR\_FAULT**

COMM_UART_TR_FAULT Register Address: 0x299							
B7	B6	B5	B4	B3	B2	B1	B0
RSVD[5]	RSVD[4]	RSVD[3]	RSVD[2]	RSVD[1]	RSVD[0]	SOF	WAIT
0	0	0	0	0	0	0	0
R	R	R	R	R	R	R	R
RSVD[5:0]		Reserved					
SOF		Indicates that a communication break is received while a transmission is in process on the UART interface. 0: No fault 1: Fault					
WAIT		Indicates that the device was unable to send the response frame for the previous read command on the UART due to receiving a communication break from the UART or a new command from any interface before receiving the response from the device above this one. Valid for broadcast and stack read commands only. Note that these new commands are not checked for the TXDIS or UNEXP conditions prior to causing the termination of the currently waiting command. See the "Communication Clear (Break) Detection" section for more details. 0: No fault 1: Fault					

**8.6.1.399 Register: COMM\_COMH\_FAULT**

COMM_COMH_FAULT Register Address: 0x29A							
B7	B6	B5	B4	B3	B2	B1	B0
RSVD[1]	RSVD[0]	BERR	DATA_MISS	DATA_ORDER	SYNC2	SYNC1	BIT
0	0	0	0	0	0	0	0
R	R	R	R	R	R	R	R
RSVD[1:0]		Reserved					
BERR		Indicates that the byte error has occurred in a received byte on the COMH interface. BERR is set when a COMH received byte has the byte error bit set, or when a received byte has detected one or more error during demodulation such as sync1, sync2, bit, data_order or data_miss error. 0: No fault 1: Fault					
DATA_MISS		Indicates that there has been a failure to detect a '1' or '0' on the COMH bus when one was expected. DATA_MISS is set if a valid data value is not received for longer than the expected bit time. 0: No fault 1: Fault					
DATA_ORDER		Indicates that at least one of the received data bits on the COMH bus does not have the expected complement bit structure. See the "Daisy Chain" section for more details. 0: No fault 1: Fault					
SYNC2		Indicates that the timing information extracted from the demodulation of the preamble half-bit and the two full bits of synchronization on the COMH bus is outside of the expected window. It is likely that the data is not sampled correctly. This error indicates noise has corrupted the timing information in the first bits of the communicated data. 0: No fault 1: Fault					
SYNC1		Indicates that the demodulation of the preamble half-bit and the two full bits of synchronization data on the COMH bus have errors and the timing is likely not correct. This error indicates noise has corrupted the timing information in the first bits of the communicated data. Clear this fault bit any time the vertical interface is disabled and then re-enabled. 0: No fault 1: Fault					
BIT		Indicates that the demodulation of the COMH bus traffic has received a data bit which is not a strong '1' or '0'. Occurs when not enough samples are received to guarantee a solid logic level, or if a bit is corrupted due to noise. 0: No fault 1: Fault					

### 8.6.1.400 Register: COMM\_COMH\_RC\_FAULT

COMM_COMH_RC_FAULT Register Address: 0x29B							
B7	B6	B5	B4	B3	B2	B1	B0
RSVD[1]	RSVD[0]	IERR	TXDIS	SOF	BERR	UNEXP	CRC
0	0	0	0	0	0	0	0
R	R	R	R	R	R	R	R
RSVD[1:0]	Reserved						
IERR	Will be set any time COMH vertical interface block has detected a physical layer fault on its initialization byte. This error can be caused one or more of faults as seen in physical layer at vertical interface register "COMM_COMH_FAULT". This bit is also set when a frame initialization byte is expected, but the SOF bit of the received byte is not set or an invalid frame type (one of the reserved commands) is selected. When this error occurs, communication is disregarded until an SOF byte is received. Any bytes received during this fault condition are forwarded, but are not processed by the device (i.e. CRC is not calculated and, therefore, no CRC error is indicated). Note: This bit can be set for both RC and RR. 0: No fault 1: Fault						
TXDIS	Indicates read command frame(s) were discarded because the TX is disabled on COMH (Given DIR_SEL=1). 0: No fault 1: Fault						
SOF	Indicates a start of frame error on COMH (frame start bit of '1' is received before the current frame is finished) 0: No fault 1: Fault						
BERR	Will be set any time COMH vertical interface block has detected a physical layer fault on the second or later byte of a frame. This error can be caused one or more of faults as seen in physical layer at vertical interface register "COMM_COMH_FAULT". This is also can be set when a received data is interrupted by a transmit transit byte (came from UART to VIF, valid only on the base device). 0: No fault 1: Fault						
UNEXP	This bit is set if a command is received by COMMH when CONTROL1[DIR_SEL]=0. 0: No fault 1: Fault						
CRC	Indicates a CRC error that resulted in one or more COMH command frames being discarded. Any other errors in the frame are not indicated as the frame was discarded. 0: No fault 1: Fault						

### 8.6.1.401 Register: COMM\_COMH\_RR\_FAULT

COMM_COMH_RR_FAULT Register Address: 0x29C							
B7	B6	B5	B4	B3	B2	B1	B0
RSVD[1]	RSVD[0]	RSVD	TXDIS	SOF	BERR	UNEXP	CRC
0	0	0	0	0	0	0	0
R	R	R	R	R	R	R	R
RSVD[1:0]	Reserved						
RSVD	Reserved						
TXDIS	Given the transmit direction to normal direction with CONTROL[DIR_SEL]=0. This bit indicates a RR discard due to COMH TX being disabled (stack device) or UART TX being disabled (base device). 0: No fault 1: Fault						
SOF	Indicates a start of frame error on COMH (frame start bit of '1' is received before the current frame is finished) 0: No fault 1: Fault						
BERR	Will be set any time COMH vertical interface block has detected a physical layer fault on the second or later byte of a frame. This error can be caused one or more of faults as seen in physical layer at vertical interface register "COMM_COMH_FAULT". This is also can be set when a received data is interrupted by a transmit transit byte (came from UART to VIF, valid only on the base device). 0: No fault 1: Fault						
UNEXP	This bit is set if a response is received by COMH when CONTROL1[DIR_SEL]=1. 0: No fault 1: Fault						
CRC	Indicates a CRC error that resulted in one or more COMH response frames being discarded. Most other errors in the frame are not indicated as the frame was discarded. If BERR is observed on the final byte of the CRC, both CRC and BERR will indicated. 0: No fault 1: Fault						



**8.6.1.402 Register: COMM\_COMH\_TR\_FAULT**

COMM_COMH_TR_FAULT Register Address: 0x29D							
B7	B6	B5	B4	B3	B2	B1	B0
RSVD[5]	RSVD[4]	RSVD[3]	RSVD[2]	RSVD[1]	RSVD[0]	RSVD	WAIT
0	0	0	0	0	0	0	0
R	R	R	R	R	R	R	R
RSVD[5:0]	Reserved						
RSVD	Reserved						
WAIT	Indicates that the device was unable to send the response frame for the previous read command on the COMH due to receiving a new command from any interface before receiving the response from the device below this one. Valid for broadcast and stack read commands only. Note that these new commands are not checked for the TXDIS or UNEXP conditions prior to causing the termination of the currently waiting command. 0: No fault 1: Fault						

**8.6.1.403 Register: COMM\_COML\_FAULT**

COMM_COML_FAULT Register Address: 0x29E							
B7	B6	B5	B4	B3	B2	B1	B0
RSVD[1]	RSVD[0]	BERR	DATA_MISS	DATA_ORDER	SYNC2	SYNC1	BIT
0	0	0	0	0	0	0	0
R	R	R	R	R	R	R	R
RSVD[1:0]	Reserved						
BERR	Indicates that the byte error has occurred in a received byte on the COMH interface. BERR is set when a COMH received byte has the byte error bit set, or when a received byte has detected one or more error during demodulation such as sync1, sync2, bit, data_order or data_miss error. This is also can be set when a received data is interrupted by a transmit transit byte (came from UART to VIF, valid only on the base device). 0: No fault 1: Fault						
DATA_MISS	Indicates that there has been a failure to detect a '1' or '0' on the COML bus when one was expected. DATA_MISS is set if a valid data value is not received for longer that the expected bit time. 0: No fault 1: Fault						
DATA_ORDER	Indicates that at least one of the received data bits on the COML bus does not have the expected complement bit structure. See the "Daisy Chain" section for more details. 0: No fault 1: Fault						
SYNC2	Indicates that the timing information extracted from the demodulation of the preamble half-bit and the two full bits of synchronization on the COML bus is outside of the expected window. It is likely that the data is not sampled correctly. This error indicates noise has corrupted the timing information in the first bits of the communicated data. 0: No fault 1: Fault						
SYNC1	Indicates that the demodulation of the preamble half-bit and the two full bits of synchronization data on the COML bus have errors and the timing is likely not correct. This error indicates noise has corrupted the timing information in the first bits of the communicated data. Clear this fault bit any time the vertical interface is disabled and then re-enabled. 0: No fault 1: Fault						
BIT	Indicates that the demodulation of the COML bus traffic has received a data bit which is not a strong '1' or '0'. Occurs when not enough samples are received to guarantee a solid logic level, or if a bit is corrupted due to noise. 0: No fault 1: Fault						

**8.6.1.404 Register: COMM\_COML\_RC\_FAULT**

COMM_COML_RC_FAULT Register Address: 0x29F							
B7	B6	B5	B4	B3	B2	B1	B0
RSVD[1]	RSVD[0]	IERR	TXDIS	SOF	BERR	UNEXP	CRC
0	0	0	0	0	0	0	0
R	R	R	R	R	R	R	R
RSVD[1:0]		Reserved					
IERR		Will be set any time COML vertical interface block has detected a physical layer fault on its initialization byte. This error can be caused one or more of faults as seen in physical layer at vertical interface register "COMM_COML_FAULT". This bit is also set when a frame initialization byte is expected, but the SOF bit of the received byte is not set or an invalid frame type (one of the reserved commands) is selected. When this error occurs, communication is disregarded until an SOF byte is received. Any bytes received during this fault condition are forwarded, but are not processed by the device (i.e. CRC is not calculated and, therefore, no CRC error is indicated). Note: This bit can be set for both RC and RR. 0: No fault 1: Fault					
TXDIS		Indicates read command frame(s) were discarded because the TX is disabled on COML (Given DIR_SEL=0). 0: No fault 1: Fault					
SOF		Indicates a start of frame error on COML (frame start bit of '1' is received before the current frame is finished) 0: No fault 1: Fault					
BERR		Will be set any time COML vertical interface block has detected a physical layer fault on the second or later byte of a frame. This error can be caused one or more of faults as seen in physical layer at vertical interface register "COMM_COML_FAULT". This is also can be set when a received data is interrupted by a transmit transit byte (came from UART to VIF, valid only on the base device). 0: No fault 1: Fault					
UNEXP		This bit is set if a command is received by COML when CONTROL1[DIR_SEL]=1. This also can be set if reverse command is received if DIR_SEL=0. 0: No fault 1: Fault					
CRC		Indicates a CRC error that resulted in one or more COML command frames being discarded. Any other errors in the frame are not indicated as the frame was discarded. 0: No fault 1: Fault					

**8.6.1.405 Register: COMM\_COML\_RR\_FAULT**

COMM_COML_RR_FAULT Register Address: 0x2A0							
B7	B6	B5	B4	B3	B2	B1	B0
RSVD[1]	RSVD[0]	RSVD	TXDIS	SOF	BERR	UNEXP	CRC
0	0	0	0	0	0	0	0
R	R	R	R	R	R	R	R
RSVD[1:0]		Reserved					
RSVD		Reserved					
TXDIS		Given the transmit direction is set to reverse direction with CONTROL[DIR_SEL]=1. This bit indicates a RR discard due to COMH TX being disabled (stack device) or UART TX being disabled (base device). 0: No fault 1: Fault					
SOF		Indicates a start of frame error on COML (frame start bit of '1' is received before the current frame is finished) 0: No fault 1: Fault					
BERR		Will be set any time COML vertical interface block has detected a physical layer fault on the second or later byte of a frame. This error can be caused one or more of faults as seen in physical layer at vertical interface register "COMM_COML_FAULT". This is also can be set when a received data is interrupted by a transmit transit byte (came from UART to VIF, valid only on the base device). 0: No fault 1: Fault					
UNEXP		This bit is set if a response is received by COML when CONTROL1[DIR_SEL]=0. 0: No fault 1: Fault					
CRC		Indicates a CRC error that resulted in one or more COML response frames being discarded. Most other errors in the frame are not indicated as the frame was discarded. If BERR is observed on the final byte of the CRC, both CRC and BERR will indicated. 0: No fault 1: Fault					

**8.6.1.406 Register: COMM\_COML\_TR\_FAULT**

COMM_COML_TR_FAULT Register Address: 0x2A1							
B7	B6	B5	B4	B3	B2	B1	B0
RSVD[5]	RSVD[4]	RSVD[3]	RSVD[2]	RSVD[1]	RSVD[0]	RSVD	WAIT
0	0	0	0	0	0	0	0
R	R	R	R	R	R	R	R
RSVD[5:0]	Reserved						
RSVD	Reserved						
WAIT	Indicates that the device was unable to send the response frame for the previous read command on the COML due to receiving a new command from any interface before receiving the response from the device above this one. Valid for broadcast and stack read commands only. Note that these new commands are not checked for the TXDIS or UNEXP conditions prior to causing the termination of the currently waiting command. 0: No fault 1: Fault						

**8.6.1.407 Register: OTP\_FAULT**

OTP_FAULT Register Address: 0x2A2							
B7	B6	B5	B4	B3	B2	B1	B0
RSVD[4]	RSVD[3]	RSVD[2]	RSVD[1]	RSVD[0]	CUSTLDERR	FACTLDERR	GBLOVERR
0	0	0	0	0	0	0	0
R	R	R	R	R	R	R	R
RSVD[4:0]	Reserved						
CUSTLDERR	Indicates errors during the customer space OTP load process. Read OTP_CUST1_STAT* and OTP_CUST2_STAT* for specific error condition. Some or all of the OTP did not load, depending on the circumstances and location of the DED error(s). The device may be partially or fully loaded with hardware defaults as specified in the summary table. 0: No fault 1: Fault						
FACTLDERR	Indicates errors during the factory space OTP load process. Some or all of the OTP did not load, depending on the circumstances and location of the DED error(s). The device may be partially or fully loaded with hardware defaults as specified in the summary table. Information received from the device with this error must not be considered reliable. 0: No fault 1: Fault						
GBLOVERR	Indicates that an over-voltage error is detected on one of the OTP pages. Read OTP_CUST1_STAT* and OTP_CUST2_STAT* to determine the specific page(s). Information received from the device with this error must not be considered reliable. 0: No fault 1: Fault						

**8.6.1.408 Register: RAIL\_FAULT**

RAIL_FAULT Register Address: 0x2A3							
B7	B6	B5	B4	B3	B2	B1	B0
AVDD_REFUV	TSREFOV	TSREFUV	VLDOOV	CVDDUV	DVDDOV	AVDDOV	AVDDUV_DRST
0	0	0	0	0	0	0	0
RW	R	R	R	R	R	R	R
AVDD_REFUV	Indicate that there is a difference of VAVDDREF_FLTZ between AVAO_REF rail and AVDDREF RAIL. 0: No fault 1: Fault						
TSREFOV	Indicates an over-voltage fault on the TSREF output. 0: No fault 1: Fault						
TSREFUV	Indicates an under-voltage fault on the TSREF output. 0: No fault 1: Fault						
VLDOOV	Indicates an over-voltage fault on the VLDO output. 0: No fault 1: Fault						
CVDDUV	Indicates an under-voltage fault on the CVDD input. 0: No fault 1: Fault						
DVDDOV	Indicates an over-voltage fault on the DVDD output. 0: No fault 1: Fault						
AVDDOV	Indicates an over-voltage fault on the AVDD output. 0: No fault 1: Fault						
AVDDUV_DRST	Indicates AVDD under-voltage fault happened during last digital reset. 0: No fault 1: Fault						

**8.6.1.409 Register: OVUV\_BIST\_FAULT**

OVUV_BIST_FAULT Register Address: 0x2A4							
B7	B6	B5	B4	B3	B2	B1	B0
RSVD[5]	RSVD[4]	RSVD[3]	RSVD[2]	RSVD[1]	RSVD[0]	OVCOMP	UVCOMP
0	0	0	0	0	0	0	0
RW	RW	RW	RW	RW	RW	R	R
RSVD[5:0]	reserved						
OVCOMP	Indicates a fault occurred in the OV comparator (OVUV BIST must be enabled) 0: No fault 1: Fault						
UVCOMP	Indicates a fault occurred in the UV comparator (OVUV BIST must be enabled) 0: No fault 1: Fault						

**8.6.1.410 Register: OTUT\_BIST\_FAULT**

OTUT_BIST_FAULT Register Address: 0x2A5							
B7	B6	B5	B4	B3	B2	B1	B0
MUX6	MUX5	MUX4	MUX3	MUX2	MUX1	UTCOMP	OTCOMP
0	0	0	0	0	0	0	0
R	R	R	R	R	R	R	R
MUX6	Indicates a fault occurred in the GPIO6 channel of the OT/UT multiplexer (OTUT BIST must be enabled) 0: No fault 1: Fault						
MUX5	Indicates a fault occurred in the GPIO5 channel of the OT/UT multiplexer (OTUT BIST must be enabled) 0: No fault 1: Fault						
MUX4	Indicates a fault occurred in the GPIO4 channel of the OT/UT multiplexer (OTUT BIST must be enabled) 0: No fault 1: Fault						
MUX3	Indicates a fault occurred in the GPIO3 channel of the OT/UT multiplexer (OTUT BIST must be enabled) 0: No fault 1: Fault						
MUX2	Indicates a fault occurred in the GPIO2 channel of the OT/UT multiplexer (OTUT BIST must be enabled) 0: No fault 1: Fault						
MUX1	Indicates a fault occurred in the GPIO1 channel of the OT/UT multiplexer (OTUT BIST must be enabled) 0: No fault 1: Fault						
UTCOMP	Indicates a fault occurred in the UT comparator (OTUT BIST must be enabled) 0: No fault 1: Fault						
OTCOMP	Indicates a fault occurred in the OT comparator (OTUT BIST must be enabled) 0: No fault 1: Fault						

**8.6.1.411 Register: ECC\_DATAOUT0**

ECC_DATAOUT0 Register Address: 0x2B0							
B7	B6	B5	B4	B3	B2	B1	B0
DATA[7]	DATA[6]	DATA[5]	DATA[4]	DATA[3]	DATA[2]	DATA[1]	DATA[0]
0	0	0	0	0	0	0	0
R	R	R	R	R	R	R	R
DATA[7:0]	ECC_DATAOUT* bytes out the results of the ECC decoder/encoder tests. If ECC_TEST[ENC_DEC] = 0, ECC_DATAOUT7:ECC_DATAOUT0 are read to determine a successful decoder test. If ECC_TEST[ENC_DEC] = 1, ECC_DATAOUT8:ECC_DATAOUT0 are read to determine a successful encoder test. The correct result depends on the input to the test. See the ECC test section for more details.						

**8.6.1.412 Register: ECC\_DATAOUT1**

ECC_DATAOUT1 Register Address: 0x2B1							
B7	B6	B5	B4	B3	B2	B1	B0
DATA[7]	DATA[6]	DATA[5]	DATA[4]	DATA[3]	DATA[2]	DATA[1]	DATA[0]
0	0	0	0	0	0	0	0
R	R	R	R	R	R	R	R
DATA[7:0]	ECC_DATAOUT* bytes out the results of the ECC decoder/encoder tests. If ECC_TEST[ENC_DEC] = 0, ECC_DATAOUT7:ECC_DATAOUT0 are read to determine a successful decoder test. If ECC_TEST[ENC_DEC] = 1, ECC_DATAOUT8:ECC_DATAOUT0 are read to determine a successful encoder test. The correct result depends on the input to the test. See the ECC test section for more details.						

### 8.6.1.413 Register: ECC\_DATAOUT2

ECC_DATAOUT2 Register Address: 0x2B2							
B7	B6	B5	B4	B3	B2	B1	B0
DATA[7]	DATA[6]	DATA[5]	DATA[4]	DATA[3]	DATA[2]	DATA[1]	DATA[0]
0	0	0	0	0	0	0	0
R	R	R	R	R	R	R	R
DATA[7:0] ECC_DATAOUT* bytes out the results of the ECC decoder/encoder tests. If ECC_TEST[ENC_DEC] = 0, ECC_DATAOUT7:ECC_DATAOUT0 are read to determine a successful decoder test. If ECC_TEST[ENC_DEC] = 1, ECC_DATAOUT8:ECC_DATAOUT0 are read to determine a successful encoder test. The correct result depends on the input to the test. See the ECC test section for more details.							

### 8.6.1.414 Register: ECC\_DATAOUT3

ECC_DATAOUT3 Register Address: 0x2B3							
B7	B6	B5	B4	B3	B2	B1	B0
DATA[7]	DATA[6]	DATA[5]	DATA[4]	DATA[3]	DATA[2]	DATA[1]	DATA[0]
0	0	0	0	0	0	0	0
R	R	R	R	R	R	R	R
DATA[7:0] ECC_DATAOUT* bytes out the results of the ECC decoder/encoder tests. If ECC_TEST[ENC_DEC] = 0, ECC_DATAOUT7:ECC_DATAOUT0 are read to determine a successful decoder test. If ECC_TEST[ENC_DEC] = 1, ECC_DATAOUT8:ECC_DATAOUT0 are read to determine a successful encoder test. The correct result depends on the input to the test. See the ECC test section for more details.							

### 8.6.1.415 Register: ECC\_DATAOUT4

ECC_DATAOUT4 Register Address: 0x2B4							
B7	B6	B5	B4	B3	B2	B1	B0
DATA[7]	DATA[6]	DATA[5]	DATA[4]	DATA[3]	DATA[2]	DATA[1]	DATA[0]
0	0	0	0	0	0	0	0
R	R	R	R	R	R	R	R
DATA[7:0] ECC_DATAOUT* bytes out the results of the ECC decoder/encoder tests. If ECC_TEST[ENC_DEC] = 0, ECC_DATAOUT7:ECC_DATAOUT0 are read to determine a successful decoder test. If ECC_TEST[ENC_DEC] = 1, ECC_DATAOUT8:ECC_DATAOUT0 are read to determine a successful encoder test. The correct result depends on the input to the test. See the ECC test section for more details.							

### 8.6.1.416 Register: ECC\_DATAOUT5

ECC_DATAOUT5 Register Address: 0x2B5							
B7	B6	B5	B4	B3	B2	B1	B0
DATA[7]	DATA[6]	DATA[5]	DATA[4]	DATA[3]	DATA[2]	DATA[1]	DATA[0]
0	0	0	0	0	0	0	0
R	R	R	R	R	R	R	R
DATA[7:0] ECC_DATAOUT* bytes out the results of the ECC decoder/encoder tests. If ECC_TEST[ENC_DEC] = 0, ECC_DATAOUT7:ECC_DATAOUT0 are read to determine a successful decoder test. If ECC_TEST[ENC_DEC] = 1, ECC_DATAOUT8:ECC_DATAOUT0 are read to determine a successful encoder test. The correct result depends on the input to the test. See the ECC test section for more details.							

### 8.6.1.417 Register: ECC\_DATAOUT6

ECC_DATAOUT6 Register Address: 0x2B6							
B7	B6	B5	B4	B3	B2	B1	B0
DATA[7]	DATA[6]	DATA[5]	DATA[4]	DATA[3]	DATA[2]	DATA[1]	DATA[0]
0	0	0	0	0	0	0	0
R	R	R	R	R	R	R	R
DATA[7:0] ECC_DATAOUT* bytes out the results of the ECC decoder/encoder tests. If ECC_TEST[ENC_DEC] = 0, ECC_DATAOUT7:ECC_DATAOUT0 are read to determine a successful decoder test. If ECC_TEST[ENC_DEC] = 1, ECC_DATAOUT8:ECC_DATAOUT0 are read to determine a successful encoder test. The correct result depends on the input to the test. See the ECC test section for more details.							

**8.6.1.418 Register: ECC\_DATAOUT7**

ECC_DATAOUT7 Register Address: 0x2B7							
B7	B6	B5	B4	B3	B2	B1	B0
DATA[7]	DATA[6]	DATA[5]	DATA[4]	DATA[3]	DATA[2]	DATA[1]	DATA[0]
0	0	0	0	0	0	0	0
R	R	R	R	R	R	R	R
DATA[7:0] ECC_DATAOUT* bytes out the results of the ECC decoder/encoder tests. If ECC_TEST[ENC_DEC] = 0, ECC_DATAOUT7:ECC_DATAOUT0 are read to determine a successful decoder test. If ECC_TEST[ENC_DEC] = 1, ECC_DATAOUT8:ECC_DATAOUT0 are read to determine a successful encoder test. The correct result depends on the input to the test. See the ECC test section for more details.							

**8.6.1.419 Register: ECC\_DATAOUT8**

ECC_DATAOUT8 Register Address: 0x2B8							
B7	B6	B5	B4	B3	B2	B1	B0
DATA[7]	DATA[6]	DATA[5]	DATA[4]	DATA[3]	DATA[2]	DATA[1]	DATA[0]
0	0	0	0	0	0	0	0
R	R	R	R	R	R	R	R
DATA[7:0] ECC_DATAOUT* bytes out the results of the ECC decoder/encoder tests. If ECC_TEST[ENC_DEC] = 0, ECC_DATAOUT7:ECC_DATAOUT0 are read to determine a successful decoder test. If ECC_TEST[ENC_DEC] = 1, ECC_DATAOUT8:ECC_DATAOUT0 are read to determine a successful encoder test. The correct result depends on the input to the test. See the ECC test section for more details.							

**8.6.1.420 Register: SEC\_BLK**

SEC_BLK Register Address: 0x2B9							
B7	B6	B5	B4	B3	B2	B1	B0
BLOCK[7]	BLOCK[6]	BLOCK[5]	BLOCK[4]	BLOCK[3]	BLOCK[2]	BLOCK[1]	BLOCK[0]
0	0	0	0	0	0	0	0
R	R	R	R	R	R	R	R
BLOCK[7:0] Holds last OTP block address where SEC occurred (valid only when SYS_FAULT3[SEC_DETECT])							

**8.6.1.421 Register: DED\_BLK**

DED_BLK Register Address: 0x2BA							
B7	B6	B5	B4	B3	B2	B1	B0
BLOCK[7]	BLOCK[6]	BLOCK[5]	BLOCK[4]	BLOCK[3]	BLOCK[2]	BLOCK[1]	BLOCK[0]
0	0	0	0	0	0	0	0
R	R	R	R	R	R	R	R
BLOCK[7:0] Holds last OTP block address where DED occurred (valid only when SYS_FAULT3[DED_DETECT])							

**8.6.1.422 Register: DEV\_ADD\_STAT**

DEV_ADD_STAT Register Address: 0x2BB							
B7	B6	B5	B4	B3	B2	B1	B0
RSVD[1]	RSVD[0]	ADD[5]	ADD[4]	ADD[3]	ADD[2]	ADD[1]	ADD[0]
0	0	0	0	0	0	0	0
R	R	R	R	R	R	R	R
RSVD[1:0] Reserved							
ADD[5:0] Reflects the current device address.							

### 8.6.1.423 Register: COMM\_STAT

COMM_STAT Register Address: 0x2BC							
B7	B6	B5	B4	B3	B2	B1	B0
RSVD[3]	RSVD[2]	RSVD[1]	RSVD[0]	COMH_TONEBU SY	COML_TONEBU SY	BAUD_STAT[1]	BAUD_STAT[0]
0	0	0	0	0	0	0	0
R	R	R	R	R	R	R	R
RSVD[3:0]		Reserved					
COMH_TONEBU SY	Indicates COMH is sending a WAKE, SLPtoACT, or SHUTDOWN tone. 0: COMH not sending tone 1: COMH currently sending tone						
COML_TONEBU SY	Indicates COML is sending a WAKE, SLPtoACT, or SHUTDOWN tone. 0: COML not sending tone 1: COML currently sending tone						
BAUD_STAT[1:0]	Reflects the current device BAUD rate. This register is updated after communication reset or when the COMM_CTRL[BAUD] is written. 00: 125kbps 01: 250kbps 10: 500kbps 11: 1Mbps						

### 8.6.1.424 Register: DAISY\_CHAIN\_STAT

DAISY_CHAIN_STAT Register Address: 0x2BD							
B7	B6	B5	B4	B3	B2	B1	B0
RSVD[2]	RSVD[1]	RSVD[0]	HW_DRV	COMLTX	COMLRX	COMHTX	COMHRX
0	0	0	0	0	0	0	0
R	R	R	R	R	R	R	R
RSVD[2:0]		Reserved					
HW_DRV	Indicates whether hardware or the user has control over the COML and COMH interfaces. 0: Enable/disable set by the DAISY_CHAIN_CTRL register 1: Enable/disable set by the hardware						
COMLTX	Indicates the current status for the COML transmitter. 0: Disabled 1: Enabled						
COMLRX	Indicates the current status for the COML receiver. 0: Disabled 1: Enabled						
COMHTX	Indicates the current status for the COMH transmitter. 0: Disabled 1: Enabled						
COMHRX	Indicates the current status for the COMH receiver. 0: Disabled 1: Enabled						

### 8.6.1.425 Register: VCELL1\_HU

VCELL1_HU Register Address: 0x2C0							
B7	B6	B5	B4	B3	B2	B1	B0
RESULT[7]	RESULT[6]	RESULT[5]	RESULT[4]	RESULT[3]	RESULT[2]	RESULT[1]	RESULT[0]
1	0	0	0	0	0	0	0
R	R	R	R	R	R	R	R
RESULT[7:0]		Cell 1 Voltage High Byte 2s complement (Reference Uncorrected)					

### 8.6.1.426 Register: VCELL1\_MU

VCELL1_MU Register Address: 0x2C1							
B7	B6	B5	B4	B3	B2	B1	B0
RESULT[7]	RESULT[6]	RESULT[5]	RESULT[4]	RESULT[3]	RESULT[2]	RESULT[1]	RESULT[0]
0	0	0	0	0	0	0	0
R	R	R	R	R	R	R	R
RESULT[7:0]		Cell 1 Voltage Middle Byte 2s complement (Reference Uncorrected)					



**8.6.1.427 Register: VCELL1\_LU**

VCELL1_LU Register Address: 0x2C2							
B7	B6	B5	B4	B3	B2	B1	B0
RESULT[7]	RESULT[6]	RESULT[5]	RESULT[4]	RESULT[3]	RESULT[2]	RESULT[1]	RESULT[0]
0	0	0	0	0	0	0	0
R	R	R	R	R	R	R	R
RESULT[7:0] Cell 1 Voltage Low Byte 2s complement (Reference Uncorrected)							

**8.6.1.428 Register: VCELL2\_HU**

VCELL2_HU Register Address: 0x2C3							
B7	B6	B5	B4	B3	B2	B1	B0
RESULT[7]	RESULT[6]	RESULT[5]	RESULT[4]	RESULT[3]	RESULT[2]	RESULT[1]	RESULT[0]
1	0	0	0	0	0	0	0
R	R	R	R	R	R	R	R
RESULT[7:0] Cell 2 Voltage High Byte 2s complement (Reference Uncorrected)							

**8.6.1.429 Register: VCELL2\_MU**

VCELL2_MU Register Address: 0x2C4							
B7	B6	B5	B4	B3	B2	B1	B0
RESULT[7]	RESULT[6]	RESULT[5]	RESULT[4]	RESULT[3]	RESULT[2]	RESULT[1]	RESULT[0]
0	0	0	0	0	0	0	0
R	R	R	R	R	R	R	R
RESULT[7:0] Cell 2 Voltage Middle Byte 2s complement (Reference Uncorrected)							

**8.6.1.430 Register: VCELL2\_LU**

VCELL2_LU Register Address: 0x2C5							
B7	B6	B5	B4	B3	B2	B1	B0
RESULT[7]	RESULT[6]	RESULT[5]	RESULT[4]	RESULT[3]	RESULT[2]	RESULT[1]	RESULT[0]
0	0	0	0	0	0	0	0
R	R	R	R	R	R	R	R
RESULT[7:0] Cell 2 Voltage Low Byte 2s complement (Reference Uncorrected)							

**8.6.1.431 Register: VCELL3\_HU**

VCELL3_HU Register Address: 0x2C6							
B7	B6	B5	B4	B3	B2	B1	B0
RESULT[7]	RESULT[6]	RESULT[5]	RESULT[4]	RESULT[3]	RESULT[2]	RESULT[1]	RESULT[0]
1	0	0	0	0	0	0	0
R	R	R	R	R	R	R	R
RESULT[7:0] Cell 3 Voltage High Byte 2s complement (Reference Uncorrected)							

**8.6.1.432 Register: VCELL3\_MU**

VCELL3_MU Register Address: 0x2C7							
B7	B6	B5	B4	B3	B2	B1	B0
RESULT[7]	RESULT[6]	RESULT[5]	RESULT[4]	RESULT[3]	RESULT[2]	RESULT[1]	RESULT[0]
0	0	0	0	0	0	0	0
R	R	R	R	R	R	R	R
RESULT[7:0] Cell 3 Voltage Middle Byte 2s complement (Reference Uncorrected)							

**8.6.1.433 Register: VCELL3\_LU**

VCELL3_LU Register Address: 0x2C8							
B7	B6	B5	B4	B3	B2	B1	B0
RESULT[7]	RESULT[6]	RESULT[5]	RESULT[4]	RESULT[3]	RESULT[2]	RESULT[1]	RESULT[0]
0	0	0	0	0	0	0	0
R	R	R	R	R	R	R	R
RESULT[7:0] Cell 3 Voltage Low Byte 2s complement (Reference Uncorrected)							

**8.6.1.434 Register: VCELL4\_HU**

VCELL4_HU Register Address: 0x2C9							
B7	B6	B5	B4	B3	B2	B1	B0
RESULT[7]	RESULT[6]	RESULT[5]	RESULT[4]	RESULT[3]	RESULT[2]	RESULT[1]	RESULT[0]
1	0	0	0	0	0	0	0
R	R	R	R	R	R	R	R
RESULT[7:0] Cell 4 Voltage High Byte 2s complement (Reference Uncorrected)							

**8.6.1.435 Register: VCELL4\_MU**

VCELL4_MU Register Address: 0x2CA							
B7	B6	B5	B4	B3	B2	B1	B0
RESULT[7]	RESULT[6]	RESULT[5]	RESULT[4]	RESULT[3]	RESULT[2]	RESULT[1]	RESULT[0]
0	0	0	0	0	0	0	0
R	R	R	R	R	R	R	R
RESULT[7:0] Cell 4 Voltage Middle Byte 2s complement (Reference Uncorrected)							

**8.6.1.436 Register: VCELL4\_LU**

VCELL4_LU Register Address: 0x2CB							
B7	B6	B5	B4	B3	B2	B1	B0
RESULT[7]	RESULT[6]	RESULT[5]	RESULT[4]	RESULT[3]	RESULT[2]	RESULT[1]	RESULT[0]
0	0	0	0	0	0	0	0
R	R	R	R	R	R	R	R
RESULT[7:0] Cell 4 Voltage Low Byte 2s complement (Reference Uncorrected)							

**8.6.1.437 Register: VCELL5\_HU**

VCELL5_HU Register Address: 0x2CC							
B7	B6	B5	B4	B3	B2	B1	B0
RESULT[7]	RESULT[6]	RESULT[5]	RESULT[4]	RESULT[3]	RESULT[2]	RESULT[1]	RESULT[0]
1	0	0	0	0	0	0	0
R	R	R	R	R	R	R	R
RESULT[7:0] Cell 5 Voltage High Byte 2s complement (Reference Uncorrected)							

**8.6.1.438 Register: VCELL5\_MU**

VCELL5_MU Register Address: 0x2CD							
B7	B6	B5	B4	B3	B2	B1	B0
RESULT[7]	RESULT[6]	RESULT[5]	RESULT[4]	RESULT[3]	RESULT[2]	RESULT[1]	RESULT[0]
0	0	0	0	0	0	0	0
R	R	R	R	R	R	R	R
RESULT[7:0] Cell 5 Voltage Middle Byte 2s complement (Reference Uncorrected)							

**8.6.1.439 Register: VCELL5\_LU**

VCELL5_LU Register Address: 0x2CE							
B7	B6	B5	B4	B3	B2	B1	B0
RESULT[7]	RESULT[6]	RESULT[5]	RESULT[4]	RESULT[3]	RESULT[2]	RESULT[1]	RESULT[0]
0	0	0	0	0	0	0	0
R	R	R	R	R	R	R	R
RESULT[7:0] Cell 5 Voltage Low Byte 2s complement (Reference Uncorrected)							

**8.6.1.440 Register: VCELL6\_HU**

VCELL6_HU Register Address: 0x2CF							
B7	B6	B5	B4	B3	B2	B1	B0
RESULT[7]	RESULT[6]	RESULT[5]	RESULT[4]	RESULT[3]	RESULT[2]	RESULT[1]	RESULT[0]
1	0	0	0	0	0	0	0
R	R	R	R	R	R	R	R
RESULT[7:0] Cell 6 Voltage High Byte 2s complement (Reference Uncorrected)							

**8.6.1.441 Register: VCELL6\_MU**

VCELL6_MU Register Address: 0x2D0							
B7	B6	B5	B4	B3	B2	B1	B0
RESULT[7]	RESULT[6]	RESULT[5]	RESULT[4]	RESULT[3]	RESULT[2]	RESULT[1]	RESULT[0]
0	0	0	0	0	0	0	0
R	R	R	R	R	R	R	R
RESULT[7:0] Cell 6 Voltage Middle Byte 2s complement (Reference Uncorrected)							

**8.6.1.442 Register: VCELL6\_LU**

VCELL6_LU Register Address: 0x2D1							
B7	B6	B5	B4	B3	B2	B1	B0
RESULT[7]	RESULT[6]	RESULT[5]	RESULT[4]	RESULT[3]	RESULT[2]	RESULT[1]	RESULT[0]
0	0	0	0	0	0	0	0
R	R	R	R	R	R	R	R
RESULT[7:0] Cell 6 Voltage Low Byte 2s complement (Reference Uncorrected)							

**8.6.1.443 Register: AUX\_BAT\_HU**

AUX_BAT_HU Register Address: 0x2D2							
B7	B6	B5	B4	B3	B2	B1	B0
RESULT[7]	RESULT[6]	RESULT[5]	RESULT[4]	RESULT[3]	RESULT[2]	RESULT[1]	RESULT[0]
1	0	0	0	0	0	0	0
R	R	R	R	R	R	R	R
RESULT[7:0] Cell Stack Voltage High Byte (Reference Uncorrected)							

**8.6.1.444 Register: AUX\_BAT\_LU**

AUX_BAT_LU Register Address: 0x2D3							
B7	B6	B5	B4	B3	B2	B1	B0
RESULT[7]	RESULT[6]	RESULT[5]	RESULT[4]	RESULT[3]	RESULT[2]	RESULT[1]	RESULT[0]
0	0	0	0	0	0	0	0
R	R	R	R	R	R	R	R
RESULT[7:0] Cell Stack Voltage Low Byte (Reference Uncorrected)							

**8.6.1.445 Register: AUX\_GPIO1\_HU**

AUX_GPIO1_HU Register Address: 0x2D4							
B7	B6	B5	B4	B3	B2	B1	B0
RESULT[7]	RESULT[6]	RESULT[5]	RESULT[4]	RESULT[3]	RESULT[2]	RESULT[1]	RESULT[0]
1	0	0	0	0	0	0	0
R	R	R	R	R	R	R	R
RESULT[7:0] GPIO Input 1 High Byte (Reference Uncorrected) Ratiometric result when TS selected Reference correct voltage result when AUX is selected							

**8.6.1.446 Register: AUX\_GPIO1\_MU**

AUX_GPIO1_MU Register Address: 0x2D5							
B7	B6	B5	B4	B3	B2	B1	B0
RESULT[7]	RESULT[6]	RESULT[5]	RESULT[4]	RESULT[3]	RESULT[2]	RESULT[1]	RESULT[0]
0	0	0	0	0	0	0	0
R	R	R	R	R	R	R	R
RESULT[7:0] GPIO Input 1 Middle Byte Ratiometric result when TS selected Voltage result when AUX is selected							

**8.6.1.447 Register: AUX\_GPIO1\_LU**

AUX_GPIO1_LU Register Address: 0x2D6							
B7	B6	B5	B4	B3	B2	B1	B0
RESULT[7]	RESULT[6]	RESULT[5]	RESULT[4]	RESULT[3]	RESULT[2]	RESULT[1]	RESULT[0]
0	0	0	0	0	0	0	0
R	R	R	R	R	R	R	R
RESULT[7:0] GPIO Input 1 Low Byte (Reference Uncorrected) Ratiometric result when TS selected Voltage result when AUX is selected							

**8.6.1.448 Register: AUX\_GPIO2\_HU**

AUX_GPIO2_HU Register Address: 0x2D7							
B7	B6	B5	B4	B3	B2	B1	B0
RESULT[7]	RESULT[6]	RESULT[5]	RESULT[4]	RESULT[3]	RESULT[2]	RESULT[1]	RESULT[0]
1	0	0	0	0	0	0	0
R	R	R	R	R	R	R	R
RESULT[7:0] GPIO Input 2 High Byte (Reference Uncorrected) Ratiometric result when TS selected Reference correct voltage result when AUX is selected. Voltage result when AUX is selected.							

**8.6.1.449 Register: AUX\_GPIO2\_LU**

AUX_GPIO2_LU Register Address: 0x2D8							
B7	B6	B5	B4	B3	B2	B1	B0
RESULT[7]	RESULT[6]	RESULT[5]	RESULT[4]	RESULT[3]	RESULT[2]	RESULT[1]	RESULT[0]
0	0	0	0	0	0	0	0
R	R	R	R	R	R	R	R
RESULT[7:0] GPIO Input 2 Low Byte (Reference Uncorrected) Ratiometric result when TS selected Reference correct voltage result when AUX is selected							

**8.6.1.450 Register: AUX\_GPIO3\_HU**

AUX_GPIO3_HU Register Address: 0x2D9							
B7	B6	B5	B4	B3	B2	B1	B0
RESULT[7]	RESULT[6]	RESULT[5]	RESULT[4]	RESULT[3]	RESULT[2]	RESULT[1]	RESULT[0]
1	0	0	0	0	0	0	0
R	R	R	R	R	R	R	R
RESULT[7:0] GPIO Input 3 High Byte (Reference Uncorrected) Ratiometric result when TS selected Voltage result when AUX is selected							

**8.6.1.451 Register: AUX\_GPIO3\_LU**

AUX_GPIO3_LU Register Address: 0x2DA							
B7	B6	B5	B4	B3	B2	B1	B0
RESULT[7]	RESULT[6]	RESULT[5]	RESULT[4]	RESULT[3]	RESULT[2]	RESULT[1]	RESULT[0]
0	0	0	0	0	0	0	0
R	R	R	R	R	R	R	R
RESULT[7:0] GPIO Input 3 Low Byte (Reference Uncorrected) Ratiometric result when TS selected Voltage result when AUX is selected							

**8.6.1.452 Register: AUX\_GPIO4\_HU**

AUX_GPIO4_HU Register Address: 0x2DB							
B7	B6	B5	B4	B3	B2	B1	B0
RESULT[7]	RESULT[6]	RESULT[5]	RESULT[4]	RESULT[3]	RESULT[2]	RESULT[1]	RESULT[0]
1	0	0	0	0	0	0	0
R	R	R	R	R	R	R	R
RESULT[7:0] GPIO Input 4 High Byte (Reference Uncorrected) Ratiometric result when TS selected Voltage result when AUX is selected							

**8.6.1.453 Register: AUX\_GPIO4\_LU**

AUX_GPIO4_LU Register Address: 0x2DC							
B7	B6	B5	B4	B3	B2	B1	B0
RESULT[7]	RESULT[6]	RESULT[5]	RESULT[4]	RESULT[3]	RESULT[2]	RESULT[1]	RESULT[0]
0	0	0	0	0	0	0	0
R	R	R	R	R	R	R	R
RESULT[7:0] GPIO Input 4 Low Byte (Reference Uncorrected) Ratiometric result when TS selected Reference correct voltage result when AUX is selected							

**8.6.1.454 Register: AUX\_GPIO5\_HU**

AUX_GPIO5_HU Register Address: 0x2DD							
B7	B6	B5	B4	B3	B2	B1	B0
RESULT[7]	RESULT[6]	RESULT[5]	RESULT[4]	RESULT[3]	RESULT[2]	RESULT[1]	RESULT[0]
1	0	0	0	0	0	0	0
R	R	R	R	R	R	R	R
RESULT[7:0] GPIO Input 5 High Byte (Reference Uncorrected) Ratiometric result when TS selected Voltage result when AUX is selected							

**8.6.1.455 Register: AUX\_GPIO5\_LU**

AUX_GPIO5_LU Register Address: 0x2DE							
B7	B6	B5	B4	B3	B2	B1	B0
RESULT[7]	RESULT[6]	RESULT[5]	RESULT[4]	RESULT[3]	RESULT[2]	RESULT[1]	RESULT[0]
0	0	0	0	0	0	0	0
R	R	R	R	R	R	R	R
RESULT[7:0] GPIO Input 5 Low Byte (Reference Uncorrected) Ratiometric result when TS selected Voltage result when AUX is selected							

**8.6.1.456 Register: AUX\_GPIO6\_HU**

AUX_GPIO6_HU Register Address: 0x2DF							
B7	B6	B5	B4	B3	B2	B1	B0
RESULT[7]	RESULT[6]	RESULT[5]	RESULT[4]	RESULT[3]	RESULT[2]	RESULT[1]	RESULT[0]
1	0	0	0	0	0	0	0
R	R	R	R	R	R	R	R
RESULT[7:0] GPIO Input 6 High Byte Ratiometric result when TS selected Voltage result when AUX is selected							

**8.6.1.457 Register: AUX\_GPIO6\_LU**

AUX_GPIO6_LU Register Address: 0x2E0							
B7	B6	B5	B4	B3	B2	B1	B0
RESULT[7]	RESULT[6]	RESULT[5]	RESULT[4]	RESULT[3]	RESULT[2]	RESULT[1]	RESULT[0]
0	0	0	0	0	0	0	0
R	R	R	R	R	R	R	R
RESULT[7:0] GPIO Input 6 Low Byte (Reference Uncorrected) Ratiometric result when TS selected Voltage result when AUX is selected							

**8.6.1.458 Register: CUST\_CRC\_RSLTH**

CUST_CRC_RSLTH Register Address: 0x2E1							
B7	B6	B5	B4	B3	B2	B1	B0
CRCH[7]	CRCH[6]	CRCH[5]	CRCH[4]	CRCH[3]	CRCH[2]	CRCH[1]	CRCH[0]
0	0	0	0	0	0	0	0
R	R	R	R	R	R	R	R
CRCH[7:0] High byte of CRC result for Customer space							

**8.6.1.459 Register: CUST\_CRC\_RSLTL**

CUST_CRC_RSLTL Register Address: 0x2E2							
B7	B6	B5	B4	B3	B2	B1	B0
CRCL[7]	CRCL[6]	CRCL[5]	CRCL[4]	CRCL[3]	CRCL[2]	CRCL[1]	CRCL[0]
0	0	0	0	0	0	0	0
R	R	R	R	R	R	R	R
CRCL[7:0] Low byte of CRC result for Customer space							

## 9 Application and Implementation

---

### NOTE

Information in the following applications sections is not part of the TI component specification, and TI does not warrant its accuracy or completeness. TI's customers are responsible for determining suitability of components for their purposes. Customers should validate and test their design implementation to confirm system functionality.

---

### 9.1 Application Information

The BQ79606A-Q1 device provides simultaneous, high accuracy, channel measurements for three to six battery cells.

9.2 Typical Applications

9.2.1 Base Device with Measurement Applications Circuit

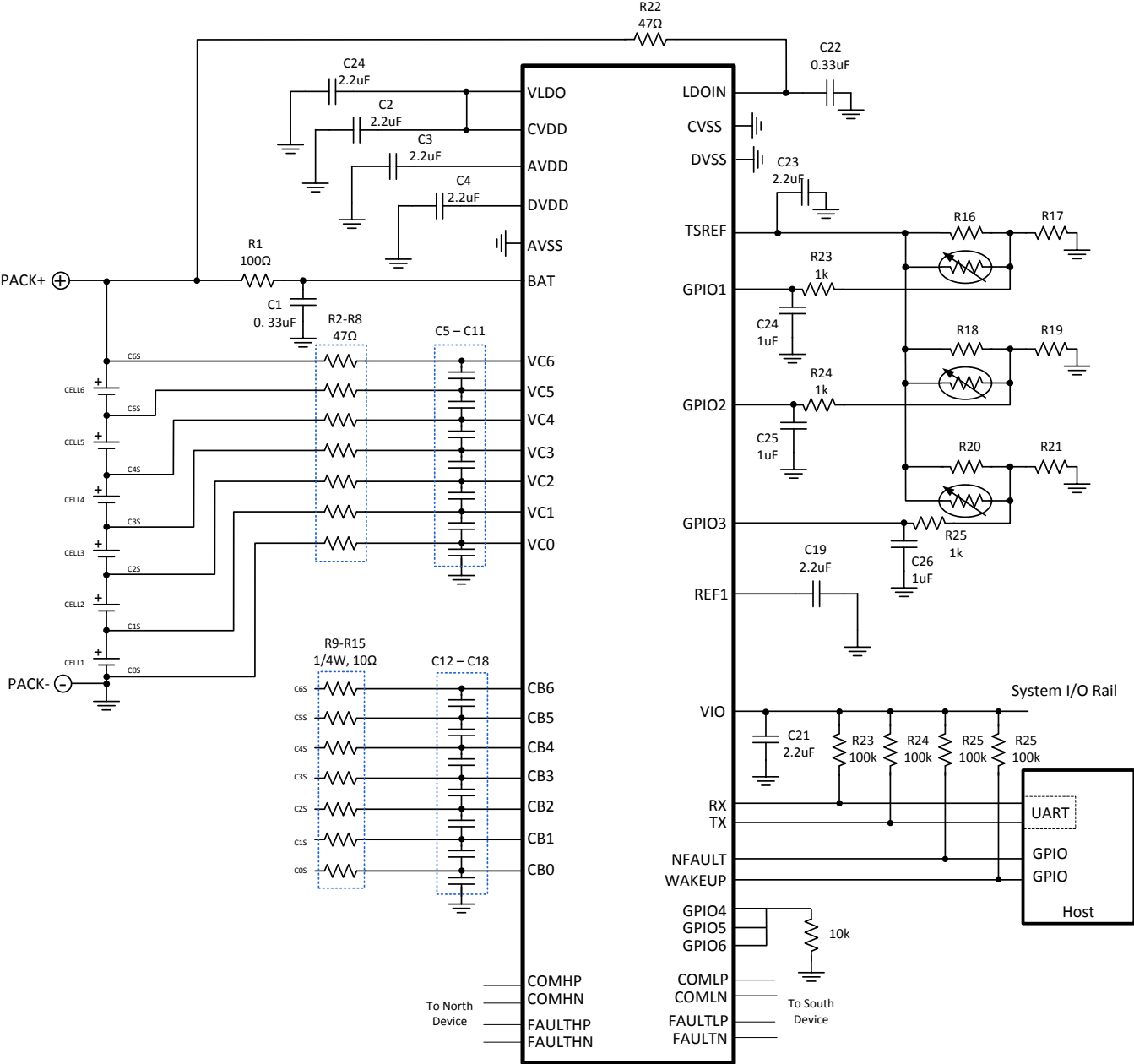

Figure 41. Typical Base Device with Measurement Applications Circuit

9.2.1.1 Design Requirements

Table 34 below shows the design parameters

Table 34. Recommended Design Requirements

Parameter	Value
Module Voltage Range	5.5V to 30V
Number of Cell for each device	3 to 6 cells
VCELL Voltage Range	0V to 5V



## 9.2.1.2 Detailed Design Procedure

### 9.2.1.2.1 LDO Output Bypass

AVDD, VLDO, and DVDD require a decoupling capacitor of no greater than 2.2 $\mu$ F, with minimum temperature stability rating of X7R (COG/NPO provide better performance). C\_VLDO can be as high as 4 $\mu$ F but it will cause slower start up time.

### 9.2.1.2.2 Reference Bypass

REF1 requires a decoupling capacitor of no greater than 2.2 $\mu$ F, with minimum temperature stability rating of X7R (COG/NPO provide better performance).

### 9.2.1.2.3 CVDD and VIO Supply Inputs

Connect CVDD to VLDO through a 0 $\Omega$  resistor (with the exception of Bridge Device of input supply from 4.75V to 5.5V, it must be supplied from an external power supply). Connect VIO to the system rail between 1.8V and 5.25V. VIO is supplied from the system logic supply or is connected to VLDO or CVDD for stack devices (or systems without a logic supply). Both CVDD and VIO require a decoupling capacitor of no greater than 2.2 $\mu$ F, with minimum temperature stability rating of X7R (COG/NPO provide better performance).

### 9.2.1.2.4 BAT Input

The BAT input must include a low-pass filter using a 0.33- $\mu$ F capacitor and a 100 $\Omega$  resistor to avoid voltage stress during cell connection (hot-plug). [Figure 41](#) illustrates the correct VBAT connection. If voltage spikes greater than 36V are expected, connect a transient suppression diode (TVS) to TOP to clamp the voltage to below 36 V to prevent an over-voltage condition on BAT during these events.

### 9.2.1.2.5 LDOIN Supply Input Bypass

The LDOIN input must include a low-pass filter using a 0.33 $\mu$ F capacitor and a 40 $\Omega$  to 50 $\Omega$  resistor to avoid voltage stress during cell connection (hot-plug). [Figure 41](#) illustrates the correct LDOIN connection.

### 9.2.1.2.6 CB Input

The Cell Balancing input are connected to internal balance FET through balancing resistor. The resistor sets the balance current. Connect CBn to VCn if not used. The CB pins must NEVER be connected to cell voltages (module connectors) that are expected to be less than the recommended operating condition. The internal FET diode will conduct and likely damage the FET in reverse voltage conditions. CB0 can not be left floating at any condition.

If a connection to cell1 negative terminal is open the IC bias current will flow through the CB1/VC1 pins and then to the cell2 negative module terminal, causing CB1 and VC1 pins to go below the minimum voltage recommended with respect to pin AVSS. This violates device spec. If the module connector ground pin can float while the other module terminals are still connected it is recommended that a schottky diode be added between CB1 and device GND (AVSS) to ensure that CB1 and VC1 pin voltage does not violate the absolute maximum limits.

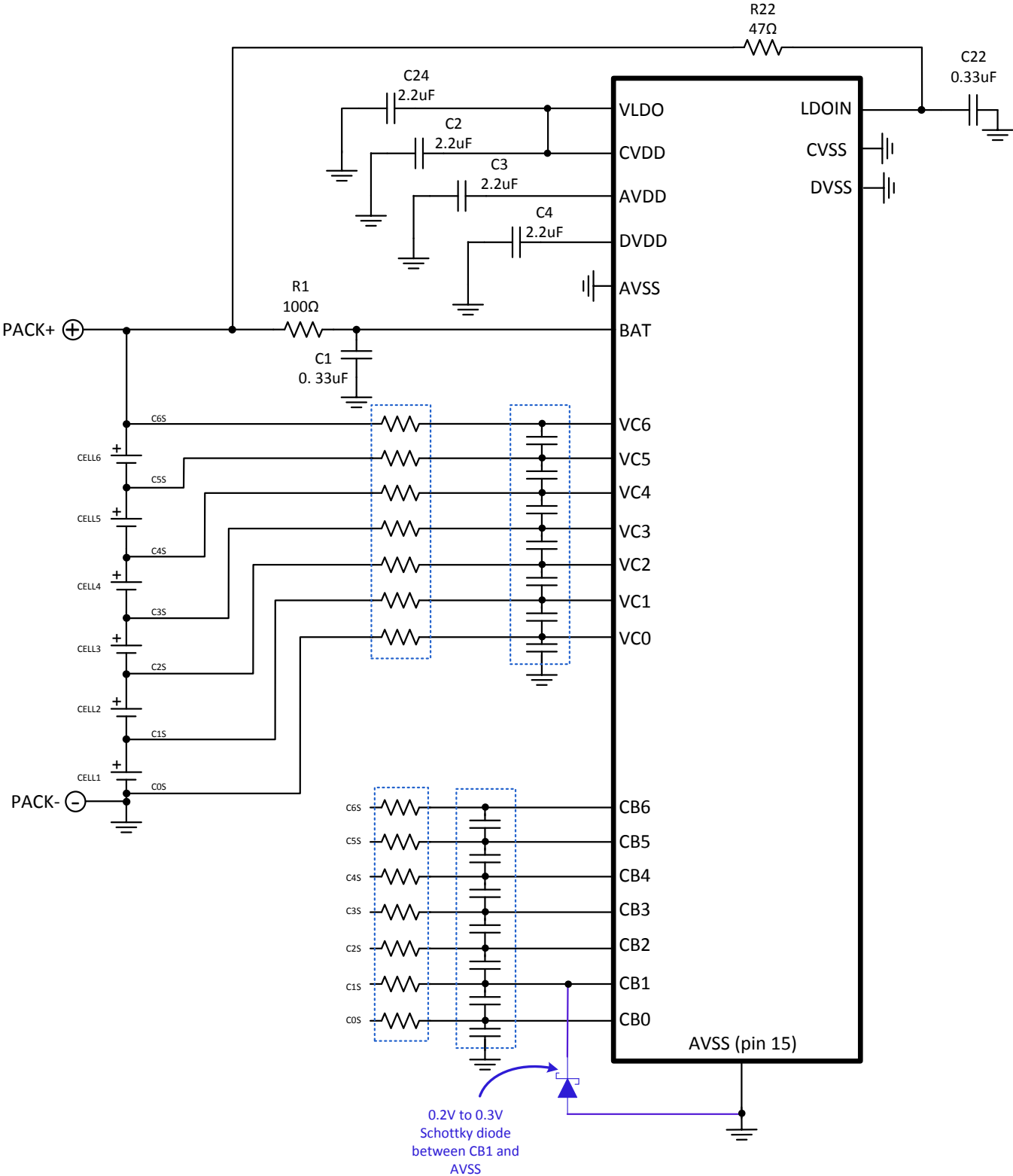

Figure 42. CB Input Connections

### 9.2.1.2.7 VC\* Inputs

While the BQ79606A-Q1 does contain an internal, anti-aliasing RC filter for the cell inputs, many applications experience transient spikes above the absolute maximum rating of the BQ79606A-Q1. For these applications, an additional ESD or a differential RC filter can be connected to reduce voltage spikes that may exceed the absolute maximum voltage ratings. [Figure 43](#) provides a reference for the VC\* input filter. The voltage from VC<sub>n</sub> to VC<sub>n-1</sub> is limited by the cell voltage, see the pin functions table for more details on voltage rating and values. The resistor values are selected based on the values selected for the CB\* (cell balancing) inputs. The values for the VC and CB resistors must be at least 4 times the value of each other in order for the best hot plug performance. Larger values for VC can be always be used, however, the larger the value, the more effect it has on the measurement accuracy. The recommended procedure after the CB resistor is selected, is to select the VC resistor value to be 4 times (recommended to improve SNR and hot pug performance) the value for CB resistor values. See [Selecting Cell Balance Resistors](#) for details on the selecting the cell balance resistor value.

The recommended filter capacitor on VC0 to VC6 listed in [Figure 43](#) (they are different from pin to the other). It is recommended in these combinations for better transient response. If transient response is not a concern, the capacitor valued from 0.47uF to 1uF can be used on all VC pins.

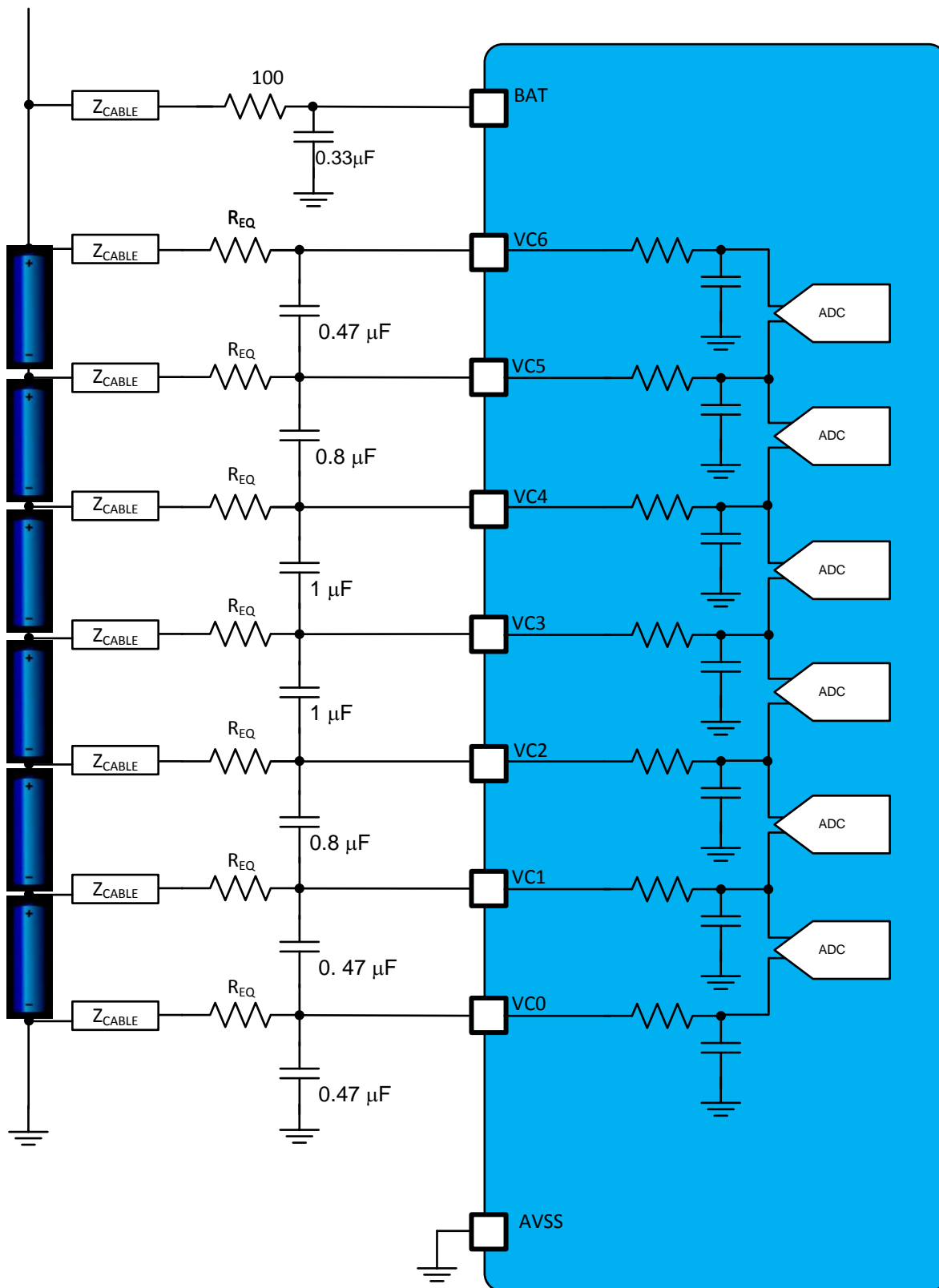

Figure 43. Input Filter Connections

9.2.1.2.7.1 Unused VC Inputs (Modules with less than 6 cells)

The device is capable of operation with 3 to 6 cells. For modules with less than 6 cells, the VC\* inputs must be used in ascending order, with all unused inputs connected together with the input to the highest used VC\* input. For example, in a 4- cells design, inputs VC5, and VC6 are not used. These VC inputs must be connected together with VC4 for proper operation. The same with CB pins. See Figure 44 for an example.

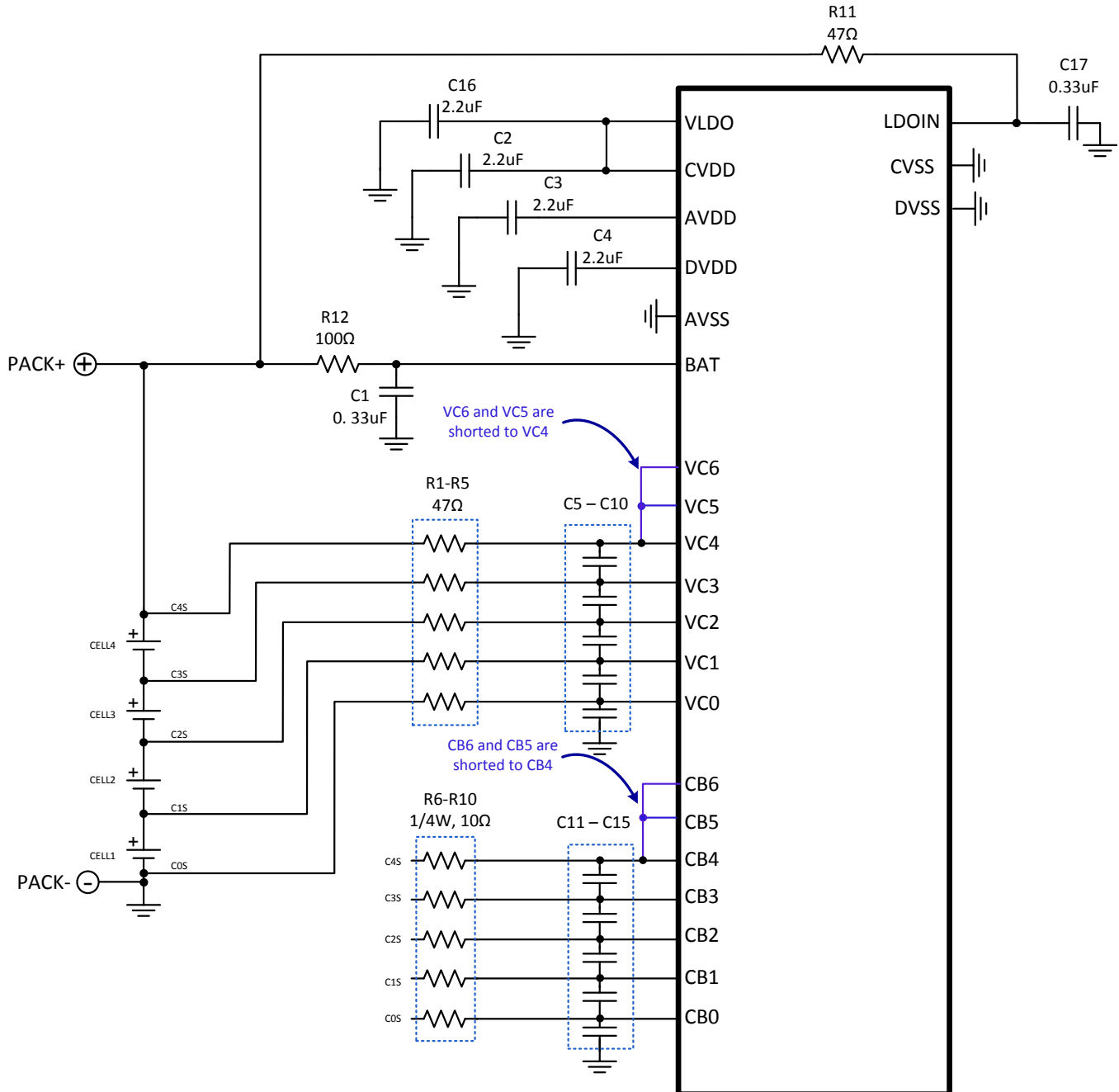

Figure 44. Example of Sense and Power Connections for Sub-6 Cell Application

9.2.1.2.8 GPIO\* Inputs

The GPIO\* inputs are configurable to provide measurement results in ratio-metric form, when measuring an external temperature sensor, or absolute voltage, when measuring an external rail.

9.2.1.2.8.1 Ratiometric Measurement Configuration

When measuring an external temperature sensor, the GPIO connections require a resistor divider from TSREF to AVSS, with the GPIO input connected to the center tap. The NTC is connected from TSREF to GPIO or from GPIO to AVSS, depending on the application requirements. The connections are shown in Figure 45. The resistors linearize the NTC curve to provide the best accuracy over the temperature range of interest.

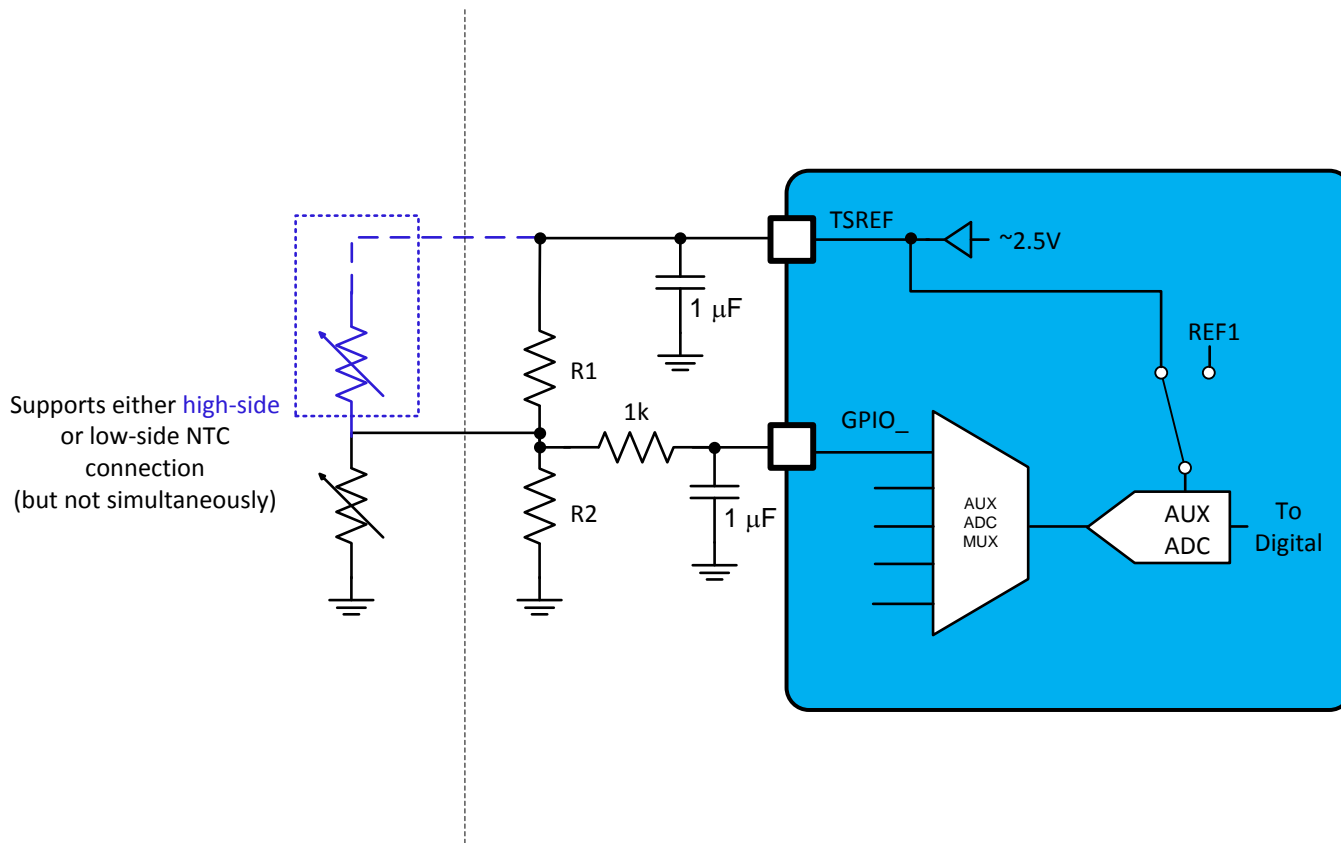

Figure 45. GPIO Ratiometric Measurement

The resistors, R1 and R2, are calculated based on the desired temperature range of interest and the NTC used. For the following calculations, the linearization is highest between 10% and 90% of full scale. First, the temperature range of interest must be selected. This range sets the best resolution (and therefore accuracy) of the temperature sensor. The resistance of the NTC must be calculated for the extremes of this range. Use the following equation to calculate  $R_{HOT}$  (the resistance at the hottest temperature) and  $R_{COLD}$  (the resistance at the coldest temperature):

$$R_{TS} = R_0 \times e^{\beta \times \left( \frac{1}{T} - \frac{1}{25^{\circ}C} \right)} \quad (9)$$

Where  $R_{TS}$  is the calculated NTC resistance,  $R_0$  is the room temperature value of the thermistor,  $\beta$  is the temperature coefficient of the thermistor and  $T$  is the temperature for the calculated resistance.

Once  $R_{HOT}$  and  $R_{COLD}$  are calculated, use the following equations to calculate R1 and R2. For the case where the NTC is connected from GPIO to AVSS, R1 and R2 are calculated using:

$$R_2 = \frac{80 \times R_{HOT} \times R_{COLD}}{R_{COLD} - 81 \times R_{HOT}} \quad (10)$$

$$R_1 = \frac{9 \times R_{HOT} \times R_2}{R_2 + R_{HOT}} \quad (11)$$

For the case where the NTC is connected between TSREF and GPIO, R1 and R2 are calculated using:

$$R_2 = \frac{80 \times R_{HOT} \times R_{COLD}}{9 \times R_{COLD} - 9 \times R_{HOT}} \quad (12)$$

$$R_1 = \frac{9 \times R_{COLD} \times R_2}{R_{COLD} - 9 \times R_2} \quad (13)$$

Additionally, connect a 1- kΩ resistor from the center tap of the resistor divider to the GPIO input ( GPIO pin used as input to AUX ADC to measure the temperature) and bypass VGPIO to AVSS with a 1-μF capacitor.

When the NTC is connected from GPIO to AVSS the temperature of the sensor is calculated as:

$$Temp = \frac{1}{\frac{\ln\left(\frac{R1 \times R2 \times \text{RATIO\_ADC}}{R0 \times (R1 \times \text{RATIO\_ADC} - R2 \times (1 - \text{RATIO\_ADC}))}\right)}{\beta} + \frac{1}{25}} \quad (14)$$

When the NTC is connected from TSREF to GPIO the temperature of the sensor is calculated as:

$$Temp = \frac{1}{\frac{\ln\left(\frac{R1 \times R2 \times (1 - \text{RATIO\_ADC})}{R0 \times (R1 \times \text{RATIO\_ADC} - R2 \times (1 - \text{RATIO\_ADC}))}\right)}{\beta} + \frac{1}{25}} \quad (15)$$

Where RATIO\_ADC is the result of [Equation 3](#), R1 and R2 are the linearization resistor values, R0 is the NTC value at room temperature (25C), and β is the temperature coefficient of the NTC.

When measuring a voltage, these channels require a simple external low-pass filter to reduce high frequency noise for best operation. The RC values correspond to the customer's application requirements.

#### 9.2.1.2.8.2 Absolute Measurement Configuration

When measuring a voltage, GPIO\* connections require a series resistor and bypass capacitor for filtering to ensure best results. See [Figure 46](#) for connection example.

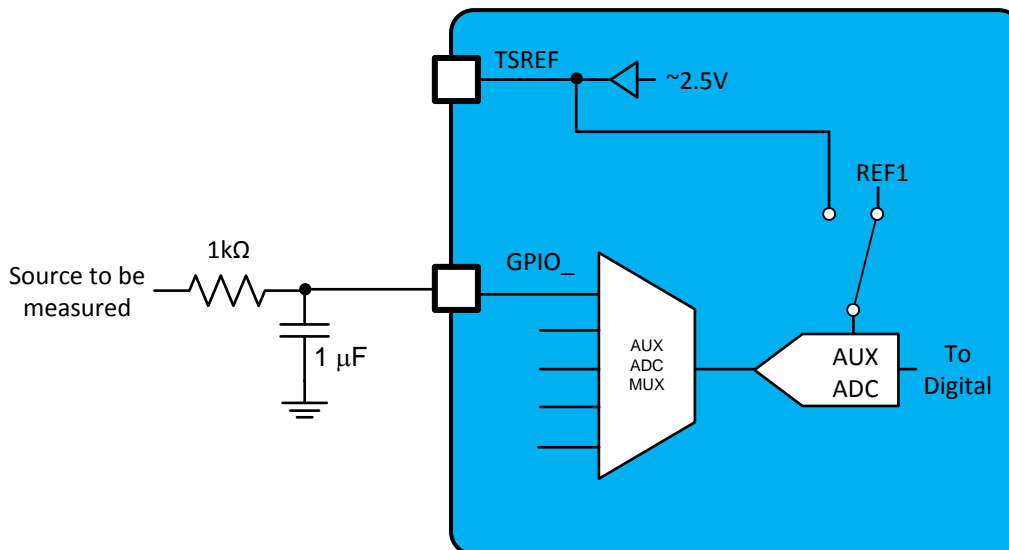

Figure 46. GPIO Voltage Measurement

9.2.1.2.8.3 Unused GPIO\* Inputs

Connect GPIO\* to AVSS through a 10-kΩ resistor if unused.

9.2.1.2.9 UART Communication Bus

The UART interface requires that TX and RX are pulled-up to VIO through a 10-kΩ to 100-kΩ resistor. Do not leave TX and RX unconnected. The TX must be pulled high to prevent triggering an invalid communications frame during the idle state when TX is high. When using a serial cable to connect to the host controller, connect the TX pull up on the host side and the RX pull up on the BQ79606A-Q1 side.

9.2.1.2.10 Daisy-Chain Differential Bus

9.2.1.2.10.1 Devices on Same PCB

For applications where multiple BQ79606A-Q1 IC's are daisy chained on the same board, a single level-shifting capacitor is connected between the COM\_ and FAULT\_ pins of the devices. The capacitor value is 1000pF to 2500pF (2200pF typical) with a voltage rating of at least two times the total stack of cells voltage (for 400V system a 800V is required). In a case of the devices are not on the same PCB. The level shifting capacitors should be connected on both sides as shown below:

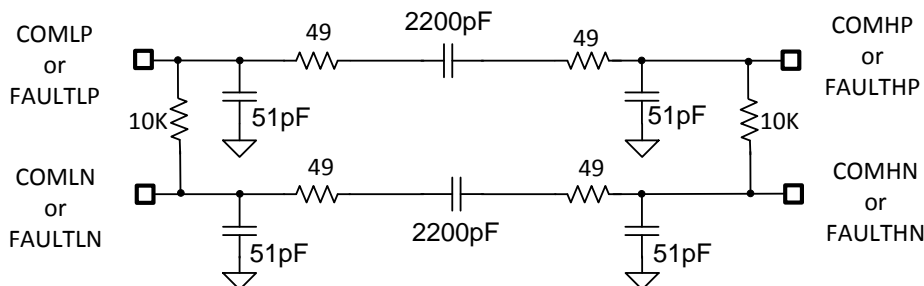

Components Required for Capacitive Coupled Daisy Chain in the same PCB

Figure 47. Connections for Stacked Devices on the Same PCB



**9.2.1.2.10.2 Devices Separated by Cabling (Not on the Same PCB)**

Many applications require multiple, daisy-chained BQ79606A-Q1 devices that are separated by cables. The cable introduces additional challenges to the application. To provide proper isolation for these applications, the BQ79606A-Q1 supports both transformer and capacitor isolation.

**9.2.1.2.10.2.1 Capacitor Isolation (Not the same PCB)**

The drivers and protocol for the BQ79606A-Q1 is suitable to drive transformer and capacitor isolation for the daisy chain communication. The following sections detail the implementation for capacitor isolation. Note that both types of isolation are possible in a system, with no differences in the setup of each device. For example, it is possible to use transformer isolation between the low-voltage and high-voltage boundary for galvanic isolation, while using capacitor isolation between modules in the stack. The figure below shows capacitive isolation with and without choke. The choke adds additional robustness during BCI noise and long cable applications. With the capacitor plus choke, a 300mA BCI noise can easily be achieved. For capacitive only isolation, up to 200mA BCI with 1.7m cable can be achieved.

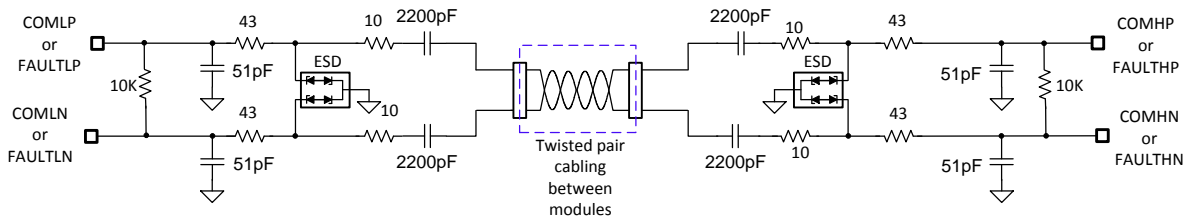

**A. Components Required for Capacitive Coupled Daisy Chain with Cabling (200mA BCI)**

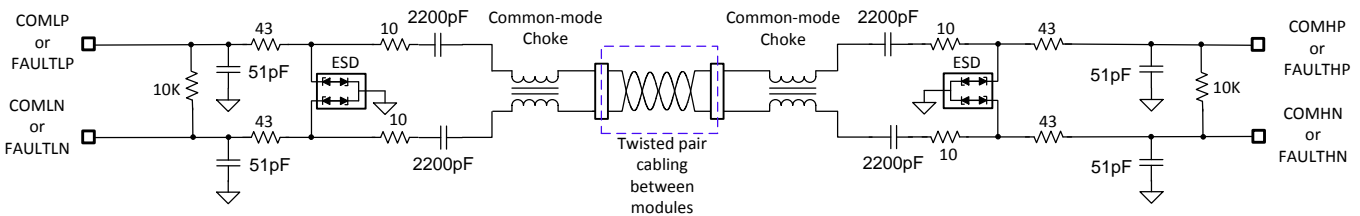

**B. Components Required for Capacitive+ Choke Coupled Daisy Chain with Cabling (300mA BCI)**

**Figure 48. Capacitor Isolation Circuit**

**Isolation Capacitor**

The differential signal lines are isolated between ICs by a DC blocking capacitor. The capacitor must be rated with a high enough voltage to provide standoff margin in the event of a fault in the system that exposes the device to a local hazardous voltage. Selecting a capacitor rated at a minimum of two times the stack voltage is the recommended practice. Ideally, only one 1000pF to 2500pF (2200pF typical) capacitor is sufficient for the normal operation of the device. However, two capacitors may be used (one at each end of the cable or PCB wiring) for an additional safety factor and proper coupling on both sides of the cable.

The capacitance on the daisy chain bus has a direct effect on performance. All parasitic capacitances from the support components and cabling must be taken into consideration when designing for communication robustness to EMC. Capacitance from the cables, ESD diodes, bypass capacitance, and chokes, form a capacitive divider with the isolation capacitors that may affect performance. Additionally, the amount of capacitance on the bus has a direct impact to the operating current during communication (the capacitor charging/ discharging).

## Common-Mode Filter

While not required for cable lengths less than 2m and BCI performance of less than 200mA, longer cable lengths, or abnormally noisy applications may require the use of a common-mode choke filter. Capacitive isolation plus choke has better noise immunity than capacitor only. For 1.7m cable and according to ISO 11452-4 BCI spec, the capacitor only isolation can pass up to 200mA BCI noise and if a choke is added, a 300mA BCI noise can be handled. For these applications, use an automotive grade from 100uH to 500 μH common-mode filter minimum for proper operation. To achieve the best performance in noisy environments, use dual common-mode filters (470 μH). The recommended impedance of the choke is at least 1KΩ from 1MHz to 100MHz and above 300Ω for higher frequencies

### 9.2.1.2.10.2.2 Transformer Isolation

The drivers and protocol for the BQ79606A-Q1 is suitable to drive transformer and capacitor isolation for the daisy chain communication. The following sections detail the implementation for transformer isolation. Note that both types of isolation are possible in a system, with no differences in the setup of each device. For example, it is possible to use transformer isolation between the low-voltage and high-voltage boundary for galvanic isolation, while using capacitor isolation between modules in the stack. If transformer isolation is used, a 1KΩ termination resistor is required between the COM P and COM N

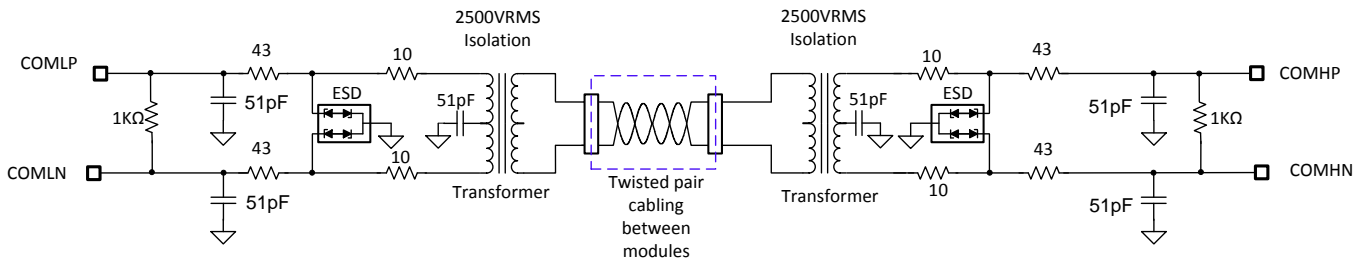

Figure 49. Transformer Isolation Circuit

## Transformer Specifications

The BQ79606A-Q1 has been designed and tested with transformers ranging from 150uH to 650uH. The recommended parameters for the isolation transformer are as follows:

- Inductance: 150uH to 650μH
- Leakage Inductance: ~20μH
- Automotive rated
- Operating Temperature: -40C to 125C
- Isolation voltage: Depends on total stack voltage (example 2500V AC, 1000V DC for an 400V system) .

### 9.2.1.2.10.2.3 Daisy-Chain Cables

When selecting the cabling, keep in mind that the cable adds parasitics to the system. For capacitively isolated systems, the capacitance of the cable forms a divider with the isolation capacitance. See the [Capacitor Isolation \(Not the same PCB\)](#) section for details. The capacitance of the cable is calculated using the equation:

$$C = \frac{2.2\epsilon}{\text{Log}\left(\frac{1.3 D}{f \times d}\right)} \quad (16)$$

where

- C = mutual capacitance , pF/ft
- ε = insulation dielectric constant (for example: PVC = 5)
- f = stranding factor (for example: 1 strand = 1, 7 strands = 0.939, 19 strands = 0.97, 37 strands = 0.98)
- D = diameter over the insulation, inches
- d = diameter of the conductor, inches (12)

The unshielded twisted cable used for bench testing (Alpha Wire 3050 series, Digi-Key part number +A2015W-1000-ND) has the following specifications:

- $\epsilon = 5$  (PVC)
- $f = 0.939$  (7 strand)
- $D = 0.056''$
- $d = 0.024''$  ( $0.056'' - 2 \times 0.016''$  insulation thickness)
- conductor DCR =  $25 \Omega/1000$  ft

The resulting capacitance is  $\approx 21.6$  pF/ft.

The best choice of differential cable is an automotive-grade, unshielded, twisted cable designed for CAN, such as the Waytek SAE J1939/15 CAN data bus cable. The capacitance for this cable is approximately 17 pF/ft.

### 9.2.1.2.10.3 Daisy Chain System Components

#### 9.2.1.2.10.3.1 Series Termination Resistance

Select the series termination resistors for each COML\_, COMH\_, FAULTL\_, or FAULTH\_ lines between devices to be  $120 \Omega$  ( $\sim 50 \Omega$  on each end of the signal connection between BQ79606A-Q1 devices plus the  $10 \Omega$  internal resistance). This series resistance also limits the in-rush current during a service disconnect/reconnect event.

#### 9.2.1.2.10.3.2 Bypass Capacitance

Select the bypass capacitors for each COML\_, COMH\_, FAULTL\_, or FAULTH\_ lines between devices to be 51pF. This bypass capacitance provides filtering as well as improved performance during BCI testing.

#### 9.2.1.2.10.3.3 Daisy Chain System ESD Protection

The common-mode range for the BQ79606A-Q1 is suitable for common ESD protection diodes used for CAN applications. The ESD protector should provide protection to the communication interface pins during hot plug events and also for absorption of high-voltage transients during service disconnect/reconnect. Select the ESD diodes to limit the maximum voltage on the COM\* or the FAULT\* bus to below the maximum rating. A voltage rating close the maximum voltage to provide the highest possible common-mode voltage range is recommended for best EMC performance. The capacitance must be low compared to the coupling capacitance (if using capacitor coupling).

#### 9.2.1.2.10.4 Unused Differential Communications Pins

Unused stack communications pins (COML\_, COMH\_, FAULTL\_, or FAULTH\_) have internal terminations; no external pull up or pull down resistors are required on these pins. If not used, leave the unused pins unconnected. The daisy chain transmitter and receiver enable/ disable control is found in the DAISY\_CHAIN\_CTRL register.

### 9.2.1.2.11 Cell Balancing

#### 9.2.1.2.11.1 Selecting Cell Balance Resistors

The cell balancing current,  $I_{EQ}$ , is set using the resistors,  $R_{EQ}$ . All cell balancing resistors must be the same value. The value for  $R_{EQ}$  is calculated as:

$$R_{EQ} = \frac{1}{2} \times \left( \frac{V_{BAT}}{I_{EQ}} - R_{DS(ON)} \right) \quad (17)$$

#### 9.2.1.2.11.2 Differential Filter Capacitor Selection

Connect a 0.47 $\mu$ F to 1 $\mu$ F, 10V capacitor between CBn and CBn-1 to filter out high voltage, high frequency voltage transients that may exceed the absolute maximum rating for the CB voltage.

#### 9.2.1.2.11.3 Cell Balancing External MOSFET Selection (optional)

For applications that require more balancing current, the BQ79606A-Q1 supports external FETs. Select the Balance FET based on the following criteria:

1. The VDS must be selected based on derating requirements determined by the stack voltage.
2. The VGS threshold must be low enough to turn on with the lowest battery voltage planned for balancing. The

gate of the MOSFET sees half of the battery voltage, so the VGS of the MOSFET must be selected to provide sufficiently low RDSON at half of the lowest battery voltage.

$R_{DSON}$  is not a major concern, but must be taken into account when choosing the resistors. Power dissipation of the FET is a function of discharge current selected and the resistance value of FET at that worst-case condition, usually at hot temperature.  $I^2R$  calculates the power dissipated. Take care in selecting size if using very small packages. A series resistor between the CB pin and the FET gate limits current going into the FET during hot plug or other transient events. The VGS capacitor ensures the FET is not turned on during hotplug due to the miller capacitance of the FET. Also note that P and N FET combination can be used.

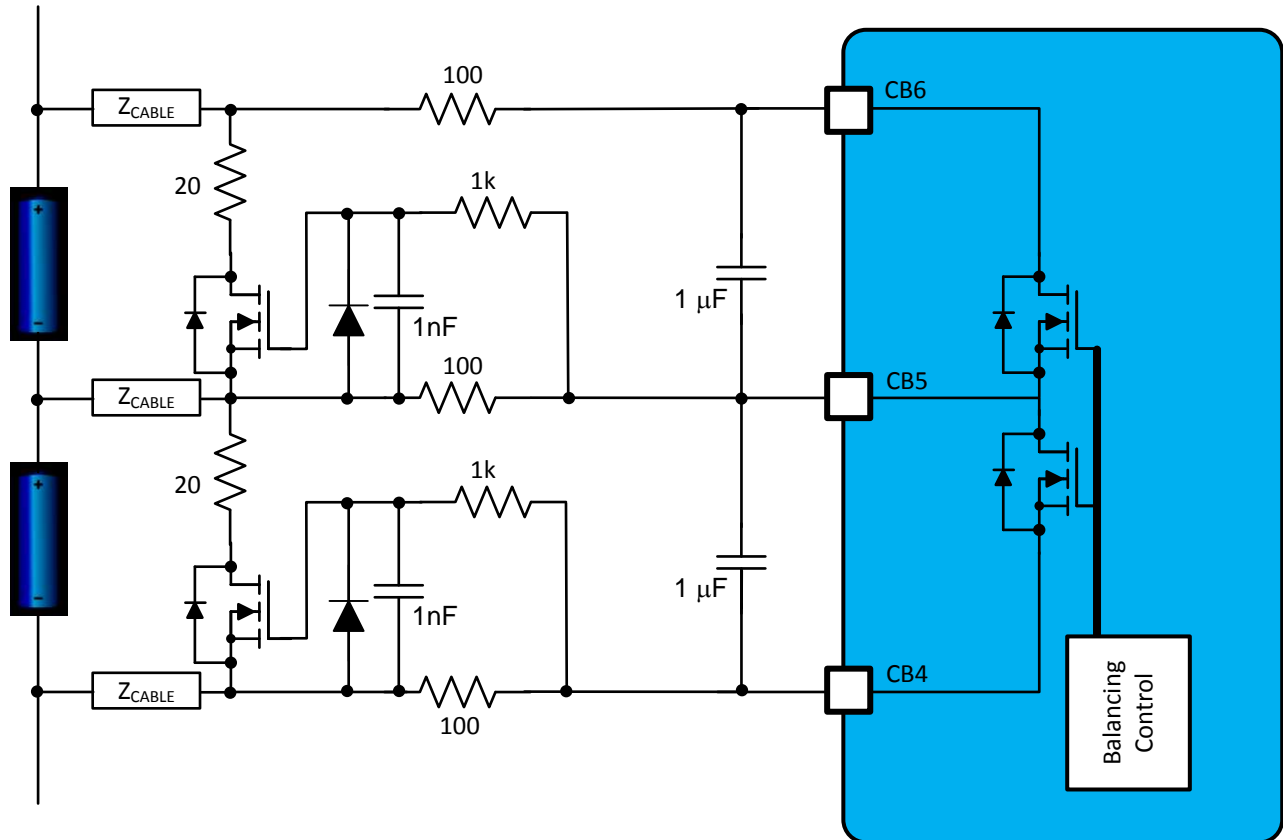

Figure 50. Cell Balancing Circuit with External MOSFETs

#### 9.2.1.2.12 Post-Assembly Calibration

##### 9.2.1.2.12.1 Cell ADC Post-Assembly Calibration

Use of post-assembly calibration adjustment can improve device accuracy further after exposure to soldering and/or bake cycles in the manufacturing process. ADC gain and offset-correction factors are programmable for each cell in the BQ79606A-Q1 to allow for post-assembly calibration. The total range of adjustment limitation for the gain factor is -19.4mV to 19.4mV and the offset factor is -24.2mV to 24.2mV. Application of the corrections is to the raw ADC values after application of the factory stored offset and gain corrections. Perform the correction procedures at room temperature (RT) using a stable, high-accuracy DC source and / or voltmeter. The registers contain signed 2's complement values. A zero value in either register indicates no correction. Measurement of two voltage points, VIN1 and VIN2, occurs for each correction. The expected minimum and maximum values for the cell can be used.

##### 9.2.1.2.12.1.1 Gain Error Correction

Gain Error Correction: For a 5V cell voltage, -19.4 mV to 19.4 mV in 255 steps (8 bits) in the CELL\*\_GAIN registers (one per channel) Procedure:

1. Set the CELL ADC to 1MHz frequency, 256 Decimation Ratio, Corner frequency to 1.2 Hz for best results.

2. Apply voltage VIN1, read back from ADC VOUT1 in the VCELL\*\_LF, VCELL\*\_HF registers, and record both.
3. Apply voltage VIN2, read back from ADC VOUT2 in the VCELL\*\_LF, VCELL\*\_HF registers, and record both.
4. Find the gain error correction (GEC) at 5 V (5V is used regardless of VINx value) and write the 8-bit value to the CELL\*\_GAIN register.
  1. Calculate slope  $m = (VOUT2 - VOUT1) / (VIN2 - VIN1)$
  2. The gain error is calculated at 5V. Thus Gain Error =  $[(5V * m) - 5V]$
  3. The Gain Shift value is  $19.4mV^2 / 255 = 0.15mV$
  4. Then take the negative of the gain and divide it by the gain shift to find bit shift required Bit Shift =  $(-Gain Error) / (Gain Shift)$
  5. Then convert bit shift to a two's complement hex value
  6. Make sure that if the bit shift is greater than "127", the hex value will be "7F"
  7. Make sure that if the bit shift is less than "-128", the hex value will be "80"
  8. Finally enter the calculated Hex value to CELL\*\_Gain
5. Repeat steps 1-3 on each cell voltage
6. Perform the steps in Offset Error Correction.

#### 9.2.1.2.12.1.2 Offset Error Correction

Offset Error Correction: -24.2 mV to +24.2 mV in 255 steps (8 bits) in the CELL\*\_OFF registers (one per channel) Procedure: (Use recorded, VIN1, and VOUT1 from the Gain Error Correction procedure.)

1. Find the offset value based on the VIN1 value, Offset =  $(VIN1 - VOUT1) / (190.7348uV)$
2. Convert to a two's complement hex
3. Make sure that if the offset is greater than "127", the hex value will be "7F"
4. Make sure that if the offset is less than "-128", the hex value will be "80"
5. Write the 8-bit value to the CELL\*\_OFF register
6. Repeat steps 1-5 on each cell voltage
7. Save the new values to OTP by following the NVM programming procedure.
8. The OTP CRC must be re-calculation and saved due to this (or any) change.

#### 9.2.1.2.12.2 GPIO\* Post-Assembly Calibration

Using post-assembly calibration adjustment can also improve the GPIO channel accuracy further after exposure to soldering and/or bake cycles in the manufacturing process. The process is the same as the steps for the VC\* channel correction. Perform the correction procedures at room temperature (RT) using a stable, high-accuracy DC source and / or voltmeter. The registers contain 10-bit, signed, 2's-complement values. A zero value in any register indicates no correction. Each correction measures two voltage points. The procedure can use the expected minimum and maximum values for the cell. The gain values are updated in the GPIO\*\_GAIN registers and the offset values are updated in the GPIO\*\_OFF registers.

#### 9.2.1.2.13 Device Addressing

Every device must have a unique address for the read functionality to work. If, for any reason, two devices are assigned with the same address, it is likely that broadcast and stack reads do not work. Additionally, reads to the doubled address result in destroyed communication. Care must be taken to assign independent address for every device. There are three ways to address the device: using NVM burn on the DEVADD\_OTP[ADD], using auto-addressing, and using GPIO addressing.

##### 9.2.1.2.13.1 NVM Stored Address

The user can program the device address on the DEVADD\_OTP register. As part of the reset process, the OTP restores the value in DEVADD\_OTP[ADD]. This address is saved in the OTP as part of the NVM burn.

### 9.2.1.2.13.2 Auto Addressing

Prior to using the Auto-Addressing function in a stack, all devices must be awake and ready for communication. The steps necessary for this state are detailed elsewhere in this document, but typically require a few milliseconds per device ( $t_{SU(WAKE)}$ ). Very simple "stacks" consisting of a single device may use address 0x00 (or any other valid address) for the device. The first device in stacks of more than one device may also use Address 0x00.

When `CONFIG[GPIO_ADD_SEL] = 0` and `CONTROL1[ADD_WRITE_EN]` is set, the device enters automatic addressing mode. In this mode, the device turns off the daisy-chain transmitters for one frame (so the next frame received is not propagated to the next device) and enables writes to `DEVADD_USR[ADD]`. The next frame sent must set the address. Once the next frame is received (this frame must be the address or it will save the address currently in the register), the `CONTROL1[ADD_WRITE_EN]` bit is self cleared and the address is not writeable. Additionally, the result is reflected in the `DEV_ADD_STAT[ADD]` bits indicating the address is updated. At this time, the user may write to the `DEVADD_OTP[ADD]` bits to save the address, or the addressing may be done as part of the initialization process. When the `CONTROL1[ADD_WRITE_EN]` bit is self cleared, the transmitter is turned on. This allows the host to use a Broadcast write transaction and only affect the one part waiting for an address. To auto-address the stack of BQ79606A-Q1 devices, use the following procedure (assumes `CONFIG[GPIO_ADD_SEL] = 0` in the OTP):

1. Broadcast write `CONTROL1[ADD_WRITE_EN] = 1`
2. Broadcast write consecutive addresses to `DEVADD_USR[ADD]` until all parts have been assigned a valid address.
3. Single device write "0x00" to the base device to set the as BASE device in the `CONFIG[STACK_DEV]` register bit.
4. Single device write "0x02" to to all devices except the top and bottom of stack to set them as stack devices in the `CONFIG[STACK_DEV]` register bit..
5. Single device write "0x03" to the top device in the stack to set the `CONFIG[TOP_STACK]` bit and update the CRC for that device

Good practice dictates that all devices be checked by reading back their address registers, at a minimum, to establish that the addressing functions worked properly. Subsequent reading and writing depend on correctly addressed devices in the stack or executing any customer-initiated tests, such as the checksum test.

### 9.2.1.2.13.3 GPIO Addressing

Prior to using the GPIO addressing function in a stack, all devices must be awake and ready for communication. The steps necessary for this state are detailed elsewhere in this document, but typically require a few milliseconds per device. Very simple "stacks" consisting of a single device may use address 0x00 (or any other valid address) for the device. The first device in stacks of more than one device may also use address 0x00. GPIO1 to GPIO6 are programmable to be addressing inputs using the `GPIO*_CONF[ADD_SEL]` bit. When fewer stack devices are used, fewer GPIOs are required for addressing. For example, if 10 device address are required, only GPIO1 through GPIO4 are required for addressing. The additional GPIOs are still available for the additional functionality. The GPIO number corresponds to the bit number in the `DEV_ADD_STAT` register (i.e. GPIO2 is bit 2). The GPIO is automatically setup as input when addressing is enabled (`GPIO*_CONF[ADD_SEL]=1`). `GPIO*_CONF[GPIO_SEL]` bit is ignored.

When `CONFIG[GPIO_ADD_SEL] = 1` and `CONTROL1[ADD_WRITE_EN]` is set, the device enters GPIO addressing mode. In this mode, the device samples the enabled GPIO and updates the `DEV_ADD_STAT[ADD]` bits. Any GPIOs that do not have GPIO addressing mode enabled are read as '0'. At this time, the user may write to the `DEVADD_OTP[ADD]` bits to save the address, or the addressing may be done as part of the initialization process. Once the address is updated, the `CONTROL1[ADD_WRITE_EN]` bit is self cleared and the address is not writeable. It should be noted that once the GPIOs are used for the addressing, they may be reconfigured to be used in a different function without affecting the addressing. To GPIO-address the stack of BQ79606A-Q1 devices, use the following procedure

1. Configure the addressing GPIOs in hardware to the required address. The addressing must be sequential from the first to the last device
2. Broadcast write to the `GPIO*_CONF[ADD_SEL]` bits to enable the required addressing GPIOs
3. Broadcast write `CONFIG[GPIO_ADD_SEL] = 1` (if not already set by OTP default)
4. Broadcast write `CONTROL1[ADD_WRITE_EN] = 1`



5. Set the CONFIG[STACK\_DEV] register bit as base for base device and as stack for stack devices.
6. Single device write to the top device in the stack to set the CONFIG[TOP\_STACK] bit and update CRC for that device

Good practice dictates that all devices be checked by reading back their address registers, at a minimum, to establish that the addressing functions worked properly. Subsequent reading and writing depend on correctly addressed devices in the stack or executing any user-initiated tests.

### 9.2.1.2.14 Calculating Wakeup Timing

#### 9.2.1.2.14.1 Wakeup Timing in SHUTDOWN Mode (or Initial Powerup)

When power is applied to the IC, the internal analog supply AVAO\_REF is turned on. After AVAO\_REF is turned on, the IC transitions to SHUTDOWN mode. The VLDO turn ON after  $t_{PORtoWKRDY}$ . Once that happened, the device is ready for communication. The wake up process is as follows:

1. The host microcontroller pulses the WAKEUP input on the base device to initiate the wakeup sequence
2. IC enables the AVDD and DVDD LDOs as well as all of the required references and enters ACTIVE mode.
3. The IC sends a WAKE tone to the next device in the stack. The WAKE tone is received in  $n_{WAKEDET} * t_{COMTONE}$
4. The next IC repeats steps 2 and 3.
5. The process repeats until all devices transition to ACTIVE mode.

The total time to transition a full stack from POR to ACTIVE is calculated as:  $n_{devices} * t_{SU(WAKE)}$

The total time to transition a full stack from SHUTDOWN to ACTIVE is calculated as:  $n_{devices} * t_{SU(WAKE)}$

#### 9.2.1.2.14.2 Wakeup Timing in SLEEP Mode

There are two methods to transition the stack from SLEEP mode to ACTIVE mode. The first method is to send a WAKE command. This resets the entire stack to the OTP defaults. The second is to send a SLEEPtoACTIVE command. This command only transitions the device to ACTIVE mode and does NOT reset the register content.

##### 9.2.1.2.14.2.1 Wake Up Command

When sending a WAKE command, the process is as follows:

1. The host microcontroller pulses the WAKEUP input on the base device to initiate the wakeup sequence
2. IC enters ACTIVE mode and loads the registers with the default values from OTP. This transition takes  $t_{SU(SLPtoACT)2}$
3. The IC sends a WAKE tone to the next device in the stack. The WAKE tone is received in  $n_{WAKEDET} * t_{COMTONE}$
4. The next IC repeats steps 2 and 3.
5. The process repeats until all devices transition to ACTIVE mode.

##### 9.2.1.2.14.2.2 SLEEPtoACTIVE command

When sending a SLEEPtoACTIVE command, the process is as follows:

1. The host microcontroller holds the RX input low ( $t_{UART(SIA)}$ ) on the base device to initiate the sleep to active sequence
2. IC enters ACTIVE mode. This transition takes  $t_{SU(SLPtoACT)1}$
3. The IC sends a SLEEPtoACTIVE tone to the next device in the stack. The SLEEPtoACTIVE tone is received in  $n_{SLPtoACTDET} * t_{COMTONE}$
4. The next IC repeats steps 2 and 3.
5. The process repeats until all devices transition to ACTIVE mode.

The total time to transition a full stack from SLEEP to ACTIVE with a SLEEPtoACTIVE command is calculated as:  $t_{UART(SIA)} + n_{devices} * t_{SU(SLPtoACT)1} + (n_{devices}-1) * n_{SLPtoACTDET} * t_{COMTONE}$

The total time to transition a full stack from SLEEP to ACTIVE with a WAKE command is calculated as:  $2 * t_{HLD\_WAKE} + n_{devices} * t_{SU(SLPtoACT)2} + (n_{devices}-1) * n_{WAKEDET} * t_{COMTONE}$

### 9.2.1.3 Application Curves

The plots below shows the wake up timing of 17 devices. One device is used as a base and 16 devices as stack. The WAKEUP pin of the base device is hold low for approximately 270us and base send wake up tone upstream. The wake up tone is  $t_{COMTONE}$  long. SLEEP to ACTIVE tone sending is 40 tones at max. The experiment below show 4.4ms time for each device to wake up. It took total of 75ms for 17 devices to wake up.

**Channel 1:** WAKEUP pin of the base device. **Channel 2:** COML\* pin of the device 16. **Channel 3:** COML\* pin of the device 15. **Channel 4:** AVDD pin of device 16.



Figure 51. Time Between Pulses

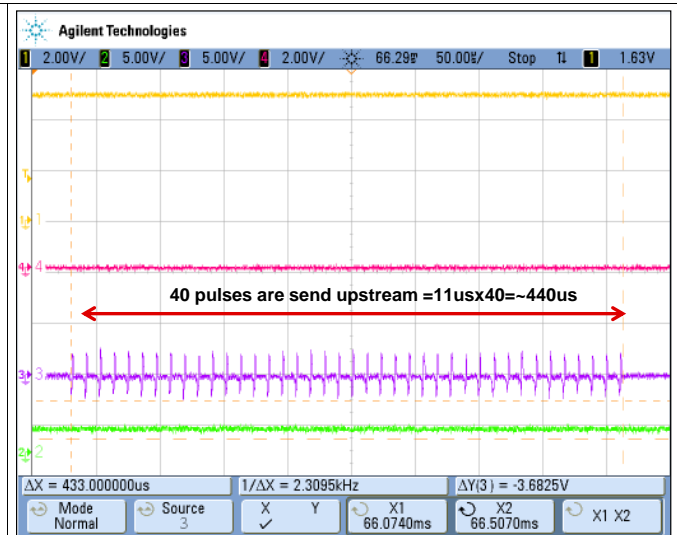

Figure 52. Number of Pulses

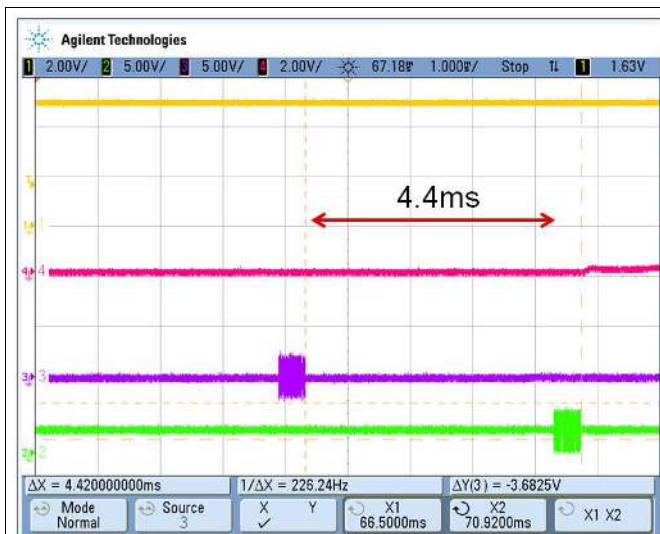

Figure 53. The Time Between 40 Pulses Send From Stack Device to Another

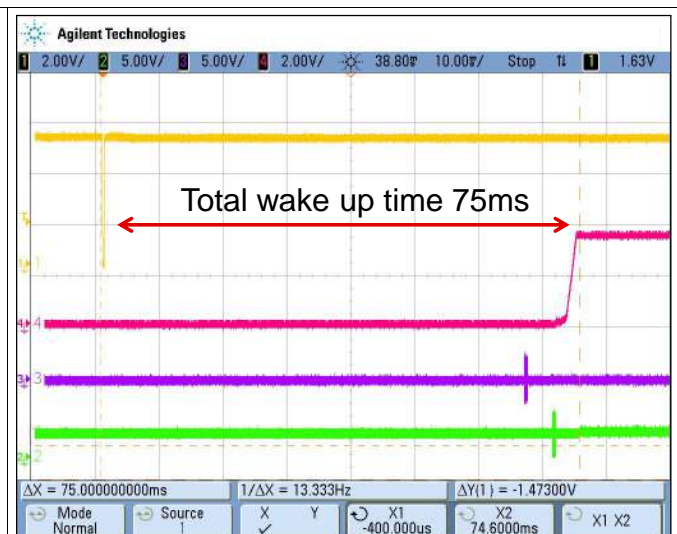

Figure 54. Total Wake Up Time of 17 Devices

### 9.2.2 Bridge Mode

The BQ79606A-Q1 supports low voltage operation from a 4.75V power supply, such as a CAN power supply when used as bridge device. For this application, the some of the power supplies for the device must be powered by the external supply for best operational results. Connect CVDD supply directly to the input supply. Note that in this configuration, the power supply range is limited to 4.75V to 5.5V.



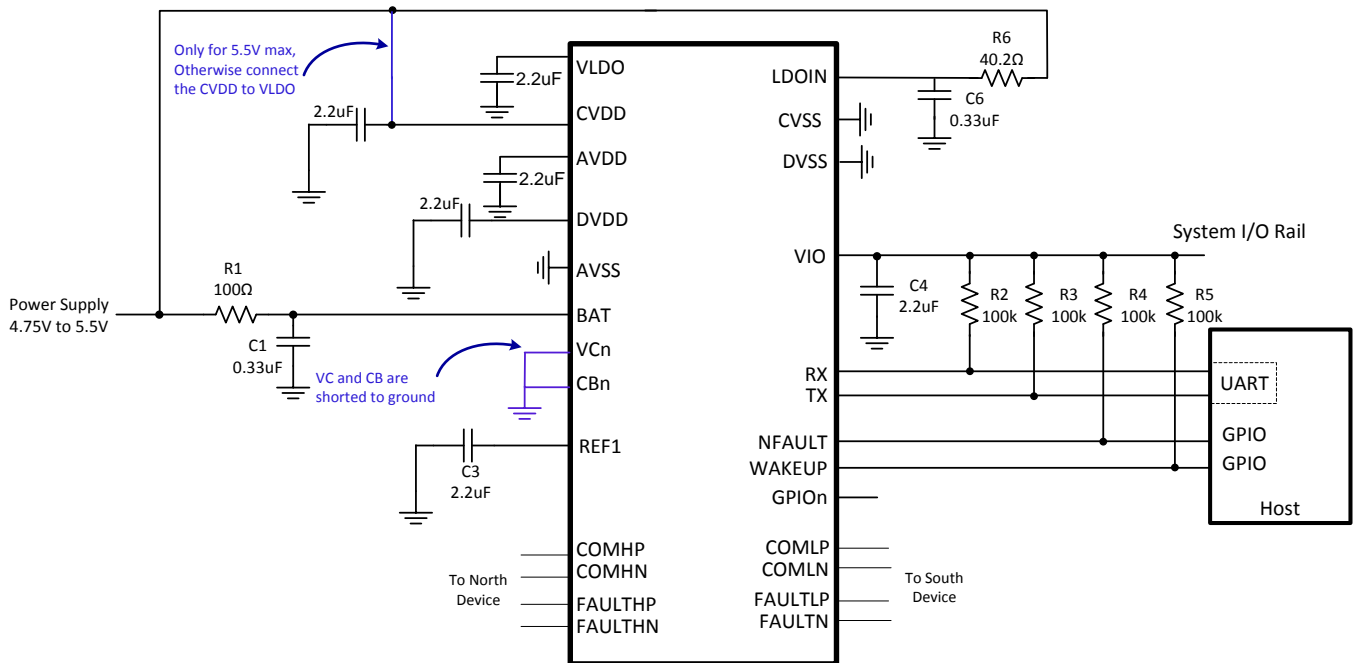

Figure 55. Typical Application Circuit for Bridge Device for Input Supply From 4.75V to 5.5V

The BQ79606A-Q1 also supports high voltage operation from a 5.5V power supply to 30V. For such application, the CVDD must connect to VLDO (NOT from VLDOIN).

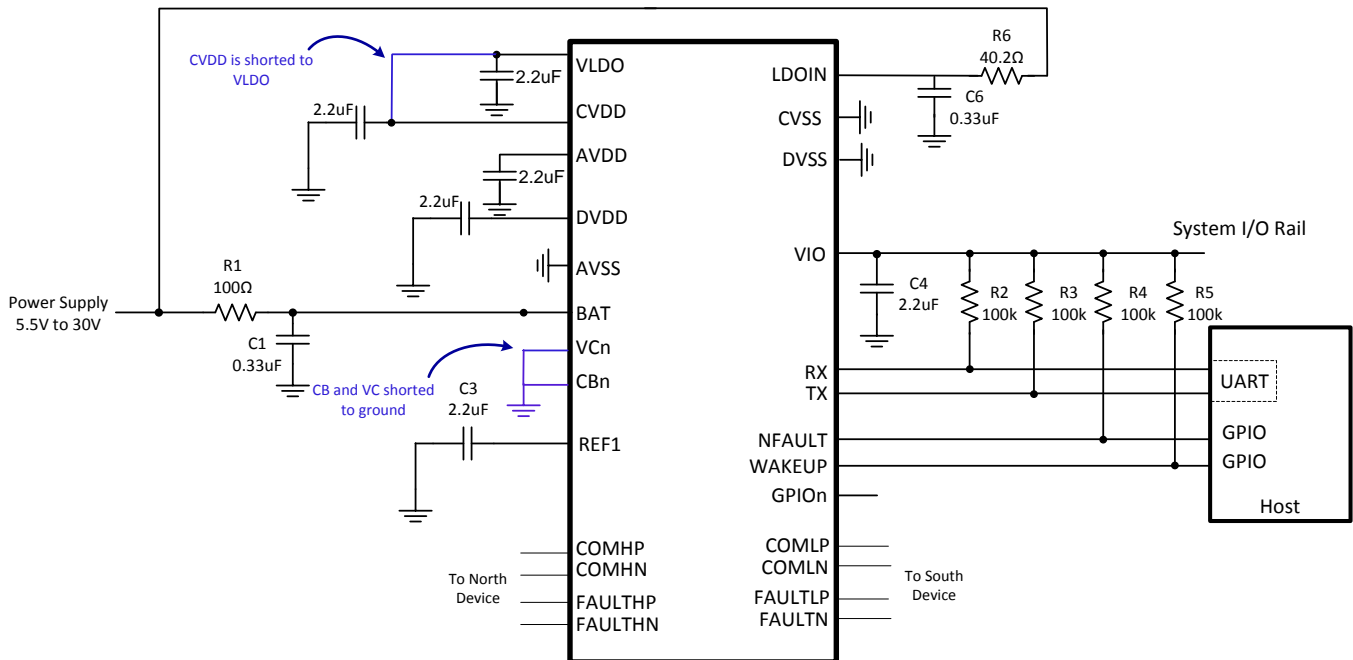

Figure 56. Typical Application Circuit for Bridge Device for Input Supply From 5.5V to 30V

### 9.2.2.1 Design Requirements

Table 35 below shows the design requirements.

**Table 35. Recommended Design Requirements**

Parameter	Value
Module Voltage Range	4.75V to 30V
Number of Cell for each device	0 cells
VCELL Voltage Range	0V

**9.2.2.2 Detailed Design Procedure**

See [Detailed Design Procedure](#) for information.

**9.2.2.3 Application Curves**

The plots below show the positive effect of re-clocking. The figure on the left captures the communication line of the first device in the stack of 16 (channel 1). The figure on the right shows the communication line of the last device in the stack (in this case device 16) channel 3. Both plots shows 250ns pulse duration. Bit compression is not present and the difference between bit-widths is 0, even with higher device counts. Without re-clocking, the pulse width of the last device in the stack will experience bit compression and eventually communication loss. With re-clocking this issue is solved and the number of device in the stack can increase as high as 64 devices without experiencing any communication loss. The other benefit of this feature is the ability to support longer cable length.

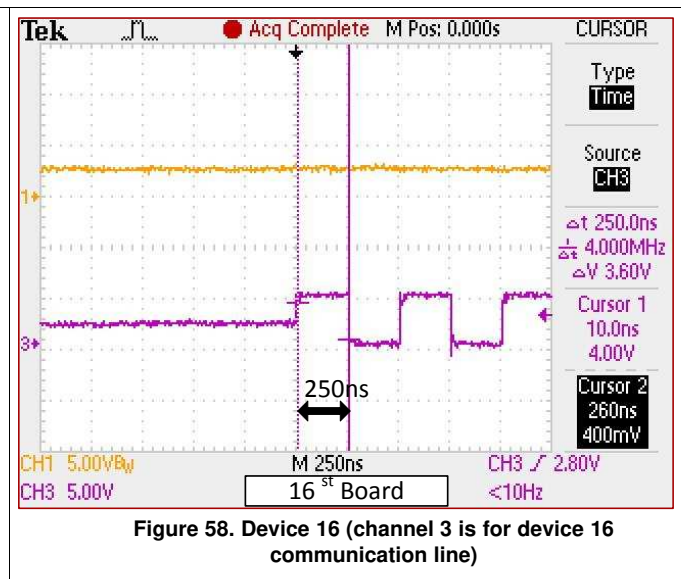
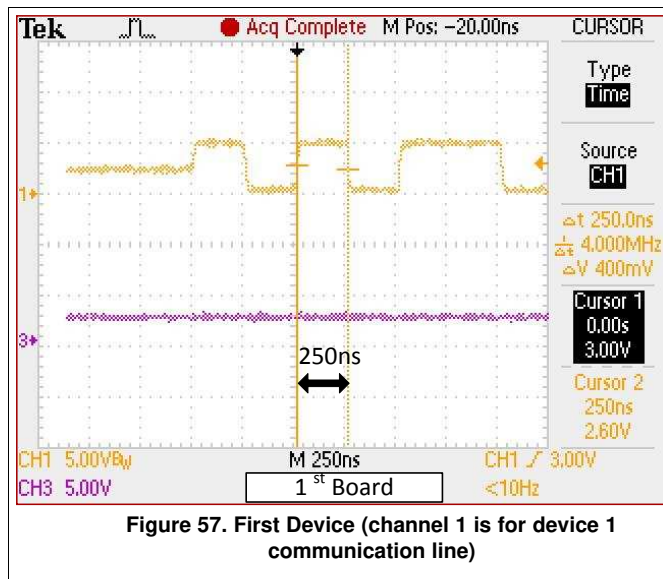

**9.2.3 Capacitor Isolated System**

Capacitive only isolation is recommended for same board communication, short cable, or in low noise applications. However, capacitor plus choke can be used for communication between boards. With a choke added, the capacitive isolation shows a very robust communication of up to 300mA BCI noise with 2m cable.

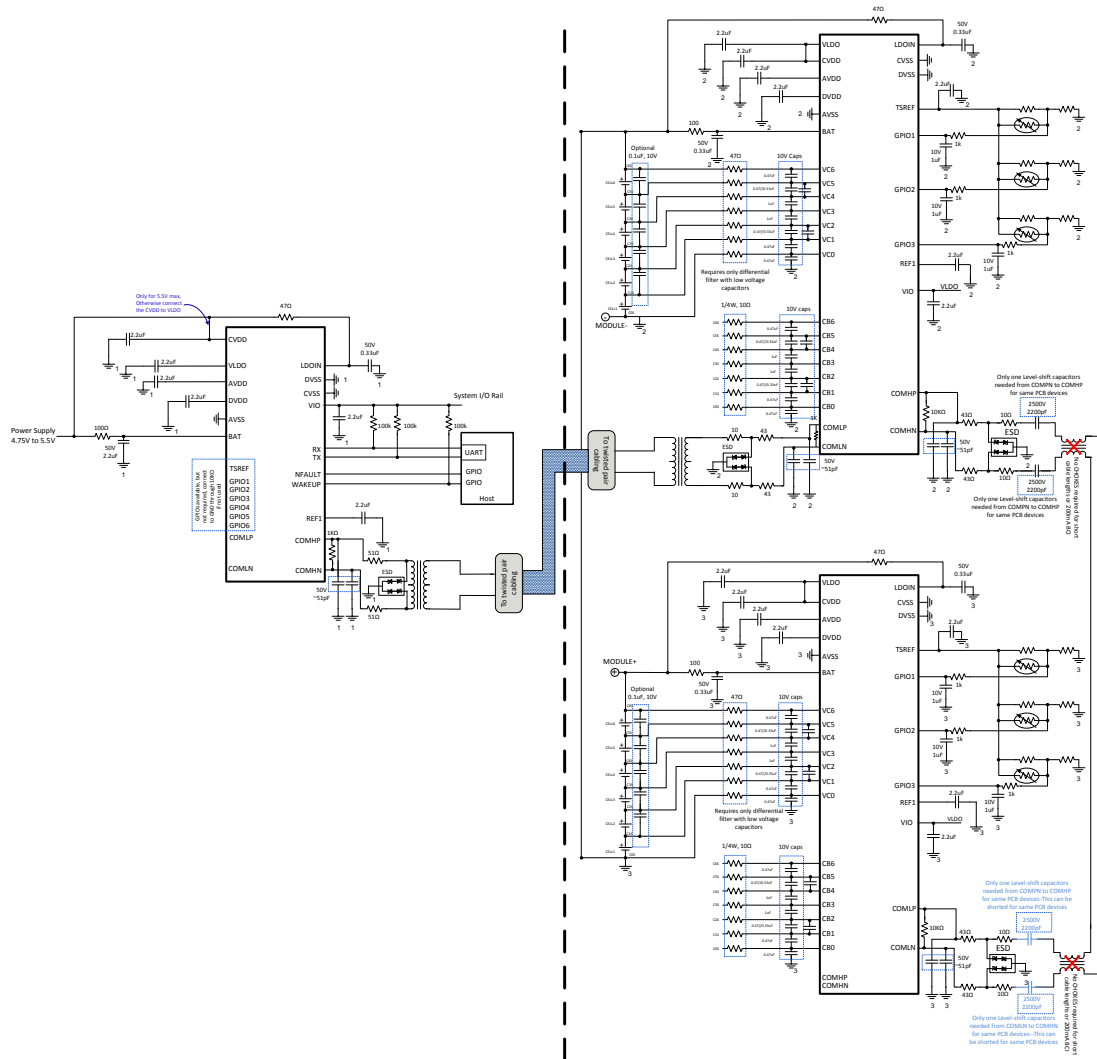

Figure 59. Typical Module Application Circuit with Capacitor Isolation without Ring Configuration

9.2.3.1 Design Requirements

Table 36. Recommended Design Requirements

Parameter	Value
Module Voltage Range	5.5V to 30V
Number of Cell for each device	3 to 6 cells
VCELL Voltage Range	0V to 5V

9.2.3.2 Detailed Design Procedure

See [Detailed Design Procedure](#) for information.

9.2.3.3 Application Curves

The picture below shows the advantage of the integrated digital low pass filter (the filter comes free as it is already integrated into the device). It compares a results 1.2Hz filter vs. 180Hz filter when a 50Hz/6Vpp noise injected into the sense lines. The 1.2Hz filter filters all noise whereas the 180Hz passes all the noise to the output.

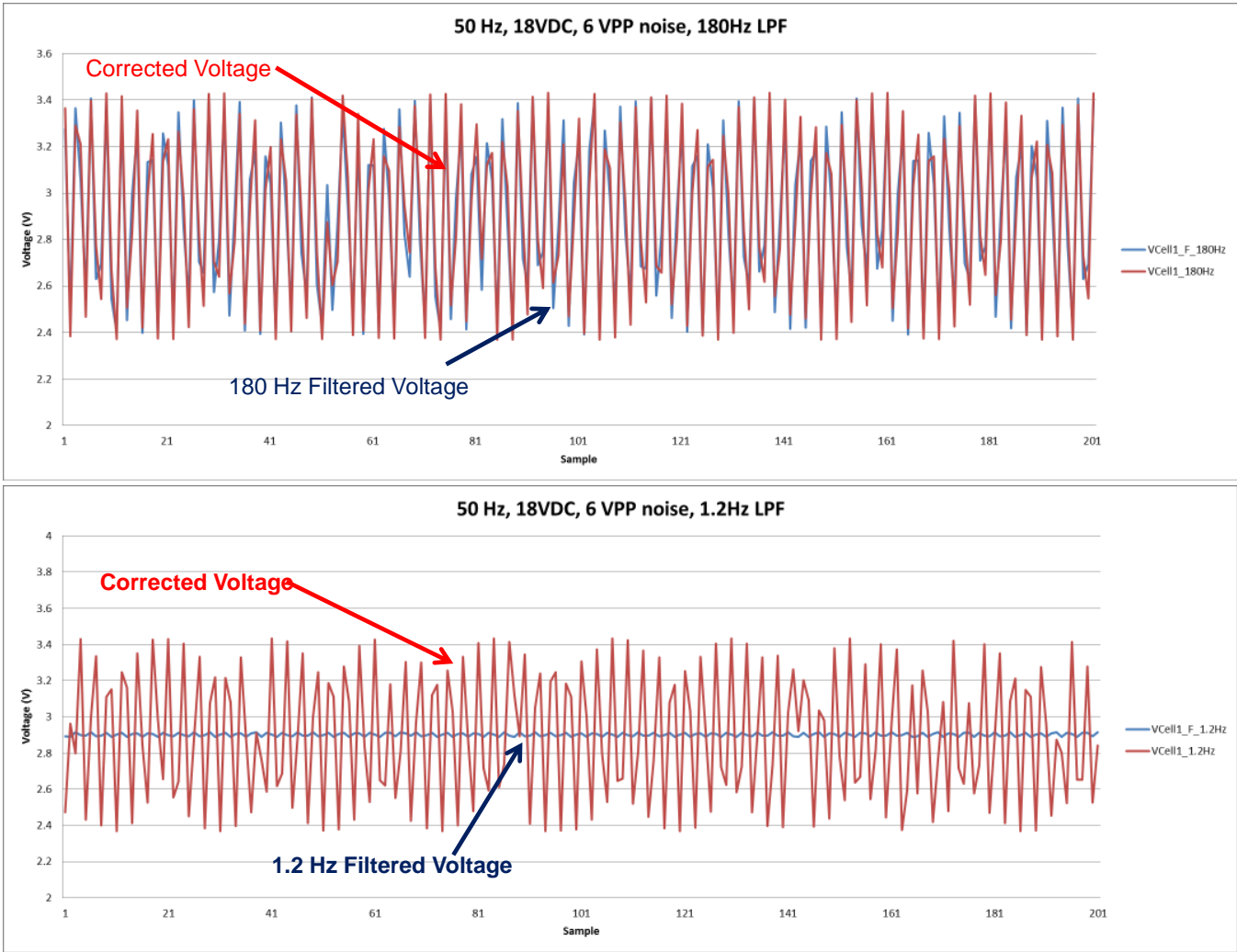

Figure 60. Digital Low Pass Filter Results

9.2.4 Transformer Isolated System

The figure below shows a typical application circuit for 14 channels Module. The high voltage to low voltage connection must be done with transformer isolation. The same PCB connection can be done with capacitor only isolation. The connection between boards can be done with capacitor plus choke isolation. The module is a 14 channels where 3 devices of BQ79606A-Q1 are used. In the first two devices 5 channels are connect to each device. The third device has only 4 channels(5 by 5 by 4). A 6 by 4 by 4 configuration can also be done to support 14 channels. The VC and CB pins that are not required are shorted to the highest connection.

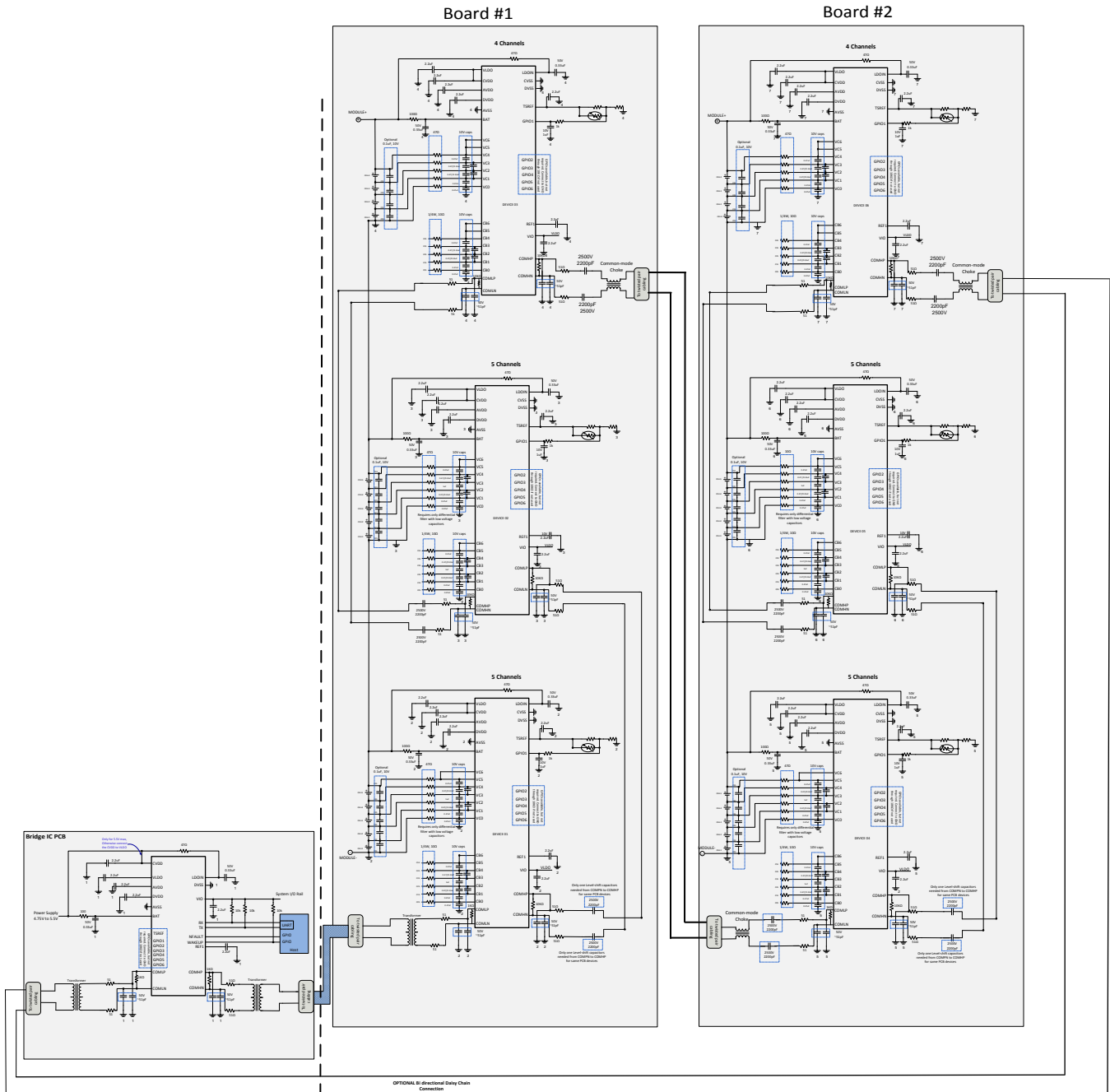

Figure 61. Typical Application Circuit for 14S Module Application with Transformer Isolation and Ring Configuration, Caps + Choke Between Boards, and Cap Only in the Same Board

9.2.4.1 Design Requirements

Table 37. Recommended Design Requirements

Parameter	Value
Module Voltage Range	5.5V to 30V
Number of Cell for each device	3 to 6 cells
VCELL Voltage Range	0V to 5V

### 9.2.4.2 Detailed Design Procedure

See [Detailed Design Procedure](#) for information.

### 9.2.4.3 Application Curves

The figure below shows BCI results for capacitive, capacitive plus choke, and transformer isolation. The test are done according the ISO 11452-4 standard. The cable length is 1.7m and baud rate is set to 1Mbps. The BCI noise is injected on the communication lines.

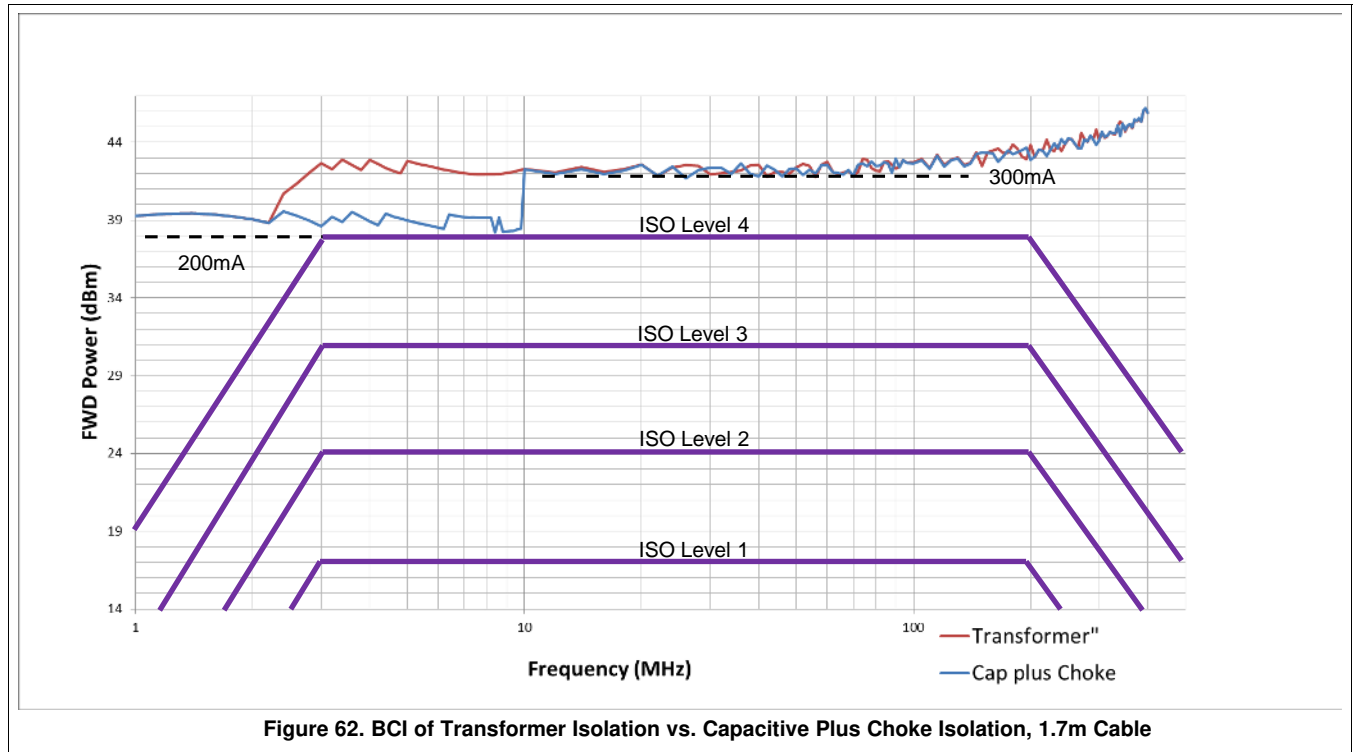

### 9.2.5 Multi-Drop System

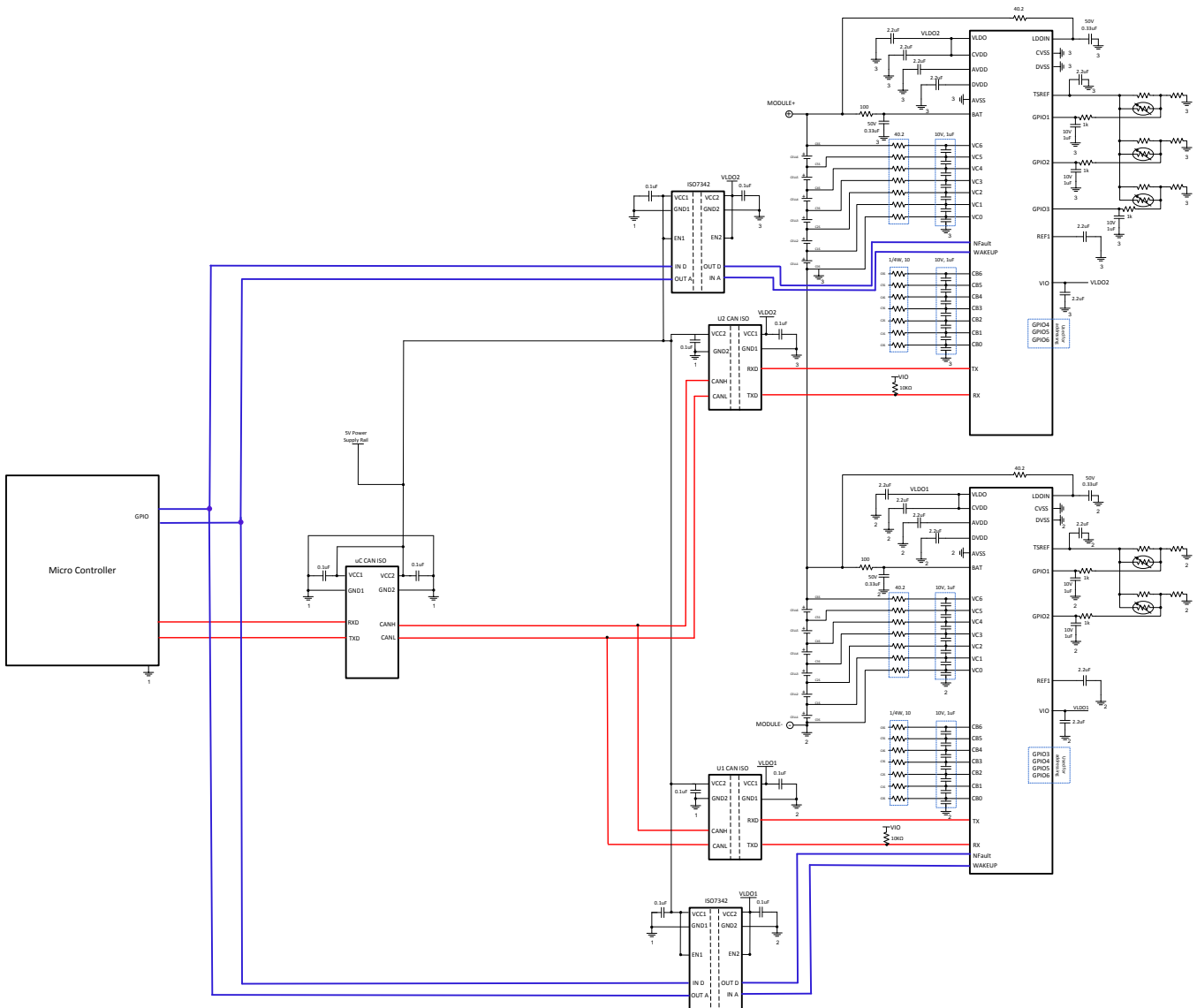

Figure 63. Typical Module Application Circuit with Multi-Drop Configuration

#### 9.2.5.1 Design Requirements

Table 38. Recommended Design Requirements

Parameter	Value
Module Voltage Range	5.5V to 30V
Number of Cell for each device	3 to 6 cells
VCELL Voltage Range	0V to 5V

#### 9.2.5.2 Detailed Design Procedure

See [Detailed Design Procedure](#) for information.

#### 9.2.5.3 Application Curves

The figure below shows a single read of register C2 of device 5 in Multi drop communication.

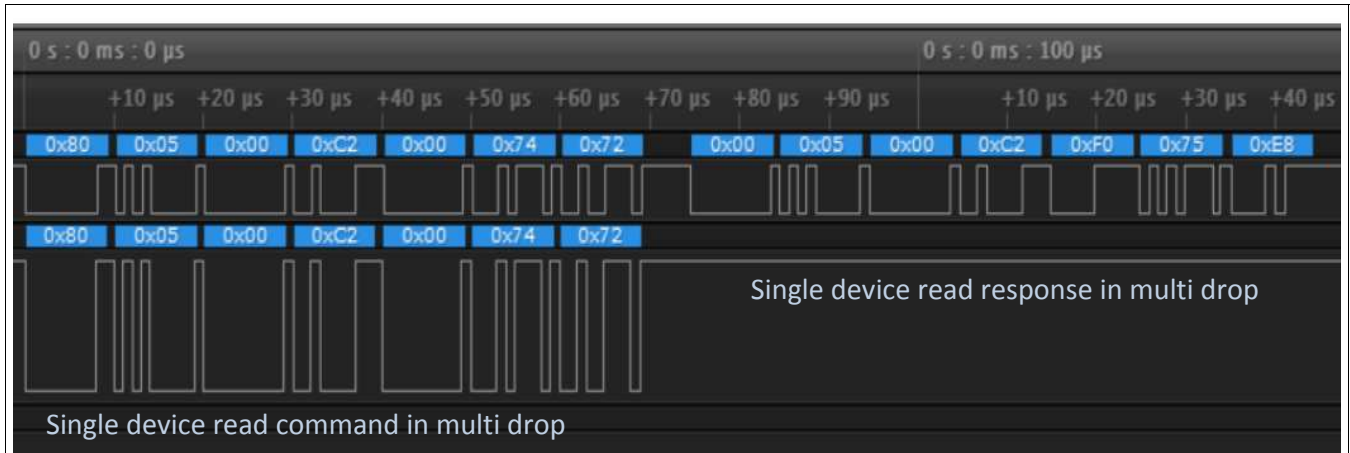

Figure 64. Multi Drop Communication





## Integrated Base Device System (continued)

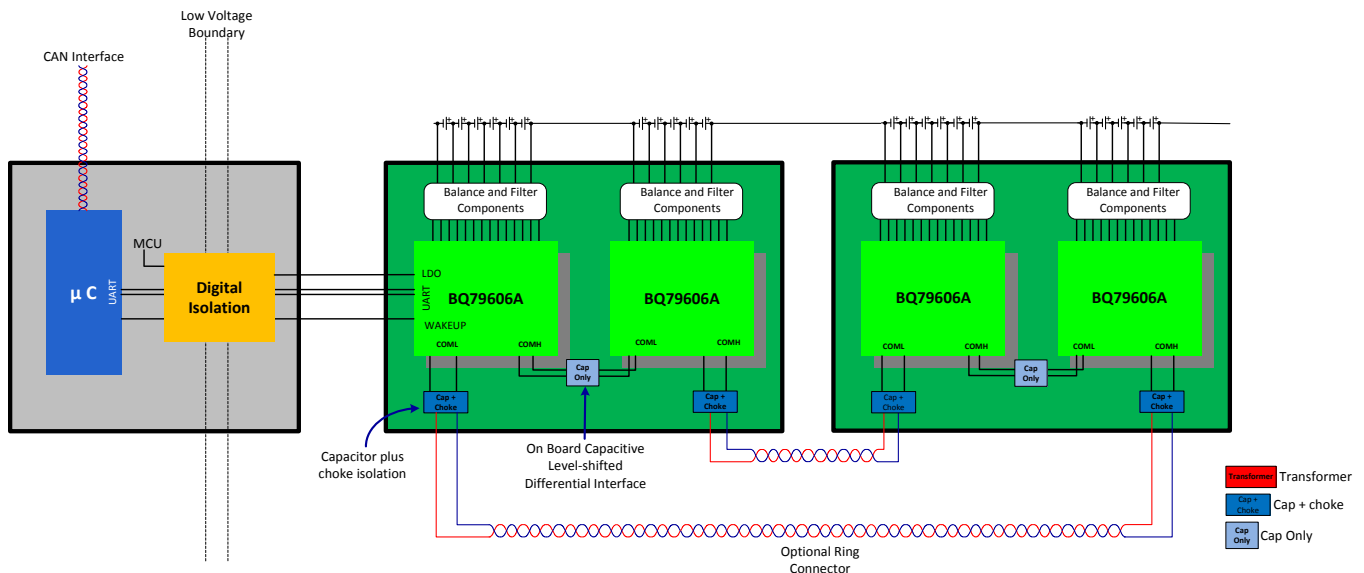

Figure 66. System Application with Integrated Base Device

### 10.3 Multi-Drop System

A third application does not use the daisy-chain interface. Instead, all devices on the bus are seen as base devices. In this mode, all devices are connected in parallel and do not support the auto-addressing scheme. The addressing must be done sequentially using the GPIOs or individual writes before assembly. No specific bus arbitration is done, however, broadcast reads are supported using a similar methodology as the stack interface. In the multi-drop setup where a CAN transceiver is used (as in Figure 66), all devices RX inputs receive the TX communications from the other devices on the bus. In this configuration, the IC waits for the next highest address device to respond. Once it receives that response (must be CRC validated), it send its own response. The host must leave the bus clear during responses. There is no collision arbitration built in, where the BQ79606A-Q1 knows its communication has been stepped on. If the communication is interrupted (either by collision or failed CRC check) before all devices have responded, none of the remaining devices respond. A communication clear must be sent to clear the bus. Stack Read, Stack Write, and Write Reverse Direction are not supported in multi-drop configuration.

Multi-Drop System (continued)

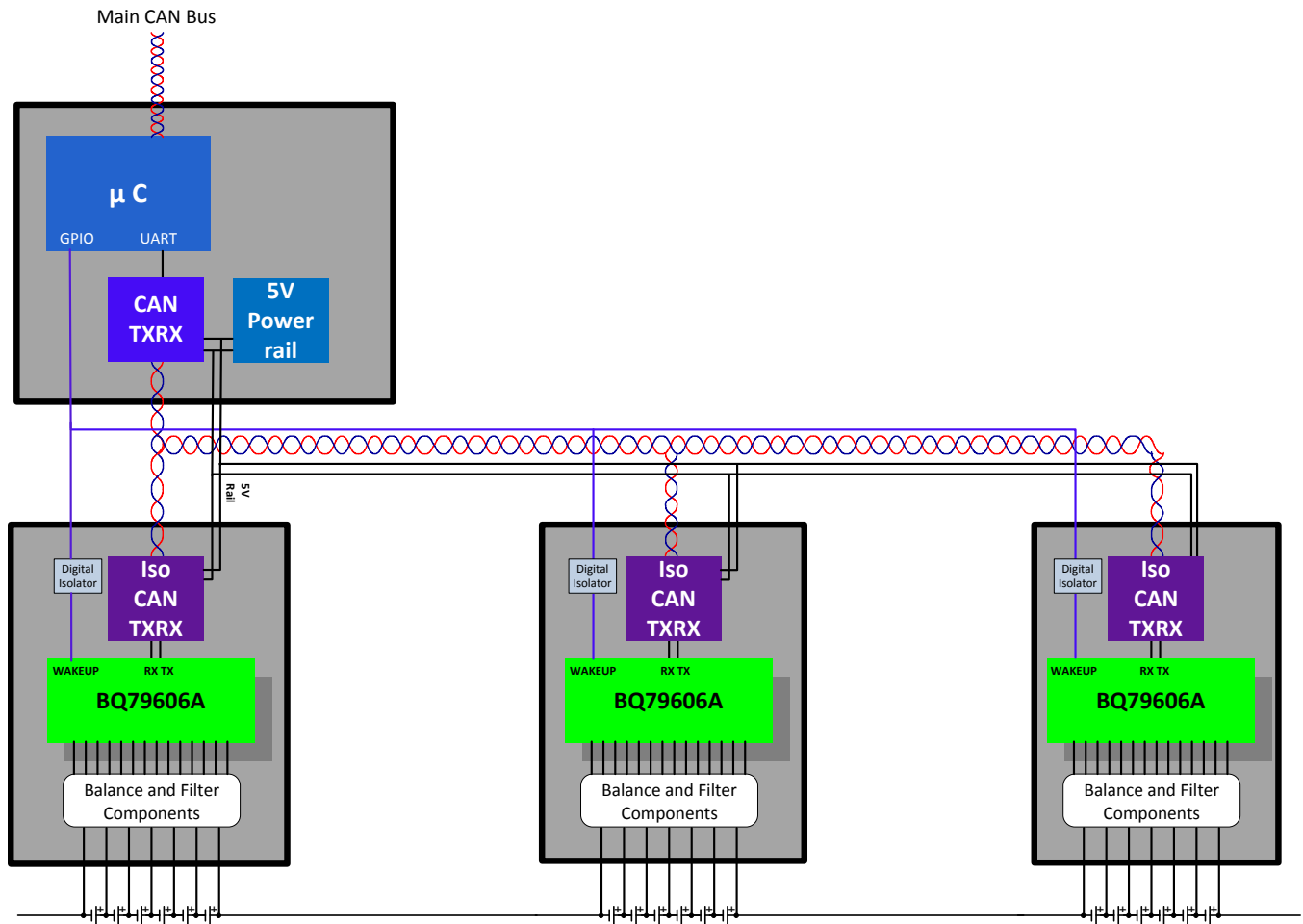

Figure 67. System Application with Multi-Drop Base Devices

## 11 Layout

### 11.1 Layout Guidelines

The layout of BQ79606A-Q1 must be designed carefully. Design outside these guidelines can affect the ADC accuracy, cell balancing thermal performance, EMI performance and so on. Care must be taken in the layout of signals to and from the device to avoid coupling noise onto sensitive inputs. The layout of ground and power connections, as well as communication signals should also be made carefully.

#### 11.1.1 Grounding

The BQ79606A-Q1 has two analog ground pins termed AVSS pin 15 and 45. AVSS of pin 15 is a general-purpose analog ground associated with quiet grounds for sensitive internal analog circuitry and circuits supplied by VIO. The AVSS of pin 45 is used for the ADC internally, connect the decoupling capacitor of the REF1 to this pin for best ADC accuracy. The BQ79606A-Q1 device also has one CVSS pin for the daisy chain communication supply (CVDD). One DVSS pin is also present, supplying the ground for the internal digital core and supporting circuitry. In addition to these 4 ground pins, a power pad is located on the bottom of the device, and should be included in the GND plane to facilitate heat dissipation.

Creation of a good ground plane in the layout is crucial to getting optimal performance from the part. A good ground plane on a dedicated layer will improve measurement accuracy, reduce noise, and provide the necessary ESD, EMI, and EMC performance. There is a strong recommendation to have a minimum of four layers in the PCB, with one fully dedicated as an unbroken ground plane (except thermal reliefs). Avoid placing tracks on this layer to maintain the unbroken integrity of the plane structure.

All 4 device grounds, as well as the power pad, should connect to the ground plane with as short as possible track sections to minimize the effects of stray inductance on noise performance.

If more than one BQ79606A-Q1 is included on a single PCB assembly, each will require its own plane in the area surrounding the device. This is required because each device has its own VSS reference, often separated by more than 21V from VSS-to-VSS of adjacent ICs in the stack. These can exist on the same physical layer, with correct separation and clearance requirements.

Although the plane is employed as a solid GND reference with all grounds connected to it, good layout practice still requires locating any decoupling capacitors as close to the pin they are associated with as possible. This reduces inductance and keeps the loop area as small as possible, which in turn keeps the capacitors as effective as possible in reducing noise. In this document, the reference term for combined grounds connected to the ground plane is ground or GND.

The layout of BQ79606A-Q1 has 3 grounds:

1. AVSS (pin 15): This is an Analog Ground. This pin must not be left unconnected and must be connected to the CVSS and DVSS externally. This ground is the ground connection for internal analog circuits.
2. AVSS (pin 45): This is an analog Ground. Pin 45 is not connected to pin 15 internally. Ground connection for internal ADC circuits. It is important for best ADC accuracy to connect as close as possible the decoupling capacitor of the REF1 to this pin. Connect CVSS, DVSS, and AVSS externally. This pin must not be left unconnected and must be connected to the CVSS and DVSS externally.
3. CVSS (pin 26): This is the ground for the Daisy chain communication. Connect AVSS, CVSS, and DVSS externally. CVSS must NOT be left unconnected.
4. DVSS (pin 35): This is digital ground. Connect AVSS, CVSS, and DVSS externally. DVSS must NOT be left unconnected.

#### 11.1.2 Differential Communication

The BQ79606A-Q1 uses two differential communications links to transmit signals between ICs in a stack. Employing differential links provides superior noise immunity. The base device then translates the differential signals back to a single-ended signal. It is important to maintain the signal integrity of each differential pair to maximize immunity to interfering signals from external sources.

1. Keep wires and PCB traces as short as possible. Do not exceed datasheet recommendations.
2. For any single-signal pair between two nodes (ICs), individual wires and traces should have the same length.
3. Unshielded, twisted-pair wiring is required for any cable runs.
4. Run PCB traces in parallel, on the same layer, without any other traces or planes in between. Long runs

## Layout Guidelines (continued)

should avoid noisy traces and/or be stitched at intervals similar to twisted-pair wire.

5. Use high-quality capacitors for voltage isolation between ICs and place in close physical proximity to each other as part of the parallel-track layout.

In addition to capacitor based communication, the BQ79606A-Q1 also supports transformer based communications. In general, the recommendations above still apply, except for item 5. For transformer based communication, be sure to select a transformer that provides isolation appropriate for the specific application.

### 11.1.3 Power Supplies and Reference

The layout for the BQ79606A-Q1 power supplies and references must be done properly to minimize noise.

1. REF1 (pin 46): This is High-Power Reference Bypass Connection. Make sure to connect the cap as close as possible to the REF1 and AVSS pin 45 and the trace is noise free.
2. TSREF (pin 43): Bias Voltage for temperature sensing (NTC) Monitor. The decoupling capacitor must be placed as close as possible to the pin. Leave TSREF unconnected if the NTC monitoring is not used.
3. DVDD (pin 36): This is a digital 1.8V regulator. The decoupling capacitor must be placed as close as possible to the pin and make the trace noise free as possible.
4. CVDD (pin 25): This is Daisy Chain Communication Power. The decoupling capacitor must be placed as close as possible to the pin and make the trace noise free as possible.
5. AVDD (pin 44): This is 5-V Regulator Output. The decoupling capacitor must be placed as close as possible to the pin and make the trace noise free as possible.
6. VLDO (pin 39): This is a 5-V Regulator Output. VLDO supplies CVDD. Bypass VLDO to AVSS with ceramic capacitor of typical value of 2.2 $\mu$ F and place it as close as possible to the pin.

## 11.2 Layout Example

To ensure the best possible accuracy performance, TI recommends following some basic layout guidelines for the bq769606-Q1 to provide best EMI and BCI performance. The isolation caps must be placed close to the edge of the board. The Common Mode Chokes must be close to the daisy-chain cable connector to provide a high-impedance path to common-mode noise as it enters the board. Place the series resistors and TVS diodes next to the BQ79606A-Q1.

An unbroken ground plane layer as part of a four or more layer board is recommended, with all AVSS, CVSS, DVSS, and power pad connections made directly to the plane. The common GND planes, the cell balance 0 pin (CB0), and cell voltage sense 0 pin (VC0) are all three star connected directly to BAT0. There should also be a keep-out area on plane area adjacent to the isolation capacitors or transformers if daisy-chain communication is implemented. The following is a list of grounds.

1. AVSS (pin 15)– Power section (noisy GND) and VIO circuitry.
2. AVSS (pin 45)– Power section (noisy free GND) used for REF1 and the internal ADC circuitry. Any noise injected into this pin will affect the ADC accuracy and performance.
3. CVSS – Power Section for Daisy Chain.
4. DVSS – Digital GND.

Layout Example (continued)

Keep as many signal traces as possible on Top and Bottom Layers and an unbroken internal GND Plane

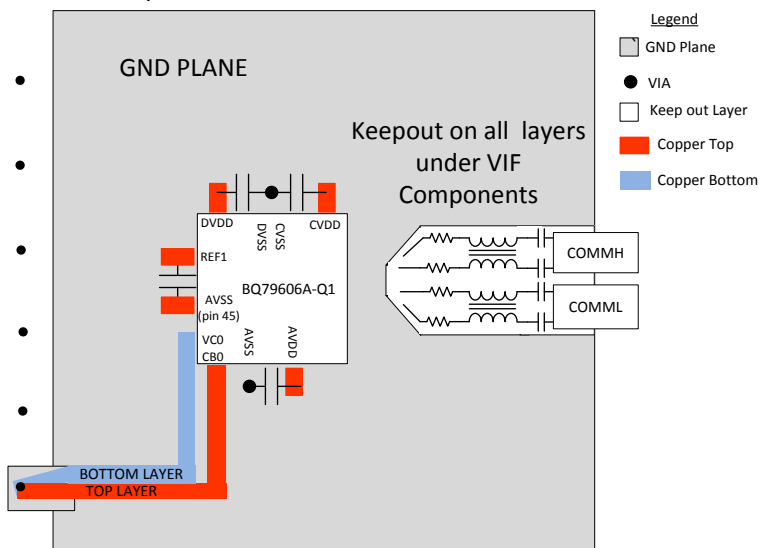

All BQ79606A-Q1 decoupling caps should be as close to the IC pin as possible

Figure 68. Layout Example

## 12 Device and Documentation Support

### 12.1 Receiving Notification of Documentation Updates

To receive notification of documentation updates, navigate to the device product folder on ti.com. In the upper right corner, click on *Alert me* to register and receive a weekly digest of any product information that has changed. For change details, review the revision history included in any revised document.

### 12.2 Community Resource

The following links connect to TI community resources. Linked contents are provided "AS IS" by the respective contributors. They do not constitute TI specifications and do not necessarily reflect TI's views; see TI's [Terms of Use](#).

**TI E2E™ Online Community** *TI's Engineer-to-Engineer (E2E) Community*. Created to foster collaboration among engineers. At e2e.ti.com, you can ask questions, share knowledge, explore ideas and help solve problems with fellow engineers.

**Design Support** *TI's Design Support* Quickly find helpful E2E forums along with design support tools and contact information for technical support.

### 12.3 Trademarks

SafeTI, E2E are trademarks of Texas Instruments.  
All other trademarks are the property of their respective owners.

### 12.4 Electrostatic Discharge Caution



These devices have limited built-in ESD protection. The leads should be shorted together or the device placed in conductive foam during storage or handling to prevent electrostatic damage to the MOS gates.

### 12.5 Glossary

[SLYZ022](#) — *TI Glossary*.

This glossary lists and explains terms, acronyms, and definitions.

### **13 Mechanical, Packaging, and Orderable Information**

The following pages include mechanical, packaging, and orderable information. This information is the most current data available for the designated devices. This data is subject to change without notice and revision of this document. For browser-based versions of this data sheet, refer to the left-hand navigation.



**PACKAGING INFORMATION**

Orderable Device	Status (1)	Package Type	Package Drawing	Pins	Package Qty	Eco Plan (2)	Lead finish/ Ball material (6)	MSL Peak Temp (3)	Op Temp (°C)	Device Marking (4/5)	Samples
BQ79606APHRQ1	ACTIVE	HTQFP	PHP	48	1000	RoHS & Green	NIPDAU	Level-3-260C-168 HR	-40 to 105	BQ79606	<a href="#">Samples</a>
BQ79606APHPTQ1	ACTIVE	HTQFP	PHP	48	250	RoHS & Green	NIPDAU	Level-3-260C-168 HR	-40 to 105	BQ79606	<a href="#">Samples</a>

(1) The marketing status values are defined as follows:

**ACTIVE:** Product device recommended for new designs.

**LIFEBUY:** TI has announced that the device will be discontinued, and a lifetime-buy period is in effect.

**NRND:** Not recommended for new designs. Device is in production to support existing customers, but TI does not recommend using this part in a new design.

**PREVIEW:** Device has been announced but is not in production. Samples may or may not be available.

**OBSOLETE:** TI has discontinued the production of the device.

(2) **RoHS:** TI defines "RoHS" to mean semiconductor products that are compliant with the current EU RoHS requirements for all 10 RoHS substances, including the requirement that RoHS substance do not exceed 0.1% by weight in homogeneous materials. Where designed to be soldered at high temperatures, "RoHS" products are suitable for use in specified lead-free processes. TI may reference these types of products as "Pb-Free".

**RoHS Exempt:** TI defines "RoHS Exempt" to mean products that contain lead but are compliant with EU RoHS pursuant to a specific EU RoHS exemption.

**Green:** TI defines "Green" to mean the content of Chlorine (Cl) and Bromine (Br) based flame retardants meet JS709B low halogen requirements of <=1000ppm threshold. Antimony trioxide based flame retardants must also meet the <=1000ppm threshold requirement.

(3) MSL, Peak Temp. - The Moisture Sensitivity Level rating according to the JEDEC industry standard classifications, and peak solder temperature.

(4) There may be additional marking, which relates to the logo, the lot trace code information, or the environmental category on the device.

(5) Multiple Device Markings will be inside parentheses. Only one Device Marking contained in parentheses and separated by a "~" will appear on a device. If a line is indented then it is a continuation of the previous line and the two combined represent the entire Device Marking for that device.

(6) Lead finish/Ball material - Orderable Devices may have multiple material finish options. Finish options are separated by a vertical ruled line. Lead finish/Ball material values may wrap to two lines if the finish value exceeds the maximum column width.

**Important Information and Disclaimer:**The information provided on this page represents TI's knowledge and belief as of the date that it is provided. TI bases its knowledge and belief on information provided by third parties, and makes no representation or warranty as to the accuracy of such information. Efforts are underway to better integrate information from third parties. TI has taken and continues to take reasonable steps to provide representative and accurate information but may not have conducted destructive testing or chemical analysis on incoming materials and chemicals. TI and TI suppliers consider certain information to be proprietary, and thus CAS numbers and other limited information may not be available for release.

In no event shall TI's liability arising out of such information exceed the total purchase price of the TI part(s) at issue in this document sold by TI to Customer on an annual basis.

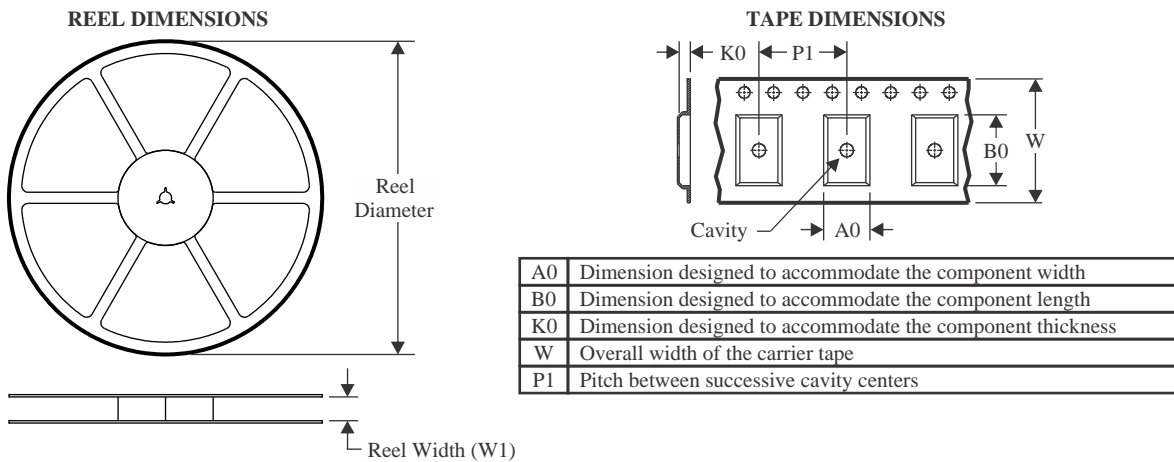

**TAPE AND REEL INFORMATION**

**QUADRANT ASSIGNMENTS FOR PIN 1 ORIENTATION IN TAPE**

\*All dimensions are nominal

Device	Package Type	Package Drawing	Pins	SPQ	Reel Diameter (mm)	Reel Width W1 (mm)	A0 (mm)	B0 (mm)	K0 (mm)	P1 (mm)	W (mm)	Pin1 Quadrant
BQ79606APHRQ1	HTQFP	PHP	48	1000	330.0	16.4	9.6	9.6	1.5	12.0	16.0	Q2

**TAPE AND REEL BOX DIMENSIONS**

\*All dimensions are nominal

Device	Package Type	Package Drawing	Pins	SPQ	Length (mm)	Width (mm)	Height (mm)
BQ79606APHRQ1	HTQFP	PHP	48	1000	350.0	350.0	43.0

## GENERIC PACKAGE VIEW

**PHP 48**

**TQFP - 1.2 mm max height**

7 x 7, 0.5 mm pitch

QUAD FLATPACK

This image is a representation of the package family, actual package may vary.  
Refer to the product data sheet for package details.

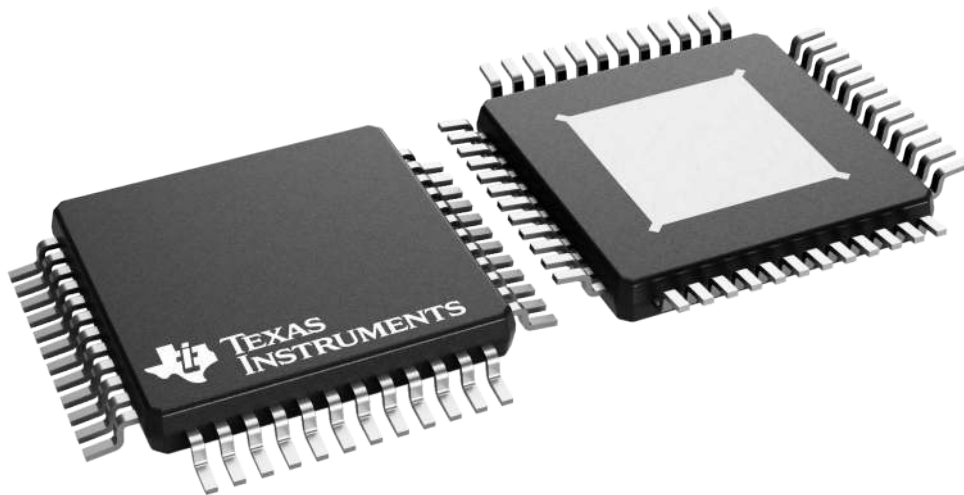

4226443/A

# PACKAGE OUTLINE

PHP0048G

PowerPAD™ HTQFP - 1.2 mm max height

PLASTIC QUAD FLATPACK

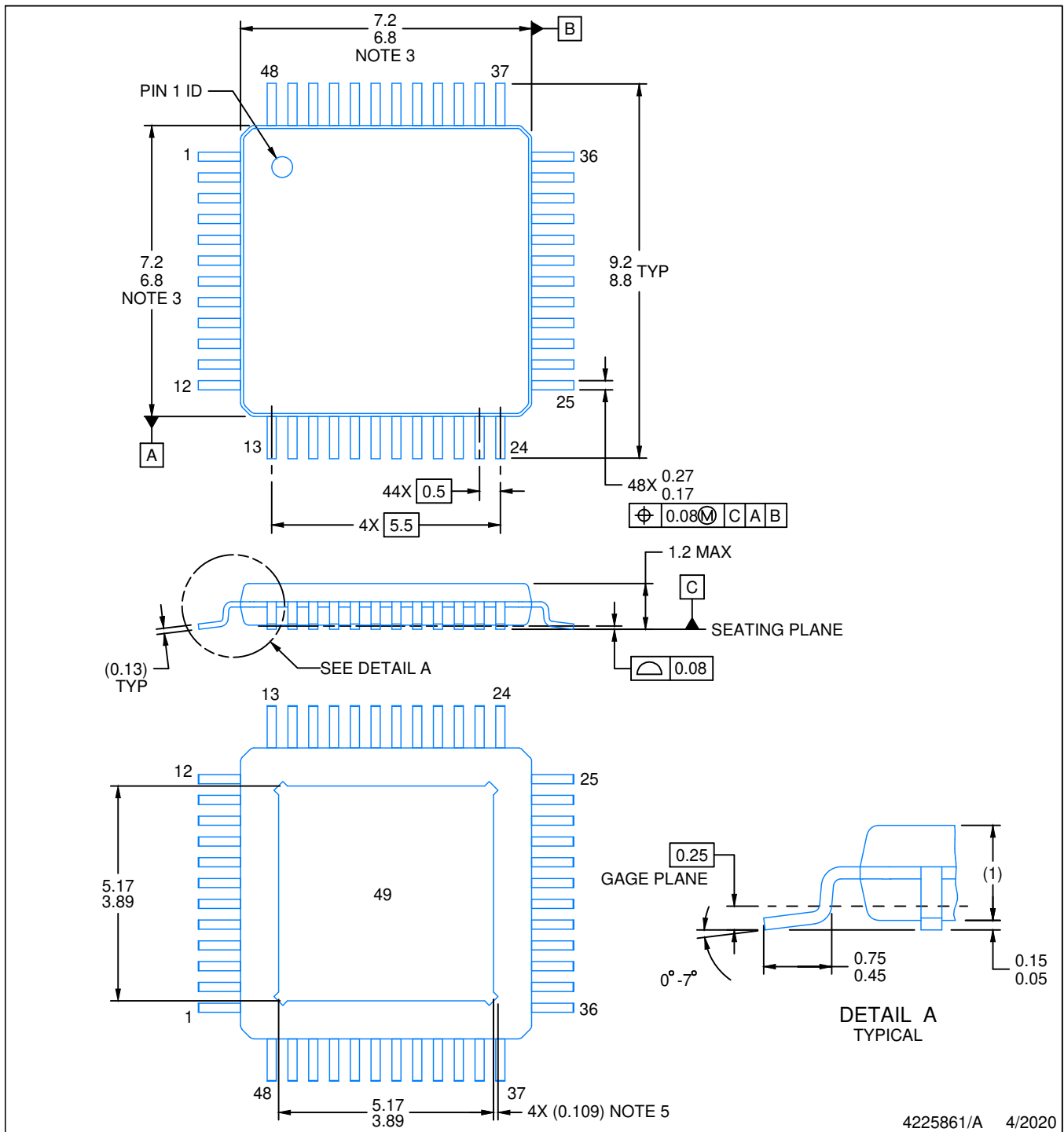

**NOTES:**

PowerPAD is a trademark of Texas Instruments.

1. All linear dimensions are in millimeters. Any dimensions in parenthesis are for reference only. Dimensioning and tolerancing per ASME Y14.5M.
2. This drawing is subject to change without notice.
3. This dimension does not include mold flash, protrusions, or gate burrs. Mold flash, protrusions, or gate burrs shall not exceed 0.15 mm per side.
4. Reference JEDEC registration MS-026.
5. Feature may not be present.

# EXAMPLE BOARD LAYOUT

PHP0048G

PowerPAD™ HTQFP - 1.2 mm max height

PLASTIC QUAD FLATPACK

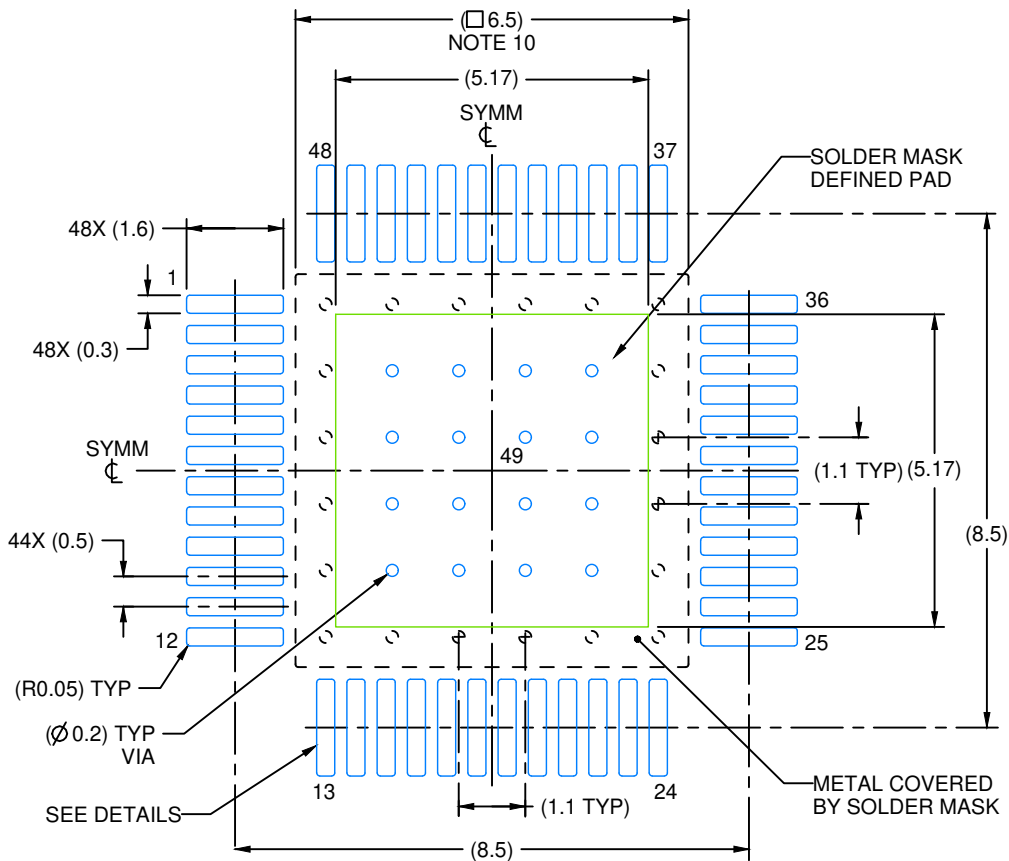

LAND PATTERN EXAMPLE  
EXPOSED METAL SHOWN  
SCALE:8X

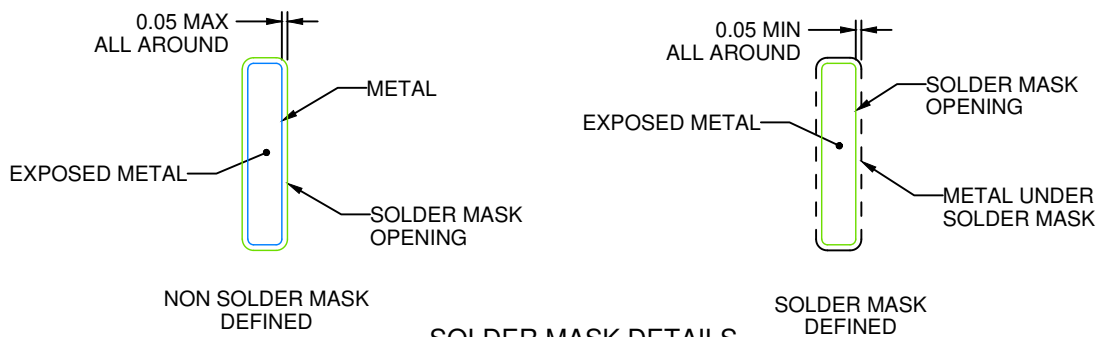

SOLDER MASK DETAILS

4225861/A 4/2020

NOTES: (continued)

6. Publication IPC-7351 may have alternate designs.
7. Solder mask tolerances between and around signal pads can vary based on board fabrication site.
8. This package is designed to be soldered to a thermal pad on the board. See technical brief, Powerpad thermally enhanced package, Texas Instruments Literature No. SLMA002 ([www.ti.com/lit/slma002](http://www.ti.com/lit/slma002)) and SLMA004 ([www.ti.com/lit/slma004](http://www.ti.com/lit/slma004)).
9. Vias are optional depending on application, refer to device data sheet. It is recommended that vias under paste be filled, plugged or tented.
10. Size of metal pad may vary due to creepage requirement.

# EXAMPLE STENCIL DESIGN

PHP0048G

PowerPAD™ HTQFP - 1.2 mm max height

PLASTIC QUAD FLATPACK

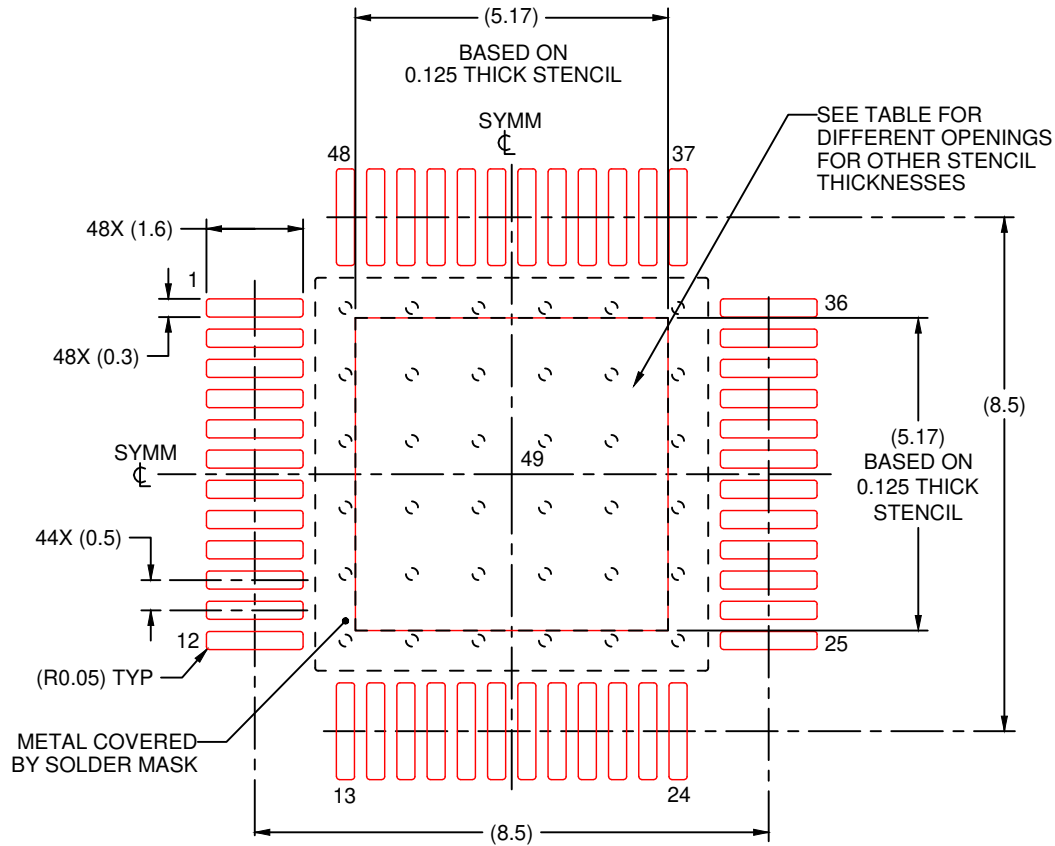

SOLDER PASTE EXAMPLE  
EXPOSED PAD  
100% PRINTED SOLDER COVERAGE BY AREA  
SCALE:8X

STENCIL THICKNESS	SOLDER STENCIL OPENING
0.1	5.78 X 5.78
0.125	5.17 X 5.17 (SHOWN)
0.150	4.72 X 4.72
0.175	4.37 X 4.37

4225861/A 4/2020

NOTES: (continued)

11. Laser cutting apertures with trapezoidal walls and rounded corners may offer better paste release. IPC-7525 may have alternate design recommendations.
12. Board assembly site may have different recommendations for stencil design.



# PHP0048N

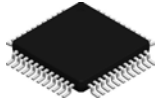

# PACKAGE OUTLINE

## PowerPAD™ HTQFP - 1.2 mm max height

PLASTIC QUAD FLATPACK

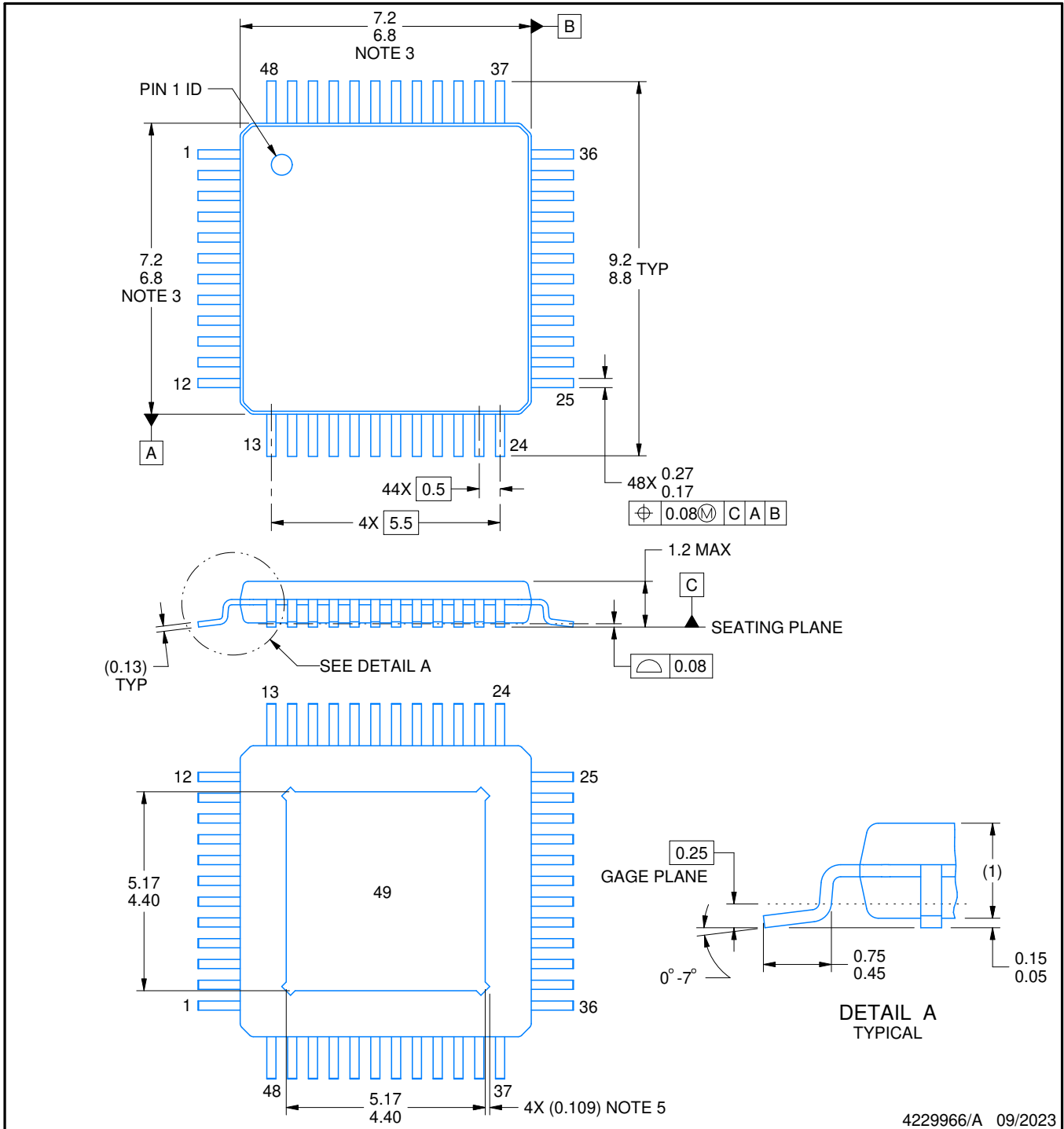

4229966/A 09/2023

**NOTES:**

PowerPAD is a trademark of Texas Instruments.

1. All linear dimensions are in millimeters. Any dimensions in parenthesis are for reference only. Dimensioning and tolerancing per ASME Y14.5M.
2. This drawing is subject to change without notice.
3. This dimension does not include mold flash, protrusions, or gate burrs. Mold flash, protrusions, or gate burrs shall not exceed 0.15 mm per side.
4. Reference JEDEC registration MS-026.
5. Feature may not be present.

# EXAMPLE BOARD LAYOUT

PHP0048N

PowerPAD™ HTQFP - 1.2 mm max height

PLASTIC QUAD FLATPACK

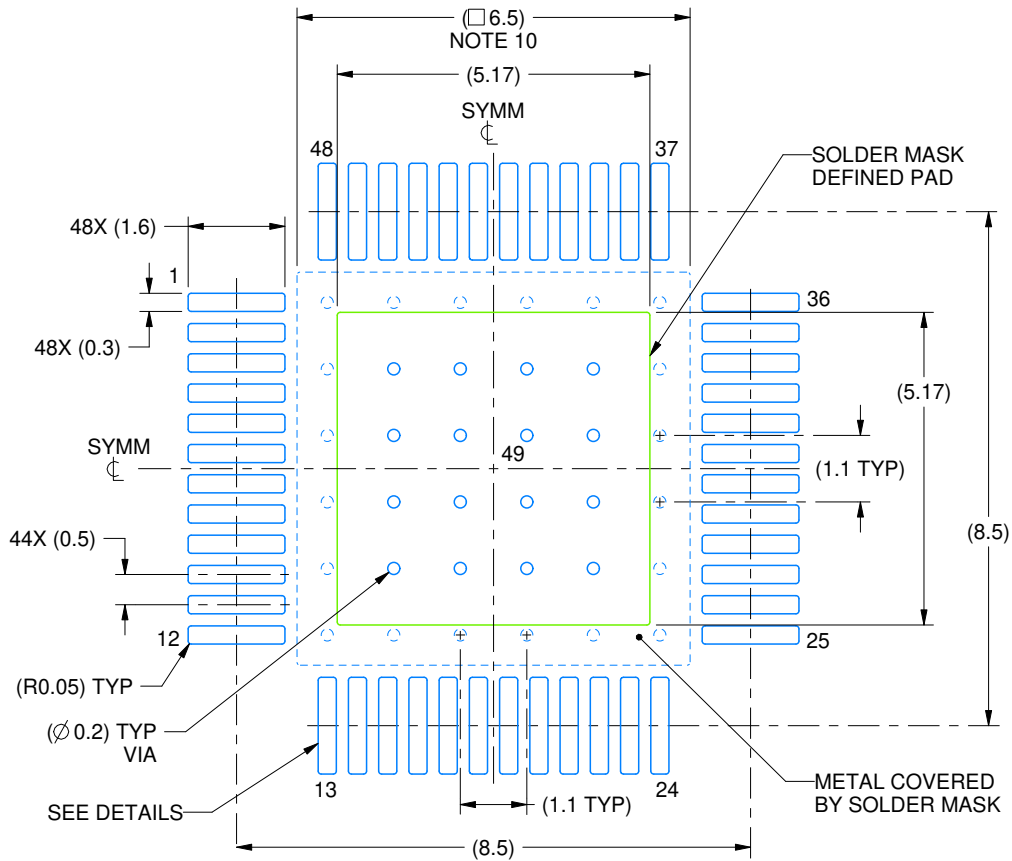

LAND PATTERN EXAMPLE  
EXPOSED METAL SHOWN  
SCALE:8X

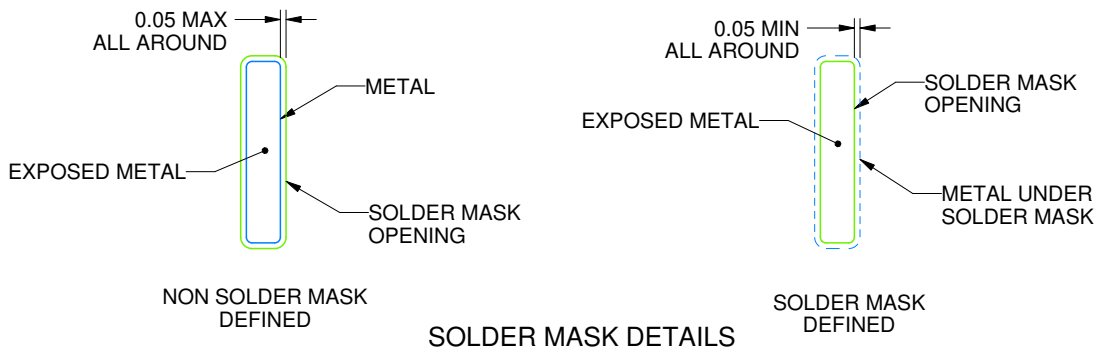

4229966/A 09/2023

NOTES: (continued)

6. Publication IPC-7351 may have alternate designs.
7. Solder mask tolerances between and around signal pads can vary based on board fabrication site.
8. This package is designed to be soldered to a thermal pad on the board. See technical brief, Powerpad thermally enhanced package, Texas Instruments Literature No. SLMA002 ([www.ti.com/lit/slma002](http://www.ti.com/lit/slma002)) and SLMA004 ([www.ti.com/lit/slma004](http://www.ti.com/lit/slma004)).
9. Vias are optional depending on application, refer to device data sheet. It is recommended that vias under paste be filled, plugged or tented.
10. Size of metal pad may vary due to creepage requirement.

# EXAMPLE STENCIL DESIGN

PHP0048N

PowerPAD™ HTQFP - 1.2 mm max height

PLASTIC QUAD FLATPACK

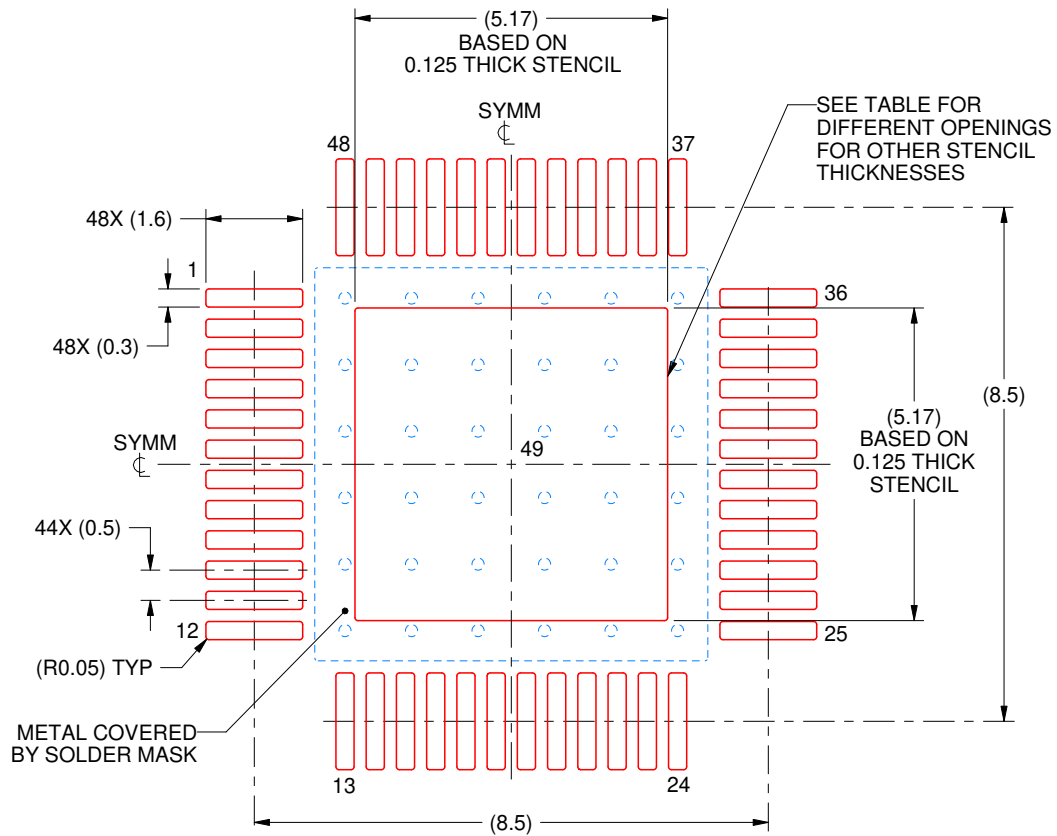

SOLDER PASTE EXAMPLE  
EXPOSED PAD  
100% PRINTED SOLDER COVERAGE BY AREA  
SCALE:8X

STENCIL THICKNESS	SOLDER STENCIL OPENING
0.1	5.78 X 5.78
0.125	5.17 X 5.17 (SHOWN)
0.150	4.72 X 4.72
0.175	4.37 X 4.37

4229966/A 09/2023

NOTES: (continued)

11. Laser cutting apertures with trapezoidal walls and rounded corners may offer better paste release. IPC-7525 may have alternate design recommendations.
12. Board assembly site may have different recommendations for stencil design.

## IMPORTANT NOTICE AND DISCLAIMER

TI PROVIDES TECHNICAL AND RELIABILITY DATA (INCLUDING DATA SHEETS), DESIGN RESOURCES (INCLUDING REFERENCE DESIGNS), APPLICATION OR OTHER DESIGN ADVICE, WEB TOOLS, SAFETY INFORMATION, AND OTHER RESOURCES "AS IS" AND WITH ALL FAULTS, AND DISCLAIMS ALL WARRANTIES, EXPRESS AND IMPLIED, INCLUDING WITHOUT LIMITATION ANY IMPLIED WARRANTIES OF MERCHANTABILITY, FITNESS FOR A PARTICULAR PURPOSE OR NON-INFRINGEMENT OF THIRD PARTY INTELLECTUAL PROPERTY RIGHTS.

These resources are intended for skilled developers designing with TI products. You are solely responsible for (1) selecting the appropriate TI products for your application, (2) designing, validating and testing your application, and (3) ensuring your application meets applicable standards, and any other safety, security, regulatory or other requirements.

These resources are subject to change without notice. TI grants you permission to use these resources only for development of an application that uses the TI products described in the resource. Other reproduction and display of these resources is prohibited. No license is granted to any other TI intellectual property right or to any third party intellectual property right. TI disclaims responsibility for, and you will fully indemnify TI and its representatives against, any claims, damages, costs, losses, and liabilities arising out of your use of these resources.

TI's products are provided subject to [TI's Terms of Sale](#) or other applicable terms available either on [ti.com](https://www.ti.com) or provided in conjunction with such TI products. TI's provision of these resources does not expand or otherwise alter TI's applicable warranties or warranty disclaimers for TI products.

TI objects to and rejects any additional or different terms you may have proposed.

Mailing Address: Texas Instruments, Post Office Box 655303, Dallas, Texas 75265  
Copyright © 2023, Texas Instruments Incorporated