

## TMC-UPS-10A70V-EVAL Evaluation Board

Hardware Version V1.10 | Document Revision V1.20 • 2019-APR-15

The TMC-UPS-10A70V-EVAL is a universal Power Stage for usage with TMC8670-EVAL. It drives up to 10A of current and is tolerant to supply voltages up to 70V. It uses half bridge gate drivers and discrete MOSFETs as well as standard connectors for supply and motor connection. Current measurement is implemented by inline shunt amplifiers.

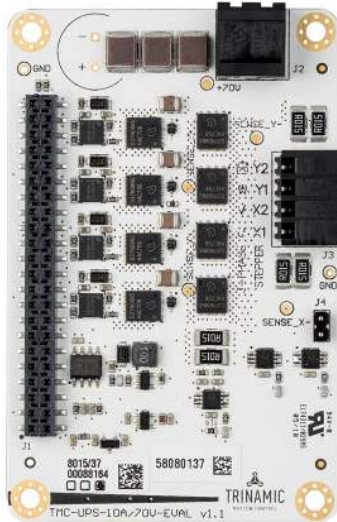

### Features

- Power Stage for the TMC8670-EVAL
- 4 independent Half-Bridges with Gate Driver and Phase Current up to 10A RMS for driving a 2-phase stepper motor, or a 3-phase BLDC or a single phase DC motor.
- Main Supply Voltage (VM) up to 70V
- Supply for Gatedrivers and Shunt Amplifiers (zero current level = 3.3V/2)
- 2 Phase Current shunt amplifiers and one for bottom shunt with +/-10A measurement range

### Applications

- Laboratory Automation
- Manufacturing
- Semiconductor Handling
- Robotics
- Factory Automation
- Test & Measurement
- Life Science
- Biotechnology
- Liquid Handling

### Simplified Block Diagram

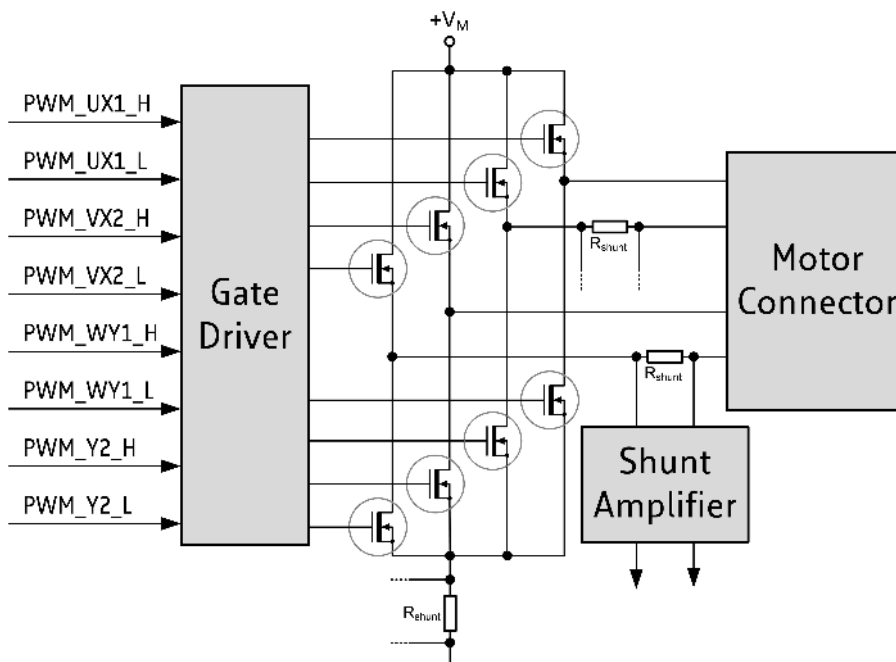

©2021 TRINAMIC Motion Control GmbH & Co. KG, Hamburg, Germany  
 Terms of delivery and rights to technical change reserved.  
 Download newest version at: [www.trinamic.com](http://www.trinamic.com)



Read entire documentation.

## Contents

<b>1</b>	<b>Getting Started</b>	<b>3</b>
<b>2</b>	<b>Hardware Information</b>	<b>3</b>
2.1	Connectors . . . . .	3
<b>3</b>	<b>Usage with own Motion Controller</b>	<b>4</b>
<b>4</b>	<b>Supply Voltage for Shunt Amplifiers</b>	<b>5</b>
<b>5</b>	<b>Revision History</b>	<b>6</b>
5.1	Document Revision . . . . .	6



# 1 Getting Started

The TMC-UPS-10A70V-EVAL is a power stage module to be used in the TMC8670 Evaluation Kit. Please assemble all components properly according to guidelines in the respective Motion Controller Evaluation Board Manual.

# 2 Hardware Information

All design files for our evaluation boards are available for free. We offer the original ECAD files, Gerber data, the BOM, and PDF copies. Typically, the ECAD files are in KiCAD format. Some (older) evaluation boards may only be available in Eagle, Altium, or PADS format.

Please check schematics for Jumper settings and input/output connector description.

The files can be downloaded from the evaluation boards' website directly at <https://www.trinamic.com/support/eval-kits/>.

**Note** If files are missing on the website or something is wrong please send us a note.

## 2.1 Connectors

The TMC-UPS-10A70V-EVAL provides a motor connector, a power supply connector and a Evaluation system compliant connector to a motion controller Evaluation board. Please check silk screen for correct motor connection.

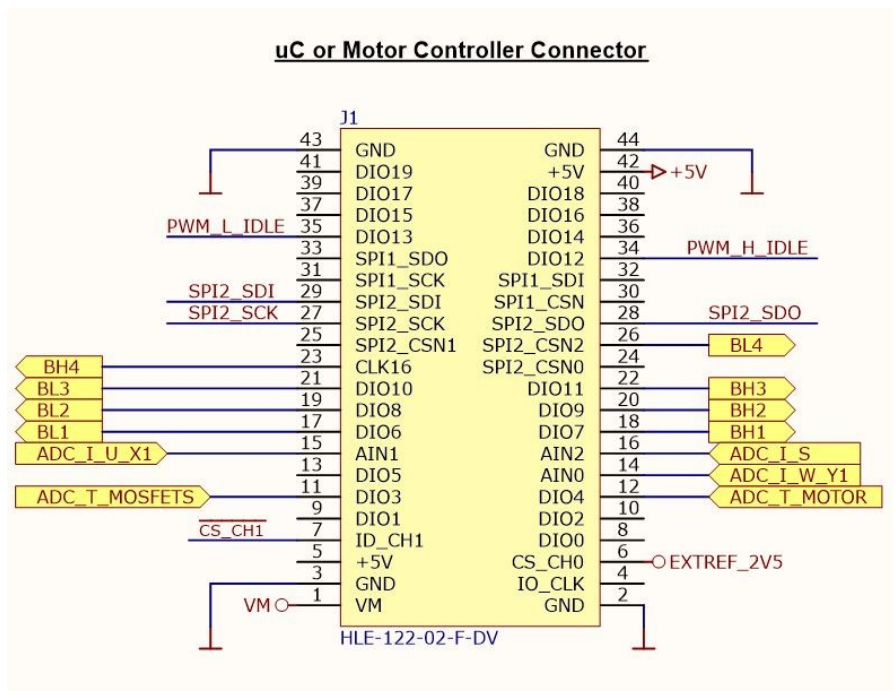

Figure 1: 44 pin Motor Controller Connector



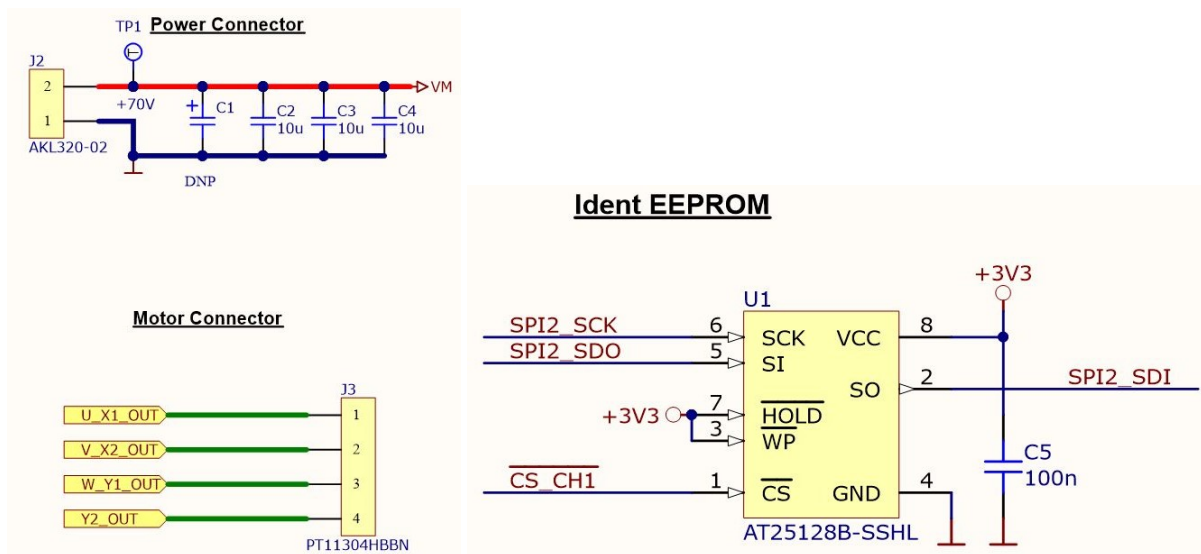

Figure 2: Motor connector, power connector and EEPROM

The evaluation board can be automatically recognized when Ident EEPROM is properly configured. This part is only needed on an Evaluation board for user convenience.

### 3 Usage with own Motion Controller

The TMC-UPS-10A70V-EVAL can be used with third party motor controller. In that case 5V needs to be supplied via the Motor Controller connector. SPI signals are not needed.



## 4 Supply Voltage for Shunt Amplifiers

With resistors R33 and R34 the supply voltage for the shunt amplifiers can be changed. The default setting is R33 = 3.3V, which results in a zero current offset of  $3.3V/2 = 1.66V$  as required by TMC8670-EVAL. When using the TMC4671-VAL, R34 should be placed (0R) and R33 should not be equipped to change the zero current offset to  $5V/2 = 2.5V$ .

Equipping both resistors will short supply voltages and probably damage the module. When using the TMC4671 and selected supply voltage is 3V3 the ADC offset will not be at medium level and not the complete current range can be measured.

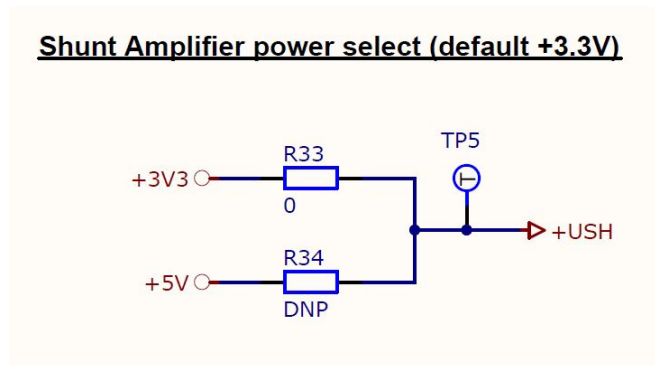

Figure 3: Power supply select for shunt amplifiers



## 5 Revision History

### 5.1 Document Revision

Version	Date	Author	Description
1.00	2018-MAY-08	OM	Initial release.
1.10	2018-OCT-15	OM	Added section 'Supply voltage for Shunt Amplifiers'.
1.20	2019-APR-15	SK	Modified information on the featured eval kit combinations and the shunt amplifier supply.

*Table 1: Document Revision*

