

**INDUCTION MOTOR SOLID-STATE REDUCED
VOLTAGE STARTER (SOFTSTARTER) WITH
SOFTSTOP FEATURE**

SMCV6080

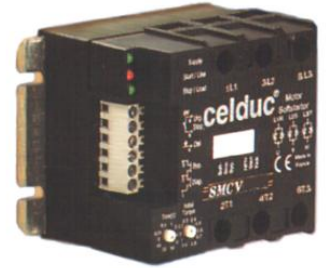

**Induction Motor
Softstarter**

**200 - 480VAC
->7.5kW (Y)
->13kW (D)**

celduc relais[®] SMCV can be employed everywhere using a costly and relatively big variable speed controller is not required (pumps, fans, compressors, conveyors, ...).

Its **six thyristor** structure working like a full wave phase angle controller (both positive and negative cycles are controlled), allows to reduce efficiently the induction motor starting current as well as the motor starting torque. This **motor starting current reduction** allows to optimize the mains grid as well as its protections and **avoid having voltage fluctuations** leading to ambient light variations also called "flicker".

Built to help the user to get his assembly in compliance with the European directives and standards, this product easy fits in the existing application without any modification of the wiring field configuration. Thus, the SMCV can easily replace an electromechanical star-delta starter **without changing the motor coupling!** In a project including a three phase induction motor it can be implemented like a usual three phase electromechanical contactor. Furthermore, its ability to be installed inside the delta wiring allows this device to drive **1.73 times more current** than a standard on line softstarter,

The SMCV also have **diagnostic and self-test functions** to inform people involved in the machine maintenance and **to reduce the cost and the delay to restart the production.**

MAIN CHARACTERISTICS

Max. Motor Power @40°C		IAC53a @40°C		Phase to Phase Voltage	Mains Frequency	Input	Status Outputs	In/Out/Case Isolation	Operating Temperature
Star (Y)	Delta (D)	With heatsink							
400VAC	230VAC	400VAC	230VAC	Max. EN60947-4-2	40 to 65Hz	10 to 24VDC	24V / 1A AC/DC	4kV	-40 to +100°C
7.5kW	4.3kW	13kW	7.5kW	16A 11.5A					

**BENEFIT FOR MOTOR STARTING
DIRECT ON LINE (DOL) STARTING**

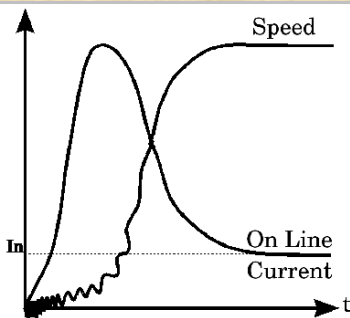

- ➔ **Mechanical part stress:**
 - noise
 - Maintenance costs
- ➔ **High inrush current:**
 - Motor and mains protections oversized
 - Risk of flicker

SOFTSTARTING WITH SMCV

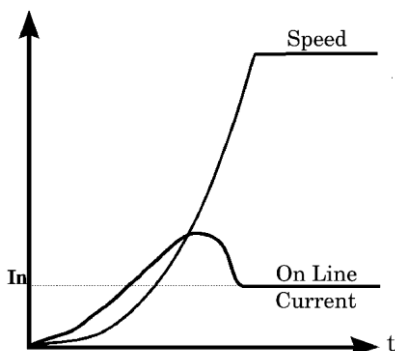

- ➔ **Softstarting:**
 - Noise reduction
 - Maintenance cost reduction
- ➔ **No more high inrush current:**
 - Motor and mains protections optimization
 - No more harmonic or flicker problems

TYPICAL WIRINGS

STAR (Y)

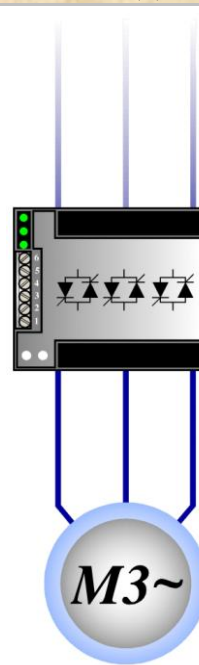

DELTA (D)

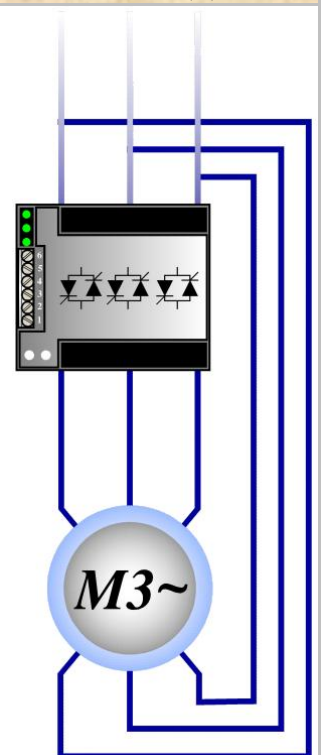

SETTINGS AND DIAGNOSTIC

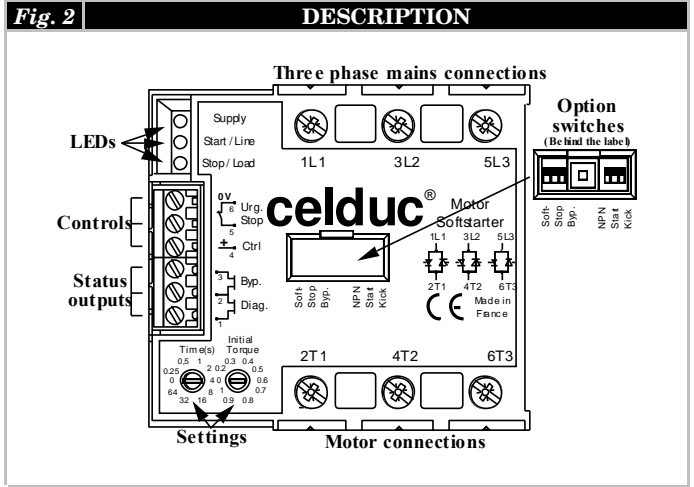
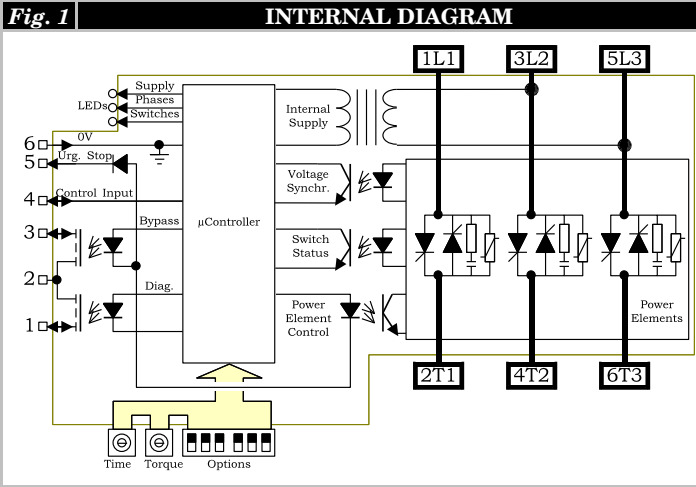

DESCRIPTION OF THE CONNECTIONS						
Terminals	1,2	2,3	4,6	5,6	1L1, 3L2, 5L3	2T1, 4T2, 6T3
Function	Diagnostic	Bypass	Control	Urgent stop	Three phase mains (Obligatory)	Motor supply (Obligatory)
Input/Output	Output	Output	Input	Input	Input	Output
Activated when ...	Closed	Closed	High (PNP) or Low (NPN)	Open	Since 3x200VAC	100ms after control
Polarization	NO (AC or DC)	NO (AC or DC)	Yes (4+ / 6-)	Yes (5+ / 6-)	NO (AC)	NO (AC)

DESCRIPTION OF THE SETTINGS AND OPTIONS						
Setting / Option	Time	Initial Torque	Soft-stop	By.	NPN / START	Kick
Function	Increasing voltage ramp duration	Min. voltage applied to the motor at start	Decreasing voltage ramp duration	Bypass presence diagnostic option (if bypass used)	Softstarter type of control option	Motor shaft breakaway
Possibilities	Ts= 0 up to 64s	0 up to 100 %	0, 1/2, 1 or 2 x ts up to 64s max.	-	PNP, NPN or since the mains presence	0 up to 100ms depending on ts
Proceeding White squares = sliders Example : = All the switches down (OFF) (Factory setting)						

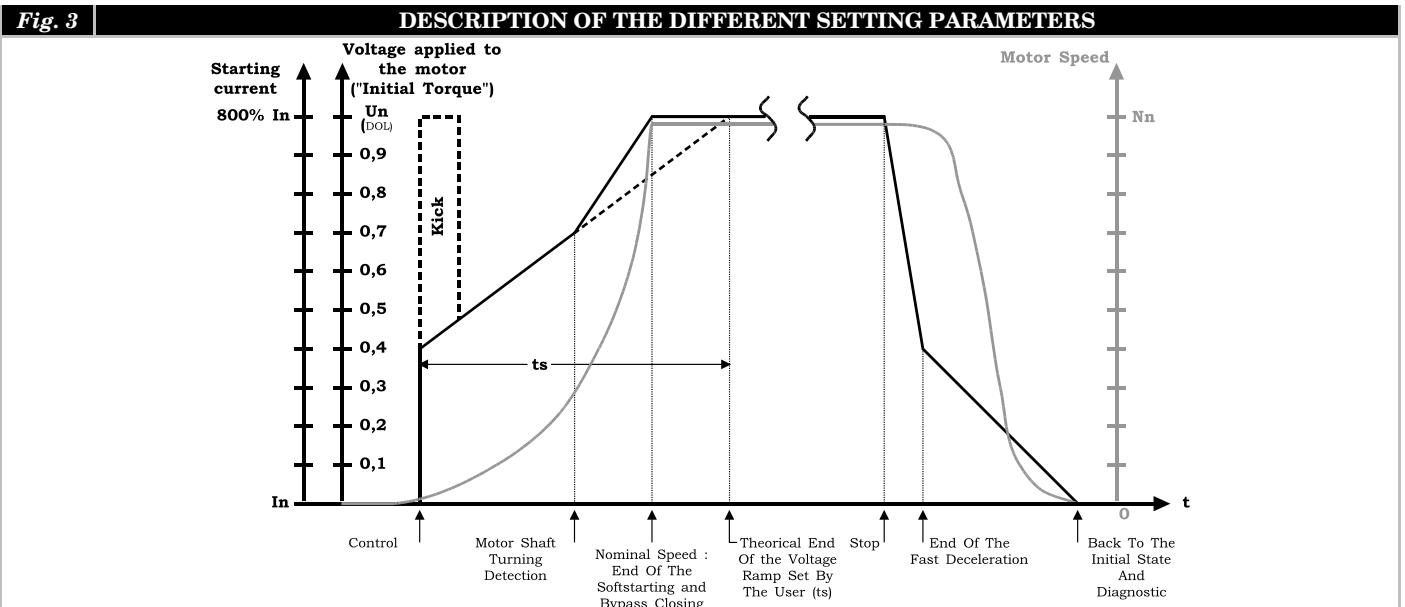

SETTINGS AND DIAGNOSTIC

DESCRIPTION OF THE DIAGNOSTIC INFORMATION IN NORMAL OPERATION

Visualization			Status Outputs		Motor	Cause probable
Supply	Line	Load	Byp.	Diag.		
○	○	○	—/—	—/—	Stopped	No mains or device not correctly wired
●	●	●	—/—	—/—	Stopped	Mains voltage and phases OK, Motor detected, No control
●	●○	○	—/—	—/—	Starting	Mains voltage and phases OK, Motor detected, Control detected and beginning of the softstarting ramp
●	●	○	—/—	—/—	Running to nominal speed	Mains voltage and phases OK, Motor detected, Control detected and end of the softstarting ramp
●	○	●○	—/—	—/—	Decelerating	Mains voltage and phases OK, Motor detected, No control and beginning of the softstopping ramp

DIAGNOSTICS IN CASE OF FAILURE

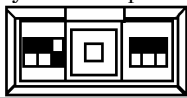
Visualization			Status Outputs		Motor	Possible Cause	Solution
Supply	Line	Load	Byp.	Diag.			
●○	○	●○	—/—	—/—	Stopped	Mains voltage too low	Check the phases 3L2 and 5L3
○	●	○	—/—	—/—	Stopped	Phase(s) missing, Mains frequency out of range, Too much interference	Check the phases
○	●	○	—/—	—/—	Running	Phase(s) missing	Check the phases
○	●	●	—/—	—/—	Stopped	Load missing, Short-circuited thyristor	Check the motor connections and the solid state switches
○	●○	●○	—/—	—/—	Stopped	Bypass missing (its checking is required by the corresponding option) 	Check the bypass connections or if not used, cancel the checking option
●○	●○	●○	—/—	—/—	Stopped	The solid state switches can not close	Check if the connection between 5 and 6 of the control terminal block is correctly done. Check as well if the load current is sufficient.
●	●	●	—/—	—/—	Stopped	Microcontroller malfunction	Disconnect the softstarter from the mains for a while
○●	●○	○	—/—	—/—	Stopped	A problem occurred on the mains (no voltage or a phase missing, ...) then disappeared but the control voltage was applied	Remove the control for a while
○●	●○	●○	—/—	—/—	Stopped	A problem occurred on the load (temporary disconnection,...) then disappeared but the control voltage was applied	Remove the control for a while

LEGEND

○	●	●	○●	○●
Off	Green	Red	Flashing off/green	Flashing Off/red

IMPORTANT INFORMATION ABOUT THE DIAGNOSTIC

- The device makes a complete diagnostic (mains, load and itself) since it has enough supply voltage (On the mains or on the control side).
- The device only checks the presence of the phases and the closing of the solid state switches during the voltage ramps (Softstart and softstop) and during the full on state period.
- The control overrides the diagnostic.
 - If a problem occurs during the control period, the device will close all the solid state switches. If the problem goes on during the full on state period, the corresponding information will be given to the user according to the table above.
 - Likewise, if a problem occurs during the softstopping period, the device will stop immediately in order to reach the off state diagnostic period.
- On a hard stop (no softstop) and case of driving a large motor, the device may temporary display a problem concerning the mains. This is due to an important residual voltage across the motor windings (Back EMF generated by the motor rotation and the remaining magnetic field). This security allows the user to avoid connecting the motor to the mains in bad conditions. This phenomenon can be cancelled by using the softstop feature that slowly reduces the remanent magnetic field inside the motor. This allows as well to avoid overvoltage across the solid state switches (increasing the lifetime expectancy of the integrated varistors). Therefore, softstop is recommended even with high inertia motor loads.

CONTROL

CONTROL INPUTS AND STATUS OUTPUTS

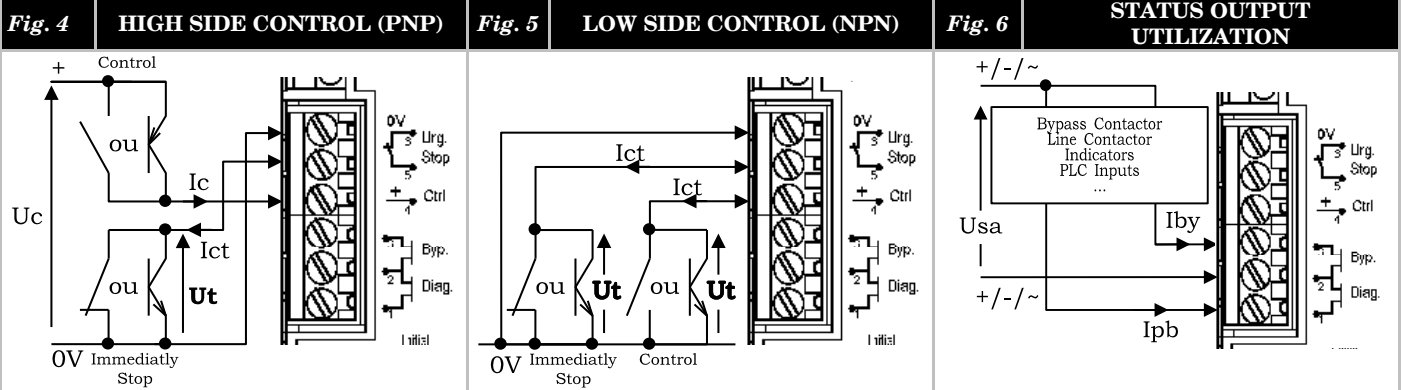

ELECTRICAL CHARACTERISTICS OF THE STARTING AND STOPPING INPUTS

CHARACTERISTICS	LABELS	VALUES (Given at 20°C ambient unless otherwise specified)			REMARKS
		Ctrl		Urg. Stop	
Input Function		Controlling the device		Immediately stop the device	
Control Type (Depending on the option switches)		High side control (PNP)	Low side control (NPN)	Opening the connection to zero volt	
Concerned Terminals		4 & 6	4 & 6	5 & 6	
Control Voltage Range (according to EN60947-4-2)	Uc	10->24VDC	-	-	
Min. Control Voltage	Ucmin.	8.5V	-	-	
Max. Voltage Drop	Ut	-	2.5VDC	1.5VDC	
Max. Input Voltage		Ucmax=28VDC	Utmax=28VDC	Utmax=6VDC	
Max. Reverse Voltage		-Ucmax=28VDC	-Utmax=28VDC	-Utmax=6VDC	
Release Voltage		Uc<1VDC	Ut>2.5VDC	Ut>1.5VDC	
Control Current	Ic	5->19mADC	-	-	See curve fig. 7 page 5
Current To Switch	Ict	-	50->100µADC	20mADC	Depends on Ut

STATUS OUTPUT CHARACTERISTICS

CHARACTERISTICS	LABELS	VALUES (Given at 20°C ambient unless otherwise specified)		REMARKS
		Diag.	Byp.	
Output Concerned Terminals		1 & 2	2 & 3	
Function		Environment problem detection or faulty device indication	Indicates the end of the starting period and can be used to control a bypass electromechanical contactor	
Nom. Operating Voltage	Usan	24VAC/DC		
Operating Voltage Range	Usa	0->28VAC/DC		
Non-repetitive Max. Peak Voltage	Usapmax	60V		
Protection Against Overvoltage		Yes 25V size 7 varistors integrated		See curves fig. 11 & 12 page 5
Min. Load Current	Ibymin Ipbmin	0		
Max. Permanent Current	Iby/Ipb	1A AC/DC		See curve fig. 8 page 5
Overload Current	Ibyp/Ipbp	2.4A AC/DC		@100ms 10% of the cycle
Protection Against Short-Circuits		No		
On-state Resistance	Ron	500mΩ		See curve fig. 9 page 5
Off-state Resistance	Roff	100MΩ		
Off-state Capacitance	Coff	130pF		See curve fig. 10 page 5
Turn-on Time	Toff	0.5ms		
Turn-off Time	Ton	2ms		

CONTROL

CHARACTERISTIC CURVES OF THE CONTROLLING INPUTS AND STATUS OUTPUTS

Fig. 7 Control Input Current/Voltage Characteristic In PNP Mode (High Side Control)

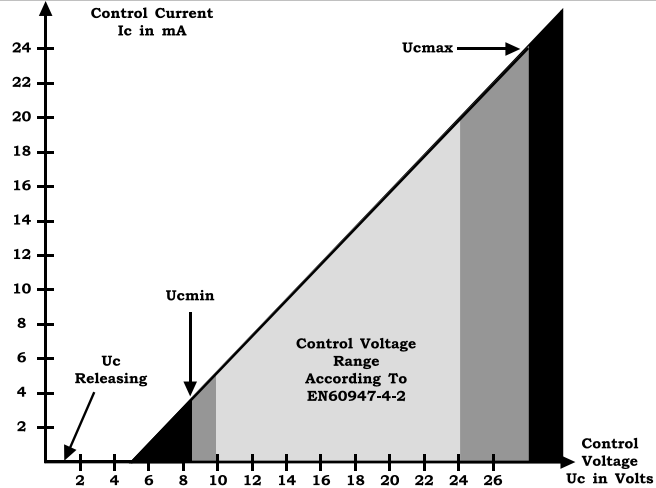

Fig. 8 Curve Giving Max. Output Status Current Versus Ambient Temperature

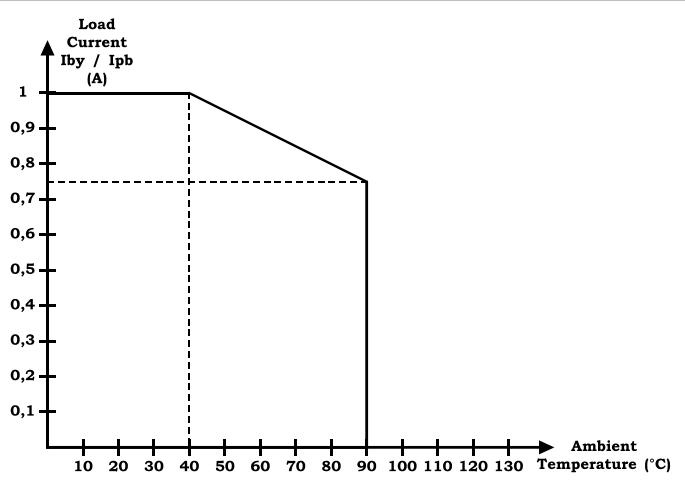

Fig. 9 Off-state Status Output Parasitic Capacitance Versus Output Voltage

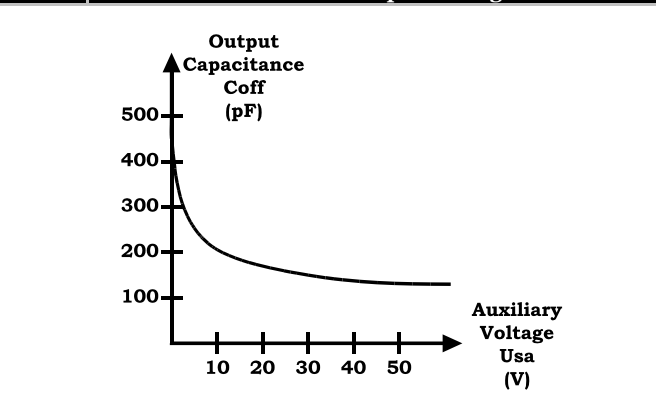

Fig. 10 On-state Status Output Resistance Versus Ambient Temperature

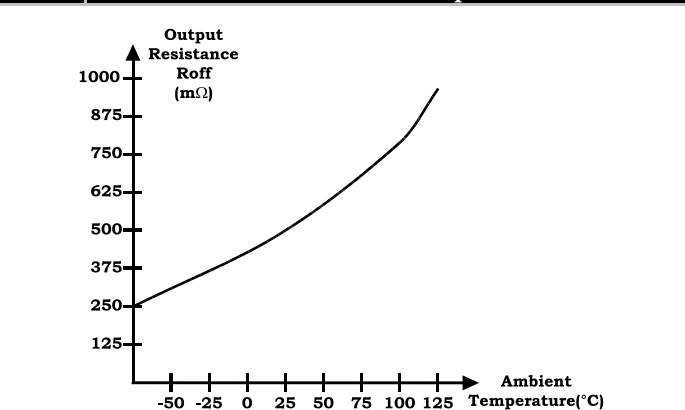

Fig. 11 Status Output Overvoltage Protection Characteristic

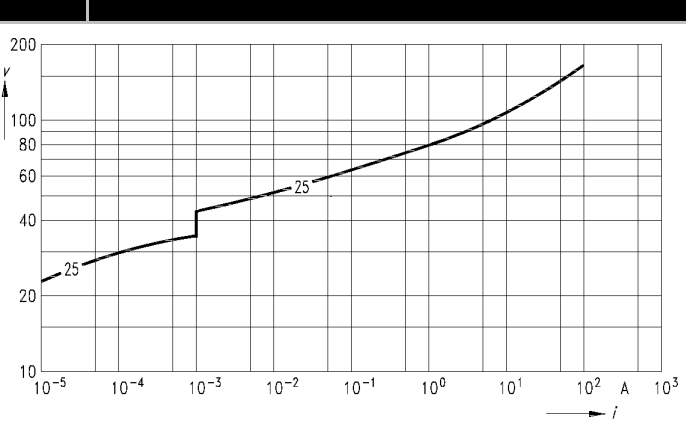
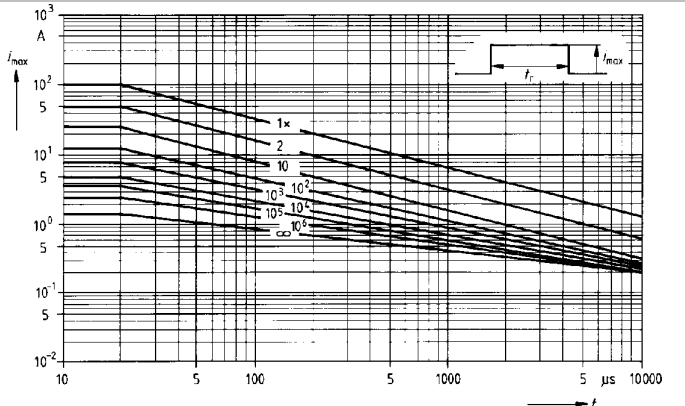

Fig. 12 Curve Giving The Max. Number Of Overload Pulses Regarding Their Duration For The Overvoltage Protection Of The Status Outputs



POWER**INTERNAL SUPPLY ELECTRICAL CHARACTERISTICS**

CHARACTERISTICS	LABELS	VALUES (Given at 20°C ambient unless otherwise specified)	REMARKS
Concerned Terminals		3L2 & 5L3	See internal diagram fig. 1 page 2
Voltage Range	Ue	200->480VAC	
Consumption	Is	1mA typical	
Frequency Range	f	40-65Hz	
Turn-on Time	tm	100ms	

POWER SIDE CHARACTERISTICS

CHARACTERISTICS	LABELS	VALUES (Given at 20°C ambient unless otherwise specified)	REMARKS
Concerned Terminals		1L1, 2T1, 3L2, 4T2, 5L3, 6T3	
Max Power Of The Motor @400VAC Star Wiring (Y)	Pn	7.5kW	
Max Power Of The Motor @230VAC Star Wiring (Y)	Pn	4.3kW	
Max Power Of The Motor @400VAC Delta Wiring (D)	Pn	13kW	Device wired inside the delta
Max Power Of The Motor @230VAC Delta Wiring (D)	Pn	7.5kW	Device wired inside the delta
Nom. Operating Voltage	Uen	230VAC & 400VAC	
Operating Voltage Range	Ue	200->480VAC	
Max. Non-repetitive Peak Voltage	Uep	1200V	
Integrated Overvoltage Protection		Yes 510V size 14 varistors	See curves fig. 16 & 17 page 7
AC53a Nom. Current according to EN60947-4-2 (Induction Motor)	Ie (AC53a)	11.5A (With heatsink)	Hard conditions See curve fig. 15 page 7
AC53a Max. Permanent Current (Induction Motor)	Ie (AC53a)	16A (With heatsink)	Normal conditions See curve fig. 15 page 7
Max. AC51 Permanent Current (Resistive Loads)	Ith (AC51)	75A (Limited at 50A by connections, with heatsink)	E.g. softstarting lamps
Non-repetitive Peak Overload Current (1 cycle of 10ms)	ITSM	1000A	See Curve fig. 14 page 7
Fusing Limit Current For Choosing The Protecting Fuses	I ² t	5000A ² s	@10ms
Min. Load Current	Iemin	100mA	
Max. Leakage Current	Ilk	7mA	@400VAC50Hz
Power Factor	Pf	0->1	
Operating Mains Frequency Range	F	40->65Hz	
Off-state Dv/Dt	dv/dt	500V/μs	
Integrated Transient Voltage Protection		YES RC network	
Max. Current Rising Time	di/dt	50A/μs	
Direct Voltage Drop Resistive Part	Ud	1.4V	@Ith
Of The Direct Voltage Drop Threshold Part	rt	6.5mΩ	@125°C
Of The Direct Voltage Drop	Vto	0.9V	@125°C
Max. Junction Temperature	Tjmax	125°C	
Junction/Plate Thermal Resistance Per Power Element	Rthjc	0.4K/W	Total = 3 power elements
Thermal Resistance without Heatsink Vertically Mounted	Rthca	4K/W	@ΔTca=60°C
Heatsink Thermal Time Constant	Tthca	15min	@ΔTca=60°C

CHARACTERISTIC CURVES OF THE POWER ELEMENTS

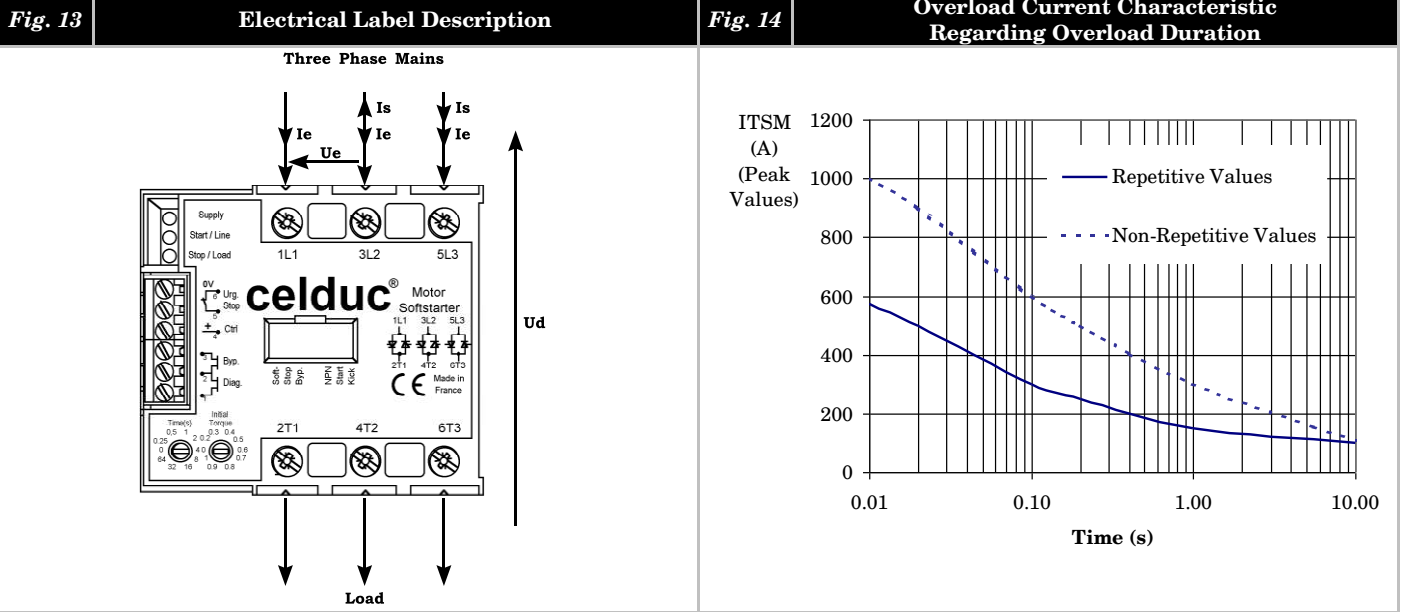
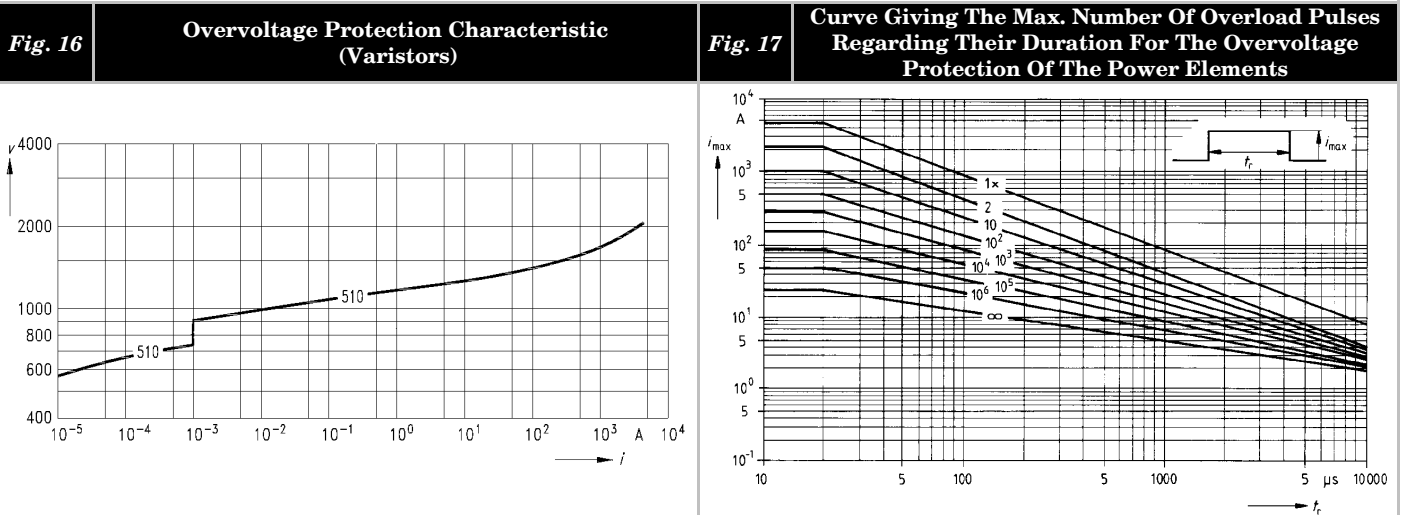

Fig. 15 Nominal Currents Versus Ambient Temperature

Not available



Solid State Relays For Motor Control

GENERAL

INPUT/OUTPUT ISOLATION CHARACTERISTIC

CHARACTERISTICS	LABELS	VALUES		REMARKS
		(Given at 20°C ambient unless otherwise specified)		
Power Output/Input Isolation	Uimp	4kV		
Status Outputs / Input Isolation	Uied	2.5kV		
Plate/Input Isolation	Uimp	4kV		
Status Output/Plate Isolation	Uimp	4kV		
Isolation Resistance	Rio	1GΩ		
Isolation Capacitance	Cio	<8pF		

CLIMATIC OPERATING ENVIRONMENT

CHARACTERISTICS	LABELS	VALUES		REMARKS
		(Given at 20°C ambient unless otherwise specified)		
Storage Ambient Temperature	Tstg	-40->+100°C		
Ambient Operating Temperature	Tamb	-40->+90°C		
Max. Heatsink Temperature	Tc	100°C		
Wet Heat Resistance (continuous)		According to I.E.C. 68 parts 2 & 3		
Wet Heat Resistance (cyclical)		According to I.E.C. 68 parts 2 & 30		

CONNEXIONS AND REQUIRED TOOLS ON THE CONTROL SIDE

CHARACTERISTICS	LABELS	VALUES		REMARKS
		(Given at 20°C ambient unless otherwise specified)		
Connections		Screwed		
Screwdriver		0.8 x 2mm		
Wire Cross Section		2.5mm ²		
Min. And Max. Tightening Torque				

CONNEXIONS AND REQUIRED TOOLS ON THE POWER SIDE

CHARACTERISTICS	LABELS	VALUES		REMARKS
		(Given at 20°C ambient unless otherwise specified)		
Connections		Screwed		
Screwdriver		Posidriv 2 or 0.8 x 5.5mm		
Wire Cross Section		1,5->6mm ² (10mm ² without ferrule)		
Min. And Max. Tightening Torque		1.8->3N.m		
Possible Number Of Connected Wires For The Max. Cross Section		2		

CHARACTERISTICS AND REQUIRED TOOLS FOR THE SETTINGS

CHARACTERISTICS	LABELS	VALUES		REMARKS
		(Given at 20°C ambient unless otherwise specified)		
Setting		"Time" and "Initial Torque"	Option Switches	Rotary switches : No rotation stop
Screwdriver				
Number Of Positions		10	2 for each switch	
Changing Position Required Torque		>1.5N.cm +/- 50%	>3N.cm +/- 50%	
Angle Between Each Position		36°	0°	

MISCELLANEOUS CHARACTERISTICS

CHARACTERISTICS	LABELS	VALUES		REMARKS
		(Given at 20°C ambient unless otherwise specified)		
Housing		UL94V0		
Mounting		Screwed		
Noise Level		Low audible vibration during the softstarting and softstopping periods		
Weight		1500g		

GENERAL

Fig. 18

DIMENSIONS

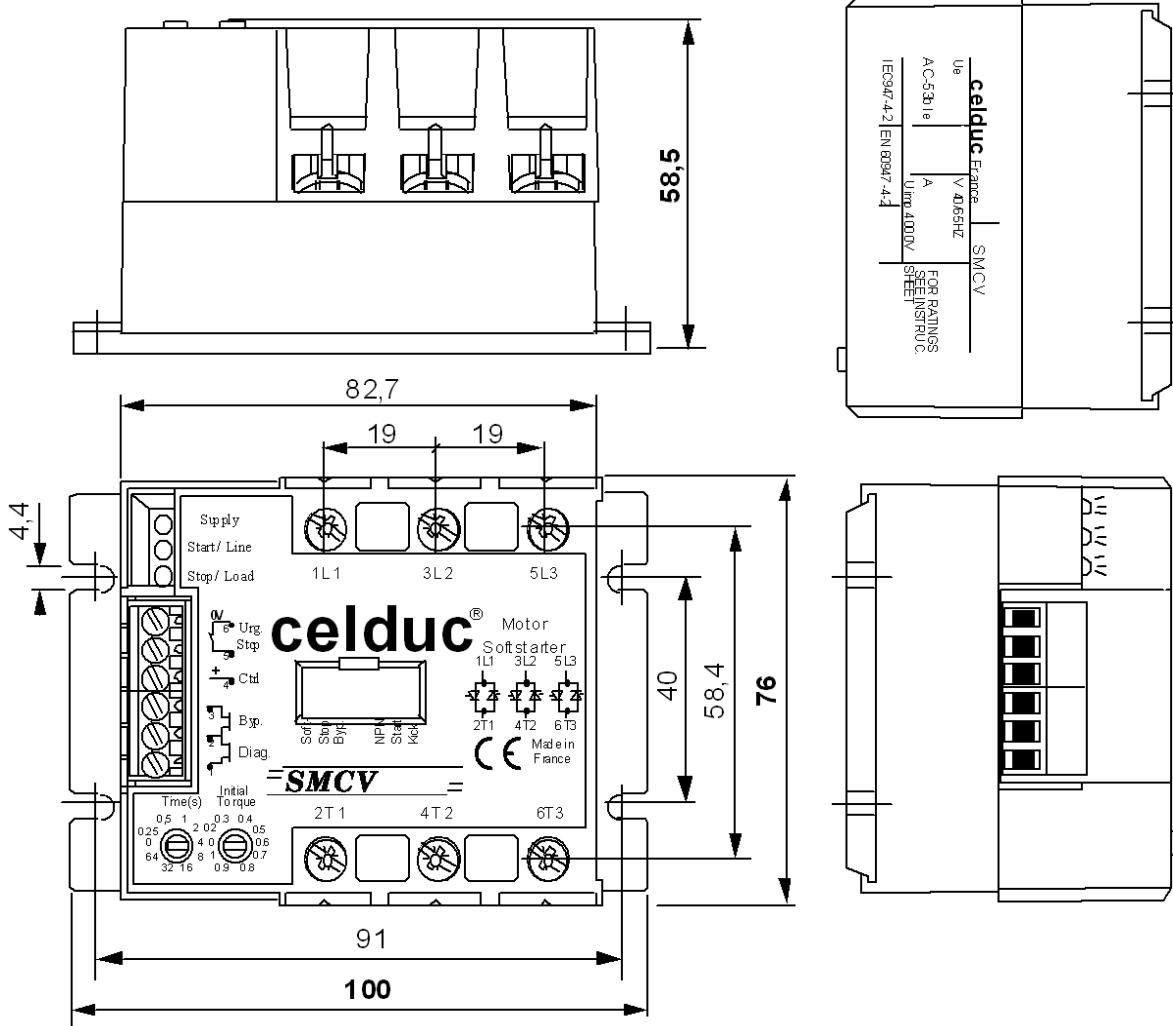

CHARACTERISTICS OF THE THERMAL PROTECTION

CHARACTERISTICS	LABELS	VALUES (Given at 20°C ambient unless otherwise specified)	REMARKS
-----------------	--------	--	---------

Not Available With This Reference

CHARACTERISTICS OF THE FAN

CHARACTERISTICS	LABELS	VALUES (Given at 20°C ambient unless otherwise specified)	REMARKS
-----------------	--------	--	---------

Not Available With This Reference

STANDARDS

IMMUNITY LEVEL WITHIN ELECTROMAGNETIC COMPATIBILITY (E.M.C.)

CHARACTERISTICS	LABELS	VALUES (Given at 20°C ambient unless otherwise specified)	REMARKS
Electrostatic discharges	EN 61000-4-2	8kV in the air 4kV contact	No state changing or destruction
Radiated Electromagnetic Fields	EN 61000-4-3	10V/m	No state changing or destruction
Fast Transient Bursts	EN 61000-4-4	2kV direct coupling on the power side 2kV clamped coupling on the input side	No state changing or destruction
Electric chocks	EN 61000-4-5	1kV direct coupling differential mode (Input and output sides) 2kV direct coupling common mode (Input and output sides)	No state changing or destruction
Voltage Drop	EN 61000-4-11		

EMISSION LEVEL WITHIN ELECTROMAGNETIC COMPATIBILITY (E.M.C.)

CHARACTERISTICS	LABELS	VALUES (Given at 20°C ambient unless otherwise specified)	REMARKS
Conducted Disturbances	EN55011	In compliance with the standards for industrial field In compliance with the standards for domestic field with an external bypass contactor	
Radiated Disturbances	EN55011	<30dbµV for the frequency range 30->230MHz <37dbµV for the frequency range 230->1000MHz	
Remarks Concerning Filtering		<p>The conducted or radiated disturbances generated by solid state relays depend on the wiring and load configuration.</p> <p>The test method recommended by the European standards and concerning electromagnetic compatibility leading to results far from reality, we decided to advise our customer in order to adapt their filtering scheme to their application.</p> <p>The European standard EN60947-4-2 requires the measurement to be done at full on state (end of the softstarting period). Therefore, our products are below the industrial field required levels on inductive load like the induction motor and no additional filter is needed.</p> <p>The starting period that may last several minutes generates enough interference to disturb sensitive devices located near the softstarter. If any, please contact us so that we can help you to choose the right filter.</p>	

LOW VOLTAGE DIRECTIVE

CHARACTERISTICS	LABELS	VALUES (Given at 20°C ambient unless otherwise specified)	REMARKS
Standard		EN60947-4-2	
Protection Level	IP	2L0	
Protection For Direct Touch		According to V.D.E. 160 part 100 : Back hand and finger safety	

APPROVALS

CHARACTERISTICS	LABELS	VALUES (Given at 20°C ambient unless otherwise specified)	REMARKS
CE Marking	EN 60947-4-2	Yes	
c UL US	UL508	Product built in compliance but not approved	
VDE 0805	EN60950	Product built in compliance but not approved	Office environment

INSTALLATION

IMPORTANT



DANGER!

The installation of this product must be done by qualified people, informed about electric hazards (electrocution risks linked to the voltage levels in the circuit).

Any intervention on the installation must be operated the circuit disconnected from the electric grid by an electromechanical mean insuring a sufficient galvanic isolation.

The device concerned by this document is composed of silicon based solid state switches. They never ensure a safe function when they are not controlled (Important leakage current and untimely closing). Therefore, we advise you to use an electromechanical device in series with the softstarter, which can ensure a safe operation in the disconnected circuit.

The emergency stop must not be done by the softstarter. It must be done by an electromechanical with sufficient current breaking possibility.

In order to operate in the circuit in safe condition, the control part of the softstarter will have to be disconnected from the control or auxiliary supplies as well.

ATTENTION

- 1- **The SMCV does not correctly operate on three phase mains with the motor neutral connected to the neutral of the mains. If any, please contact us.**
- 2- The overload relay must be adapted to the motor.
- 3- Please take care not to make short-circuits while installing the by-pass contactor or the backward wires for delta wiring.
- 4- In case of devices planned to be used connected to a by-pass contactor (SMCW...1 reference), the control voltage will have to be held sufficiently to allow the by-pass to close. Take care not to remove the by-pass checking option "byp."
- 5- In case of fast softstarting and softstopping controls without waiting for the end of the ramps, the motor may heat up. Please contact your motor supplier to choose an adapted model.

ENVIRONMENT OF THE SOFTSTARTER

DEVICES	LABELS	DESCRIPTION	REMARKS
On Line Fuses (Hard conditions according to EN60947-4-2)		FERRAZ 14 x 51 am 20/500V	
On Line Fuses (Normal conditions)		To be determine by the user	
Overload Relay (Hard conditions according to EN60947-4-2)		Moeller Z00-16 class 10A	
Overload Relay (Normal conditions)		To be determine by the user	
Breaking Capability Of The By-pass Contactor	KM1	16A AC1	
By-pass Contactor Coil	A1/A2	15VAm _{ax} . / 15W max.	
Thermal Protection	T°C	Not available	
Wiring / Settings		Comply with the characteristics given in general information	

INSTALLATION

WIRING POSSIBILITIES

Fig. 19

High Side Control (PNP)

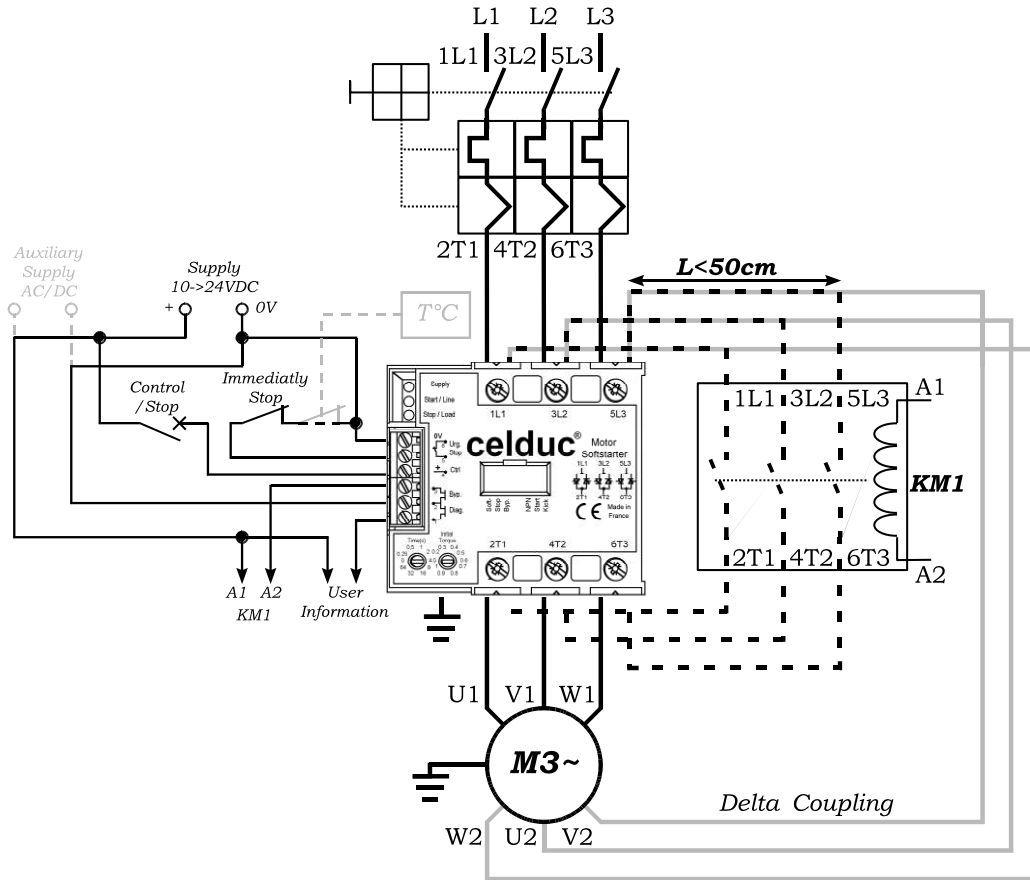
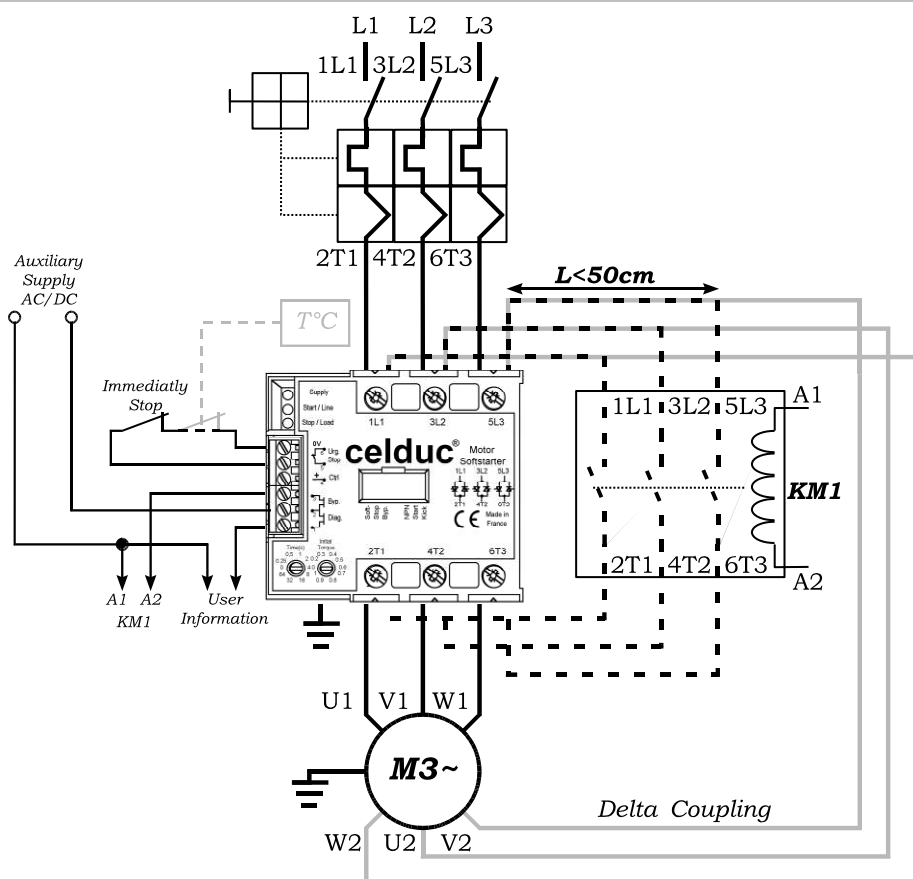

Fig. 20

Low Side Control (NPN)



INSTALLATION

WIRING POSSIBILITIES

Fig. 21

Upon The Mains Control

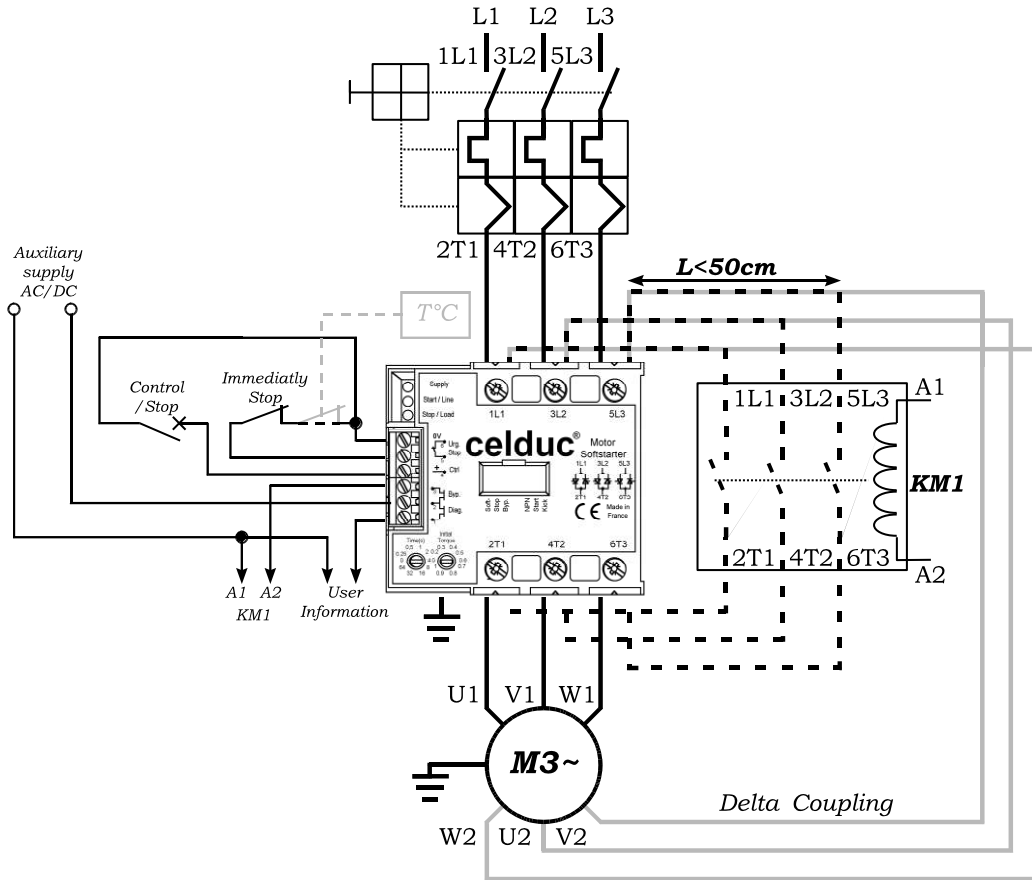

OTHER LOAD POSSIBILITIES

**Softstarting Incandescent Or Infrared Lamps
(AC1 Current)**

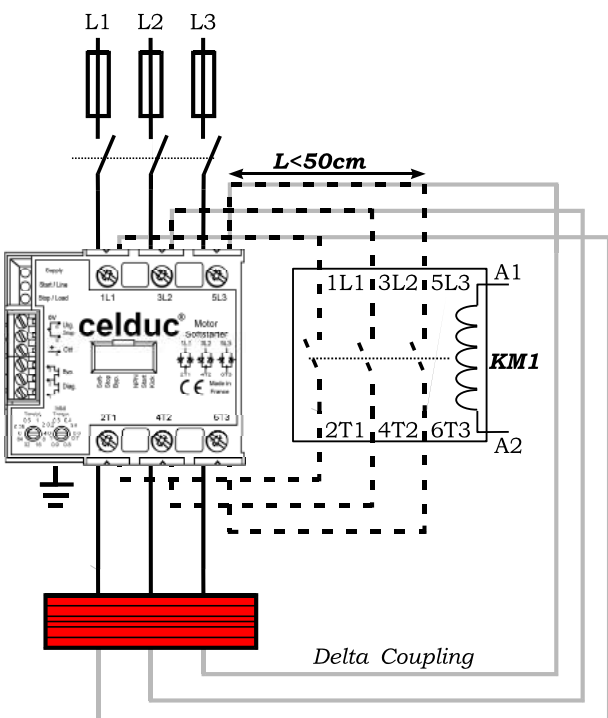

**Softstarting Three Phase Loaded Transformers
(Please consult us)**

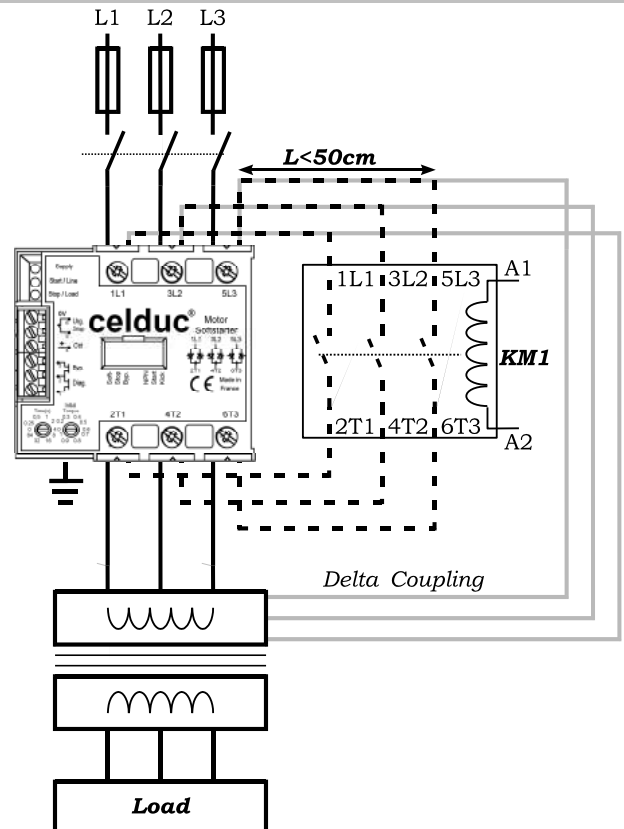

INSTALLATION

MOUNTING

Mounting Precautions :

The heatsink fins must be mounted vertically to ensure a good thermal convection.
A minimum space must be left free around the assembly.

Fig. 22

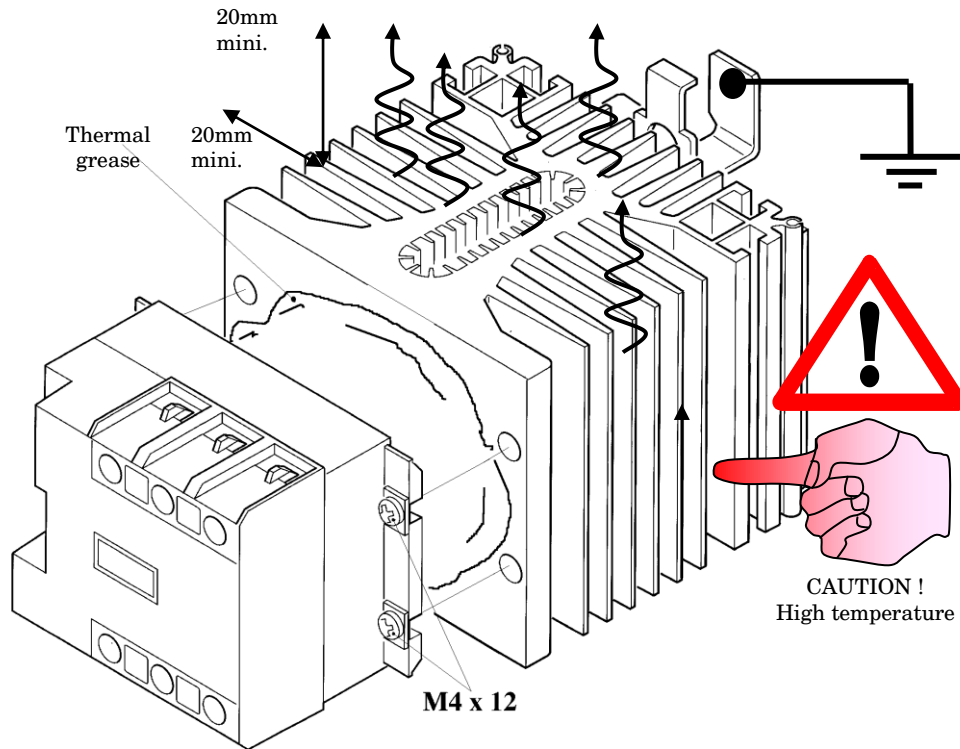

INSTALLATION

ADVISES FOR THE SETTINGS

ATTENTION

Obtaining a particular starting time value is only a consequence of the motor torque reduction and can not be guaranteed or easily repeatable. The rotary switch « Time (s) » setting values only give the duration of the voltage ramp applied to the motor but not necessarily its starting time. The main *SMCV* function is to obtain a motor torque reduction to take care of the motor load and the electric grid. The motor starting time is only a consequence and completely depends on the motor itself, its load and the settings done by the user.

The *SMCV* can not break a motor driving a load that has much inertia. The user can only obtain a stop time equal or longer than a simple disconnection from the electric grid. Using the softstop feature can only be justified when the motor load tends to break the motor (pumps, ...) or when the products treated by the machine need to be stop slowly (conveyors,...). In the case of load with high inertia, the softstop feature can help to reduce slowly the magnetic field inside the motor to avoid long time overvoltage in the circuit.

Setting Examples

Direct On Line Starting (DOL)	Long Starting Time For lamps, Transformers, ... (On a motor, it may hum)	Advise Settings For Testing The Motor Starting

**Loads With Increasing Torque Like N²
And Increasing Power Like N**

Load Examples	Advised Time Setting
Fans Centrifugal Pumps ...	Depending on the user starting time requirement
	Advised Torque Setting
Torque Curve	Adjusted to avoid the motor to hum
	Softstop
	½ of the starting time (Magnetic field reduction)

**Loads With Decreasing Torque Like 1/N
And Constant Power**

Load Examples	Advised Time Setting
Winding material around a shaft (cable, paper, metal, textile, plastic, ...) Chip disposal ...	Maximum (64s)
	Advised Torque Setting
Torque Curve	Depending on the user starting current requirement
	Softstop
	½ of the starting time (Magnetic field reduction)

**Loads with Constant Torque
And Power Increasing Like N**

Load Examples	Advised Time Setting
Conveyors, cranes, constant volume pumps, ...	Maximum (64s)
	Advised Torque Setting
Torque Curve	Depending on the user starting current requirement
	Softstop
	Depending on the user stopping smoothness requirement

**Loads Increasing Like N
And Constant Power**

Load Examples	Advised Time Setting
Machine tools, Rolling mills, ...	Depending on the user starting time requirement
	Advised Torque Setting
Torque Curve	Adjusted to avoid the motor to hum
	Softstop
	Depending on the user stopping smoothness requirement



www.celduc.com

5, rue Ampère B.P. 30004 42290 SORBIERS - FRANCE

Phone : +33 (0) 4 77 53 90 21 Fax : +33 (0) 4 77 53 85 51 Email : celduc-relais@celduc.com