

AC/DC Advanced Digital Power Controller for Single-Stage Dimmable LED Drivers

1 Description

The iW3688 is a single-stage, high-performance AC/DC off-line power supply controller for dimmable LED luminaires. It applies advanced digital control technology to detect the dimmer type, enabling it to provide dynamic impedance to interface with the dimmer and to control the LED brightness at the same time.

With advanced dimmer detection technology, the iW3688 can operate with most wall dimmers including leading-edge dimmers (R-type or R-L type), trailing-edge dimmers (R-C type), and smart dimmers. In addition, the iW3688's cycle-by-cycle waveform analysis technology allows for fast dimmer transient response.



In no-dimmer mode, the iW3688 operates the main power converter that delivers current to the LED load in quasi-resonant mode to provide high power efficiency and low electro-magnetic interference (EMI). When there is no dimmer on the line, the iW3688 optimizes the power factor and minimizes the current harmonic distortion to the AC line. The commonly utilized converter topologies for iW3688 are buck-boost and flyback.

The iW3688 uses patented PrimAccurate™ primary-side sensing technology to achieve excellent LED current regulation under different AC line and LED load voltages, without using a secondary-side feedback circuit and thus eliminating the need for an optocoupler.

The iW3688 minimizes the external components count by simplifying the EMI filter with Dialog's EZ-EMI® technology, and by integrating current sink, switching, and V_{CC} charging circuit. Additionally, the iW3688 does not require an auxiliary winding, which eliminates the need for a custom inductor. The digital control loop of the iW3688 maintains stability over all operating conditions without the need for loop compensation components.

The iW3688 maintains high performance wide-range dimming and achieves excellent dimmer compatibility with a simple application circuit.

2 Features

- Isolated/non-isolated off-line $120V_{AC}/230V_{AC}$ LED driver up to 20W output power
- Wide line frequency range (from 45Hz to 66Hz)
- Meets IEC61000-3-2 current harmonic requirement
- Total harmonic distortion < 20% with PF > 0.92
- Excellent dimmer compatibility
 - » Leading-edge dimmer
 - » Trailing-edge dimmer
 - » Digital smart dimmer
- Wide dimming range of 1% to 100%
- Intelligent digital control integrating current sink function into power switching circuit
- Advanced IC power management and voltage sensing enables the use of off-the-shelf inductor
- Resonant control to achieve high efficiency (typical > 85% without dimmer)
- Excellent AC line distortion immunity ensures quality of product under real-life circumstances
- Over-temperature LED current foldback and shutdown
- Tight LED current regulation ($\pm 5\%$)
- Fast start-up (< 0.5s without dimmer)
- Multiple protection features that include:
 - » LED open-circuit and short-circuit protection
 - » Current sensing resistor open circuit and short-circuit protection
 - » AC line over-voltage protection
 - » Over-current protection

3 Applications

- Dimmable LED retrofit lamps up to 20W
- Dimmable LED luminaires up to 20W



AC/DC Advanced Digital Power Controller for Single-Stage Dimmable LED Drivers

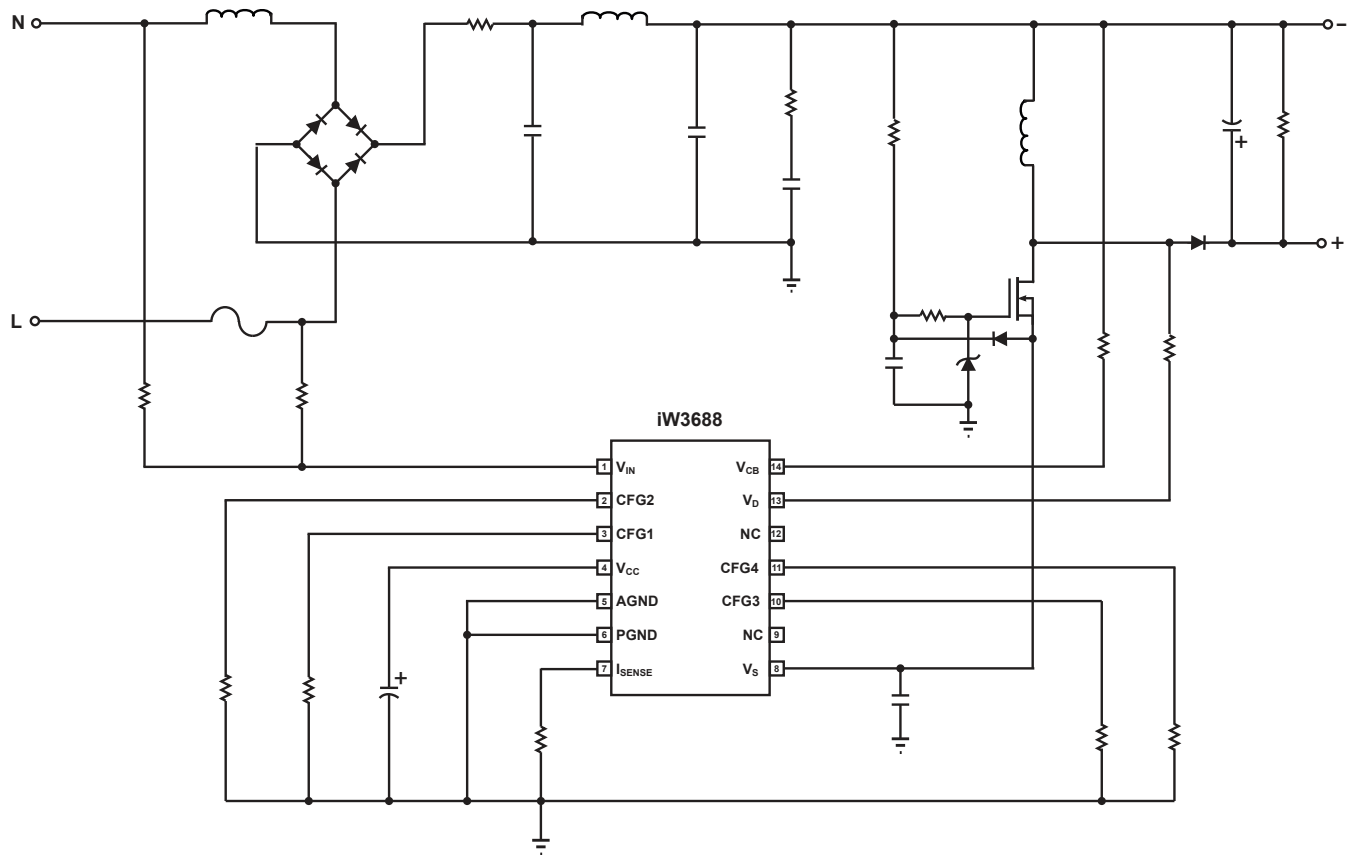

Figure 3.1 : iW3688 Simplified Application Circuit

AC/DC Advanced Digital Power Controller for Single-Stage Dimmable LED Drivers

4 Pinout Description

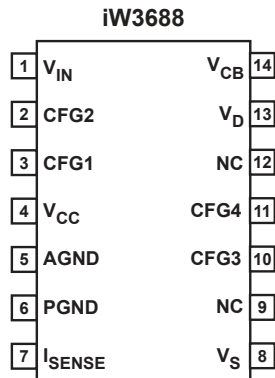

Figure 4.1 : 14-Lead SOIC-14 Package

Pin Number	Pin Name	Type	Pin Description
1	V _{IN}	Analog Input	Rectified AC line voltage input.
2	CFG2	Analog Input	Used for dimming mode configuration. See the applications section for additional information.
3	CFG1	Analog Input	Configures OTP threshold on start-up. See the applications section for configuration information.
4	V _{CC}	Power	Power supply for control logic.
5	AGND	Ground	Signal ground. It should be connected to the power ground on PCB.
6	PGND	Ground	Power ground.
7	I _{SENSE}	Analog Input	Current sense.
8	V _S	Analog Input	Source voltage of MOSFET.
9	NC	No Connection	Not internally connected.
10	CFG3	Analog Input	Used for dimming mode configuration. See the applications section for additional information.
11	CFG4	Analog Input	Used for dimming mode configuration. See the applications section for additional information.
12	NC	No Connection	Not internally connected.
13	V _D	Analog Input	Drain voltage of MOSFET.
14	V _{CB}	Analog Input	Input capacitor voltage after EMI filter.

AC/DC Advanced Digital Power Controller for Single-Stage Dimmable LED Drivers

5 Absolute Maximum Ratings

Absolute maximum ratings are the parameter values or ranges which can cause permanent damage if exceeded.

Parameter	Symbol	Value	Units
DC supply voltage range (pin 4)	V_{CC}	-0.3 to 6	V
V_{IN} input (pin 1)		-0.3 to 6	V
CFG1 input (pin 3)		-0.3 to 6	V
CFG2 input (pin 2)		-0.3 to 20	V
I_{SENSE} input (pin 7)		-0.3 to 6	V
V_S input (pin 8)		-0.3 to 20	V
CFG3 input (pin 10)		-0.3 to 6	V
CFG4 input (pin 11)		-0.3 to 20	V
V_D input voltage (pin 13)		-0.3 to 6	V
V_{CB} input voltage (pin 14)		-0.3 to 6	V
Maximum V_D input current (pin 13)	$I_{IN(VD)}$	750	μA
Maximum V_{CB} input current (pin 14)	$I_{IN(VCB)}$	750	μA
Maximum junction temperature	T_{JMAX}	150	$^{\circ}C$
Operating junction temperature	T_{JOPT}	-40 to 150	$^{\circ}C$
Storage temperature	T_{STG}	-65 to 150	$^{\circ}C$
Thermal resistance junction-to-PCB [gnd lead]	ψ_{JB}	45	$^{\circ}C/W$
ESD rating per JEDEC JESD22-A114		$\pm 1,000$	V
Latch-up test per JESD78A		± 100	mA

AC/DC Advanced Digital Power Controller for Single-Stage Dimmable LED Drivers

6 Physical Dimensions

14-Lead SOIC Package

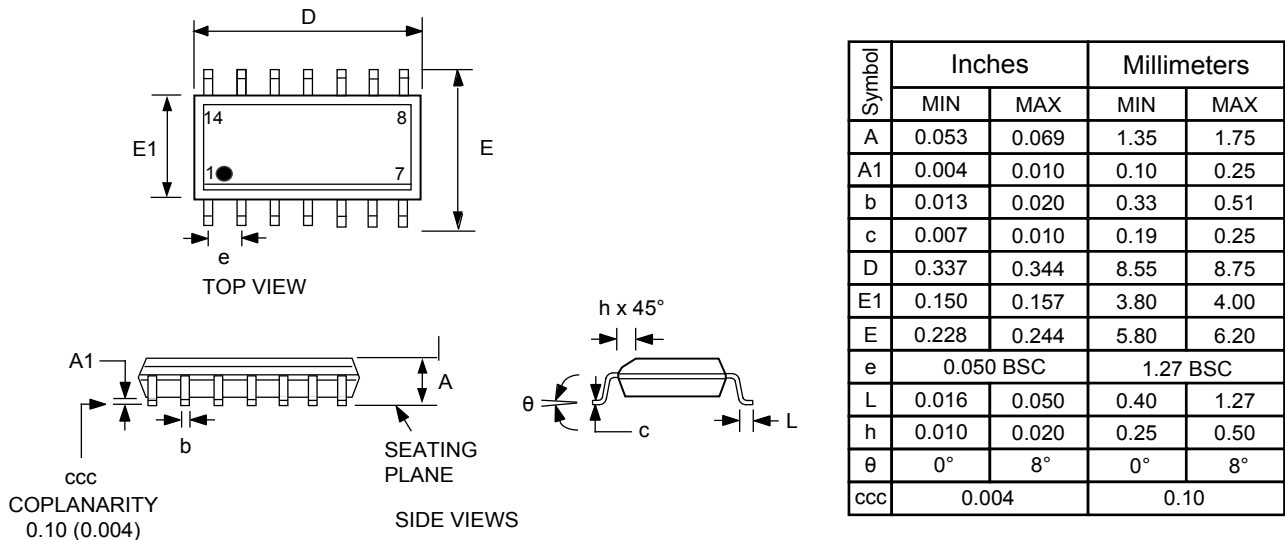

Compliant to JEDEC Standard MS12F

Controlling dimensions are in inches; millimeter dimensions are for reference only

This product is RoHS compliant and Halide free.

Soldering Temperature Resistance:

[a] Package is IPC/JEDEC Std 020D Moisture Sensitivity Level 1

[b] Package exceeds JEDEC Std No. 22-A111 for Solder Immersion Resistance; package can withstand 10 s immersion < 260°C

Dimension D does not include mold flash, protrusions or gate burrs. Mold flash, protrusions or gate burrs shall not exceed 0.15 mm per end. Dimension E does not include interlead flash or protrusion. Interlead flash or protrusion shall not exceed 0.25 mm per side.

The package top may be smaller than the package bottom. Dimensions D and E are determined at the outermost extremes of the plastic body exclusive of mold flash, tie bar burrs, gate burrs and interlead flash, but including any mismatch between the top and bottom of the plastic body.

Figure 6.1 : 14-Lead SOIC Package

7 Ordering Information

Part No.	Options	Package	Description
iW3688-00	120V _{AC} Input for up to 14W	SOIC-14	Tape & Reel ¹
iW3688-01	230V _{AC} Input for up to 14W	SOIC-14	Tape & Reel ¹
iW3688-01-CA	230V _{AC} Input with lighting chopping enable for thermal improvement up to 20W	SOIC-14	Tape & Reel ¹
iW3688-10	120V _{AC} Input with light chopping enabled for thermal improvement up to 20W	SOIC-14	Tape & Reel ¹
iW3688-20	120V _{AC} Input for 15W – 20W	SOIC-14	Tape & Reel ¹
iW3688-21	230V _{AC} Input for 15W – 20W	SOIC-14	Tape & Reel ¹
iW3688-30	Universal Input for up to 14W	SOIC-14	Tape & Reel ¹

Note 1: Tape & Reel packing quantity is 2,500/reel. Minimum ordering quantity is 2,500.

AC/DC Advanced Digital Power Controller for Single-Stage Dimmable LED Drivers

IMPORTANT NOTICE AND DISCLAIMER

RENESAS ELECTRONICS CORPORATION AND ITS SUBSIDIARIES ("RENESAS") PROVIDES TECHNICAL SPECIFICATIONS AND RELIABILITY DATA (INCLUDING DATASHEETS), DESIGN RESOURCES (INCLUDING REFERENCE DESIGNS), APPLICATION OR OTHER DESIGN ADVICE, WEB TOOLS, SAFETY INFORMATION, AND OTHER RESOURCES "AS IS" AND WITH ALL FAULTS, AND DISCLAIMS ALL WARRANTIES, EXPRESS OR IMPLIED, INCLUDING, WITHOUT LIMITATION, ANY IMPLIED WARRANTIES OF MERCHANTABILITY, FITNESS FOR A PARTICULAR PURPOSE, OR NON-INFRINGEMENT OF THIRD PARTY INTELLECTUAL PROPERTY RIGHTS.

These resources are intended for developers skilled in the art designing with Renesas products. You are solely responsible for (1) selecting the appropriate products for your application, (2) designing, validating, and testing your application, and (3) ensuring your application meets applicable standards, and any other safety, security, or other requirements. These resources are subject to change without notice. Renesas grants you permission to use these resources only for development of an application that uses Renesas products. Other reproduction or use of these resources is strictly prohibited. No license is granted to any other Renesas intellectual property or to any third party intellectual property. Renesas disclaims responsibility for, and you will fully indemnify Renesas and its representatives against, any claims, damages, costs, losses, or liabilities arising out of your use of these resources. Renesas' products are provided only subject to Renesas' Terms and Conditions of Sale or other applicable terms agreed to in writing. No use of any Renesas resources expands or otherwise alters any applicable warranties or warranty disclaimers for these products.

© 2022 Renesas Electronics Corporation. All rights reserved.

RoHS Compliance

Dialog Semiconductor's suppliers certify that its products are in compliance with the requirements of Directive 2011/65/EU of the European Parliament on the restriction of the use of certain hazardous substances in electrical and electronic equipment. RoHS certificates from our suppliers are available on request.

(Rev.1.0 Mar 2020)

Corporate Headquarters

TOYOSU FORESIA, 3-2-24 Toyosu
Koto-ku, Tokyo 135-0061, Japan
www.renesas.com

Contact Information

For further information on a product, technology, the most up-to-date version of a document, or your nearest sales office, please visit:
www.renesas.com/contact/

Trademarks

Renesas and the Renesas logo are trademarks of Renesas Electronics Corporation. All trademarks and registered trademarks are the property of their respective owners.