

LOC		DIST		REVISIONS			
P	LTR	DESCRIPTION	DATE	DN	APVD		
U	REV PER ECO	15-016251	11-12-15	CT	CD		

- THIS RECEPTACLE WILL MATE WITH ANY 24C7, SIZE 5 PLUG IN AMPLIMITE SERIES.
 - MAXIMUM WIRE INSULATION TO BE USED WITH THIS RECEPTACLE IS $\phi .068$.
 - THIS CONNECTOR ACCEPTS (7) POWER 8, OR COAX SOCKET CONTACTS IN POSITIONS A1 THRU A7, PURCHASED SEPARATELY.
 - THIS CONNECTOR ACCEPTS SIZE 20 SOCKET CONTACTS IN POSITIONS 1 THRU 17, PURCHASED SEPARATELY.
- 5 UL/CSA DESIGNATION STAMPED IN THIS AREA, OPTIONAL.
 - 6 MATERIAL: STEEL PER ASTM-A-109.
 - 7 MATERIAL: BRASS PER MIL-C-50 AND ASTM-B-36 UNS NO. C26000.
 - 8 FINISH: TIN PER ASTM-B-545 .000400 MIN THK OVER COPPER PER AMS2418 .000050 MIN THK.
 - 9 FINISH: CADMIUM PLATED PER QQ-P-416.
 - 10 FINISH: GOLD PER MIL-G-45204 TYPE II, GRADE C, CLASS 1 OVER COPPER PER MIL-C-14550, CLASS IV.
 - 11 INK STAMP WESTINGHOUSE PART NO. 97942-645A935H03, FAR SIDE.
 - 12 FINISH: ZINC PLATE PER ASTM-B-633, .000200-.000400 THK WITH SUPPLEMENTARY CHROMATE (Cr3+)

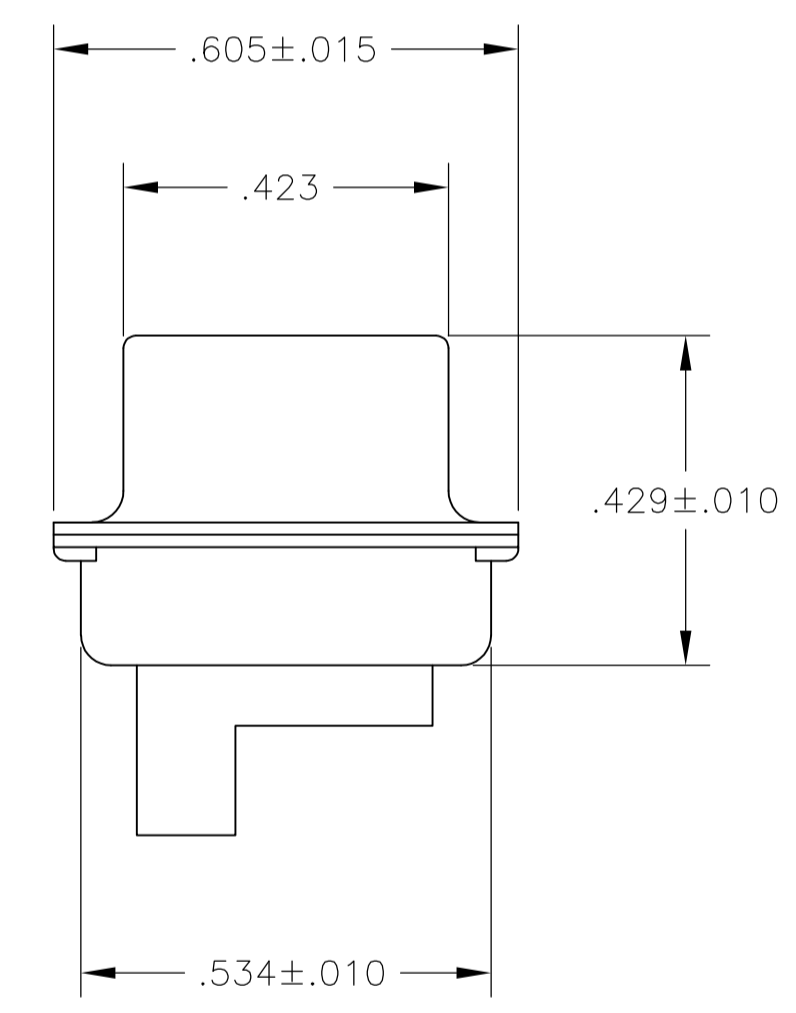
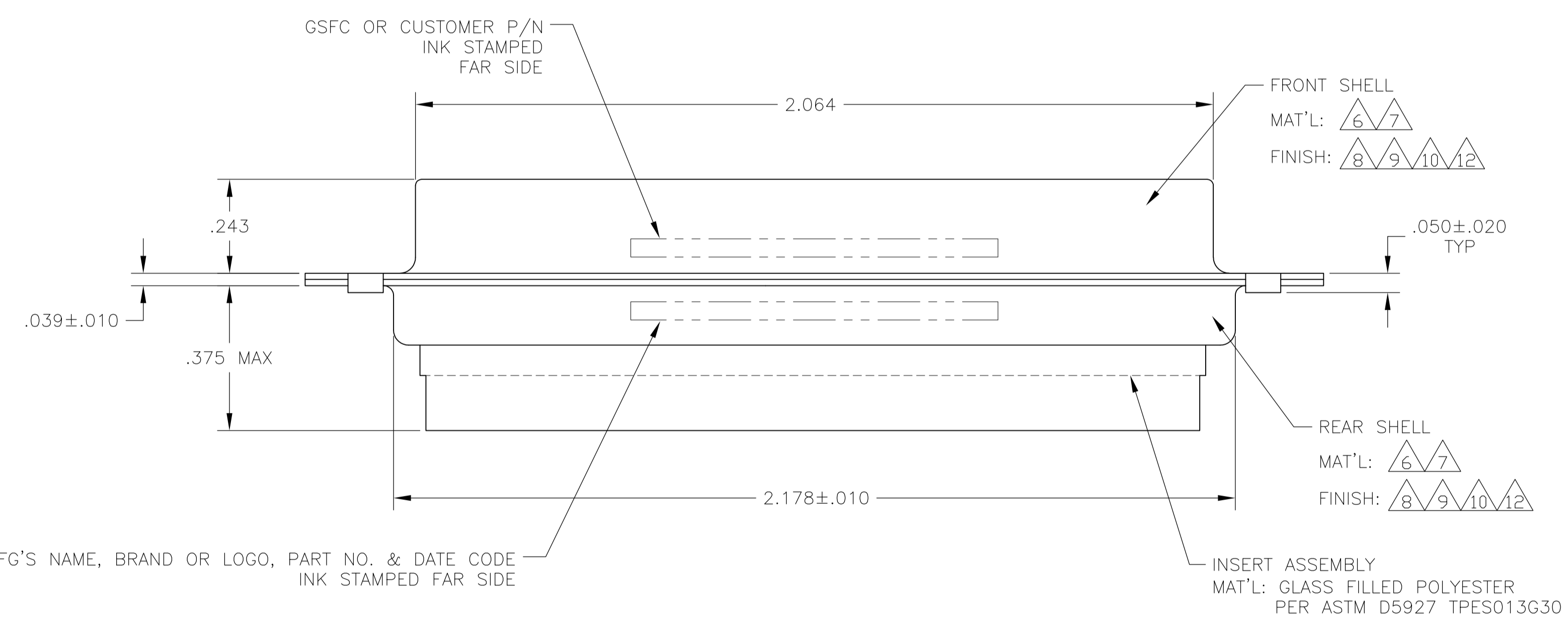
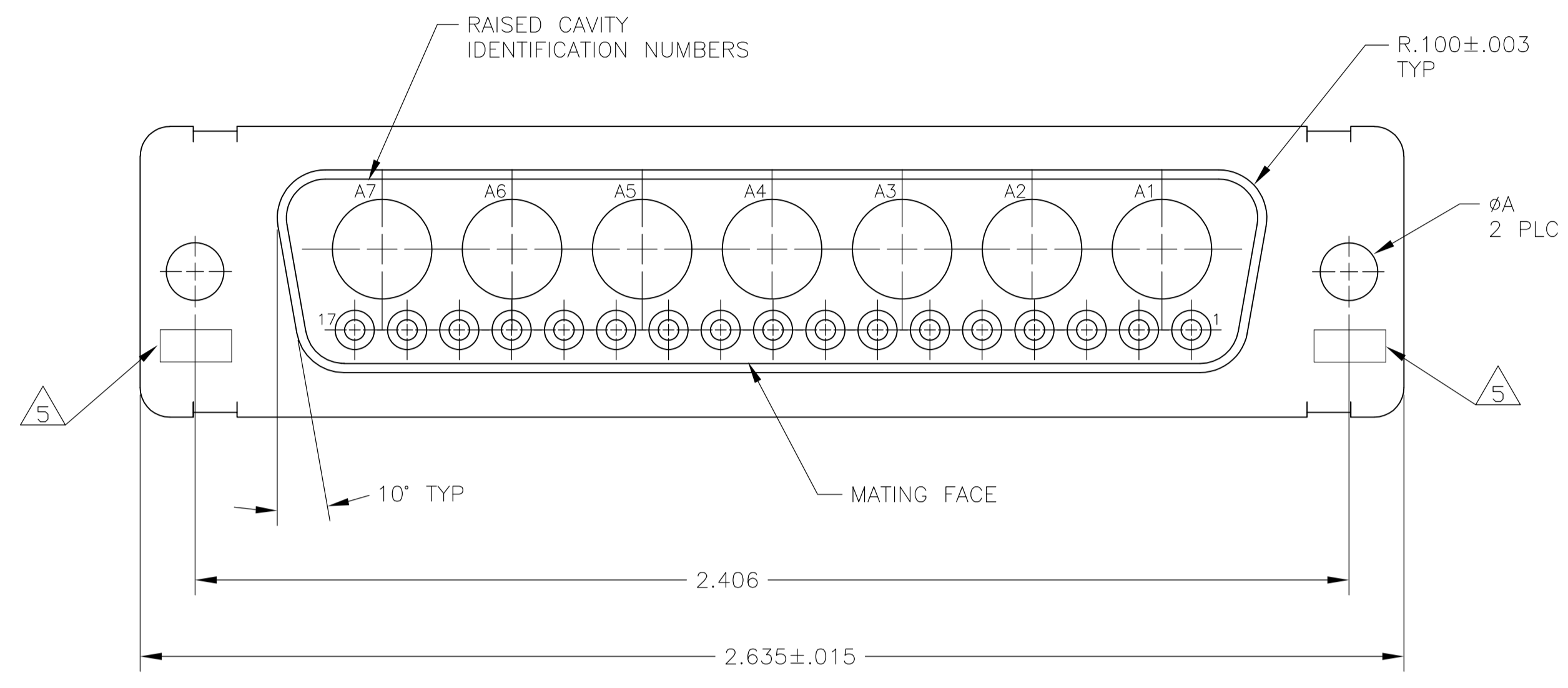

6 8	.120	-	5-208552-4
6 12	.120	-	5-208552-1
6 9	.120	T5935-0103-006	208552-7
6 8	.120	-	208552-6
7 10	.154	311P405-22S-B-15	208552-5
6 8	.120	-	208552-4
6 9 11	.120	97942-645A935H03	208552-3
7 10	.120	311P405-22S-B-12	208552-2
6 9	.120	-	208552-1
REMARKS	øA	CUSTOMER PART NO.	PART NO.

THIS DRAWING IS A CONTROLLED DOCUMENT.

DIMENSIONS: INCHES	TOLERANCES UNLESS OTHERWISE SPECIFIED:	DIN T. SHUEY 07-JAN-88	TE Connectivity
0 PLC ± -	1 PLC ± -	CHK A. EMADI 27-JAN-88	RECEPTACLE ASSEMBLY
2 PLC ± -	3 PLC ± .005(0.13)	APVD A. EMADI 27-JAN-88	AMPLIMITE 24C7
4 PLC ± -	ANGLES ± # 0'30'	NAME	SIZE 5, COAX MIX
MATERIAL	FINISH	SIZE	CAGE CODE
		A1	00779
		WEIGHT	208552
		CUSTOMER DRAWING	SCALE 4:1 SHEET 1 OF 1 REV U