

ISOVIEW

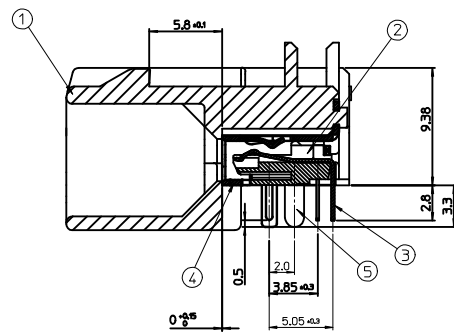

SECTION Z-Z

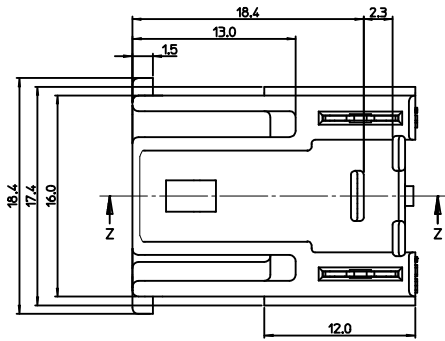
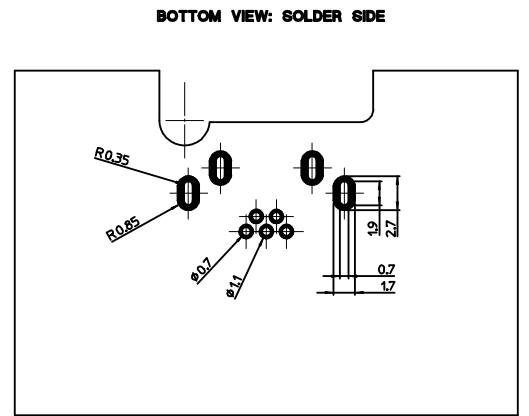
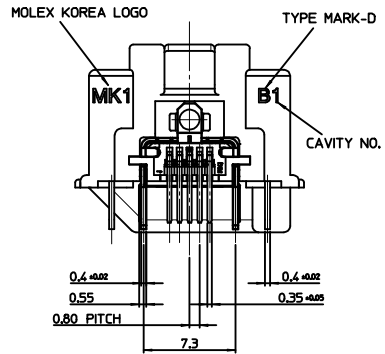
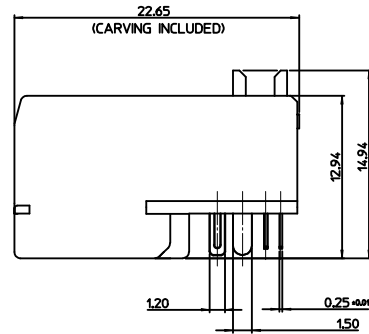
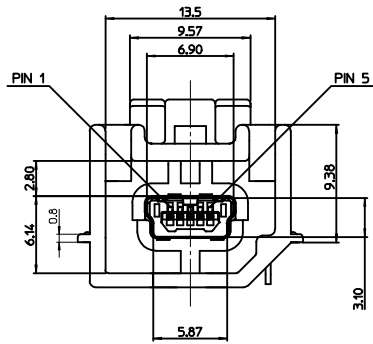
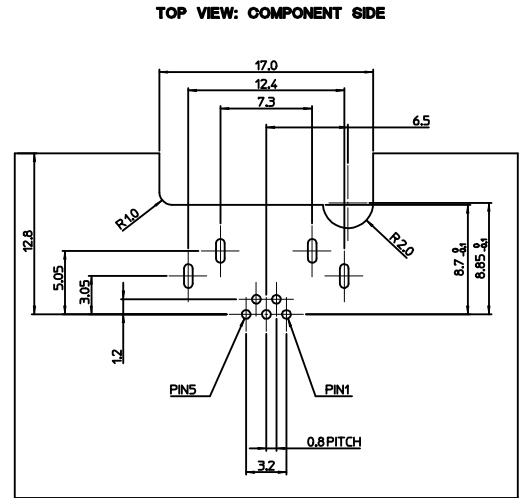

NOTES

- MATES WITH :
(MOLEX SERIES NO. : 111014, 111015, 111005, 111041, 111019, 111020)
- SHROUD GEOMETRY AND ASSEMBLY WITH USB MINI-B CONNECTOR ARE ACCORDING TO USCAR STD 999-U-USB-Z01
- FINISHES
- TERMINAL :
CONTACT AREA : GOLD 0.75μm MIN.
SOLDER TAIL AREA : TIN 3.84μm MIN.
UNDER PLATING : NI 1.25μm MIN.
- SHIELD CASE :
3.04μm MIN. TIN OVER NI 1.04μm MIN.
- FITTING NAIL :
3.04μm MIN. TIN OVER NI 1.04μm MIN.
- UNLESS OTHERWISE SPECIFIED, TYPICAL RECOMMENDED PCB MANUFACTURING TOLERANCE IS ±0.05
- PCB THICKNESS : 1.6mm(REFERENCE)

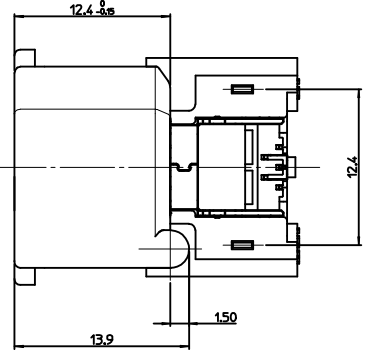

<PART LIST>

NO.	PART NAME	MATERIALS
①	SHROUD	SPS, GLASS FILLED, UL94 HB
②	REC. HOUSING	LCP, GLASS FILLED, UL94 V-0
③	TERMINAL	COPPER ALLOY
④	SHIELD CASE	PHOSPHOR BRONZE
⑤	FITTING NAIL	BRASS

<TABLE 1>

MATERIAL NO.	ORDER NO.	COLOR
1040870505	104087-0505	GRAY

NEW RELEASED EEC NO: K1R2017-0005 DRAWING: MK1M02 2016/07/16 CHKD: APPR: JIJIANG 2016/08/25	QUALITY SYMBOLS ▽=0 ▽=0	GENERAL TOLERANCES (UNLESS SPECIFIED) mm INCH 4 PLACES ± --- ± --- 3 PLACES ± --- ± --- 2 PLACES ± 0.15 ± --- 1 PLACE ± 0.25 ± --- ANGULAR ± 3°	DIMENSION STYLE MM ONLY	SCALE 1:1	DESIGN UNITS METRIC	THIRD ANGLE PROJECTION	
	DRAWN BY JWK1M02	DATE 2016/07/16	CHECKED BY	DATE	TITLE HSAUTOLINK R/A HEADER TYPE B (SIDE WING)	MOLEX INCORPORATED	SHEET NO. 1 OF 1
	APPROVED BY JHJANG	DATE 2016/08/25	MATERIAL NO. SD-104087-018	DOCUMENT NO.	SEE TABLE 1	THIS DRAWING CONTAINS INFORMATION THAT IS PROPRIETARY TO MOLEX INCORPORATED AND SHOULD NOT BE USED WITHOUT WRITTEN PERMISSION	1
	DRAFT WHERE APPLICABLE MUST REMAIN WITHIN DIMENSIONS						

RECOMMENDED PCB LAYOUT

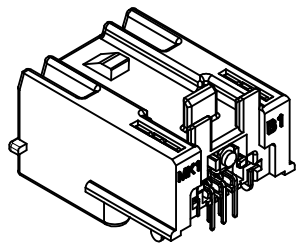

ISOVIEW

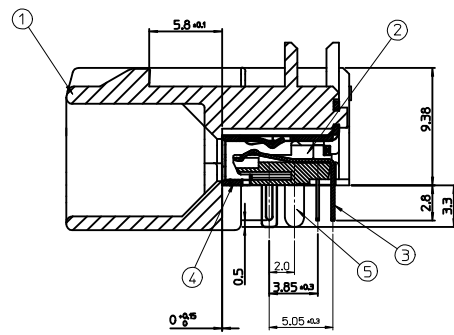
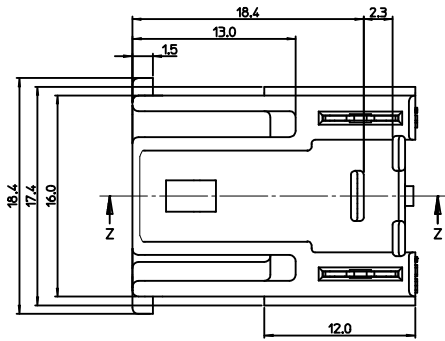

SECTION Z-Z

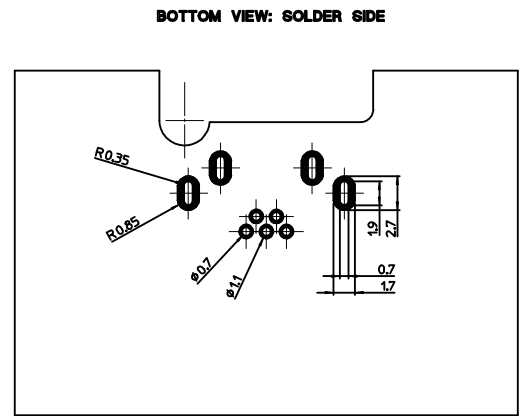
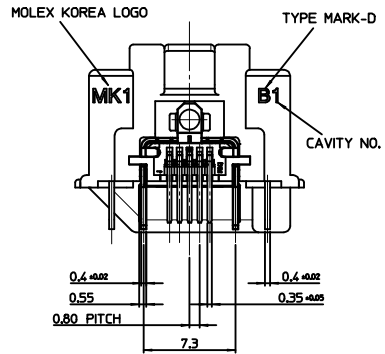
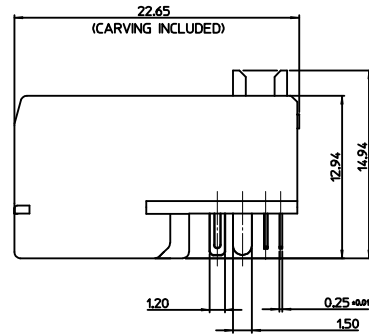
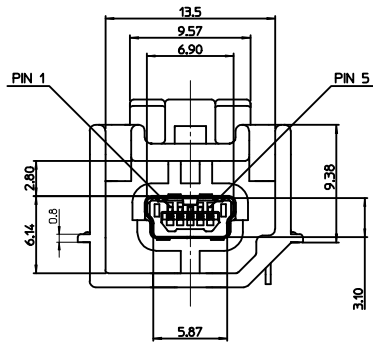
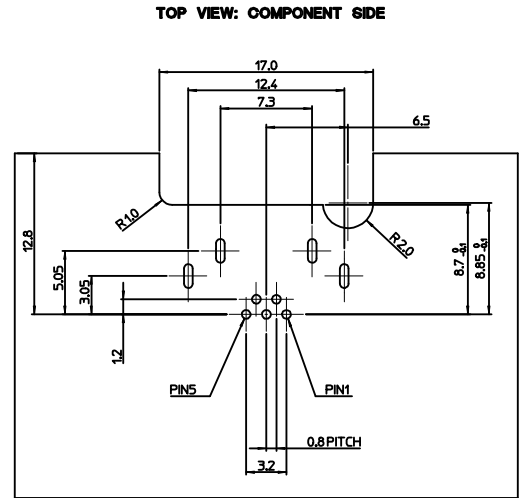

- NOTES
- MATES WITH :
(MOLEX SERIES NO. : 111014, 111015, 111005, 111041, 111019, 111020)
 - SHROUD GEOMETRY AND ASSEMBLY WITH USB MINI-B CONNECTOR ARE ACCORDING TO USCAR STD 999-U-USB-Z01
 - FINISHES
 - TERMINAL :
CONTACT AREA : GOLD 0.75μm MIN.
SOLDER TAIL AREA : TIN 3.84μm MIN.
UNDER PLATING : NI 1.25μm MIN.
 - SHIELD CASE :
3.04μm MIN. TIN OVER NI 1.04μm MIN.
 - FITTING NAIL :
3.04μm MIN. TIN OVER NI 1.04μm MIN.
 - UNLESS OTHERWISE SPECIFIED, TYPICAL RECOMMENDED PCB MANUFACTURING TOLERANCE IS ±0.05
 - PCB THICKNESS : 1.6mm(REFERENCE)

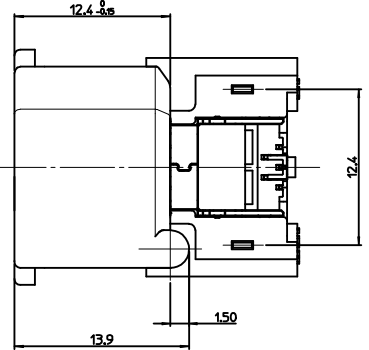

<PART LIST>

NO.	PART NAME	MATERIALS
①	SHROUD	SPS, GLASS FILLED, UL94 HB
②	REC. HOUSING	LCP, GLASS FILLED, UL94 V-0
③	TERMINAL	COPPER ALLOY
④	SHIELD CASE	PHOSPHOR BRONZE
⑤	FITTING NAIL	BRASS

<TABLE 1>

MATERIAL NO.	ORDER NO.	COLOR
1040870505	104087-0505	GRAY

NEW RELEASED EEC NO: K1R2017-0005 DRAWING: MK1M02 2016/07/16 CHKD: APPR: JIJIANG 2016/08/25	QUALITY SYMBOLS ▽=0 ▽=0	GENERAL TOLERANCES (UNLESS SPECIFIED) <table border="1"> <tr> <th></th> <th>mm</th> <th>INCH</th> </tr> <tr> <td>4 PLACES</td> <td>±---</td> <td>±---</td> </tr> <tr> <td>3 PLACES</td> <td>±---</td> <td>±---</td> </tr> <tr> <td>2 PLACES</td> <td>±0.15</td> <td>±---</td> </tr> <tr> <td>1 PLACE</td> <td>±0.25</td> <td>±---</td> </tr> </table> ANGULAR ± 3°		mm	INCH	4 PLACES	±---	±---	3 PLACES	±---	±---	2 PLACES	±0.15	±---	1 PLACE	±0.25	±---	DIMENSION STYLE MM ONLY	SCALE 1:1	DESIGN UNITS METRIC	THIRD ANGLE PROJECTION
		mm	INCH																		
	4 PLACES	±---	±---																		
	3 PLACES	±---	±---																		
2 PLACES	±0.15	±---																			
1 PLACE	±0.25	±---																			
DRAWN BY JWK1M02	DATE 2016/07/16	CHECKED BY DATE	TITLE HSAUTOLINK R/A HEADER TYPE B (SIDE WING)	APPROVED BY JHJANG	DATE 2016/08/25	MOLEX INCORPORATED															
MATERIAL NO. SEE TABLE 1	DOCUMENT NO. SD-104087-018	SHEET NO. 1 OF 1	THIS DRAWING CONTAINS INFORMATION THAT IS PROPRIETARY TO MOLEX INCORPORATED AND SHOULD NOT BE USED WITHOUT WRITTEN PERMISSION																		

RECOMMENDED PCB LAYOUT