

Bipolar stepper motor driver expansion board based on the L6208 for STM32 Nucleo

Data brief

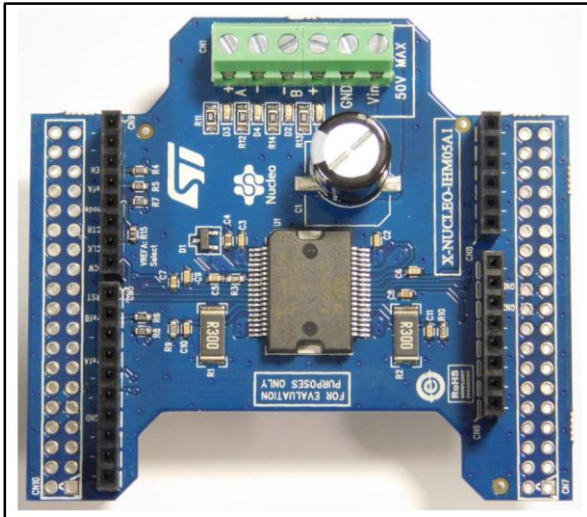

Description

The X-NUCLEO-IHM05A1 is a bipolar stepper motor driver expansion board based on the L6208 driver for bipolar stepper motors. It provides an affordable and easy-to-use solution for driving bipolar stepper motors in STM32 Nucleo projects. The X-NUCLEO-IHM05A1 is compatible with the Arduino UNO R3 connector, and supports the addition of other STM32 expansion boards with a single STM32 Nucleo board. The user can also mount the ST Morpho connector.

Features

- Voltage range: 8 V to 50 V
- Phase current: up to 2.8 A r.m.s.
- Dual independent PWM current controllers
- Fast and slow decay mode selection
- Decoding logic for stepper motors, full and half step drives
- Overcurrent protection
- Thermal protection shutdown
- Compatible with Arduino UNO R3 connector
- Compatible with STM32 Nucleo boards
- RoHS compliant



1 Schematic diagram

Figure 1: X-NUCLEO-IHM05A1 circuit schematic

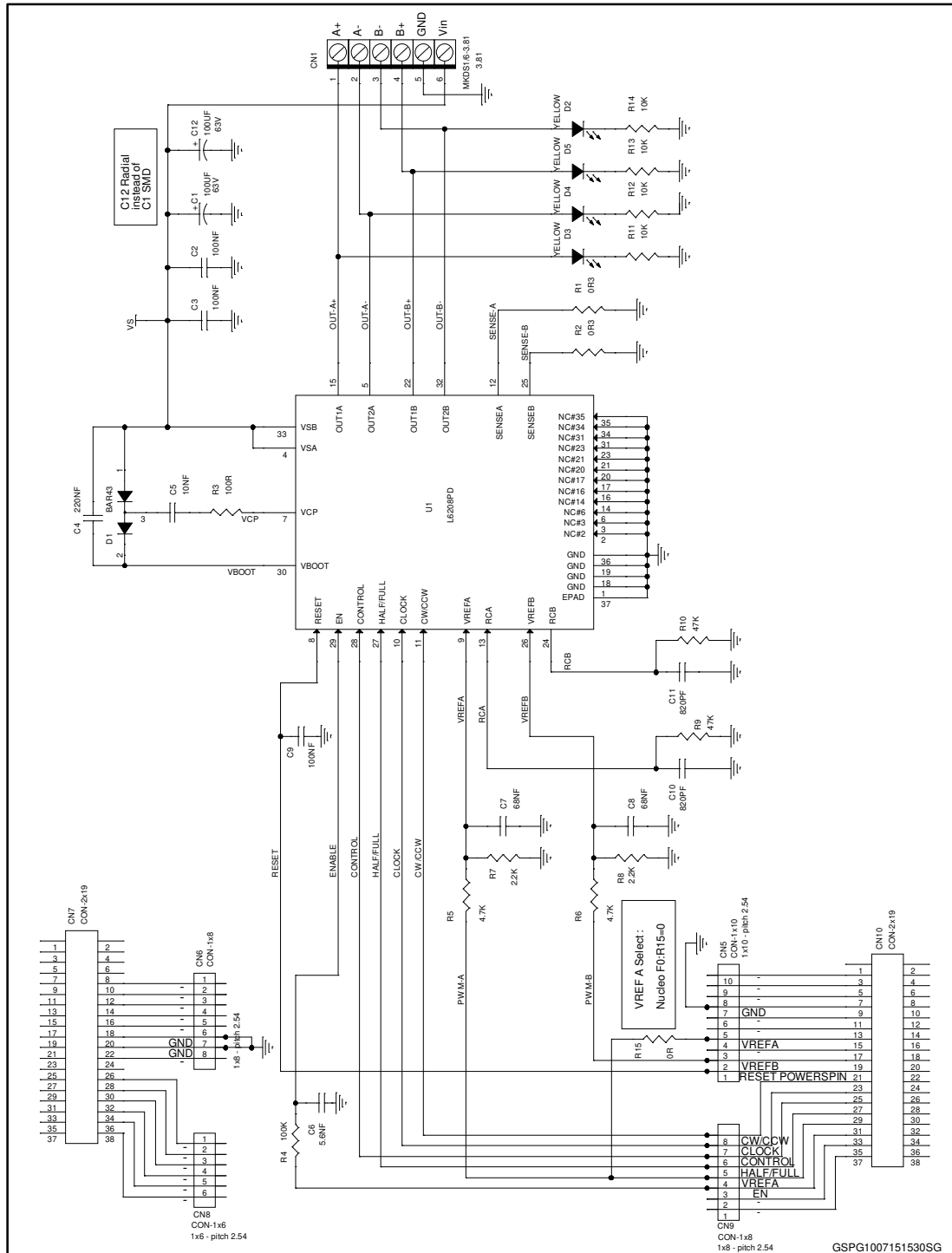

2 Revision history

Table 1: Document revision history

Date	Version	Changes
17-Jul-2015	1	Initial release.

IMPORTANT NOTICE – PLEASE READ CAREFULLY

STMicroelectronics NV and its subsidiaries (“ST”) reserve the right to make changes, corrections, enhancements, modifications, and improvements to ST products and/or to this document at any time without notice. Purchasers should obtain the latest relevant information on ST products before placing orders. ST products are sold pursuant to ST’s terms and conditions of sale in place at the time of order acknowledgement.

Purchasers are solely responsible for the choice, selection, and use of ST products and ST assumes no liability for application assistance or the design of Purchasers’ products.

No license, express or implied, to any intellectual property right is granted by ST herein.

Resale of ST products with provisions different from the information set forth herein shall void any warranty granted by ST for such product.

ST and the ST logo are trademarks of ST. All other product or service names are the property of their respective owners.

Information in this document supersedes and replaces information previously supplied in any prior versions of this document.

© 2015 STMicroelectronics – All rights reserved