

used for: D-SUB COMBINATION

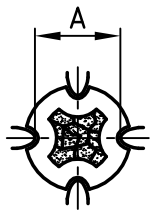

Selector settings	Crimp height A
7 for AWG 20	0.87 - 0.98
6 for AWG 22	0.77 - 0.88
5 for AWG 24	0.67 - 0.78

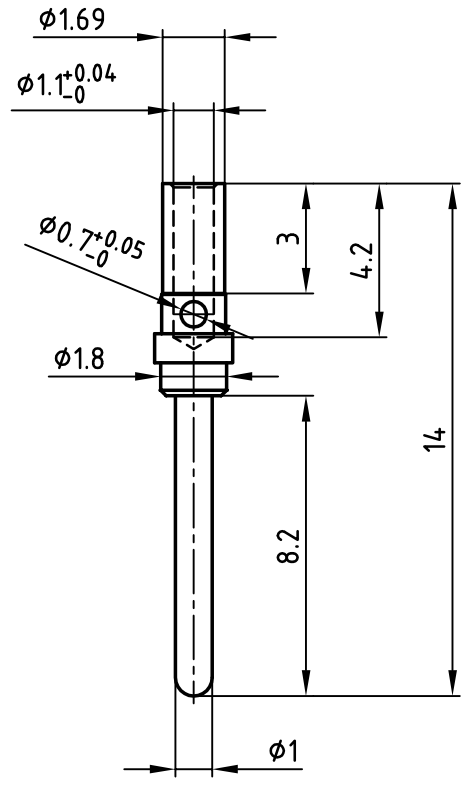

Plating	Part-NO.
min. 8µin HARD GOLD OVER min. 50µin NICKEL	<b>131A15019X</b>
min. 20µin HARD GOLD OVER min. 50µin NICKEL	<b>131B15019X</b>
min. 30µin HARD GOLD OVER min. 50µin NICKEL	<b>131C15019X</b>
min. 50µin HARD GOLD OVER min. 50µin NICKEL	<b>131J15019X</b>



**(b) STRIPPING DIMENSION**

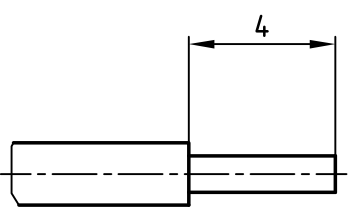

**NOTES:**

1. MATERIAL: COPPER ALLOY
2. PLATING: SEE TABLE
- (b) 3. CRIMPING: USE CRIMP TOOL 360X10329X WITH TOOL INSERT 360X20039X  
SELECTOR SETTINGS: 7 FOR AWG 20  
6 FOR AWG 22  
5 FOR AWG 24

THIS DRAWING MAY NOT BE COPIED OR REPRODUCED IN ANY WAY, AND MAY NOT BE PASSED ON TO A THIRD PARTY WITHOUT WRITTEN PERMISSION.  
 OWNERSHIP AND COPYRIGHT OF CONEC GmbH  
 DO NOT ALTER CAD DRAWING BY HAND

				tolerance				scale:	5:1
				material:		SEE NOTES			
				title:		SIGNAL CRIMP CONTACT MALE CONTACT Wire Size 20-24			
2002	date	name							
drawn	30.01.	Parei							
appd.	30.01.	E. Mickenbecker							
norm									
1 x d	Ä 3703	02.08.2010	K.H.	d-old	dwg no:		AutoCAD 2000	DIN-A	
1 x c	Ä 2197	01.04.2005	Lehmen	16K1A470A				4	
2 x b	Ä 2177	02.03.2005	Lehmen	part no:		SEE TABLE			
rev.	description	date	name					sh: 1/1	

4

3

2

1