

THIS DRAWING IS UNPUBLISHED. RELEASED FOR PUBLICATION  
 BY AMP INCORPORATED. ALL RIGHTS RESERVED.

LOC		DIST		REVISIONS			
P	LTR	DESCRIPTION	DATE	OWN	APVD		
BD	36	J	14 SEP 95	-	-		
		REDRAWN PER EC 0020-1178-94					

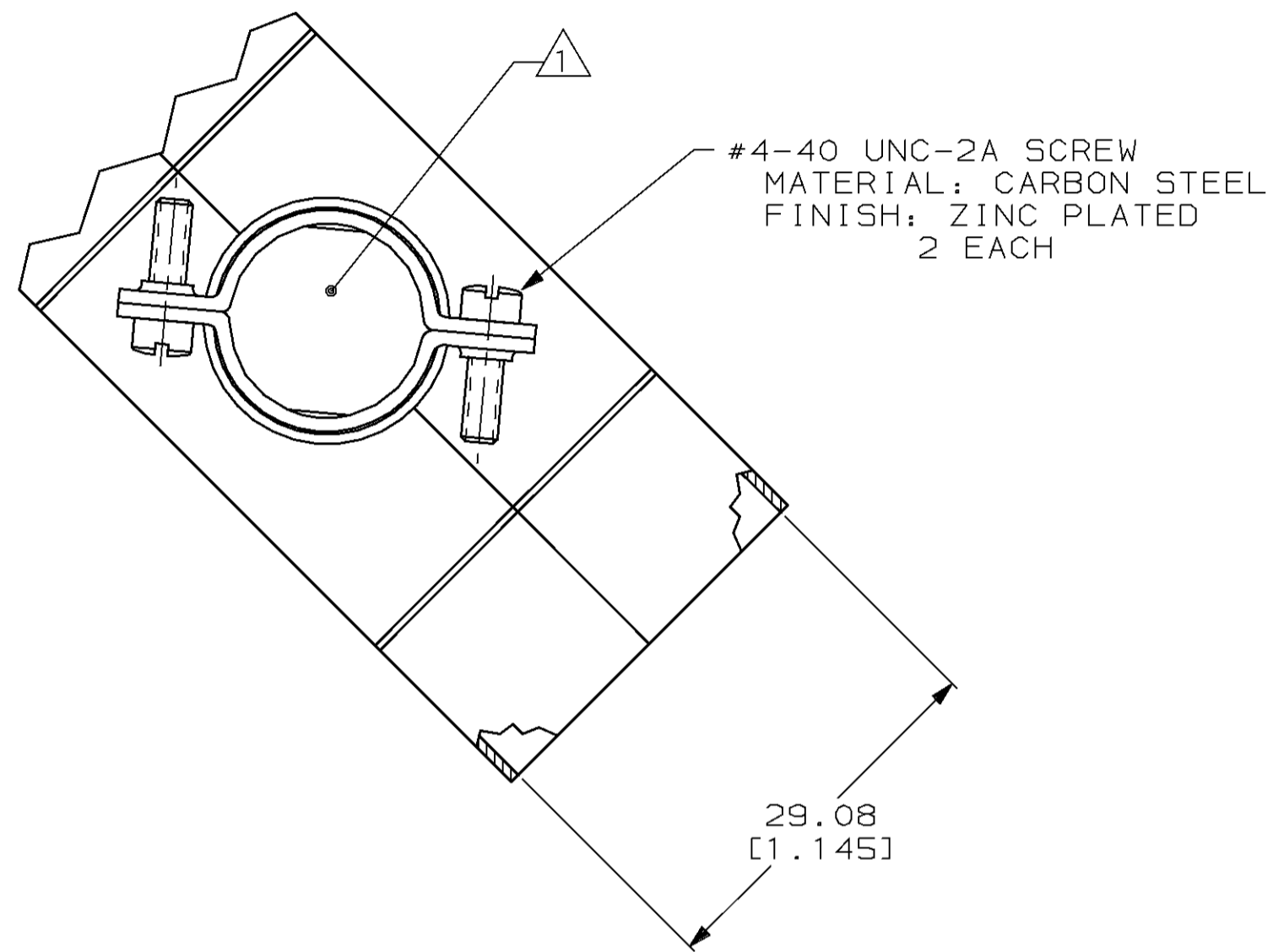

AMP, PART NUMBER AND DATE CODE MARKED IN THIS AREA

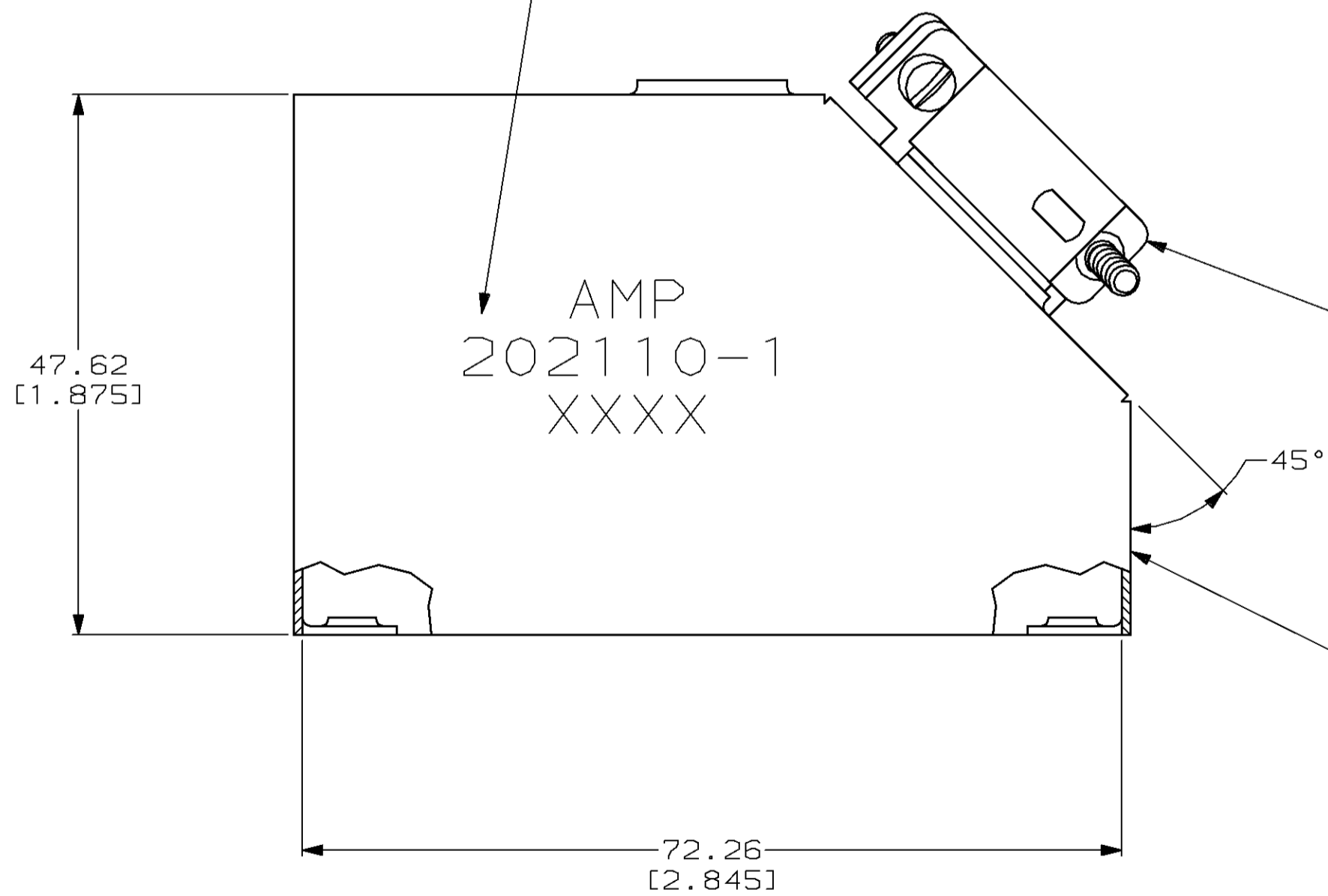

202110-1  
 PART NUMBER

△ ACCOMMODATES 15.24-17.78 [.600-.700] DIAMETER CABLE.

<small>THIS DRAWING IS A CONTROLLED DOCUMENT FOR AMP INCORPORATED. IT IS SUBJECT TO CHANGE AND THE CONTROLLING ENGINEERING ORGANIZATION SHOULD BE CONTACTED FOR THE LATEST REVISION.</small>		DWN C. DORWART 14 SEP 95 CHK R. STONE 19 SEP 95 APVD G. STEINHAUER 05 OCT 95	<b>AMP</b> AMP Incorporated Harrisburg, PA 17105-3608
DIMENSIONS: mm [INCHES]	TOLERANCES UNLESS OTHERWISE SPECIFIED: 0 PLC ±- 1 PLC ±- 2 PLC ±0.38 [.015] 3 PLC ±- 4 PLC ±- ANGLES ±1°	PRODUCT SPEC APPLICATION SPEC	<b>SHIELD KIT, UNASSEMBLED, 104 POSITION, M SERIES</b>
MATERIAL SEE CALLOUTS	FINISH SEE CALLOUTS	WEIGHT -	SIZE A2 CAGE CODE 00779 DRAWING NO. ©=202110
CUSTOMER DRAWING		SCALE 2:1	SHEET 1 OF 1 REV J