

DESCRIPTION

The AL8860QEV1, Figure 1, is a double-sided evaluation board for the AL8860Q step-down, or ‘buck’, LED driver with internal switch. The evaluation board is preset to drive 1.5A into a single LED, or multiple LEDs, the maximum number of which depends on their total forward voltage drop and the supply voltage. (The maximum drive current of the AL8860Q is 1.5A)

The operating voltage is nominally 40 volts, but it can be reduced to a minimum of 4.5 volts. The 68μH inductor used in the circuit is based on this nominal supply. The evaluation board should be connected as in Figure 1 below.

Note: The evaluation board does not have reverse supply protection.

The nominal current, 1.5A, is set with the 0R1 and 0R2 sense resistor, R1 and R2.

Terminal CTRL provides a connection point for DC or PWM dimming and shutdown.

Warning: At 40V nominal operation with 1.5A output, the LED will be hot and very bright



Figure 1: AL8860QEV1 evaluation board and connection diagram

AL8860QEV1 Connection Point Definition	
Name	Description
VIN	Positive supply voltage. 4.5 to 40V
GND	Supply Ground (0V).
CTRL	Internal voltage ref. pin (2.5V). This pin can be used to achieve dimming and for switching the output current off. Leave floating for normal operation.
LED A	LED A connects to the external LED anode
LED K	LED K connects to the external LED cathode

AL8860Q DEVICE DESCRIPTION

The AL8860Q is a continuous mode inductive driver in a MSOP-8EP package, for driving one or more series-connected LEDs efficiently from a voltage source higher than the LED voltage. The device includes the output switch and a current sense circuit, which requires an external sense resistor to set the nominal current up to 1.5A.

AL8860Q DEVICE FEATURES

- Drives one or more series-connected LEDs
- LEDs up to 1.5A
- Internal 40V switch
- Wide input voltage: 4.5V to 40V
- Inherent open circuit LED protection.
- Brightness control using DC or PWM.

DEVICE APPLICATIONS

- Automotive Interior LED Lamps
- Automotive Exterior LED Lamps

AL8860Q Device Packages, Pin and Definitions

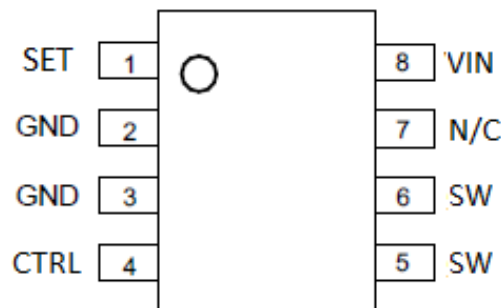

MSOP-8EP package

AL8860Q Device Pin Definition

Name	Pin No	Description
SW	5,6	Drain of NDMOS switch.
GND	2,3	Ground (0V).
CTRL	4	Internal voltage ref. pin (2.5V): <ul style="list-style-type: none"> • Leave floating for normal operation. • Connect to GND to turn off output current. • Drive with DC voltage (0.3V to 2.5V) or with PWM (up to 5V logic level) signal to adjust output current
SET	1	Connect a sense resistor, R1, from the SET pin to VIN to sense the nominal output current. Nominal $I_{out} = 0.1 / R1$
VIN	8	Input voltage: 4.5V to 40V. Decouple to ground with a 2.2µF or higher ceramic capacitor.

ORDERING INFORMATION

EVALBOARD ORDER NUMBER
AL8860QE V1

DEVICE ORDER NUMBER
AL8860QMP-13

Please note: Evaluation boards are subject to availability and qualified sales leads.

AL8860QE1 EVALUATION BOARD REFERENCE DESIGN

The AL8860QE1 is configured to the reference design in Figure 2.

The operating voltage is a nominal 40V. The nominal current is set at 1.5A with 0R1 and 0R2 sense resistors R1 and R2. The circuit operates in continuous mode at approximately 120kHz, with a 68µH inductor and one LED.

Both DC and PWM dimming can be achieved by driving the CTRL pin. For DC dimming, the CTRL pin may be driven between 0.3V and 2.5V adjusting the output current from 0% to 100% of I_{LED} . Recommended dimming range is from 5% to 100%.

Driving the CTRL pin below 0.2V will shut down the output current.

A PWM signal (low level $\leq 0.2V$ and high level > 2.5) allows the output current to be adjusted above or below the level set by the resistor connected to SET input pin. The PWM frequency can be around 100Hz to 1kHz, providing a resolution of 10 bits.

For low frequency PWM, C2 should be removed from the evaluation board, to give a more accurate duty cycle. Shorting R3 will connect the test pin CTRL to device pin CTRL, if required.

For other reference designs or further applications information, please refer to the AL8860Q datasheet.

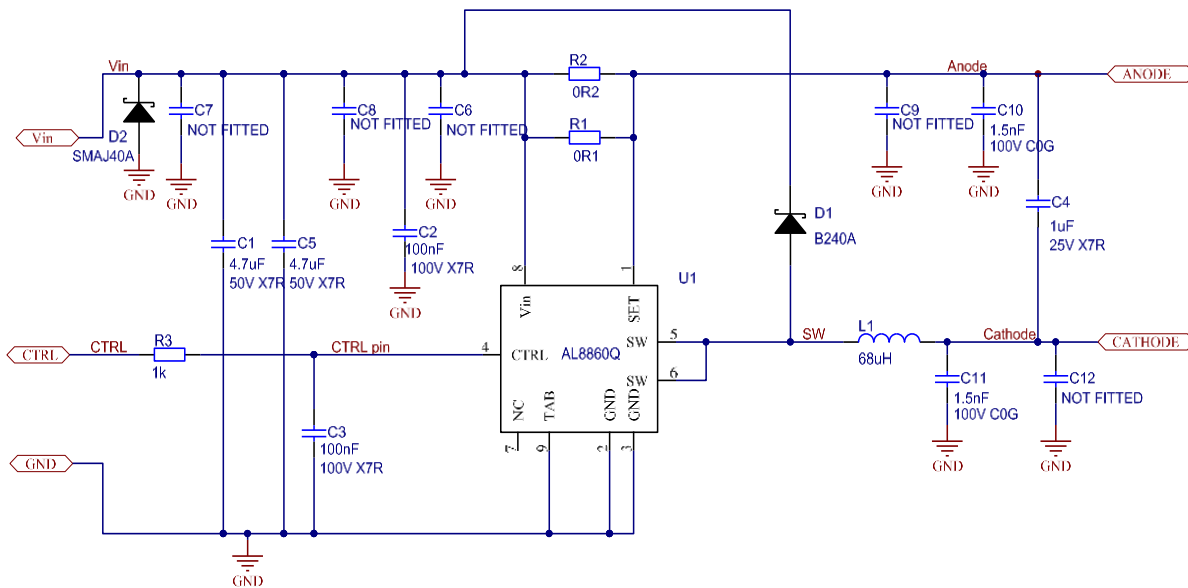

Figure 2: Schematic diagram

AL8860Q Operation

In normal operation, when a voltage is applied at +Vin, the AL8860Q internal NDMOS switch is turned on. Current starts to flow through sense resistors R1, R2, inductor L1, and the LED. The current ramps up linearly, the ramp rate being determined by the input voltage +Vin and the inductor L1. This rising current produces a voltage ramp across R1 and R2. The internal circuit of the AL8860Q senses the voltage across R1, R2 and applies a proportional voltage to the input of the internal comparator. When this voltage reaches an internally set upper threshold, the NDMOS switch is turned off. The inductor current continues to flow through R1, R2, L1, the LED and the Schottky diode D1, and back to the supply rail, but it decays, with the rate of decay determined by the forward voltage drop of the LEDs and the Schottky diode. This decaying current produces a falling voltage at R1 and R2, which is sensed by the AL8860Q. A voltage proportional to the sense voltage across R1 and R2 is applied at the input of the internal comparator. When this voltage falls to the internally set lower threshold, the NDMOS switch is turned on again. This switch-on-and-off cycle continues to provide the average LED current set by the sense resistor R1 and R2. Please refer to the datasheets for the threshold limits, AL8860Q internal circuits, electrical characteristics and parameters.

AL8860QEV1 Component list

Ref	Value	Package	Part Number	Manufacturer	Notes
U1	AL8860Q	MSOP	AL8860Q	Diodes	DC-DC converter
D1	40V, 3A	SMA	B240A	Diodes	Schottky diode
D2	40V	SMA	SMAJ40A	Diodes	TVS diode
R1	0R1	1206		Generic	1%
R2	0R2	1206		Generic	1%
R3	1k	0805		Generic	5%
C1, C5	4.7µF, 50V	1210	C1210X475K5RAC	Generic KEMET	X7R
C2, C3	100nF, 100V	0805	NMC0805X7R104K100 PF GRM21BR71H104KA01L	Generic NIC Comps MURATA	X7R
C4	1µF, 100V	1206	NMC1206X7R104K100	Generic NIC Comps	X7R
C6,C7,C8, C9, C12		0805	NOT FITTED	Generic	Fit to improve EMC performance if required
C10,C11	1.5nF,100V	0805		Generic	
L1	68µH		MSS1038-683ML NPIS24H680MTRF NPIS104F680MTRF	Coilcraft NIC Comps	

Note: The component part numbers are correct at the time of publication. Diodes Incorporated reserves the right to substitute other parts where necessary, without further notification.

AL8860QEV1 Basic operation at full voltage

1. Connect Vin and GND
Warning: The board does not feature reverse battery/supply protection.
2. Set the PSU to 40V
3. Turn on the PSU and the LED will illuminate and the current should be approximately 1.5A.
Warning: Do not stare at the LED directly.

Switching the output current off

Shorting the CTRL pin to GND will cause the LED current to go to zero.

Soft start

Adding a C2 capacitor will create a soft-start power-up sequence (1.5ms/nF). This delay will reduce the PWM dimming performance.

Changing the LED current

1. Remove R1, R2.
2. Calculate and replace sense resistor, R1, the value of which is based on the required LED current without dimming. R1 can be calculated using following equation:

$$R1 = 0.1V/I_{OUT}$$

where I_{OUT} = the LED current.

R1 = the sense resistor value in ohms.

0.1V is the nominal sense voltage with 'CTRL' open circuit or set to 2.5V.

The device calculator at the address below can be used to speed up the redesign phase:

<http://www.diodes.com/destools/calculators.html>

PERFORMANCE

The system efficiency depends on the sense resistor, supply voltage, switching frequency and the number of LEDs.

With a 30V supply and two LEDs, the switching frequency is typically 180kHz, and the efficiency level is 88%.

For further advice, please contact your local Diodes Field Applications Engineer, or one of our sales offices listed on the back page of this document.

IMPORTANT NOTICE

1. DIODES INCORPORATED AND ITS SUBSIDIARIES ("DIODES") MAKE NO WARRANTY OF ANY KIND, EXPRESS OR IMPLIED, WITH REGARDS TO ANY INFORMATION CONTAINED IN THIS DOCUMENT, INCLUDING, BUT NOT LIMITED TO, THE IMPLIED WARRANTIES OF MERCHANTABILITY, FITNESS FOR A PARTICULAR PURPOSE OR NON-INFRINGEMENT OF THIRD PARTY INTELLECTUAL PROPERTY RIGHTS (AND THEIR EQUIVALENTS UNDER THE LAWS OF ANY JURISDICTION).
2. The Information contained herein is for informational purpose only and is provided only to illustrate the operation of Diodes products described herein and application examples. Diodes does not assume any liability arising out of the application or use of this document or any product described herein. This document is intended for skilled and technically trained engineering customers and users who design with Diodes products. Diodes products may be used to facilitate safety-related applications; however, in all instances customers and users are responsible for (a) selecting the appropriate Diodes products for their applications, (b) evaluating the suitability of the Diodes products for their intended applications, (c) ensuring their applications, which incorporate Diodes products, comply the applicable legal and regulatory requirements as well as safety and functional-safety related standards, and (d) ensuring they design with appropriate safeguards (including testing, validation, quality control techniques, redundancy, malfunction prevention, and appropriate treatment for aging degradation) to minimize the risks associated with their applications.
3. Diodes assumes no liability for any application-related information, support, assistance or feedback that may be provided by Diodes from time to time. Any customer or user of this document or products described herein will assume all risks and liabilities associated with such use, and will hold Diodes and all companies whose products are represented herein or on Diodes' websites, harmless against all damages and liabilities.
4. Products described herein may be covered by one or more United States, international or foreign patents and pending patent applications. Product names and markings noted herein may also be covered by one or more United States, international or foreign trademarks and trademark applications. Diodes does not convey any license under any of its intellectual property rights or the rights of any third parties (including third parties whose products and services may be described in this document or on Diodes' website) under this document.
5. Diodes products are provided subject to Diodes' Standard Terms and Conditions of Sale (<https://www.diodes.com/about/company/terms-and-conditions/terms-and-conditions-of-sales/>) or other applicable terms. This document does not alter or expand the applicable warranties provided by Diodes. Diodes does not warrant or accept any liability whatsoever in respect of any products purchased through unauthorized sales channel.
6. Diodes products and technology may not be used for or incorporated into any products or systems whose manufacture, use or sale is prohibited under any applicable laws and regulations. Should customers or users use Diodes products in contravention of any applicable laws or regulations, or for any unintended or unauthorized application, customers and users will (a) be solely responsible for any damages, losses or penalties arising in connection therewith or as a result thereof, and (b) indemnify and hold Diodes and its representatives and agents harmless against any and all claims, damages, expenses, and attorney fees arising out of, directly or indirectly, any claim relating to any noncompliance with the applicable laws and regulations, as well as any unintended or unauthorized application.
7. While efforts have been made to ensure the information contained in this document is accurate, complete and current, it may contain technical inaccuracies, omissions and typographical errors. Diodes does not warrant that information contained in this document is error-free and Diodes is under no obligation to update or otherwise correct this information. Notwithstanding the foregoing, Diodes reserves the right to make modifications, enhancements, improvements, corrections or other changes without further notice to this document and any product described herein. This document is written in English but may be translated into multiple languages for reference. Only the English version of this document is the final and determinative format released by Diodes.
8. Any unauthorized copying, modification, distribution, transmission, display or other use of this document (or any portion hereof) is prohibited. Diodes assumes no responsibility for any losses incurred by the customers or users or any third parties arising from any such unauthorized use.

Copyright © 2021 Diodes Incorporated

www.diodes.com

Sales offices

The Americas

3050 E. Hillcrest Drive
Westlake Village,
CA 91362-3154
Tel: (+1) 805 446 4800
Fax: (+1) 805 446 4850

Europe

Kustermannpark
Balanstraße 59,
D-81541 München
Germany
Tel: (+49) 894 549 490
Fax: (+49) 894 549 4949

Taiwan

7F, No. 50,
Min Chuan Road
Hsin-Tien
Taipei, Taiwan
Tel: (+886) 289 146 000
Fax: (+886) 289 146 639

Shanghai

Rm. 606, No.1158
Changning Road
Shanghai, China
Tel: (+86) 215 241 4882
Fax: (+86) 215 241 4891

Shenzhen

Room A1103-04,
ANLIAN Plaza, #4018
Jintian Road
Futian CBD,
Shenzhen, China
Tel: (+86) 755 882 849 88
Fax: (+86) 755 882 849 99

Korea

6 Floor, Changhwa B/D,
1005-5 Yeongtong-dong,
Yeongtong-gu, Suwon-si,
Gyeonggi-do, Korea 443-813
Tel: (+82) 312 731 884
Fax: (+82) 312 731 885