

REVISIONS					
REV	ECO	DESCRIPTION	DATE	BY	APPR
A1	-	RELEASED DRAWING	Mar-24-21	Blink	Tommy

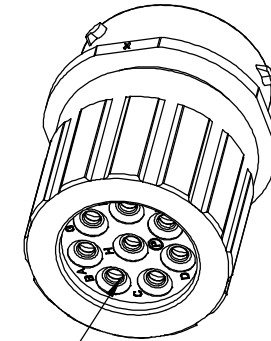
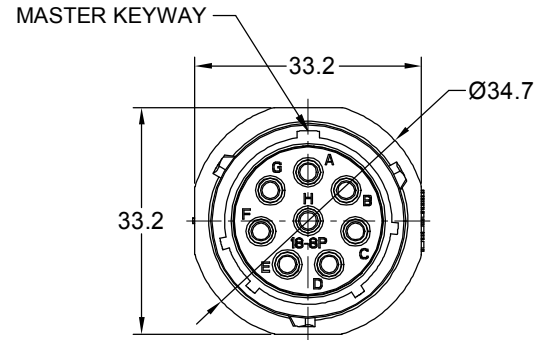
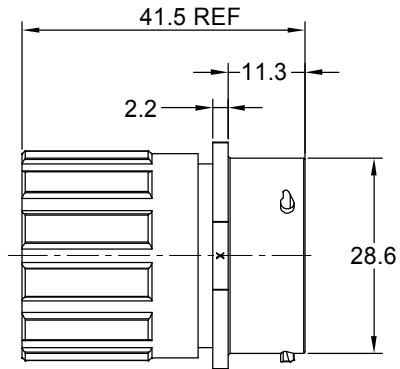

SEALING PLUGS CAN BE PURCHASED SEPARATELY

NOTES : (UNLESS OTHERWISE SPECIFIED)

- MATERIAL :
 - SHELL : THERMOPLASTIC , UL94 V-0.
 - INSERT : THERMOPLASTIC , UL94 V-0.
 - O-RING : NBR OR SILICONE RUBBER.
 - SEAL GASKET : NBR OR SILICONE RUBBER.
 - END CAP : THERMOPLASTIC , UL94 V-0.
 - PLASTIC RING: THERMOPLASTIC , UL94 V-0.
 - WIRE SEAL : SILICONE RUBBER.
- SPECIFICATIONS :
 - RATED CURRENT : 23A (MAX).
 - RATED VOLTAGE : 500V(AC/DC).
 - OPERATING TEMPERATURE : SEE TABLE.
 - DIELECTRIC WITHSTANDING VOLTAGE : LESS THAN 2 MILLIAMPS CURRENT LEAKAGE@2000 VOLTS AC.
 - INSULATION RESISTANCE : 5000 MEGOHMS MIN.
 - IP CLASS : IP67 AND IP69K IN THE MATED CONDITION, WIRE SEALS FULLY POPULATED.
 - MATING CYCLES DURABILITY : 500 CYCLES MIN.
 - RoHS COMPLIANT.
- SUITABLE CONTACTS : 2.5mm CONTACTS.
- ALL DIMENSIONS ARE FOR REFERENCE USE ONLY.

CONTACT SIZE	MIN. INSUL O.D.	MAX. INSUL O.D.	WIRE RANGE
2.5mm	Ø3.3mm	Ø4.3mm	14 - 12AWG

KEY	PART NUMBER	
		-40°C ~ 105°C
N	RTS1BS18N8PHEC	RTS1BS18N8PHEC03

QUANTITY	PART NUMBER	DESCRIPTION	ITEM
MATERIALS LIST			
UNLESS OTHERWISE SPECIFIED 1) All dimensions are in metric(mm). 2) Tolerances are as follows: 1 PL DEC ±0.30 Fractions ±1/64 2 PL DEC ±0.16 Angles ±1° 3 PL DEC ±0.08 3) Note reference =		SIGNATURES DATE DRAWN: Blink Mar-24-21 CHECKED: Flan Mar-26-21 ENGINEER: APPROVAL: Tommy Mar-30-21 CUSTOMER:	 Sine Systems - www.amphenol-sine.com 44724 Morley Drive Clinton Township, MI 48036
MATERIAL SPECIFICATIONS: PROCESS SPECIFICATIONS: NEXT ASSY:		THIS DRAWING IS SUPPLIED FOR INFORMATION ONLY. DESIGN FEATURES, SPECIFICATIONS AND PERFORMANCE DATA SHOWN HEREON ARE THE PROPERTY OF THE AMPHENOL CORPORATION. NO RIGHTS OF REPRODUCTION ARE IMPLIED. ALL DIMENSIONS ARE SUBJECT TO NORMAL MANUFACTURING VARIATIONS.	ECO-MATE AQUARIUS, RECEPTACLE, IN-LINE, SIZE 18, 8POS, PIN, END CAP. SIZE TYPE DWG NO: B C- RTS1BS18*8PHECxx A1 REVISION
SCALE: NONE		SHEET 1 OF 1	

TITLE: ECO-MATE AQUARIUS, RECEPTACLE, IN-LINE, SIZE 18, 8POS, PIN, END CAP, DWG NO.: RTS1BS18*8PHECxx REV: A1 SH: 1 OF: 1

ecomate® RM/RSSM/Aquarius™ - Contact Size 12 Options

Crimp Contacts, Machined				
Part Number		AWG	Wire Range (mm ²)	Plating
Male	Female			
N/A				

Tooling, Machined	
Part Number	Description
N/A	N/A
N/A	N/A

Plating Options, All	
Symbol	Plating
N/A	N/A

Crimp Contacts, Stamped & Formed				
Part Number		AWG	Wire Range (mm ²)	Plating
Male	Female			
SP12A1T	SS12A1T	14-12	2.5-3.5	Tin

Tooling, Stamped & Formed	
Part Number	Description
QXRT12S	Contact Extraction Tool, 2.5mm Contact
MFV-3962	Hand Tool, Stamped & Formed Contact, 2.5mm Contact

Misc Tooling, All	
Part Number	Description
CA-4012-59	Sealing Plug, Size 12

Standard Quantity Order Options	
Machined	Stamped & Formed
N/A	Reel, 1000 Pieces