

THIS COPY IS PROVIDED ON A RESTRICTED BASIS AND IS NOT TO BE USED IN ANY WAY DETRIMENTAL TO THE INTERESTS OF PANDUIT CORP.

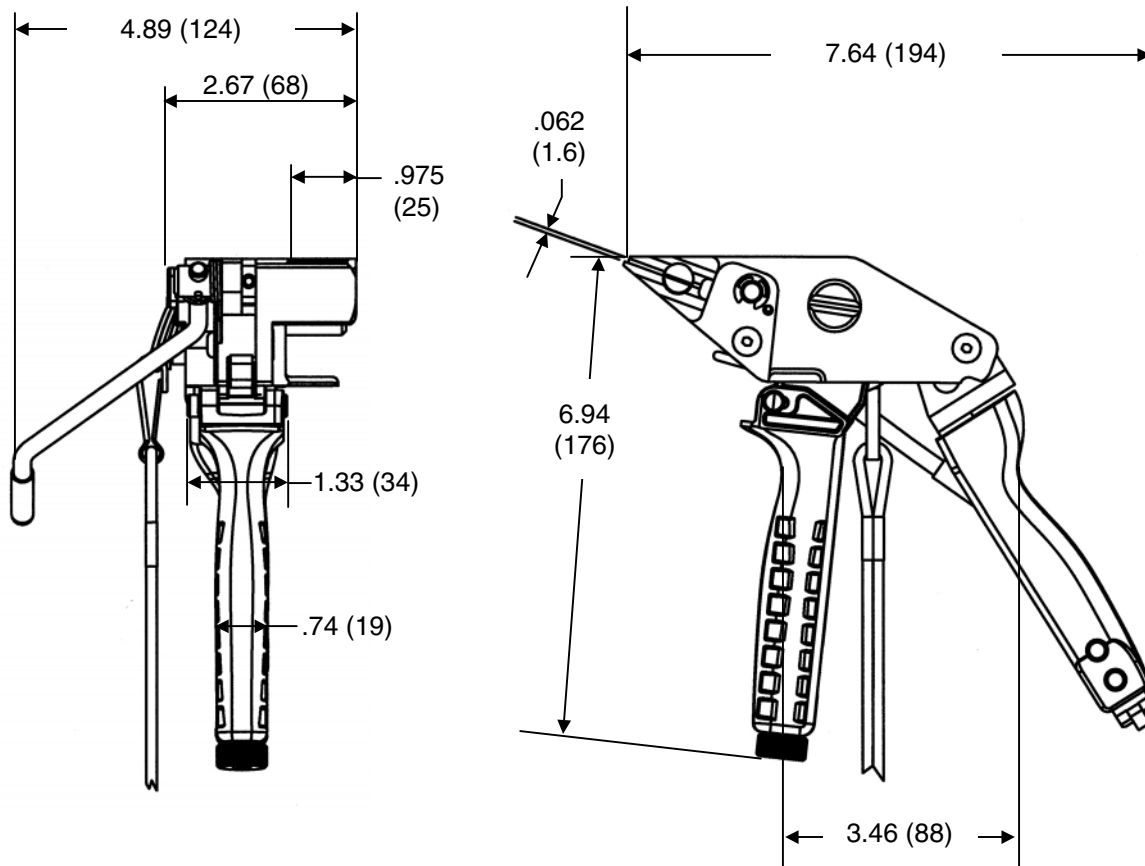

NOTES, UNLESS OTHERWISE SPECIFIED:

PANDUIT Tool Number BT1HT is used to install coated and uncoated PAN-STEEL MS Series strap and buckles in widths of 3/8" (9.5mm), 1/2" (12.7mm); and 5/8" (15.9mm).

THIS TOOLS' FEATURES INCLUDE:

- Single handle trigger for fast installation
- Cable strap side entry for immediate positioning of strap and tool
- Adjustable controlled or Installer controlled tension
- Cut-off capability with the cutter and cutter handle
- Easy removal of excess strap.
- Multi-position rear handle allows access to tight areas.
- Features to release & remove strap from tool before cutting.

CABLE TIE CROSS-SECTION CODE:

MS Series straps and buckles.

TOOL WEIGHT: 2.6 lbs. (41.6 oz.)

Dimensions shown in parenthesis are metric.

F:\wrkgrp\rvusers\ENGR DOCS-NEW\ CUSTDWG/TB24814A01_01 BT1HT.doc



CORP. TINLEY PARK, ILLINOIS

BT1HT CUSTOMER DRAWING

UNLESS OTHERWISE SPECIFIED, DIMENSIONAL TOLERANCES ARE:

(.x) ± --- (.xxx) ± ---
(.xx) ± --- ANGLES ± ---

UNLESS OTHERWISE SPECIFIED, ALL DIMENSIONS ARE GIVEN IN INCHES, THIRD ANGLE PROJECTION.

DRAWN BY:
BLR

MATL:

SCALE

DATE:
8-05-04

**SHEET
1 OF 1**

DRAWING NO.

TB24814A01

DWG
A
SIZE

REV	DATE	BY	CHK'D	DESCRIPTION	ECN	-R	CUST	SUP
01	9-15-04	BLR	ABJ	CHNG TO LOCKOUT SET SCR; MOVE LANYARD	4143		DLWE	
00	8-05-04	BLR	ABJ	RELEASED	4138	--	DLWE	