

REVISIONS			
REV	DESCRIPTION, ECN, EAR NO.	DATE	APP'D
A	PROPOSAL	OCT 08/14	L.CHAN

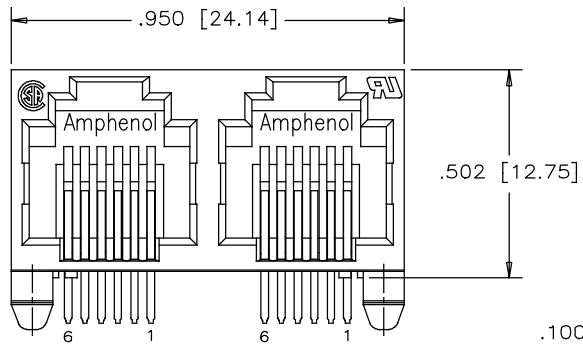

FRONT VIEW

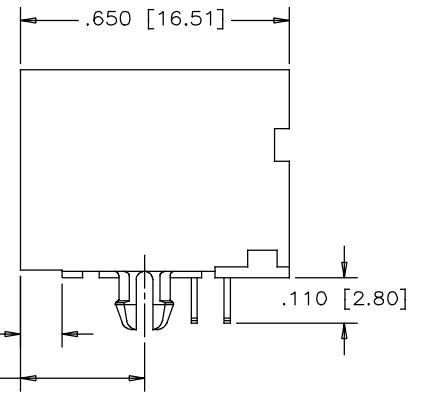

SIDE VIEW

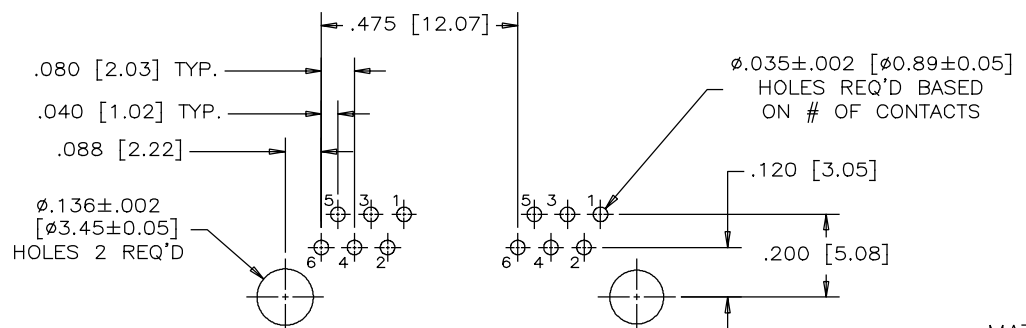

RECOMMENDED P.C.B. LAYOUT

LOCATE HOLES  
 $\text{⌀} \text{ } \text{⌀}.005 [0.13]$   
 POSITION DIMENSIONS ARE BASIC

MATERIALS:

- PLASTIC HOUSING: HIGH TEMPERATURE RESISTANT NYLON  
 UL FLAMMABILITY RATING 94V-0.  
 COLOR: BLACK
- CONTACTS: PHOSPHOR BRONZE
- CONTACT PLATING: GOLD PLATED REFER TO PART NUMBER  
 ON MATING SURFACES  
 50 MICROINCHES [1.27 MICRONS] MIN NICKEL OVERALL  
 100 MICROINCHES [2.54 MICRONS] MATTE-TIN  
 ON CONTACT TAILS.

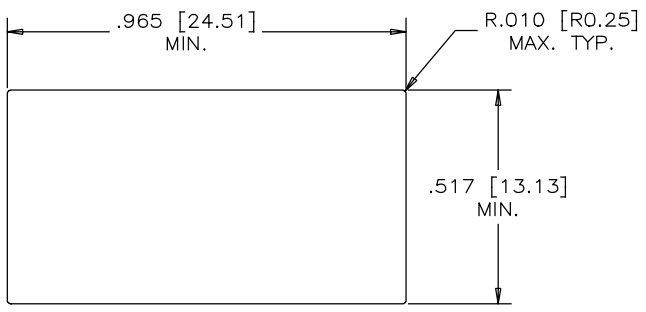

RECOMMENDED PANEL CUTOUT

PART NUMBER: RJE01-X60-02

- GOLD PLATING
- 1 = 6 μ"
  - 6 = 50 μ"
  - G = 15 μ"
  - J = 30 μ"

UNLESS SPECIFIED OTHERWISE	DRAWN <i>Frank W</i>	DATE <i>0ct 08/14</i>
PRIMARY UNITS INCH	CHECKED <i>Lawrence C</i>	DATE <i>0ct 08/14</i>
SECONDARY MILLIMETERS	M.E. APP'D	
REFERENCE IN PARENTHESES	Q.A. APP'D	
GENERAL TOLERANCES	DWG APPR.	
1 DECIMAL PLACE ±0.025	ENG. REL. NO.	
2 DECIMAL PLACES ±0.020	REF.	
3 DECIMAL PLACES ±0.015	THIRD ANGLE PROJECTION	DO NOT SCALE DRAWING
ANGULAR DEGREES ±1.0°		

Amphenol Canada Corp. www.amphenolcanada.com	
TITLE	HIGH SPEED MODULAR JACK, 2 PORTS, 6 POSITION, 6 CONTACTS, UNSHIELDED - RoHS COMPLIANT
DWG. NO.	P-RJE01-X60-02
REV	A
CODE ID NO.	03554 DWG SIZE: c SCALE: N/A SHEET 1 OF 1