

LOC	DIST	REV	DATE	BY	CHK	APPD
AD	00	A2	11MAR2011	RK	HMR	

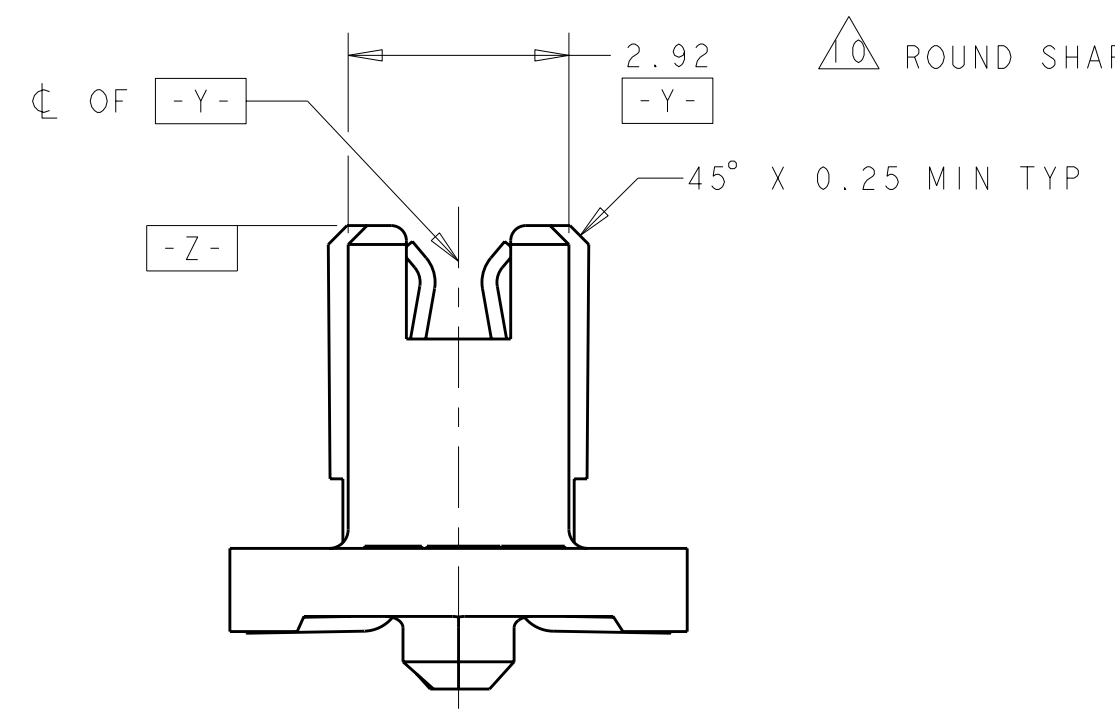

9 STYLE A POSTS

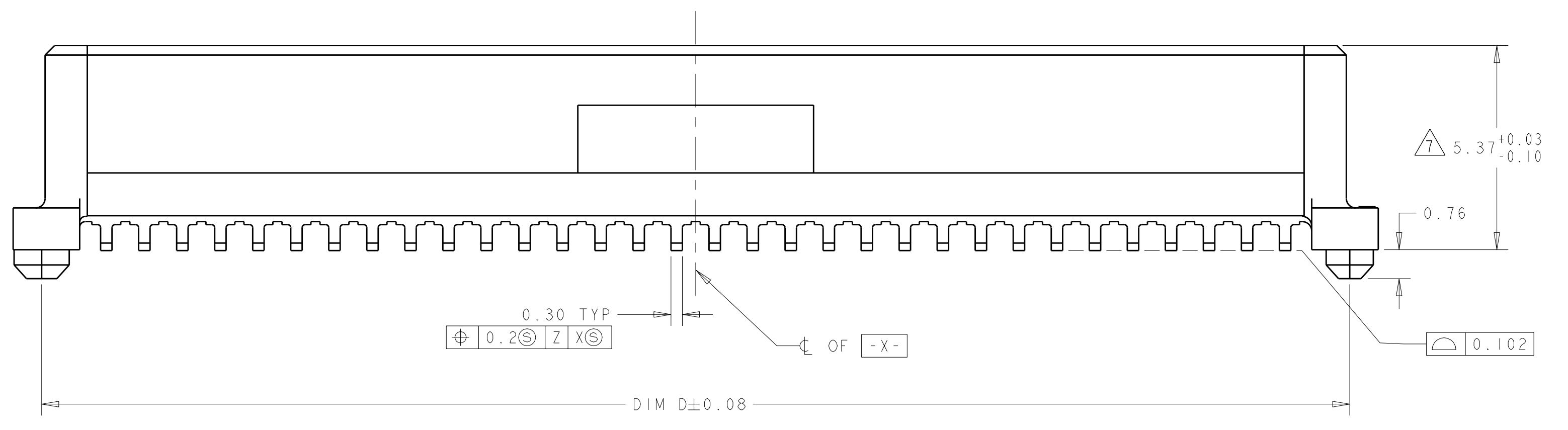
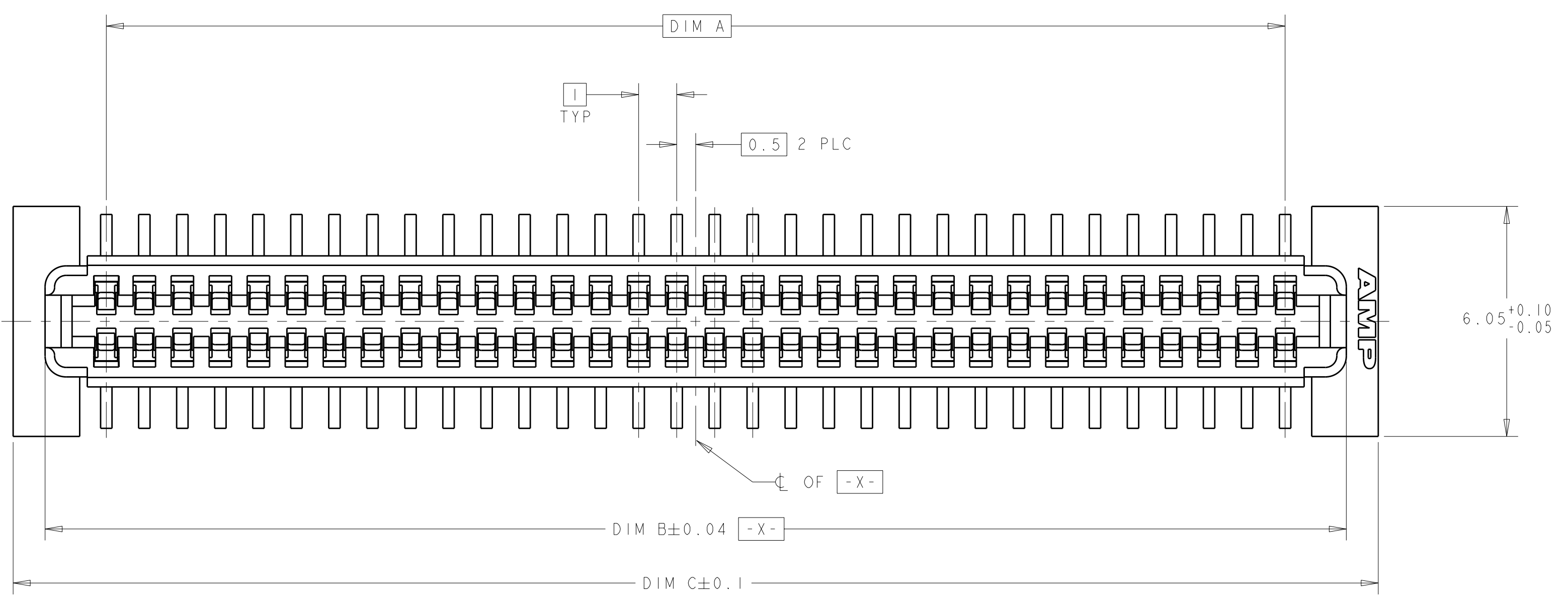
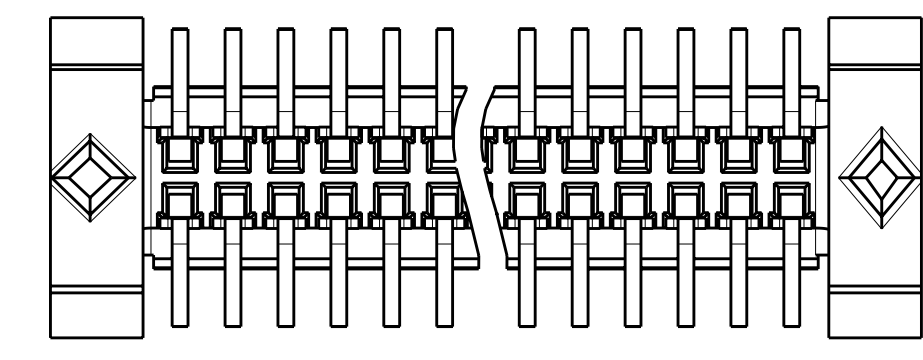

10 STYLE B POSTS

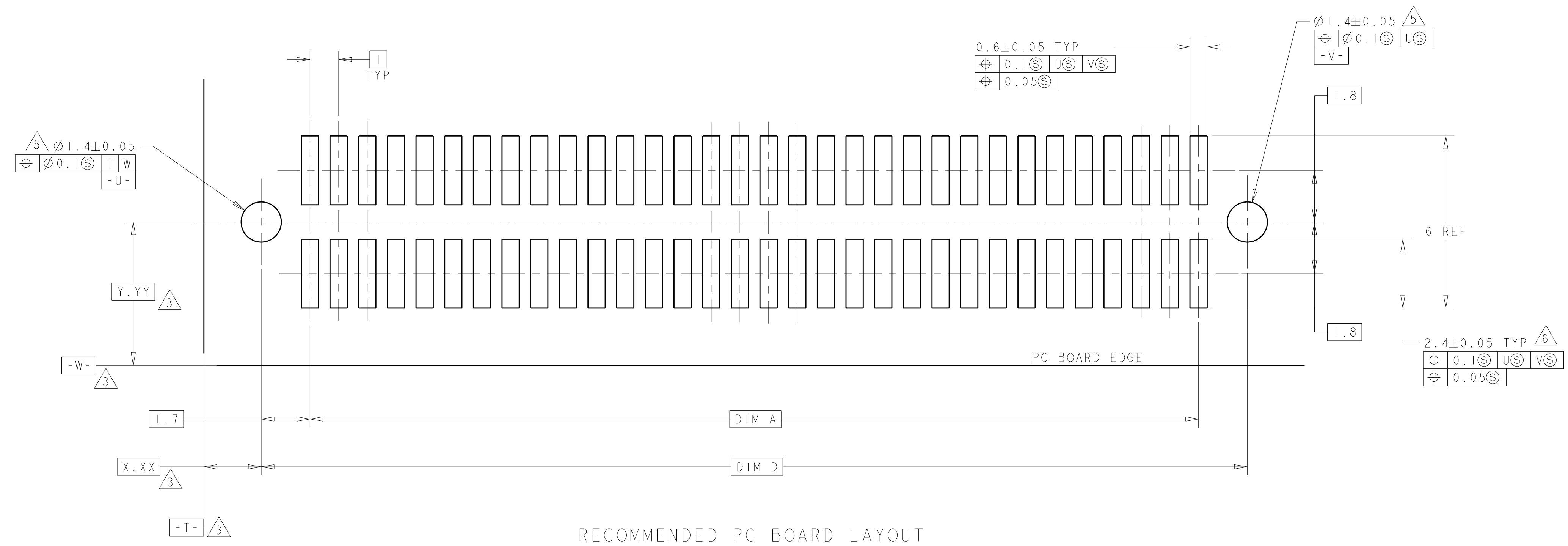
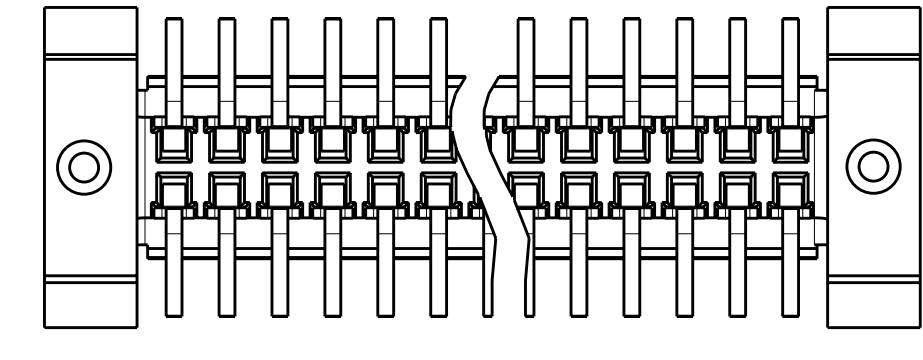

1. HOUSING MATERIAL: HIGH TEMPERATURE THERMOPLASTIC, COLOR; BLACK. CONTACT MATERIAL: PHOSPHOR BRONZE.
2. CONTACT FINISH: NICKEL UNDERPLATE ALL OVER, MATING SURFACES PLATED TO MEET PL1 PERFORMANCE REQUIREMENTS OF INDUSTRY SPECIFICATION EIA-700AAAB, SOLDER TAILS PLATED TIN.
3. DATUM LOCATIONS AND BASIC DIMENSIONS TO BE ESTABLISHED BY THE CUSTOMER. CONSULT AMP ENGINEERING WHEN PLACING MULTIPLE CONNECTORS ON A PC BOARD.
4. PACKAGED IN TAPE ON REEL PER EIA-481.
5. 1.5 MIN DIAMETER HOLE SHOULD BE USED IF USING POST STYLE "A" AND PLACING ON PCB WITH VACUUM PLACEMENT EQUIPMENT.
6. SHORTER SOLDER LANDS MAY BE USED PER EIA 700AAAB, HOWEVER 2.4 LENGTH ASSURES OPTIMUM SOLDER FILLET REGARDLESS OF MANUFACTURER OF CONNECTOR.
7. REFERRED TO AS DIM H = 5.30±0.1 IN EIA700AAAB SPECIFICATION.
8. CONTACT FINISH: 0.00381 MINIMUM MATTE TIN PER ASTM B 545 ON SOLDER AREA, 0.00127 MINIMUM GOLD PER ASTM B 488 ON MATING AREA, BOTH OVER 0.00127 MINIMUM NICKEL PER SAE-AMS-QQ-N-290 ON ENTIRE CONTACT.
9. SQUARE AND DIAMOND SHAPED POSTS
10. ROUND SHAPED POSTS

POST STYLE	FINISH	DIM D	DIM C	DIM B	DIM A	STACK HGTS	POS	PART NO
10	8	44.4	45.9	44.22	41	8, 9, 10	84	3-5120521-2
10	8	34.4	35.9	34.22	31	8, 9, 10	64	3-5120521-1
10	2	44.4	45.9	44.22	41	8, 9, 10	84	2-5120521-2
10	2	34.4	35.9	34.22	31	8, 9, 10	64	2-5120521-1
9	8	44.4	45.9	44.22	41	8, 9, 10	84	1-5120521-2
9	8	34.4	35.9	34.22	31	8, 9, 10	64	1-5120521-1
9	2	44.4	45.9	44.22	41	8, 9, 10	84	5120521-2
9	2	34.4	35.9	34.22	31	8, 9, 10	64	5120521-1

THIS DRAWING IS A CONTROLLED DOCUMENT.

DIMENSIONS: mm
 TOLERANCES UNLESS OTHERWISE SPECIFIED:
 9 PLC ±
 1 PLC ±0.03
 2 PLC ±0.03
 3 PLC ±
 4 PLC ±
 ANGLES 40°-1°
 FINISH SEE TABLE

DWN: B. CARBO
 CHK: R. WERTZ
 APPD: R. WERTZ
 PRODUCT SPEC: 502-1079
 APPLICATION SPEC: 114-25045
 WEIGHT: -
 CUSTOMER DRAWING

NAME: RECEPTACLE ASSY, 1.0mm FH (IEEE1386) CONNECTOR
 SIZE: A100779
 SCALE: 10:1
 SHEET: 1 OF 1
 REV: A2

STP
 TE Connectivity