

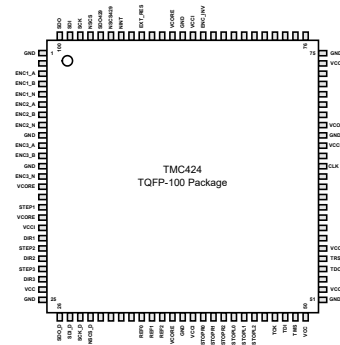

## TMC424 – Datasheet

### Serial Triple Incremental Encoder Interface

TRINAMIC Motion Control GmbH & Co. KG  
Hamburg  
GERMANY  
[WWW.TRINAMIC.COM](http://WWW.TRINAMIC.COM)



### TMC424 Main Features

The TMC424 is a triple incremental encoder input chip, which interfaces to any SPI™ compatible controller. The TMC424 can especially be used in conjunction with the TMC429 triple stepper motor controller to provide position verification or stabilization using some additional software. It integrates 24 bit counters for each encoder to provide a high position resolution without CPU interaction. Further it allows dynamic resolution adaptation to allow direct comparison of encoder counters with motors using a different micro step resolution. All encoder counters can be latched synchronously, or whenever a null channel event occurs, providing a position on strobe holding function. The TMC424 also provides a step / direction output with programmable signal shaping for the TMC429 as an optional function. A multiplexer function is also integrated for the TMC429 reference switches. All functions can also be used in conjunction.

### Applications

- Stepper Motor Position Verification
- Position Maintenance
- Incremental Encoder Interface Readout
- Step / Direction conversion for TMC429 systems

### Features

- Supports 2 and 3 channel incremental encoders with a wide range of resolutions
- Allows step / direction signal extraction from TMC429 output data stream
- Programmable pulse shaping for step / direction interface
- 24 bit integrated position resolution
- Programmable prescaler for Incremental Encoder Interface
- 4-times evaluation of encoder signals
- Fast 32 bit SPI™ interface
- Can share SPI™ interface with TMC429 and supplies separate interrupt output
- Integrates Reference Switch Multiplexers
- Package: TQ100

**Note:** SPI is Trademark of Motorola, Inc.

**Revision History**

Version	Comment	Date	Name
1.0	Derived from TMC423 rebirth datasheet V1.4	June 24, 2010	SL
1.01	Added Pin12 (GND) to Table 1	October 14, 2010	SL
1.02	Added internal Pull-Up/-Down resistors to Table 1	February 1, 2011	SL
1.03	Updated to TMC429 and TMC26x	June 30, 2011	SL
1.04	Warning hint for chamfered corner in IC package is not pin 1 reference	2015-JUN-01	BD

---

**Table of Contents**

1	Pinout.....	5
1.1	Pin Description.....	6
1.2	Recommended Operating Conditions.....	7
1.3	Electrical Characteristics.....	7
2	Block Diagram.....	8
3	Application Environment.....	9
3.1	Application Description.....	9
3.1.1	Application with TMC26x Stepper Motor Driver (SPI controlled).....	9
3.1.2	Application with Step/Direction controlled TMC26x.....	9
3.2	Application Examples.....	10
3.2.1	Application with TMC6x Stepper Motor Driver.....	10
3.2.2	Application with Step/Direction Power Stage.....	10
4	Dynamic Resolution Adaptation.....	11
5	Serial Peripheral Interface (SPI) with 32-bit Register.....	12
5.1	Description and Specification.....	12
5.2	32-bit SPI Datagram Structure.....	13
5.3	SPI 32-bit Datagram Specification.....	13
5.3.1	Overview.....	13
6	Incremental Encoder.....	14
7	Configuration Datagrams.....	15
7.1	Encoder Interface Prescaler and Null Event Configuration.....	15
7.2	Encoder Interface Hold Register Operation.....	16
7.3	Timer Logic Step Pulse Length and Delay.....	17
7.4	Control Register and Interrupt Control.....	17
7.5	N-Channel Read Back.....	17
8	SPI-Protocol for Interface with 6-bit Register.....	18
8.1	Step and Direction Pulse conversion.....	18
9	Package dimensions.....	19

## List of Figures

Figure 1: Pinout TMC424 .....	5
Figure 2: Block diagram of the TMC424 .....	8
Figure 3: Application Environment .....	9
Figure 4: Example for Application with SPI controlled TMC26x Stepper Motor Driver .....	10
Figure 5: Example for Application with Step/Direction Power Stage .....	10
Figure 6: TMC424 Application .....	11
Figure 7: Timing diagram of the Serial Interface .....	12
Figure 8: Structure 32-Bit Interface .....	13
Figure 9: Overview TMC424 Registers .....	13
Figure 10: Encoder Output and Evaluation .....	14
Figure 11: Crosstalk on Encoder Wire .....	14
Figure 12: Step Direction conversion .....	18
Figure 13: 100-Pin TQFP Top View .....	19
Figure 14: 100-Pin TQFP Side View .....	19
Figure 15: 100-Pin TQFP Side View Detail A .....	19

## List of Tables

Table 1: TMC424 Pinout .....	6
Table 2: Operating Conditions .....	7
Table 3: Operating Conditions .....	7
Table 4: Prescaler factors for different motors and encoders .....	11
Table 5: Interrupt Flags .....	13
Table 6: SPI Datagram Prescaler .....	16
Table 7: SPI Datagram Hold Register .....	16
Table 8: SPI Datagram Step-/Dir logic .....	17
Table 9: SPI Datagram Control Register .....	17
Table 10: N-Channel Read Back Register .....	17
Table 11: SPI Datagram Step / Direction Converter .....	18
Table 12: Datagram example and RAM contents for three step-direction drivers .....	18
Table 13: TQFP Dimensions .....	20

# 1 Pinout

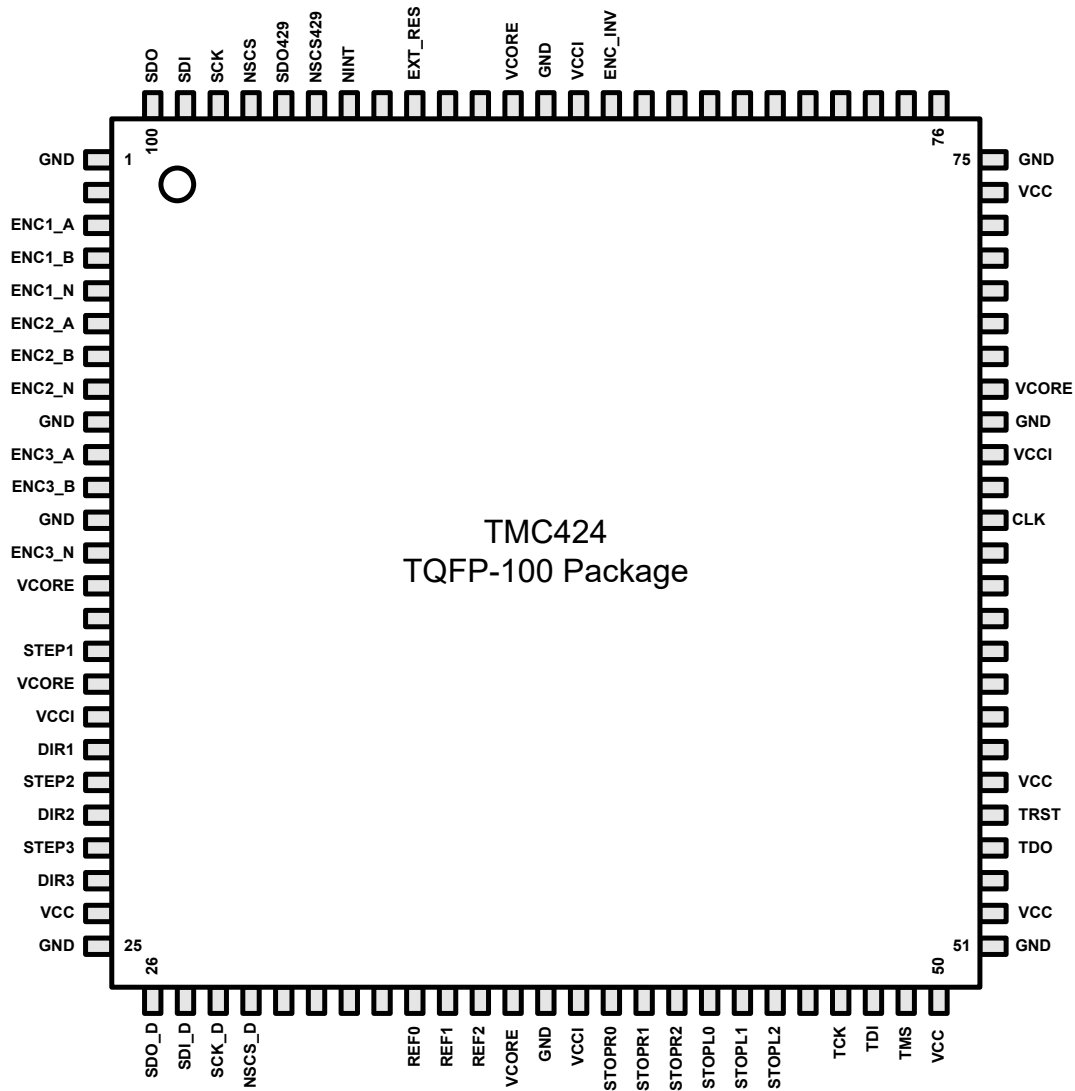

Figure 1: Pinout TMC424

## 1.1 Pin Description

Pin	Location	Dir	Pull-Up / Pull-Down	Description
GND	1, 9, 12, 25, 38, 51, 67, 75, 88			Ground
ENC1_A	3	In		Incremental Encoder Interface 1 Channel A
ENC1_B	4	In		Incremental Encoder Interface 1 Channel B
ENC1_N	5	In		Incremental Encoder Interface 1 Channel N
ENC2_A	6	In		Incremental Encoder Interface 2 Channel A
ENC2_B	7	In		Incremental Encoder Interface 2 Channel B
ENC2_N	8	In		Incremental Encoder Interface 2 Channel N
ENC3_A	10	In		Incremental Encoder Interface 3 Channel A
ENC3_B	11	In		Incremental Encoder Interface 3 Channel B
ENC3_N	13	In		Incremental Encoder Interface 3 Channel N
ENC_INV	86	In	Down	Invert all ENC <sub>x</sub> _y inputs
TDI	48			Connect to Ground
TMS	49			Connect to 3.3 Volt via Pull-Up Resistor
TRST	55			Connect to 3.3 Volt via Pull-Up Resistor
TDO	54			To be left open
TCK	47			Connect to Ground
VCCI	18, 39, 66, 87			Positive Power Supply 3.3 Volt
VCC	24, 50, 52, 56, 74			Positive Power Supply 3.3 Volt
VCORE	14, 17, 37, 68, 89			Positive Power Supply 1.5 Volt
CLK	64	In		System Clock 16MHz
EXT_RES	92	In	Up	External Reset Low Active
Step 1	16	Out		Step/Direction Interface – Step Output Motor 1
Dir 1	19	Out		Step/Direction Interface – Direction Output Motor 1
Step 2	20	Out		Step/Direction Interface – Step Output Motor 2
Dir 2	21	Out		Step/Direction Interface – Direction Output Motor 2
Step 3	22	Out		Step/Direction Interface – Step Output Motor 3
Dir 3	23	Out		Step/Direction Interface – Direction Output Motor 3
SDO_D	26	Out		Step / Direction SPI MISO
SDI_D	27	In	Up	Step / Direction SPI MOSI
SCK_D	28	In	Up	Step / Direction SPI SCK
NSCS_D	29	In	Up	Step / Direction SPI NSCS
REF0	34	Out		Reference switch output 1
REF1	35	Out		Reference switch output 2
REF2	36	Out		Reference switch output 3
STOPR0	40	In	Down	Right Stop Switch Motor 1
STOPR1	41	In	Down	Right Stop Switch Motor 2
STOPR2	42	In	Down	Right Stop Switch Motor 3
STOPL0	43	In	Down	Left Stop Switch Motor 1
STOPL1	44	In	Down	Left Stop Switch Motor 2
STOPL2	45	In	Down	Left Stop Switch Motor 3
SDO	100	Out		SPI MISO
SDI	99	In	Up	SPI MOSI
SCK	98	In	Up	SPI SCK
NSCS	97	In	Up	SPI NSCS
SDO429	96	In	Up	SPI MISO Pin of TMC429 (SDO_C)
NSCS429	95	In	Up	SPI NSCS Pin of TMC429 (nSCS_C)
NINT	94	Out		Interrupt Output (low active)

**Table 1: TMC424 Pinout**

Note: Pins which are not marked in Figure 1: Pinout TMC424 on page 5 must be left open.

## 1.2 Recommended Operating Conditions

Parameter	Value	Unit
Clock Frequency <sup>(1)</sup>	16	MHz
Temperature	0 ... +70	°C
1.5 V Power Supply	1.425 ... 1.725	V
3.3 V Power Supply	3 ... 3.6	V

**Table 2: Operating Conditions**

1 – frequencies up to 60MHz are supported. Please take care about the timing information in this datasheet, since they are based on 16MHz Clock Frequency.

## 1.3 Electrical Characteristics

Parameter	Min	Max	Unit
Supply Current 1.5V		10.5	mA
Supply Current 3.3V (Output current = 0)		1.5	mA
Input voltage level Low		0.8	V
Input voltage level High	2		V
Encoder input pulse length	2 t <sub>CLK</sub>		
Encoder count rate		f <sub>CLK</sub>	

**Table 3: Operating Conditions**

## 2 Block Diagram

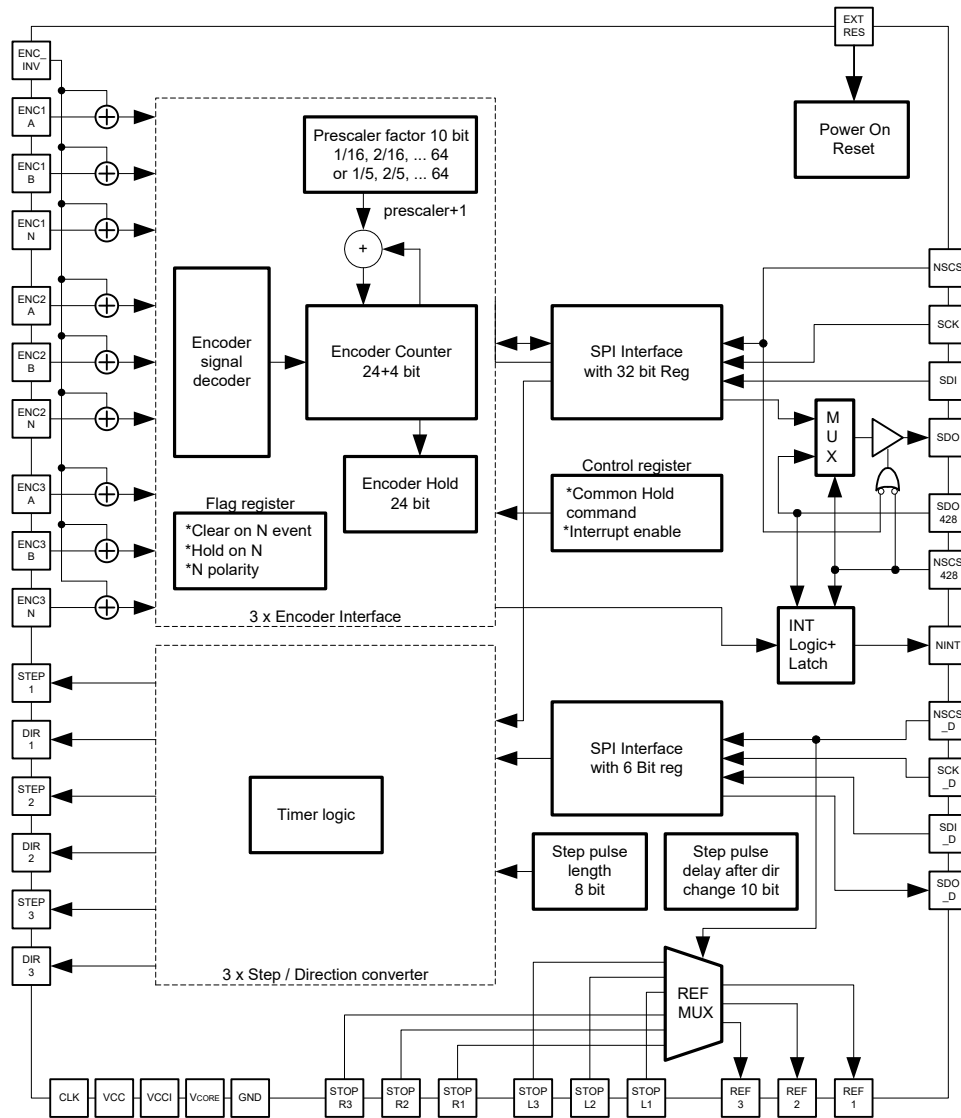

Figure 2: Block diagram of the TMC424



## 3 Application Environment

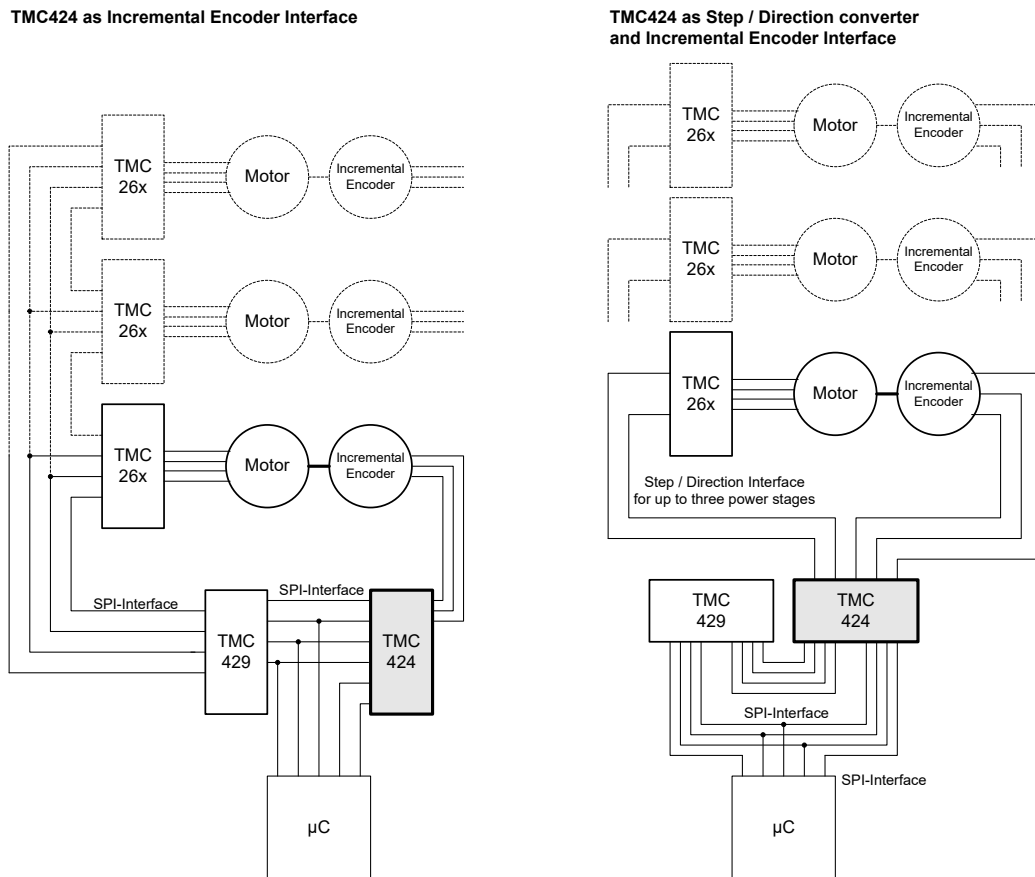

Figure 3: Application Environment

### 3.1 Application Description

#### 3.1.1 Application with TMC26x Stepper Motor Driver (SPI controlled)

A complete close-loop motion control system consists of the TMC429 three-axis motion controller, a powerful stepper motor driver from the TMC26x family and the TMC424 Encoder Interface. The system is controlled by an inexpensive microcontroller.

The main advantage of the system is that time critical communication to the TMC26x driver is performed by the TMC429. The main purpose of the inexpensive microcontroller is to parameterize the TMC429 and TMC424 and to send motion parameters like maximum speed or target position to the TMC429. Position validation is done by reading the actual position of the TMC429 and the TMC424.

The older TMC236, TMC246, TMC239 and TMC249 are also compatible with the TMC424.

#### 3.1.2 Application with Step/Direction controlled TMC26x

Another possibility to build a close loop motion control system is to use the TMC424 as encoder interface and also as a step direction converter. Thereto the TMC424 converts the SPI™ datagrams sent by the TMC429 into parameterizeable step and direction pulses. For parameterizing, both the TMC429 and TMC424 have to be connected via SPI™ interface to an inexpensive microcontroller. Since the TMC429 already has the capability to output Step/Direction signals for at least two motors (depending on the package), the conversion in the TMC424 is not needed in most cases.

### 3.2 Application Examples

#### 3.2.1 Application with TMC6x Stepper Motor Driver

This example illustrates the encoder connection and the use of reference switches with the TMC424 and additionally the SPI interface connections between TMC424, TMC429 and a microcontroller. The communication to the drivers (e.g. TMC260) is performed via SPI by the TMC429 motion control chip. On some package variants of the TMC429, the REFR pins are available. Those should be preferred to the STOPR/STOPL inputs of the TMC424's multiplexer.

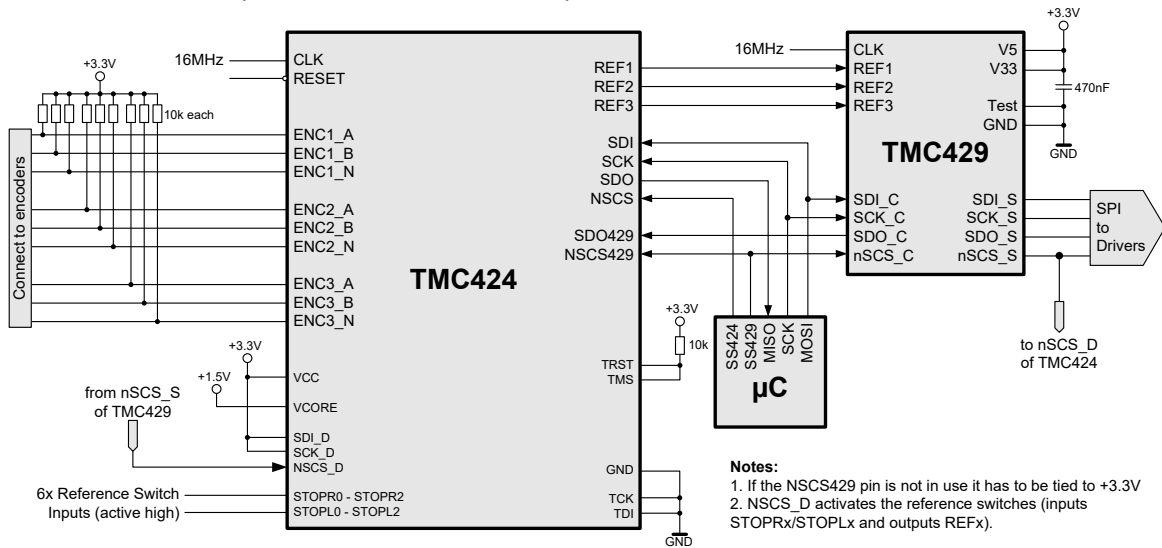

Figure 4: Example for Application with TMC26x Stepper Motor Driver

#### 3.2.2 Application with Step/Direction Power Stage

Additionally to the previous example the use of the TMC424 as step/direction converter is shown. This can be used with the TMC429 as a drop-in replacement for the TMC428. The reference switches can also be used as above.

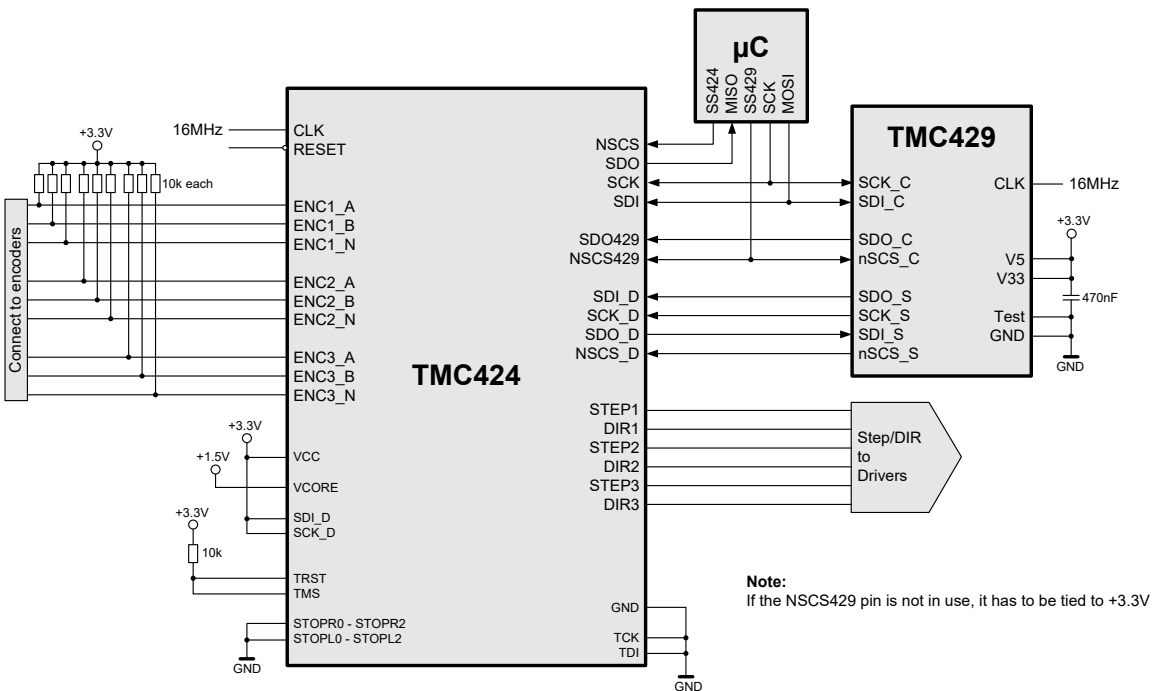
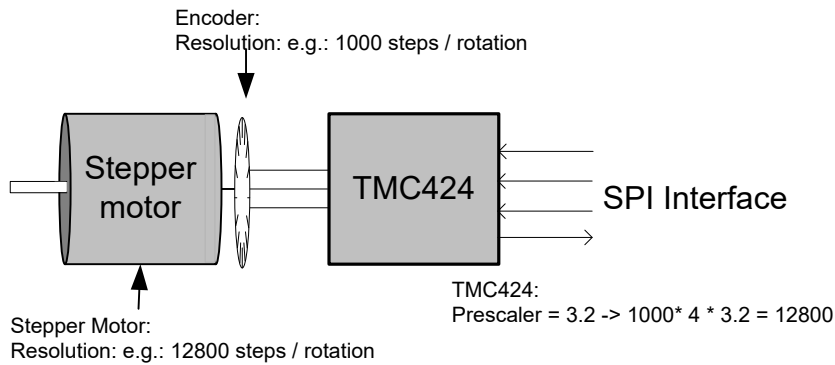

Figure 5: Example for Application with Step/Direction

## 4 Dynamic Resolution Adaptation

The dynamic resolution adaptation is needed to link stepper motors and encoders with different resolutions. The characteristics of the connected hardware must be provided to the TMC424 by sending the corresponding SPI telegram. (See 5.3.1 Overview on page 13 in this issue). The TMC424 multiplies the encoder counter by a user selectable value in the range 1..1024, and then divides it by 16. When using incremental encoders with N channel it is also possible to select between different behaviors when the N channel is triggered.



**Figure 6: TMC424 Application**

Table 4 shows a number of prescaler factors for possible combinations of micro step resolution and encoder resolution. Note: The given number of pulses have to be multiplied by four since 4-times

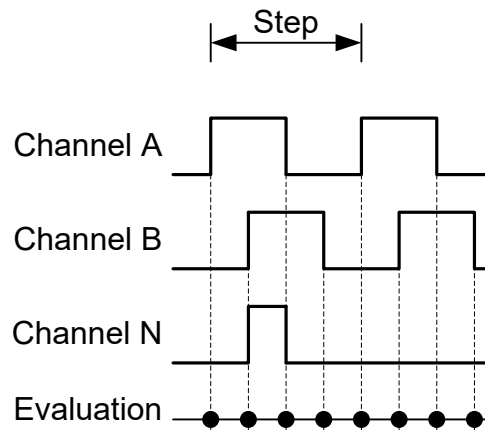

encoder signal evaluation is used. (See Figure 10: Encoder Output and Evaluation on page 14).

Microsteps	Encoder Resolution [Pulses / Rotation]									
	1024	1000	512	500	256	250	200	125	50	25
12800	3.125	3.2	6.25	6.4	12.5	12.8	16	25.6	64	----
6400	1.5625	1.6	3.125	3.2	6.25	6.4	8	12.8	32	64
3200	----	----	1.5625	1.6	3.125	3.2	4	6.4	16	32
1600	----	----	----	----	1.5625	1.6	2	3.2	8	16
800	----	----	----	----	----	----	1	1.6	4	8
400	----	----	----	----	----	----	----	----	2	4

**Table 4: Prescaler factors for different motors and encoders**

## 5 Serial Peripheral Interface (SPI) with 32-bit Register

### 5.1 Description and Specification

Four pins named nSCS, SCK, SDI and SDO form the serial peripheral interface from a microcontroller to the TMC424. The communication between the microcontroller and the TMC424 takes place via datagrams with a fixed length of 32 bit. The microcontroller always acts as master and the TMC424 as slave.

The SPI™ of the TMC424 behaves like a simple 32-bit shift register. Incoming serial data at pin SDI is shifted with the rising edge of the clock signal SCK into the 32-bit register. The content of this register is copied after 32-bits with the rising edge of the selection signal nSCS into a buffer register of 32-bit length. The SPI™ of the TMC424 sends back data read from registers immediately via the SDO signal. It processes serial data synchronously to the clock signal CLK.

Because of on-the-fly processing of the input data stream, the serial microcontroller interface of the TMC424 requires the serial data clock signal SCK to have a minimum low / high time of three clock cycles. The data signal SDI driven by the microcontroller has to be valid at the rising edge of the serial data clock input SCK. The maximum duration of the serial data clock period is unlimited.

A complete serial datagram frame has a fixed length of 32 bit. While the data transmission from the microcontroller to the TMC424 is idle, the low active serial chip select input nSCS and also the serial data clock signal SCK are set to high. The serial data input SDI of the TMC429 has to be driven by the microcontroller. Like other SPI compatible devices, the SDO signal of the TMC424 is high impedance 'Z' as long as nSCS is high.

The signal nSCS has to be high for at least three clock cycles before starting a datagram transmission. To initiate a transmission, the signal nSCS has to be set to low. Three clock cycles later the serial data clock may go low. The most significant bit (MSB) of a 32 bit wide datagram comes first and the least significant bit (LSB) is transmitted as the last one. A data transmission is finished by setting nSCS high for three or more CLK cycles after the last rising SCK slope. nSCS and SCK change in opposite order from low to high at the end of a transmission as these signals change from high to low at the beginning. The timing of the serial microcontroller interface is outlined here:

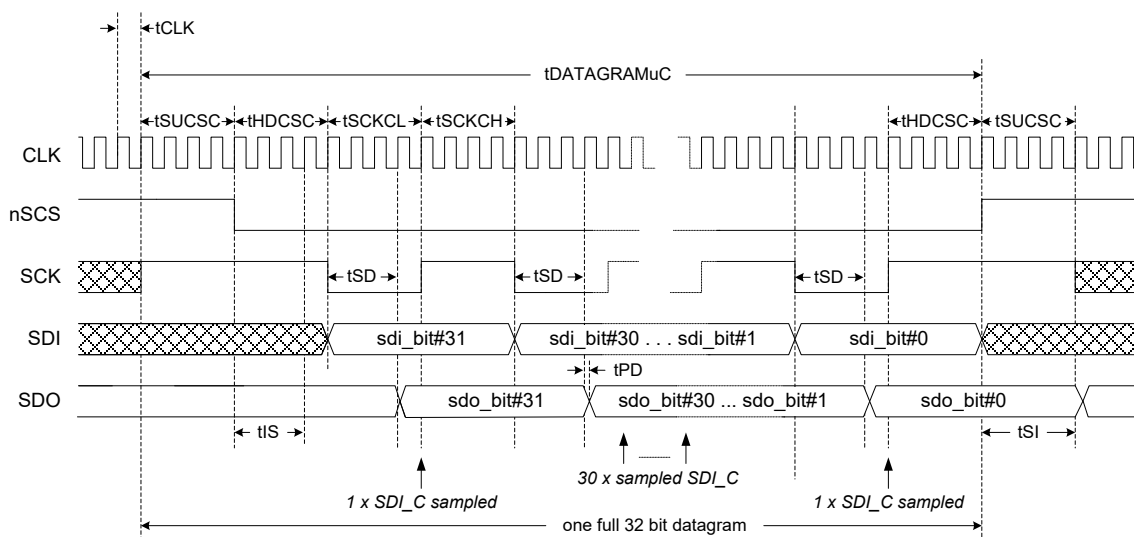

Figure 7: Timing diagram of the Serial Interface

## 5.2 32-bit SPI Datagram Structure

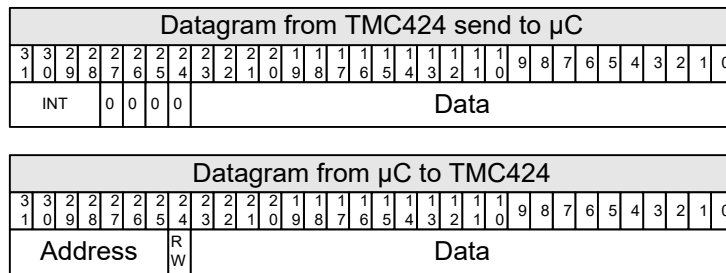

Figure 8: Structure 32-Bit Interface

Interrupt Flags [Bit]	Name	Description
31	INT_ext	external Interrupt, e.g. TMC429
30	INT_enc1	N Signal of Encoder Interface 1 detected
29	INT_enc2	N Signal of Encoder Interface 2 detected
28	INT_enc3	N Signal of Encoder Interface 3 detected

Table 5: Interrupt Flags

## 5.3 SPI 32-bit Datagram Specification

### 5.3.1 Overview

Byte #	Byte 3								Byte 2								Byte 1								Byte 0								
Bit #	31	30	29	28	27	26	25	24	23	22	21	20	19	18	17	16	15	14	13	12	11	10	9	8	7	6	5	4	3	2	1	0	
	Address								R/W																								
Control	0 0 0 0 0 0 0 1								Encoder 1 Prescaler								N Polarity N Hold N Clear N Trigger	Direction	Reserved														
	0 0 0 0 0 0 1 1								Encoder 2 Prescaler										Reserved														
	0 0 0 0 0 1 0 1								Encoder 3 Prescaler										Reserved														
	0 0 0 0 0 1 1 1								Encoder 1, 2, 3 Prescaler - set all commonly										Reserved														
Data	0 0 0 0 1 0 0 0								Encoder 1 Position Register																								
	0 0 0 0 1 0 1 0								Encoder 2 Position Register																								
	0 0 0 0 1 1 0 0								Encoder 3 Position Register																								
Step /Dir	0 0 0 0 1 1 1 1								Step Pulse Length								Step Pulse Delay								Reserved								
INT	0 0 0 1 0 0 0 1								Reg Hold	INT EN	Clear Flags									Reserved													
N-Input	0	0	0	1	0	0	1	0	0	0	0	N3	N2	N1	0	0	0	0	N3	N2	N1	0	0	0	N3	N2	N1	0	0	0	N3	N2	N1

Figure 9: Overview TMC424 Registers

## 6 Incremental Encoder

Incremental Encoders are translating the rotary motion of a shaft into a two-channel digital quadrature output. The light emitted from a LED is focused onto a reflective code wheel. As the shaft moves, the code wheel rotates, reflecting light from an alternating bright and dark pattern.

The TMC424 samples the incoming signals  $ENCx\_A$  and  $ENCx\_B$  from the incremental encoder. A internal algorithm block counts the amount of edges generated by the encoder. A prescaler value can be used to adapt the incremental encoder resolution to the stepper motor resolution.

For high resolution the TMC424 evaluates the encoder signals 4-times during each encoder step. This has to be kept in mind when choosing the prescaler value.

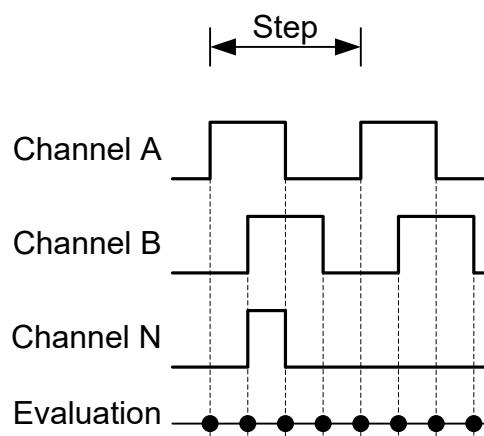

Figure 10: Encoder Output and Evaluation

Note: It is possible that the encoder signals  $ENCx\_A$ ,  $ENCx\_B$  and  $ENCx\_N$  are polluted with crosstalk noise. Crosstalk could influence the internal logic, to overcome this problem internal filters are applied to ensure correct functionality. Furthermore it saves the need for external analog filters. e.g.: Figure 11: Crosstalk on Encoder Wire shows crosstalk from channel A to channel B.

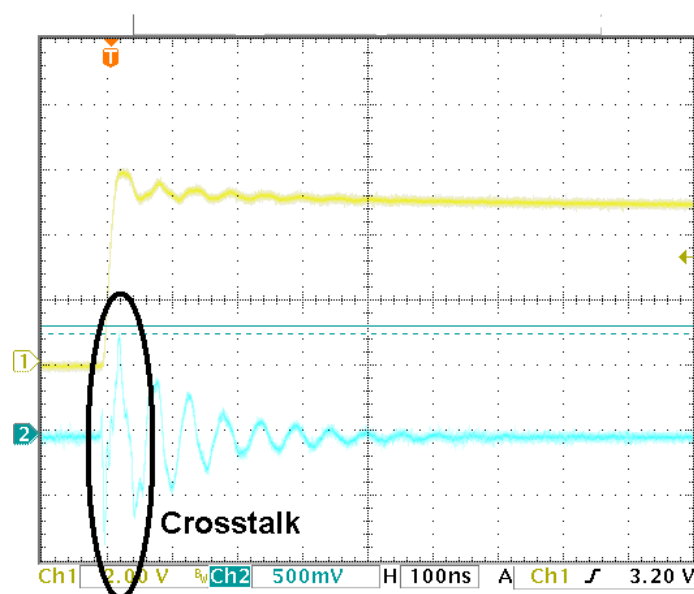

Figure 11: Crosstalk on Encoder Wire

## 7 Configuration Datagrams

### 7.1 Encoder Interface Prescaler and Null Event Configuration

The Encoder Interface Initialization datagram configures the parameterizable encoder prescaler to adapt the TMC424 for different incremental encoders. Furthermore the TMC424 behavior concerning the N channel can be selected.

Example: A 1000 steps per rotation encoder is to connect at a stepper motor with 12800 microsteps per rotation. When the next event at the high active N channel is found, the position register must set to zero. Only Encoder Interface 1 is connected.

The following datagram performs this task:

- Bits 31 down to 24 have to be set to 01<sub>HEX</sub> to select encoder interface 1
- The prescaler value has to set to  $12800 / (1000 * 4) = 3.2$ . Therefore bits 23 down to 12 must set to 831<sub>HEX</sub>.
- The N channel is set up correctly when bits 11 down to 0 are set to A0<sub>HEX</sub>.

Bit	Encoder Interface Initialization
31...28	"0000" Register Address
27...25	Interface Selection 000 = Interface 1 001 = Interface 2 010 = Interface 3 011 = Interface 1, 2 and 3
24	'1'
23...12	External Encoder Resolution and Corresponding Prescaler Factor Bits 15 ... 12: Fractional part of Factor. Unit: 1/16 (when bit 23 = 0) resp. 1/5 (bit 23 = 1) Bits 22 ... 16: Integer part of Factor Bit 23: Switches Fractional part between 1/5 resolution or 1/16 resolution  <i>Default:</i> (010) <sub>h</sub> (prescaler 1) (default value after power on)  <i>Example settings:</i> Encoder: 1024 lines (4096 steps per rotation) (032) <sub>h</sub> for 12800 micro steps per rotation (prescaler 3.125) (019) <sub>h</sub> for 6400 micro steps (prescaler 1.5625)  Encoder: 1000 lines (831) <sub>h</sub> for 12800 micro steps (prescaler 3.2) (813) <sub>h</sub> for 6400 micro steps (prescaler 1.6)  Encoder: 512 lines (064) <sub>h</sub> for 12800 micro steps (prescaler 6.25) (032) <sub>h</sub> for 6400 micro steps (prescaler 3.125) (019) <sub>h</sub> for 3200 micro steps (prescaler 1.5625)  Encoder: 500 lines (862) <sub>h</sub> for 12800 micro steps (prescaler 6.4) (831) <sub>h</sub> for 6400 micro steps (prescaler 3.2) (813) <sub>h</sub> for 3200 micro steps (prescaler 1.6)  Encoder: 256 lines (0C8) <sub>h</sub> for 12800 micro steps (prescaler 12.5) (064) <sub>h</sub> for 6400 micro steps (prescaler 6.25) (032) <sub>h</sub> for 3200 micro steps (prescaler 3.125) (019) <sub>h</sub> for 1600 micro steps (prescaler 1.5625)  Encoder: 250 lines (8C4) <sub>h</sub> for 12800 micro steps (prescaler 12.8) (862) <sub>h</sub> for 6400 micro steps (prescaler 6.4) (831) <sub>h</sub> for 3200 micro steps (prescaler 3.2) (813) <sub>h</sub> for 1600 micro steps (prescaler 1.6)  Encoder: 200 lines (100) <sub>h</sub> for 12800 micro steps (prescaler 16) (080) <sub>h</sub> for 6400 micro steps (prescaler 8)

	<p>(040)<sub>h</sub> for 3200 micro steps (prescaler 4)  (020)<sub>h</sub> for 1600 micro steps (prescaler 2)  (010)<sub>h</sub> for 800 micro steps (prescaler 1)</p> <p>Encoder: 125 lines  (993)<sub>h</sub> for 12800 micro steps (prescaler 25.6)  (8C4)<sub>h</sub> for 6400 micro steps (prescaler 12.8)  (862)<sub>h</sub> for 3200 micro steps (prescaler 6.4)  (831)<sub>h</sub> for 1600 micro steps (prescaler 3.2)  (813)<sub>h</sub> for 800 micro steps (prescaler 1.6)</p> <p>Encoder: 50 lines (200 steps per rotation)  (400)<sub>h</sub> for 12800 micro steps (prescaler 64)  (200)<sub>h</sub> for 6400 micro steps (prescaler 32)  (100)<sub>h</sub> for 3200 micro steps (prescaler 16)  (080)<sub>h</sub> for 1600 micro steps (prescaler 8)  (040)<sub>h</sub> for 800 micro steps (prescaler 4)  (020)<sub>h</sub> for 400 micro steps (prescaler 2)  (010)<sub>h</sub> for 200 steps per rotation (prescaler 1)</p>
11	<p>N Polarity for Selected Interface  0 = active low (default)  1 = active high  <i>When changing the polarity, please be aware that a single clear on N Event might be triggered, and thus should not be initiated in the same write access.</i></p>
10	<p>Hold on N for Selected Interface  0 = no hold (default)  1 = active: Encoder counter freezes during 0 channel event.</p>
9	<p>Clear on N Event for Selected Interface  0 = no clear (default)  1 = active  <i>When switched to active, then it depends on bit 8, if a clear event is issued only once, or always when the N channel becomes active.</i></p>
8	<p>N Trigger Selection  0 = only at next N signal (default)  1 = always at N signal  <i>The clear event last until the N signal goes inactive again. If earlier termination is desired, i.e. to preset the encoder counter to a different value, disable "Clear on N" prior to changing the position register.</i></p>
7	<p>add or sub register for each step (CW = looking onto the axis)  0= add for CW, sub for CCW (default)  1= add for CCW, sub for CW</p>
6...0	Reserved

Table 6: SPI Datagram Prescaler

## 7.2 Encoder Interface Hold Register Operation

To read the actual contents of the position register or to preset the position register the following command is to be used:

Bit	Encoder Interface Control (Read/Preload Encoder Hold Register)
31...28	"0000" Register Address
27...25	Select Encoder Hold Register 100 = Hold register in encoder interface 1 101 = Hold register in encoder interface 2 110 = Hold register in encoder interface 3
24	Read or Preload Selection 0 = Read encoder hold register 1 = Preload encoder hold register
23...0	Encoder Hold Register Data

Table 7: SPI Datagram Hold Register



### 7.3 Timer Logic Step Pulse Length and Delay

To parameterize the step length and delay the next datagram is to be used:

Bit	Write Step Pulse Length / Delay
31...25	“0000111” Register Address
24	‘1’
23...16	Step Pulse Length (default value = 48 <sub>(10)</sub> after PON)
15...6	Step Pulse Delay after Direction Change (default value = 160 <sub>(10)</sub> after PON)
5...0	Reserved

Table 8: SPI Datagram Step-/Dir logic

### 7.4 Control Register and Interrupt Control

This datagram configures the interrupt control of the TMC424. When enabled, the N channel pulse of all encoders is fed to the NINT pin.

Bit	Control Register
31...25	“0001000” Register Address
24	‘1’
23	Set Common Hold for Encoder Hold Registers 0 = no hold (default) 1 = freeze encoder hold registers
22	Encoder Interrupt Enable, if Null signal 0 = interrupt disable (default) 1 = interrupt enable
21	Clear Interrupt Flags 0 = no clear (default) 1 = clear flags
20...0	Reserved

Table 9: SPI Datagram Control Register

### 7.5 N-Channel Read Back

This datagram returns the state of the three N-Channel inputs ENC<sub>x</sub>\_N after the possible inverting controlled by ENC\_INV. The three inputs are sampled after transmission of the R/W bit. The three bits are repeated in the datagram for compatibility reasons as if the N-signals were connected to the SW\_ROW\_PIN(0..2) inputs of a TMC423.

Bit	Channel
31...25	“0001001” Register Address
24	‘0’
23...21, 17...15, 11...9, 5...3	“000”
20, 14, 8, 2	ENC3_N when ENC_INV = 0, not ENC3_N when ENC_INV = 1
19, 13, 7, 1	ENC2_N when ENC_INV = 0, not ENC2_N when ENC_INV = 1
18, 12, 6, 0	ENC1_N when ENC_INV = 0, not ENC1_N when ENC_INV = 1

Table 10: N-Channel Read Back Register

## 8 SPI-Protocol for Interface with 6-bit Register

The 6-bit SPI Interface is used to receive step / direction information from the TMC429. The TMC424 processes the data and issues the corresponding step / direction signals via the step / direction pins. Bit0 (Pulse 1) have to be sent first to the TMC424.

Bit	Step / Direction Converter
0	Pulse 1
1	Direction 1
2	Pulse 2
3	Direction 2
4	Pulse 3
5	Direction 3

**Table 11: SPI Datagram Step / Direction Converter**

The order of the control signals serially sent from the TMC429 has to be defined. This can be done by writing so called primary signal codes into the stepper motor driver datagram configuration area of the on-chip configuration RAM of the TMC429. This signals codes are \$13 (step first) and \$12 (direction). To switch to the next motor the next motor bit (NxM) has to be set.

Position within datagram	Driver/motor	NxM bit	TMC429 signal code	RAM data	TMC429 mnemonic of primary signal
0	1	0	\$13	\$13	Step
1		1	\$12	\$32	Direction
2	2	0	\$13	\$13	Step
3		1	\$12	\$32	Direction
4	3	0	\$13	\$13	Step
5		1	\$12	\$32	Direction

**Table 12: Datagram example and RAM contents for three step-direction drivers**

### 8.1 Step and Direction Pulse conversion

Step pulses can be modified in their pulse width and delayed after an direction change was done. The corresponding datagram (See 7.3) on page 17) is used to parameterize the Step / Dir interface.

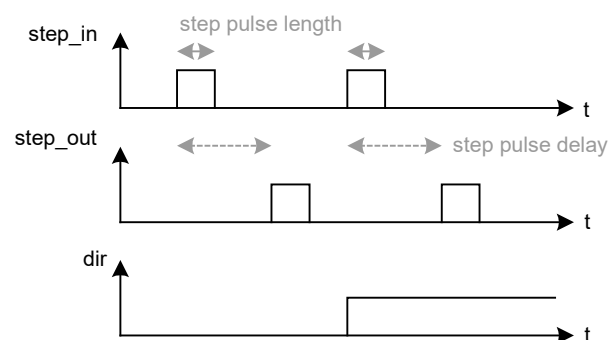

**Figure 12: Step Direction conversion**

## 9 Package dimensions

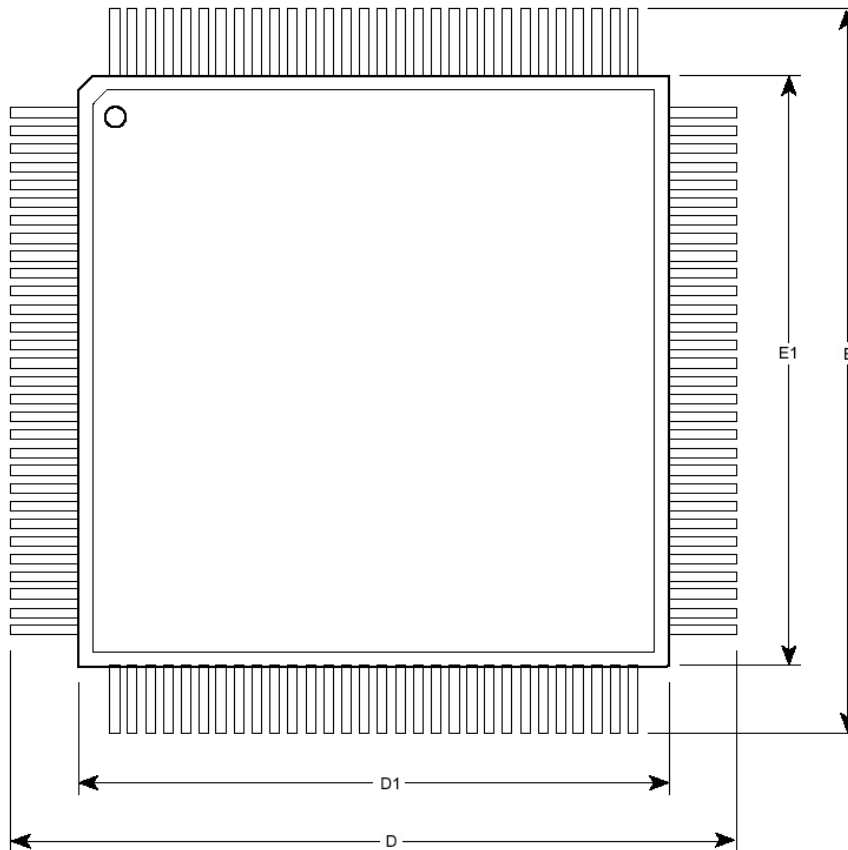

Figure 13: 100-Pin TQFP Top View

**Attention: Pin 1 marking is by dot only. The position of the chamfered corner may vary!**

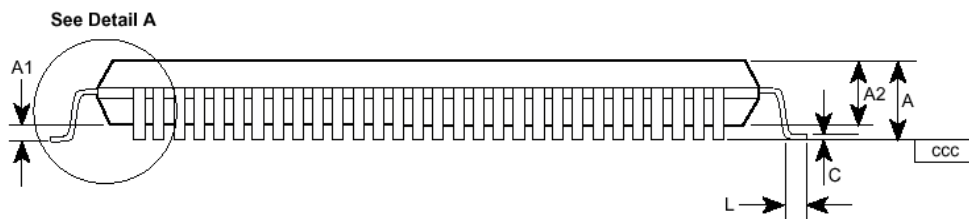

Figure 14: 100-Pin TQFP Side View

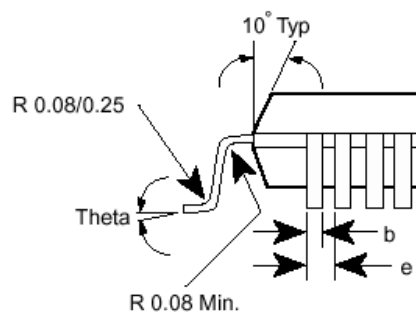

Figure 15: 100-Pin TQFP Side View Detail A

JEDEC Equivalent	TQFP100 MS-026 VAR BED		
Dimension	Min	Nom	Max
A			1.60
A1	0.05		0.15
A2	1.35	1.40	1.45
b	0.17	0.22	0.27
c	0.09		0.20
D/E		16.00 BSC	
D1/E1		14.00 BSC	
e	0.50 BSC		
L	0.45	0.60	0.75
ccc	0.08		
Theta	0	3.50 deg	7 deg

Table 13: TQFP Dimensions

**Notes :**

- all dimensions are in millimeters
- BSC Basic Spacing between Centers

## Life support policy

TRINAMIC Motion Control GmbH & Co. KG does not authorize or warrant any of its products for use in life support systems, without the specific written consent of TRINAMIC Motion Control GmbH & Co. KG. Life support systems are equipment intended to support or sustain life, and whose failure to perform, when properly used in accordance with instructions provided, can be reasonably expected to result in personal injury or death.

© 2011 TRINAMIC Motion Control GmbH & Co. KG

Information given in this data sheet is believed to be accurate and reliable. However no responsibility is assumed for the consequences of its use nor for any infringement of patents or other rights of third parties, which may result from its use.

Specifications subject to change without notice.