

REVISIONS				
P.	LTN	DESCRIPTION	DATE	APP'D
A		RELEASED PER ECO-14-015973	22OCT2014	DLD MDB
A1		REVISED PER ECO-15-010653	21JUL2015	DLD MDB
A2		REVISED PER ECO-15-011290	05AUG2015	MK MB
A3		REVISED PER ECO-17-011134	12JUL2017	VU MDB

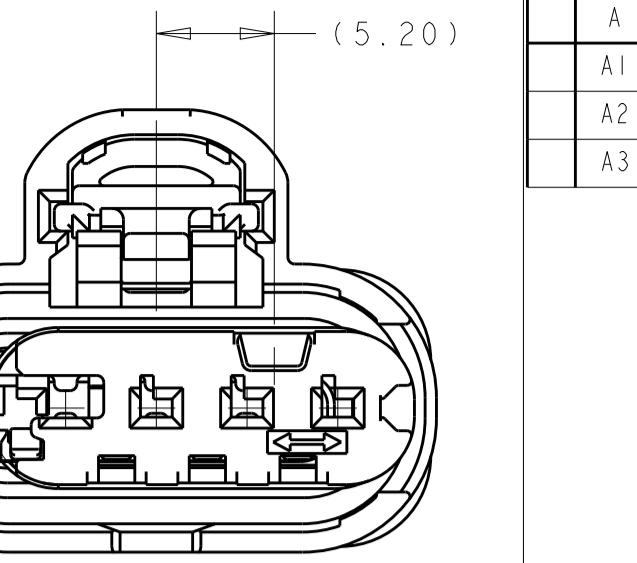
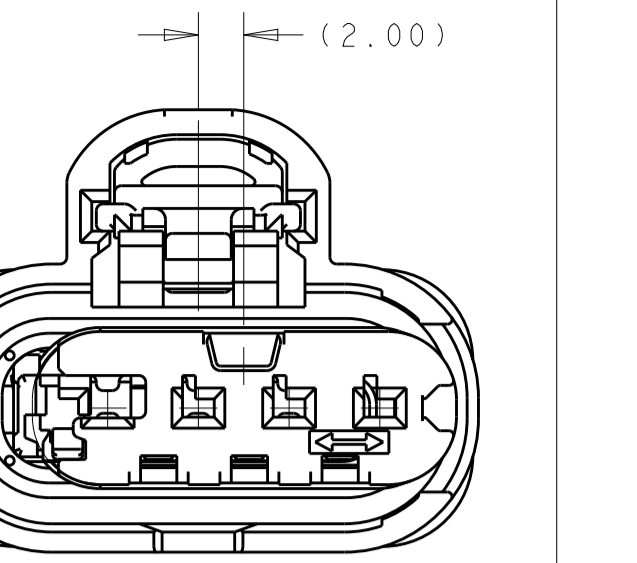
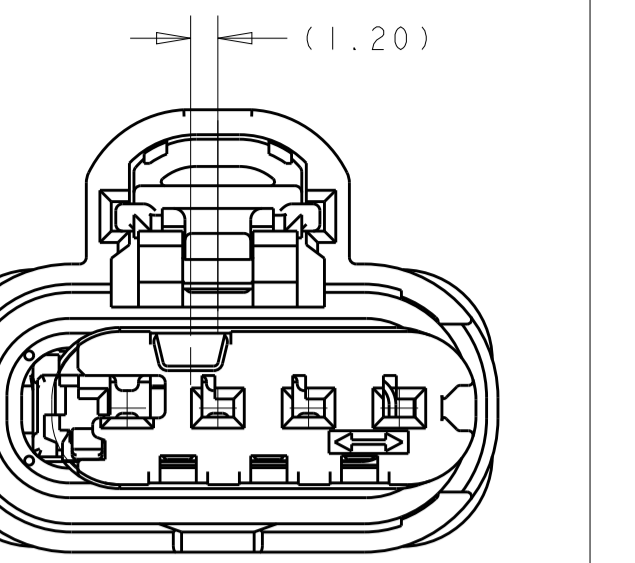
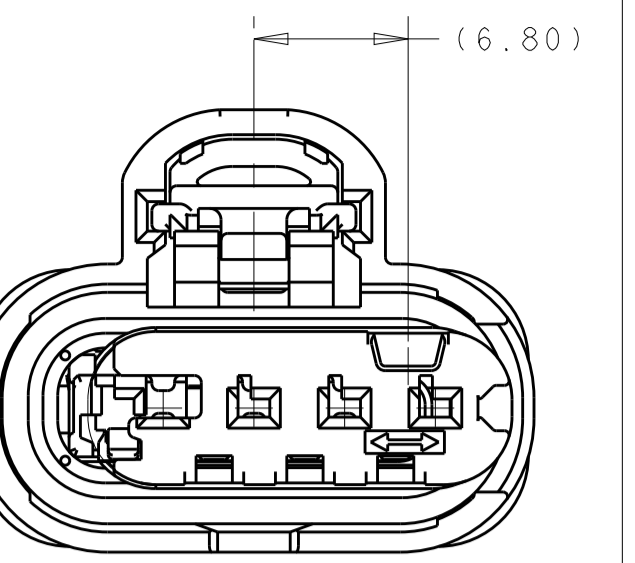
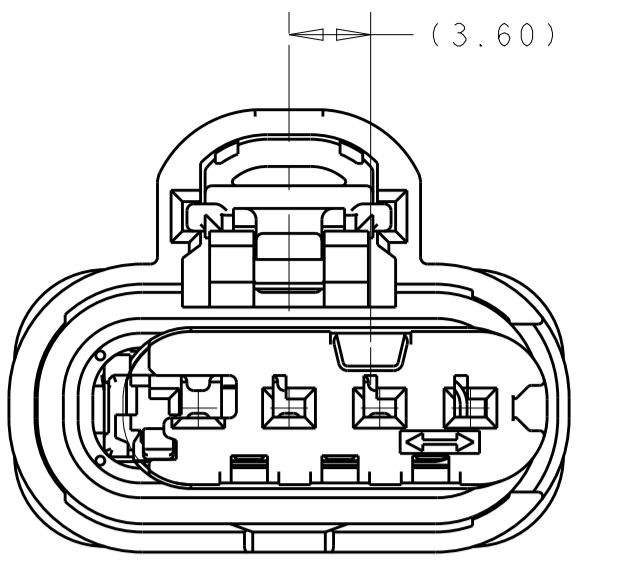
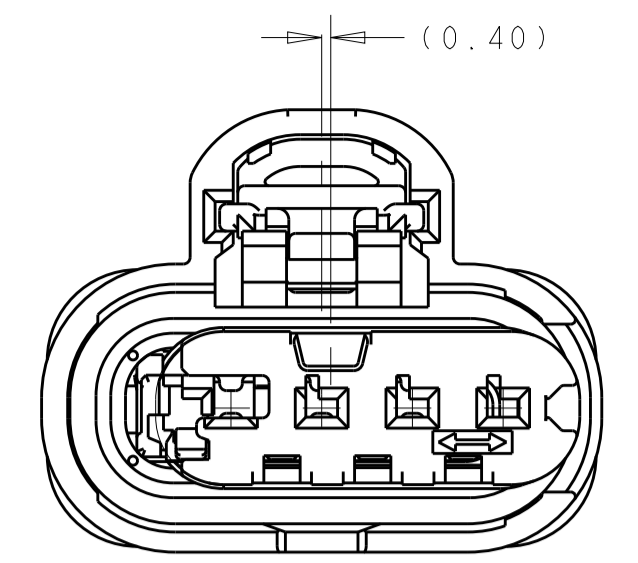
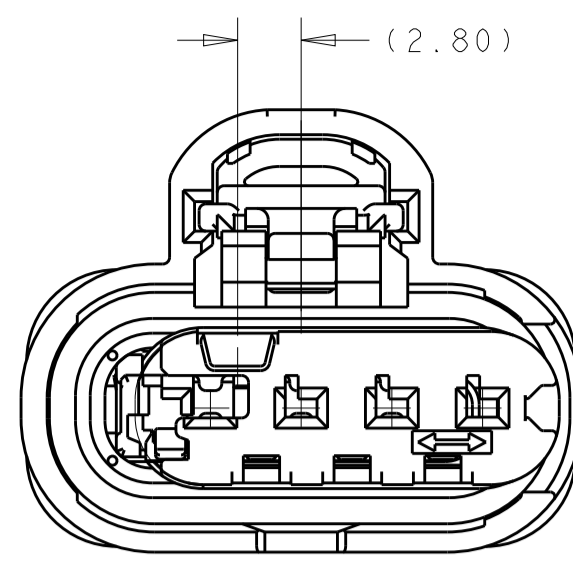

KEY CODE A SCALE 3:1

KEY CODE B SCALE 3:1

KEY CODE C SCALE 3:1

KEY CODE D SCALE 3:1

KEY CODE E SCALE 3:1

KEY CODE F SCALE 3:1

KEY CODE G SCALE 3:1

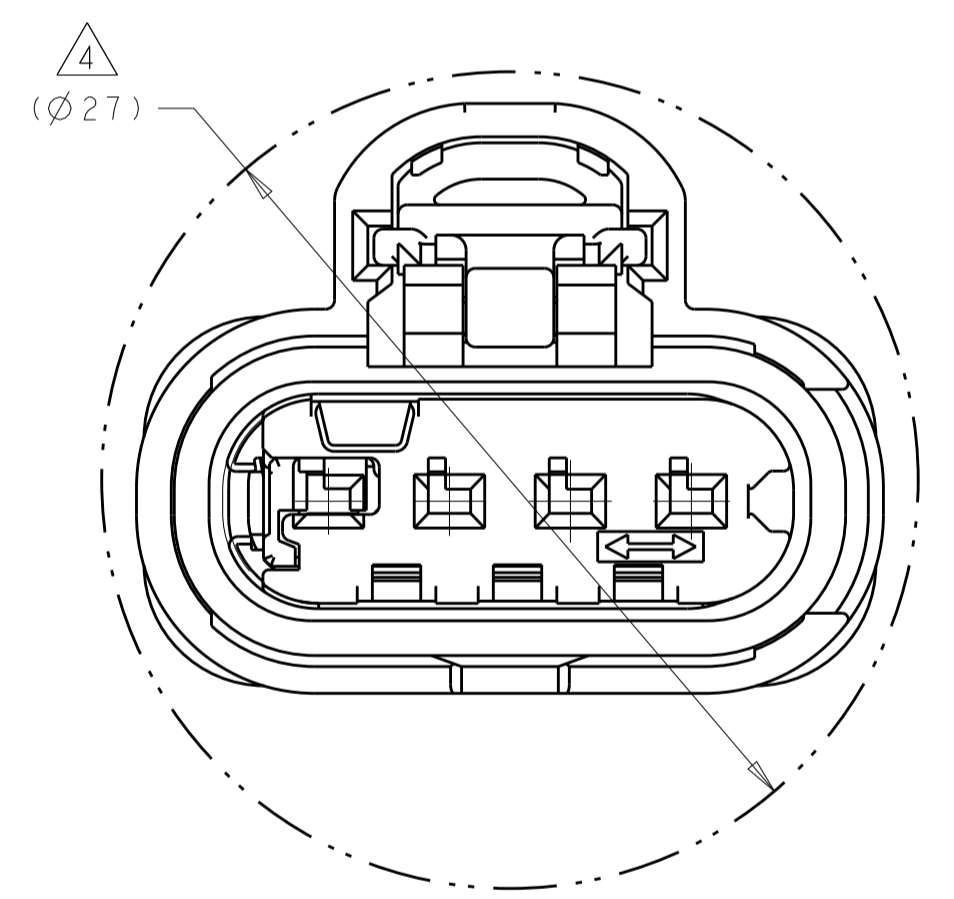
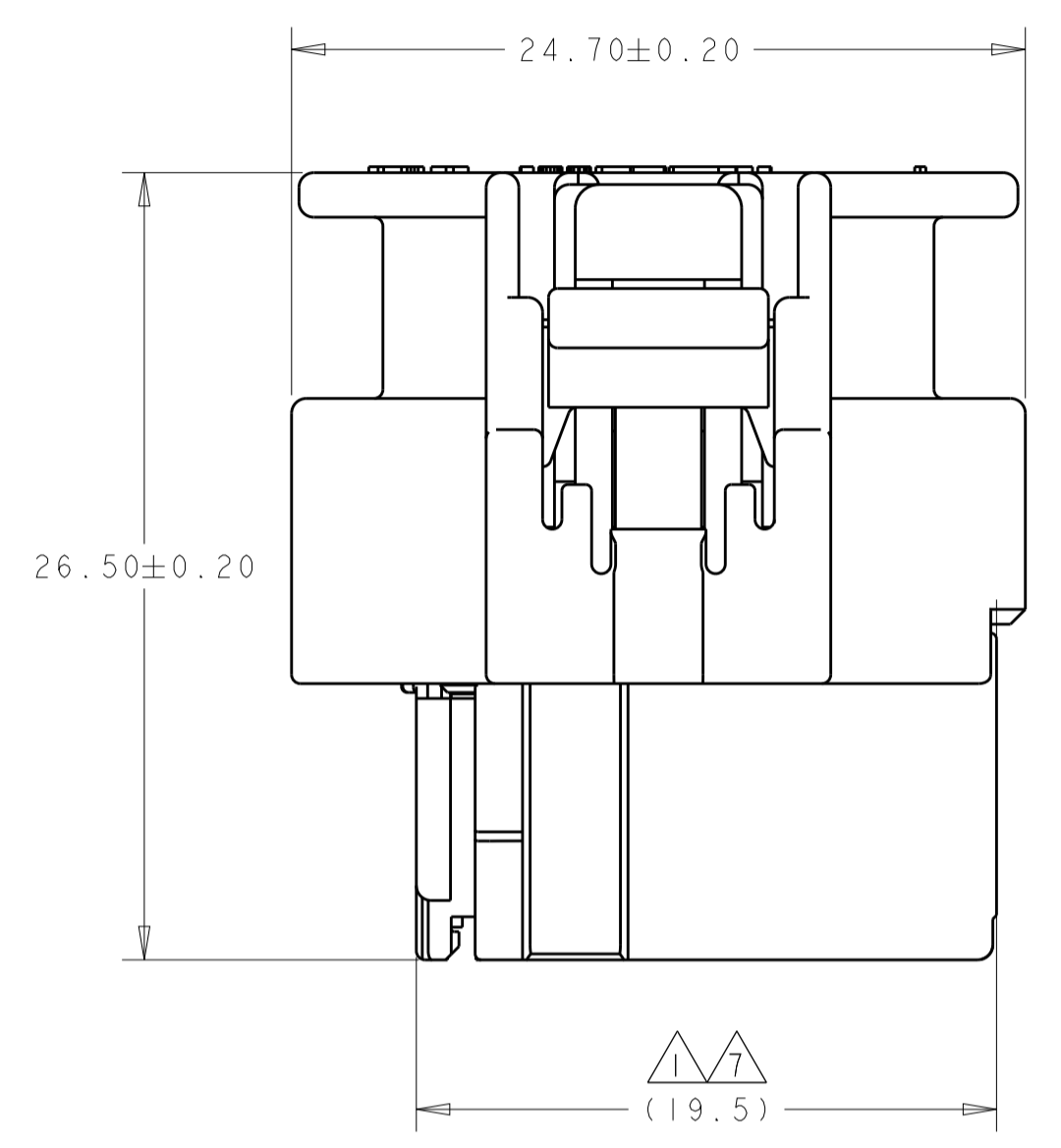

ISL SHOWN IN FINAL (LOCKED) POSITION - REF ONLY SCALE 4:1

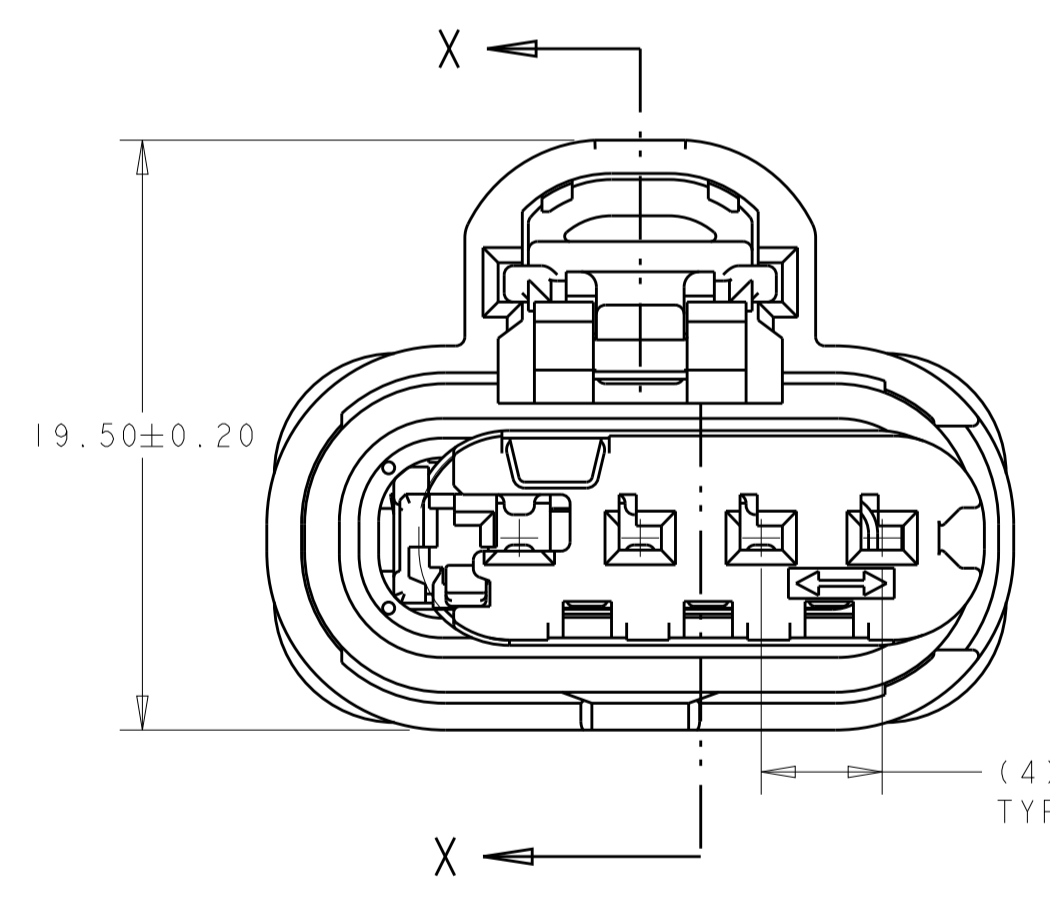

ISL SHOWN IN PRE-LATCHED (AS-SHIPED) POSITION

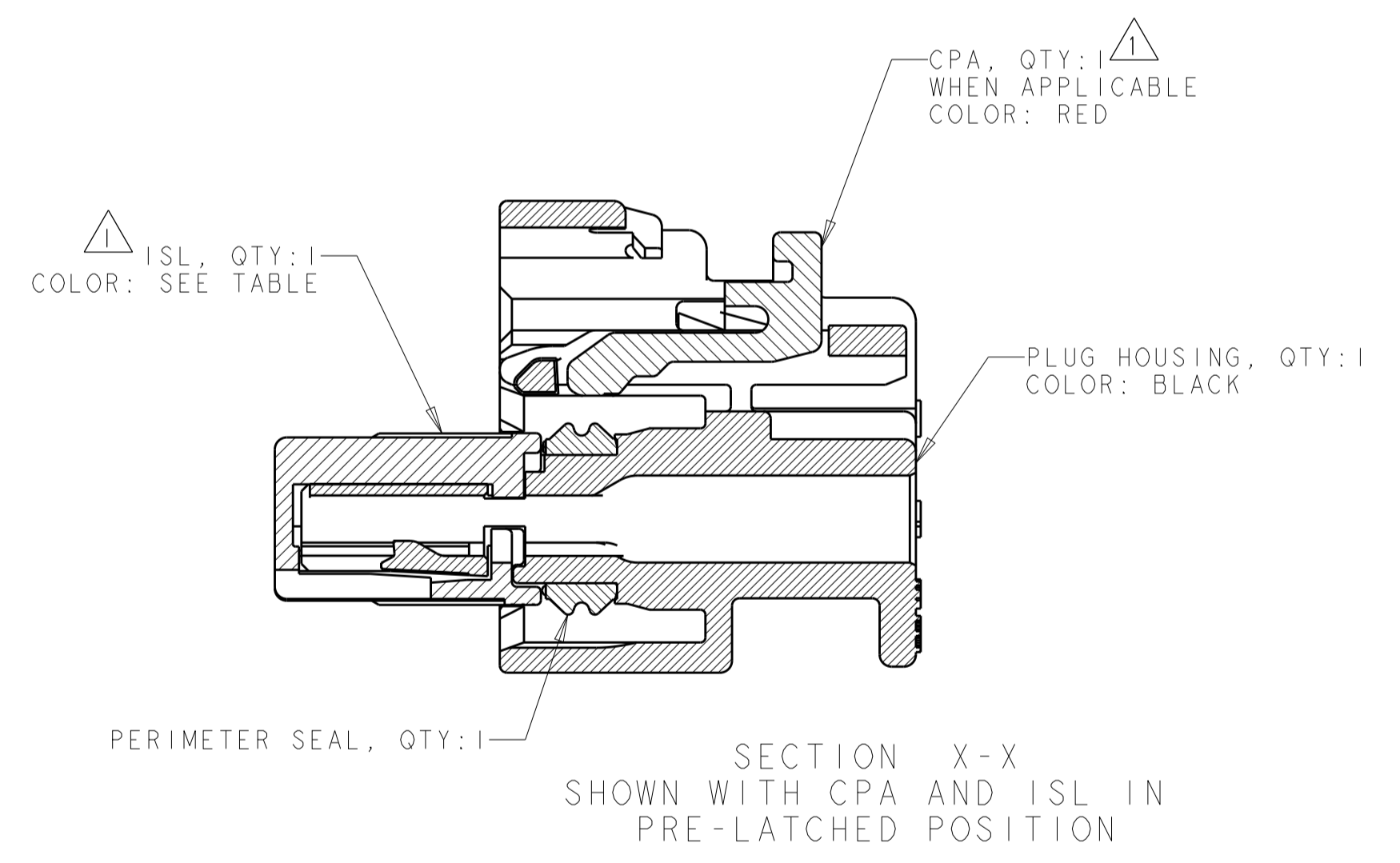

SECTION X-X SHOWN WITH CPA AND ISL IN PRE-LATCHED POSITION

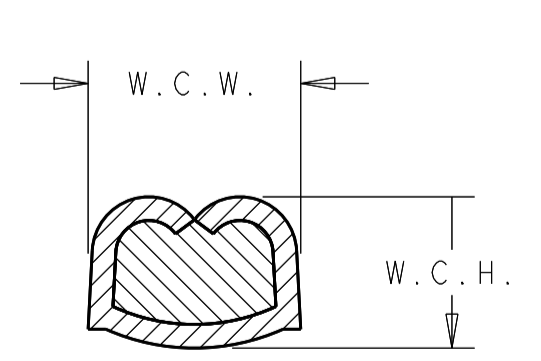

WIRE CRIMP DIMENSIONS

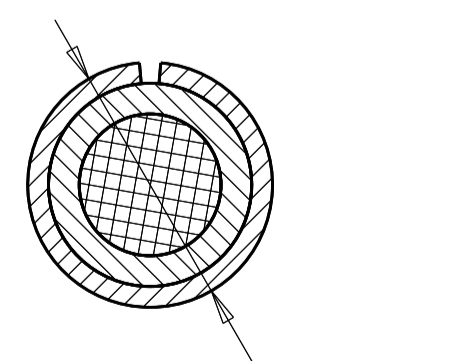

INSULATION CRIMP DIMENSIONS

- △ ISL AND CPA (WHEN APPLICABLE) ARE SHIPPED IN THEIR PRE-LATCHED POSITIONS.
- 2. TERMINALS SOLD SEPARATELY. FOR USE WITH TE MCON 1.2mm CLEAN BODY CONTACT WITH WIRE SEAL. SEE TABLE.
- 3. APPLICABLE INTERFACE DRAWINGS: EWCAP 120-S-004-1-Z01 AND 120-S-004-1-Z02.
- △ MINIMUM FEED THROUGH CONDITION WITH 1.0mm CLEARANCE ALL AROUND.
- 5. TRACEABILITY CODE (YY = TWO DIGIT YEAR, JJJ = 3 DIGIT JULIAN DAY, S = 1 DIGIT SHIFT).
- 6. FOR OPTIONAL TERMINAL CAVITY BLOCKING, CONTACT TE SALES REPRESENTATIVE OR CUSTOMER SERVICE.
- △ SEE INSTRUCTION SHEET 408-32103 FOR CONNECTOR SERVICE AND ISL OPERATION. ISL ACTUATION DISTANCE IS 2.0mm.
- △ CONTACT PLATING AND APPLICABLE INDIVIDUAL WIRE SEAL ARE APPLICATION DEPENDENT. CONTACT TE SALES REPRESENTATIVE OR CUSTOMER SERVICE FOR DETAILS.
- △ FOR WIRE CRIMP DETAILS, SEE TE APPLICATION SPECIFICATION 114-18464.
- △ DOCUMENTED I.C.D. IS SPECIFIED TO MEET MOST WIRE SEAL APPLICATIONS. HOWEVER, I.C.D. IS HIGHLY DEPENDENT ON INSULATION TYPE AND OD. SUFFICIENT GRIP OF THE WIRE SEAL MUST BE OBTAINED SUCH THAT WIRE SEAL DOES NOT DISPLACE FROM INSULATION GRIP DURING CONTACT INSERTION INTO CONNECTOR HOUSING. THE WIRE SEAL SHALL NOT BE CRIMPED TOO TIGHTLY THAT THE WIRE SEAL TEARS DURING THE CRIMPING OPERATION.
- 11. CONNECTOR VALIDATION TO PER USCAR-2 (REV 6) T4,V4,S3.
- △ KEY CODE DIMENSIONS ARE SHOWN WITH ISL IN PRE-LATCHED POSITION. FOR DIMENSION OF KEY WITH ISL IN FINAL POSITION, ADJUST SHOWN DIMENSIONS BY 2.0mm.
- △ PRELIMINARY - NOT RELEASED FOR PRODUCTION
- △ KEY CODE NOT TOOLED
- 15. MATES WITH STRAIGHT EXIT WIRE DRESS, TE PN 2272162-1 AND RIGHT ANGLE EXIT WIRE DRESS, TE PN 2272163-1

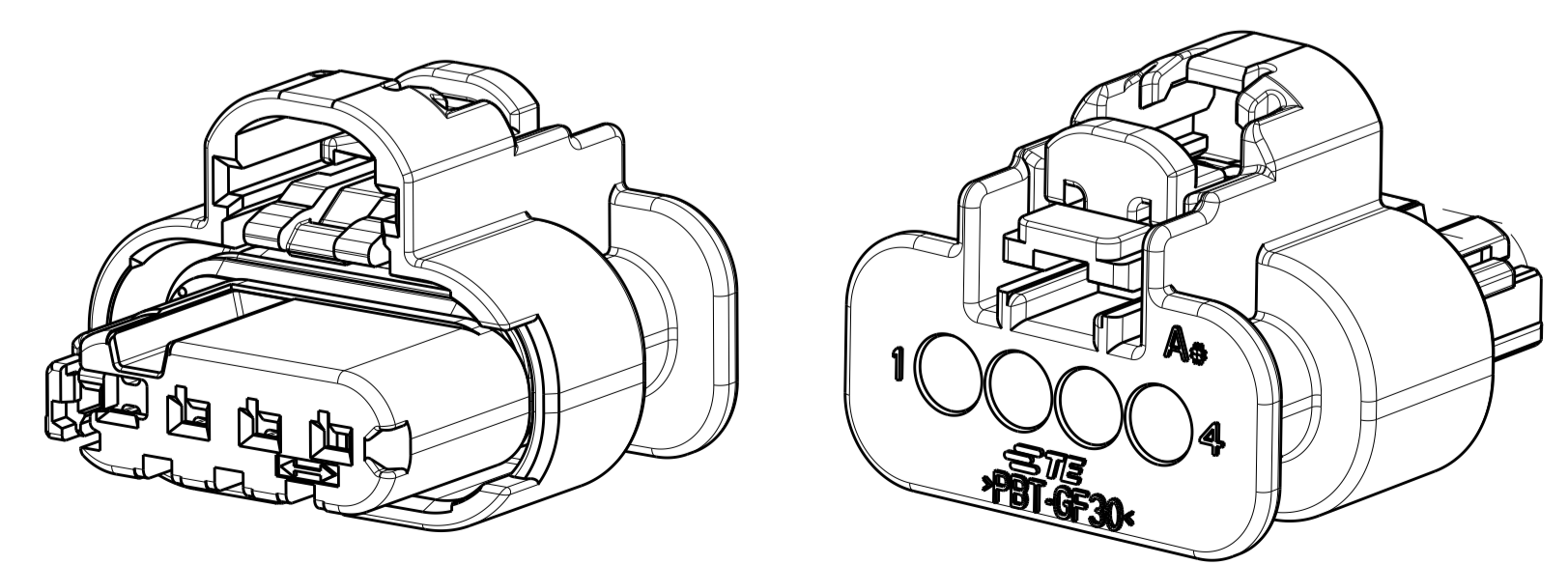

ISOMETRIC VIEW SCALE 3:1

ISL COLOR	KEYING CONFIGURATION	PART NUMBER
BLUE	KEY CODE G	1-2203773-7
DK GRAY	KEY CODE F	1-2203773-6
LT GRAY	KEY CODE E	1-2203773-5
BLUE	KEY CODE D	1-2203773-4
DK GRAY	KEY CODE C	1-2203773-3
LT GRAY	KEY CODE B	1-2203773-2
BLUE	KEY CODE A	1-2203773-1
CPA (YES / NO)	ISL COLOR	KEYING CONFIGURATION
YES	BLUE	KEY CODE G
YES	DK GRAY	KEY CODE F
YES	LT GRAY	KEY CODE E
YES	BLUE	KEY CODE D
YES	DK GRAY	KEY CODE C
YES	LT GRAY	KEY CODE B
YES	BLUE	KEY CODE A
NO	BLUE	KEY CODE G
NO	DK GRAY	KEY CODE F
NO	LT GRAY	KEY CODE E
NO	BLUE	KEY CODE D
NO	DK GRAY	KEY CODE C
NO	LT GRAY	KEY CODE B
NO	BLUE	KEY CODE A

150°C	1418844	△	△	△	△
△	1670146				
	1418850				
MAX TEMP	FEMALE TERMINAL P/N	W.C.H	W.C.W	I.C.D	WIRE SEAL PART NUMBER

THIS DRAWING IS A CONTROLLED DOCUMENT. DIMENSIONS: mm. TOLERANCES UNLESS OTHERWISE SPECIFIED: 0 PLC ±0.3, 1 PLC ±0.3, 2 PLC ±0.15, 3 PLC ±, 4 PLC ±, ANGLES FINISH ±.

OWN: VISHNU.P 27MAY2013
CHK: MD BROWN 29MAY2013
APP'D: MD BROWN 29MAY2013

STE TE Connectivity

NAME: PLUG ASSEMBLY, SEALED, 4 POSITION, MCON

SIZE: CAGE CODE DRAWING NO: A100779
SCALE: 4:1 SHEET 1 OF 1 REV: A3