

LTC3307B

3.3V to 1.8V at 3A, 6.6MHz Low EMI Buck Regulator in a 0.47cm² Solution

DESCRIPTION

Demonstration circuit 3054A-A features the [LTC®3307B](#) 5V, 3A synchronous step-down Silent Switcher® operating as a 6.6MHz, 3.3V to 1.8V 3A buck regulator. The LTC3307B supports adjustable output voltages from 0.5V to V_{IN} , and operating frequencies from 3MHz up to 10MHz. The LTC3307B is a compact, ultralow emission, high efficiency, and high speed synchronous monolithic step-down switching regulator. A minimum on-time of 22ns enables high V_{IN} to low V_{OUT} conversion ratios at high switching frequencies.

The DC3054A-A operating mode may be selected as Burst Mode® operation, skip or forced continuous (FC) mode. Setting JP1 to the FC/SYNC position will allow the LTC3307B to sync to a clock frequency from 3MHz to 10MHz. The LTC3307B operates in forced continuous mode when syncing to an external clock. The DC3054A-A is set to a fixed 6.6MHz.

The DC3054A-A is set to a fixed 6.6MHz frequency by connecting RT to V_{IN} through a 0Ω resistor, R9. The frequency can be easily changed by removing R9 and setting an appropriate resistor in the R4 location to obtain the desired frequency. Refer to the LTC3307B data sheet for the proper R_T value for a desired switching frequency.

The DC3054A-A also has an EMI filter to reduce conducted EMI. This EMI filter can be included by applying the input voltage at the V_{IN} EMI terminal. The EMI performance of the board is shown in the EMI Test Results section. The red lines in the EMI performance graphs illustrate the CISPR25 Class 5 peak limits for the conducted and radiated emission tests.

The LTC3307B data sheet gives a complete description of the device, operation and application information. The data sheet must be read in conjunction with this demo manual. The LTC3307B is assembled in a 2mm × 2mm LQFN package with exposed pads for low thermal resistance. The layout recommendations for low EMI operation and maximum thermal performance are available in the data sheet section Low EMI PCB Layout.

The Efficiency vs Load graph shows the efficiency and the power loss of the circuit with a 3.3V input in Burst Mode operation.

[Design files for this circuit board are available.](#)

All registered trademarks and trademarks are the property of their respective owners.

PERFORMANCE SUMMARY Specifications are at $T_A = 25^\circ\text{C}$

SYMBOL	PARAMETER	CONDITIONS	MIN	TYP	MAX	UNITS
V_{IN}	Input Voltage Range		2.25		5.5	V
V_{OUT}	V_{OUT} Voltage Range*		1.774	1.8	1.826	V
I_{OUT}	OUTPUT Current				3	A
f_{SW}	Switching Frequency		3	6.6	10	MHz
t_{ON}	Top Switch Minimum On Time			22		ns
Duty Cycle	Top Switch Duty Cycle				100	%

*With 1% resistors. Accuracy will improve to within 1% using 0.1% FB resistors.

BOARD PHOTO

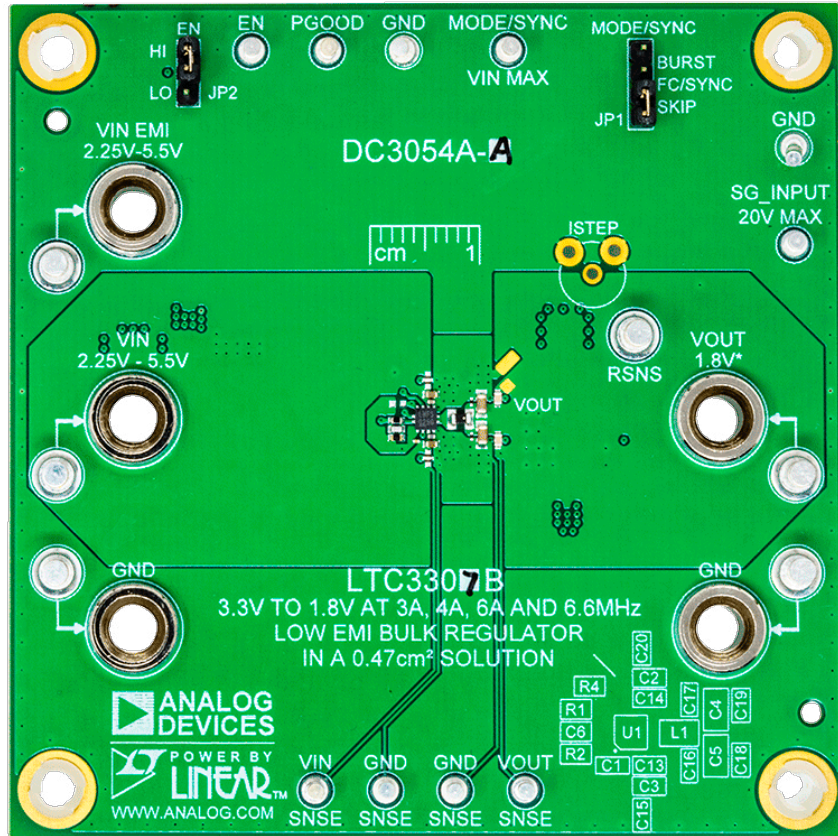

CIRCUIT SCHEMATIC

High Efficiency, 6.6MHz, 1.8V 3A Step-Down Converter

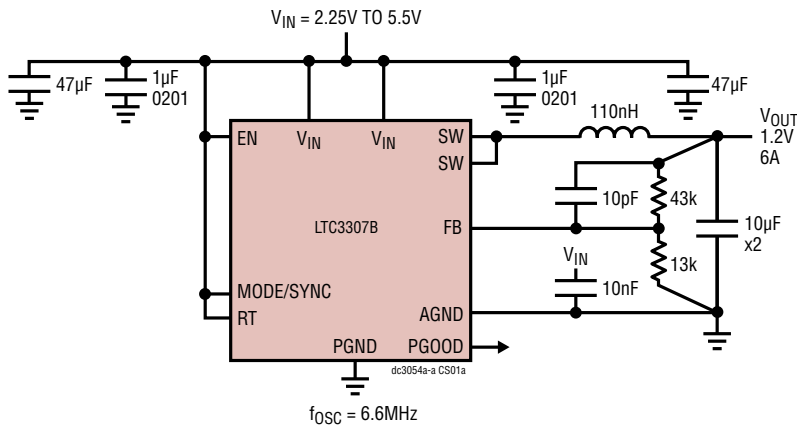

LTC3307B 3.3V to 1.8V Efficiency and Power Loss DC3054A-A in Burst Mode

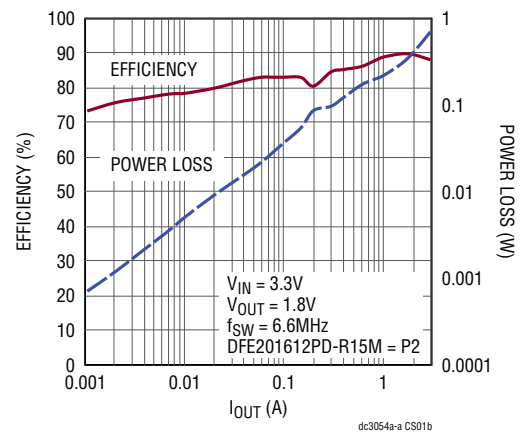

EMI TEST RESULTS

CISPR25 Conducted Emissions with Class 5 Peak Limits (Voltage Method)

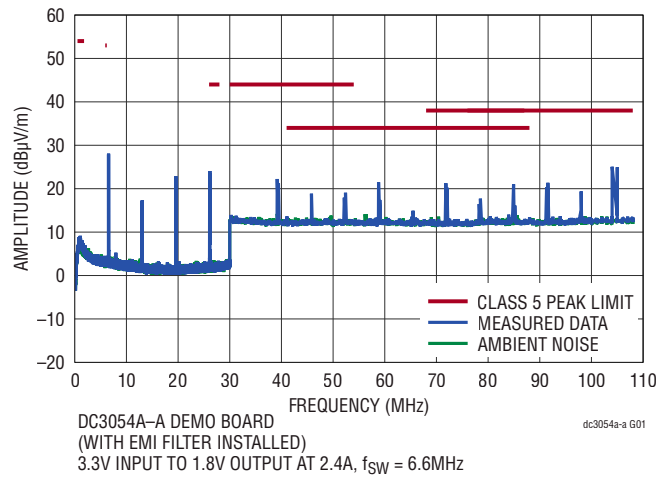

Radiated EMI Performance (CISPR25 Radiated Emissions Test with Class 5 Peak Limits)

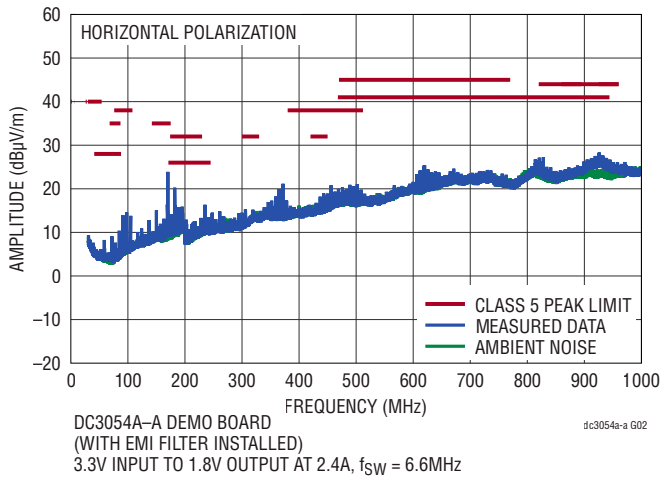

Radiated EMI Performance (CISPR25 Radiated Emissions Test with Class 5 Peak Limits)

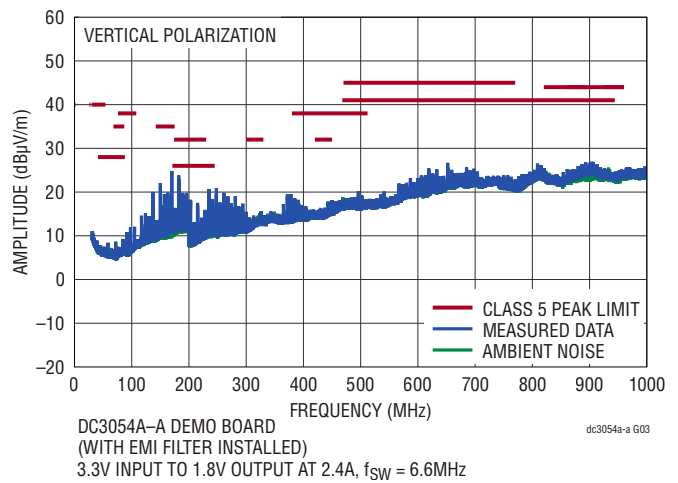

Load Transient Response Forced Continuous Mode

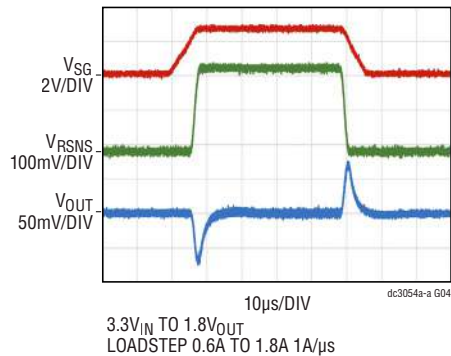

LTC3307B Load Regulation

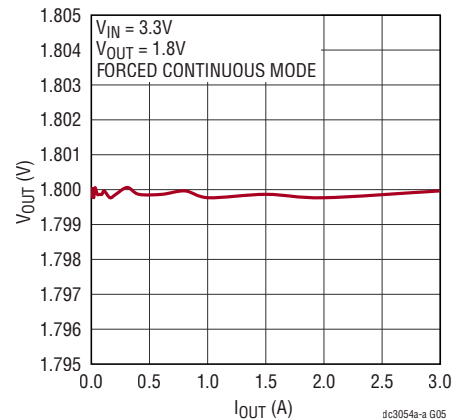

QUICK START PROCEDURE

Demonstration circuit 3054A-A is easy to set up and use to evaluate the performance of the LTC3307B. Refer to Figure 1 for proper measurement equipment setup and follow the procedure below:

NOTE: For accurate V_{IN} , V_{OUT} and efficiency measurements, measure V_{IN} at the V_{IN} SNSE and GND SNSE turrets and V_{OUT} at the V_{OUT} SNSE and GND SNSE turrets as illustrated as VM1 and VM2 in Figure 1. When measuring the input or output voltage ripple, care must be taken to avoid a long ground lead on the oscilloscope probe.

1. Set the JP1 Jumper to the SKIP position and JP2 to the HI position.
2. With power off, connect the input power supply to V_{IN} and GND. If the input EMI filter is desired, connect the input power supply to V_{IN} EMI.
3. Slowly increase PS1 to 1.0V. If AM1 reads less than 20mA, increase PS1 to 3.3V. Verify that VM1 reads 3.3V and VM2 reads 1.8V.
4. Connect an oscilloscope voltage probe as shown in Figure 2 in parallel with VM2. Set Channel to AC-coupled, voltage scale to 20mV and time base to 100ns. Observe the V_{OUT} ripple voltage.

NOTE: Measure the output voltage ripple by touching the probe tip directly across the output turrets or to TP1 as shown in Figure 2. TP1 is designed for a 50 Ω coax cable to reduce any high frequency noise that might couple into the oscilloscope probes.

5. Verify that PGOOD turret is high.
6. Increasing the load by 1A intervals up to 3A and record VM1, VM2, AM1 and AM2 for each interval.
7. Repeat step 6 for PS1 set to 2.5V and again for PS1 set to 5.0V.
8. Set the load to a constant 3A. Remove the oscilloscope voltage probe from V_{OUT} . Place a ground clip on PGND terminal and set the voltage scale to 1V and the time scale to 500ns/Division. Trigger on the rising edge of the voltage probe. Using a tip on the voltage probe, contact the SW node on the pad of L1. Observe the duty cycle and the period of the switching waveform (~152nanoseconds).

9. Set the load current to 0.5A and repeat step 8. Observe that the switching waveform is now operating in Pulse Skip Mode.
10. Move the jumper on JP2 to LO. Verify that V_{OUT} reads 0V and verify that PGOOD is low. Return jumper on JP2 to HI and verify VM2 is 1.8V and verify PGOOD2 is high.
11. If forced continuous or Burst Mode operation is desired, set PS1 to 0V. Move JP1 to FC/SYNC or BURST. Repeat steps 3 through 9. In step 9 observe that the switching waveform is now operating in forced continuous or Burst Mode operation.
12. To change the frequency, remove R9 if installed. Install the desired R_T resistor in the R4 location. Size the inductor and output capacitors to provide the desired inductor ripple and a stable output. Refer to the LTC3307B data sheet and [LTPowerCAD](#) for more information on choosing the required components.
13. To test the transient response with a base load, add the desired resistor to produce a minimum load between V_{OUT} and RSNS turrets (R_L shown on Figure 1). Note that the total load resistance will be R_L plus R11 (100m Ω).
14. Adjust a signal generator with a 10ms period, 10% duty cycle and an amplitude from 1V to 2V to start.
15. Measure the RSNS voltage to observe the current, $V_{RSNS}/100m\Omega$. Adjust the amplitude of the pulse to provide the desired transient. Adjust the rising and falling edge of the pulse to provide the desired ramp rate. Refer to the following equations and the optional transient response circuit shown in Figure 3:

$$I_{OUT} = V_{RSNS}/100m\Omega \quad (2)$$

where

$$V_{RSNS} = V_{SG_INPUT} - V_{GS} \quad (3)$$

16. When done, turn off PS1 and Load. Remove all connections to demo board.

QUICK START PROCEDURE

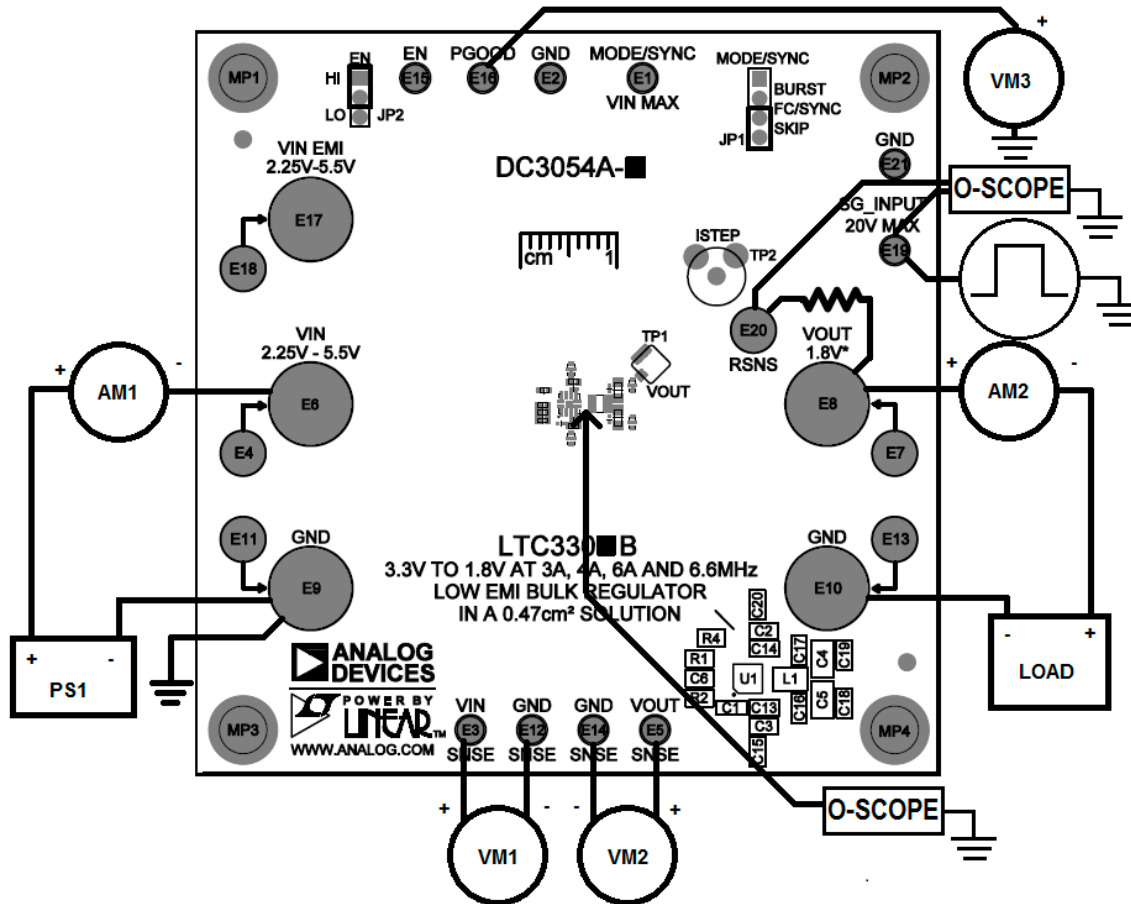

Figure 1. Test Setup for the DC3054A-A Demo Board

QUICK START PROCEDURE

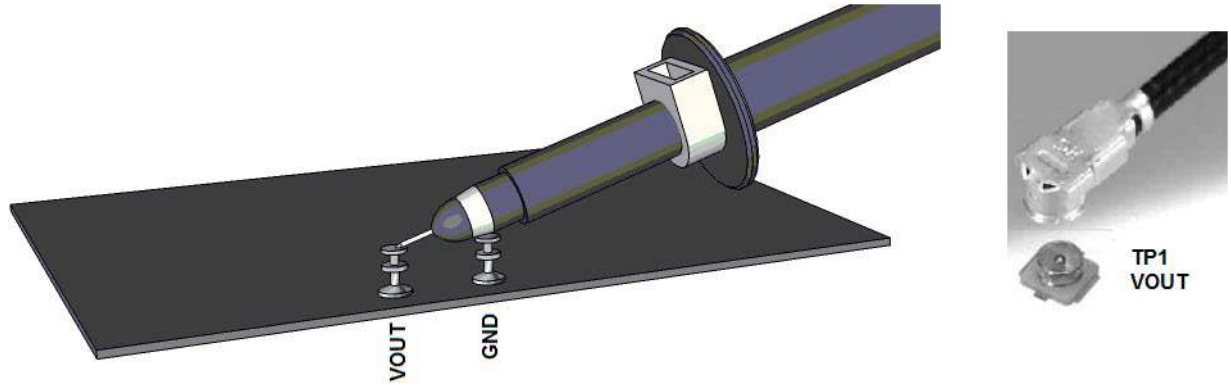

Figure 2. Technique for Measuring Output Ripple and Step Response
a) With a Scope Probe.
b) With a Low Inductance Connector (Not Supplied).

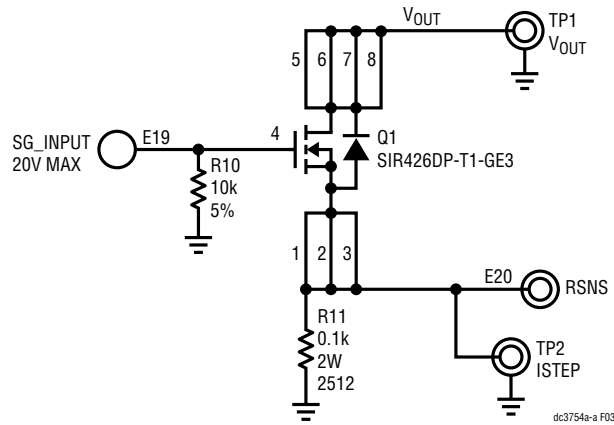

Figure 3. Optional Transient Response Circuit

THEORY OF OPERATION

Introduction to the DC3054A-A

The DC3054A-A demonstration circuit features the LTC3307B, a low voltage synchronous step-down silent switcher. The LTC3307B is a monolithic, constant frequency, current mode step-down DC/DC converter. An oscillator, with frequency set using a resistor on the RT pin, turns on the internal top power switch at the beginning of each clock cycle. Current in the inductor then increases until the top switch comparator trips and turns off the top power switch. If the EN pin is low, the LTC3307B is in shutdown and in a low quiescent current state. When the EN pin is above its threshold, the switching regulator will be enabled.

The MODE/SYNC pin sets the switching mode to pulse skip, forced continuous, or Burst Mode operation. If an external 3MHz to 10MHz clock is connected to the MODE/SYNC turret while the JP1 is set to the FC/SYNC position, the LTC3307B switching frequency will sync to the external clock while operating in forced continuous mode. See the LTC3307B data sheet for more detailed information.

The maximum allowable operating frequency is influenced by the minimum on time of the top switch, the ratio of V_{OUT} to V_{IN} . The maximum allowable operating frequency may be calculated using a minimum t_{ON} of 22ns in the formula below.

$$f_{SW(MAX)} = \frac{V_{OUT}}{V_{IN(MAX)} \cdot t_{ON(MIN)}}$$

Select an operating switching frequency below $f_{SW(MAX)}$. The recommended ripple current in the output inductor is 0.9A peak-to-peak for the LTC3307B. This determines the recommended inductor value for the application.

Accurately Measuring Output Ripple of the LTC3307B

With the fast edge rates of the circuit, high frequency noise can be observed when measuring the output voltage with 1M Ω terminated oscilloscope probes. To better view the output ripple with oscilloscopes of 400MHz bandwidth and above a 50 Ω coax cable connected as close to the output caps as possible should be used with the oscilloscope channel terminated to 50 Ω at the scope. This will help to reduce the noise coupling onto and displaying on

the scope. The demo board is set up to solder an U.FL, RECEIPT, ST SMD, 0Hz to 6GHz 50 Ω connector (TP1) near the output cap C4. These pads can also be used to solder a coax cable or other oscilloscope probe connector if desired.

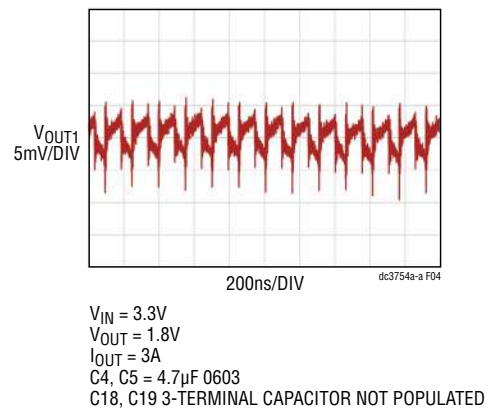

Figure 4.

The DC3054A-A uses 3-terminal capacitors, C18 and C19, on the output to reduce the high frequency spikes that can be observed with high bandwidth oscilloscopes. The high frequency spikes are partially attributed to the interwinding capacitance of the inductor and the voltage step is partially attributed to the inductance in the output capacitors. The step can be reduced by choosing low ESL capacitors as close to the inductor as possible. The high frequency spikes are reduced with using a small low ESL 3-terminal capacitor with the self-resonant frequency close to the high frequency spikes. Below is the output ripple using a 500MHz scope, 50 Ω probe measured at TP1 on without the 3-terminal capacitor populated in C19.

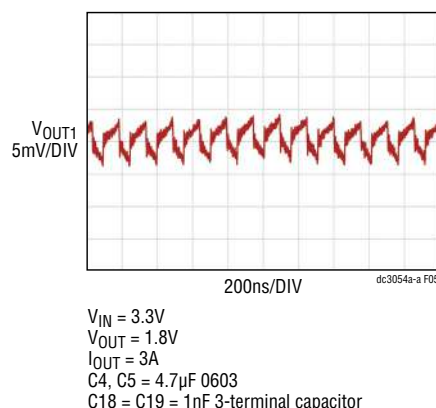

Figure 5.

DEMO MANUAL

DC3054A-A

PARTS LIST

ITEM	QTY	REFERENCE	PART DESCRIPTION	MANUFACTURER/PART NUMBER
Required Circuit Components				
1	2	C2, C3	CAP, 4.7uF, X6S, 6.3V, 20%, 0402	MURATA, GRM155C80J475MEAAD
2	2	C4, C5	CAP, 4.7uF X7R, 16V, 10%, 0603	MURATA, GRM188Z71C475KE21
3	1	C6	CAP, 10pF, C0G, 50V, 5%, 0402	MURATA, GJM1555C1H100JB01D
4	2	C13, C14	CAP, 1uF, X7T, 6.3V, 20%, 0201	MURATA, GRM033D70J105ME01D
5	1	L1	IND., 240nH, PWR, 20%, 3.5A, 30mOHM, 0603	MURATA, DFE18SANR24MG0L
6	1	R1	RES., 47.5k OHMS, 1%, 1/16W, 0402	VISHAY, CRCW040247K5FKED
7	1	R2	RES., 18.2k OHMS, 1%, 1/16W, 0402, AEC-Q200	VISHAY, CRCW040218K2FKED
8	1	U1	IC, 5V, 3A Synchronous Step-Down Silent Switcher, 2x2mm LQFN	ANALOG DEVICES, LTC3307BEV#PBF
Additional Demo Board Circuit Components				
1	1	C1	CAP, 0.01uF, X5R, 10V, 10%, 0201	MURATA, GRM033R61A103KA01D
2	2	C7, C8	CAP, 330uF, TANT, POSCAP 6.3V, 20%, 7343, 25mOHMS, TPE, NO SUBS. ALLOWED	PANASONIC, 6TPE330ML
3	1	C9	CAP, 0.1uF X7R, 10V, 10%, 0402, AEC-Q200	MURATA, GCM155R71A104KA55D
4	2	C10, C11	CAP, 10uF, X7S, 6.3V, 20%, 0603	TDK, C1608X7S0J106M080AC
5	0	C12	CAP, OPTION, 0402	
6	2	C18, C19	CAP, 1000pF, X7R, 50V, 20%, 0402, 3-TERM, X2Y EMI FILTER	JOHANSON DIELECTRICS, 500X07W102MV4T
7	0	C15, C20	CAP, 1000pF, X7R, 50V, 20%, 0402, 3-TERM, X2Y EMI FILTER	JOHANSON DIELECTRICS, 500X07W102MV4T
8	0	C16, C17	CAP, OPTION, 0201	
9	1	L2	IND., 100 OHMS@100MHz, FERRITE BEAD, 25%, 8A, 6mOHMS, 1812	WURTH ELEKTRONIK, 74279226101
10	1	Q1	XSTR., MOSFET, N-CH, 40V, 15.9A, PPAK SO-8	VISHAY, SIR426DP-T1-GE3
11	1	R3	RES., 20 OHMS, 1%, 1/16W, 0402, AEC-Q200	NIC, NRC04F20R0TRF
12	0	R4	RES., OPTION, 0402	
13	1	R5	RES., 10k OHMS, 5%, 1/16W, 0402, AEC-Q200	VISHAY, CRCW040210K0JNED
14	1	R6	RES., 1M OHMS, 1%, 1/16W, 0402, AEC-Q200	VISHAY, CRCW04021M00FKED
15	1	R7	RES., 249k OHMS, 1%, 1/16W, 0402, AEC-Q200	NIC, NRC04F2493TRF
16	1	R8	RES., 100k OHMS, 5%, 1/16W, 0402	YAGEO, RC0402JR-07100KL
17	1	R9	RES., 0 OHM, 1/16W, 0402	VISHAY, CRCW04020000Z0ED
18	1	R10	RES., 10k OHMS, 5%, 1/10W, 0402, AEC-Q200	PANASONIC, ERJ2GEJ103X
19	1	R11	RES., 0.1 OHM, 1%, 2W, 2512, SENSE, AEC-Q200	IRC, LRC-LR2512LF-01-R100-F
20	0	TP1, TP3	CONN., U.FL, RECEIPT, ST SMD, 0Hz to 6GHz 500hm	HIROSE ELECTRIC, U.FL-R-SMT-1(10)
Hardware				
1	10	E1-E3, E5, E12, E14-E16, E19, E21	TEST POINT, TURRET, 0.064" MTG. HOLE, PCB 0.062" THK	MILL-MAX, 2308-2-00-80-00-00-07-0
2	6	E4, E7, E11, E13, E18, E20	TEST POINT, TURRET, 0.094" MTG. HOLE, PCB 0.062" THK	MILL-MAX, 2501-2-00-80-00-00-07-0
3	5	E6, E8-E10, E17	CONN., BANANA JACK, FEMALE, THT, NON-INSULATED, SWAGE, 0.218"	KEystone, 575-4
4	1	JP1	CONN., HDR, MALE, 1x4, 2mm, VERT, ST, THT	WURTH ELEKTRONIK, 62000411121
5	1	JP2	CONN., HDR, MALE, 1x3, 2mm, VERT, ST, THT	WURTH ELEKTRONIK, 62000311121
6	4	MP1-MP4	STANDOFF, NYLON, SNAP-ON, 0.50"	WURTH ELEKTRONIK, 702935000
7	0	TP2	CONN., TEST JACK, PLUG, 1POS, THT, VERT	TELEDYNE, PK5-2.5MM-113
8	2	XJP1, XJP2	CONN., SHUNT, FEMALE, 2 POS, 2mm	WURTH ELEKTRONIK, 60800213421

SCHEMATIC DIAGRAM

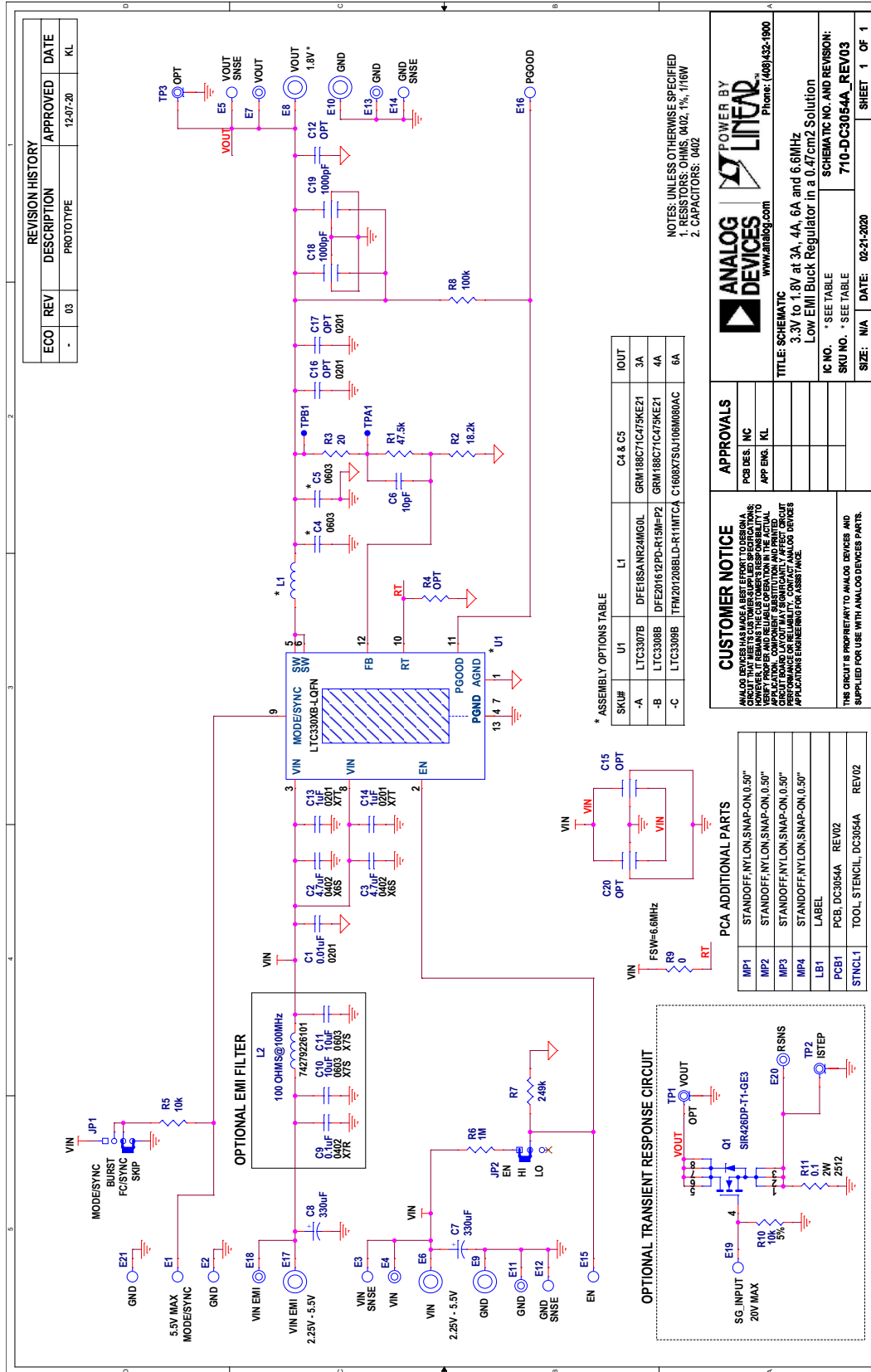



ESD Caution

ESD (electrostatic discharge) sensitive device. Charged devices and circuit boards can discharge without detection. Although this product features patented or proprietary protection circuitry, damage may occur on devices subjected to high energy ESD. Therefore, proper ESD precautions should be taken to avoid performance degradation or loss of functionality.

Legal Terms and Conditions

By using the evaluation board discussed herein (together with any tools, components documentation or support materials, the "Evaluation Board"), you are agreeing to be bound by the terms and conditions set forth below ("Agreement") unless you have purchased the Evaluation Board, in which case the Analog Devices Standard Terms and Conditions of Sale shall govern. Do not use the Evaluation Board until you have read and agreed to the Agreement. Your use of the Evaluation Board shall signify your acceptance of the Agreement. This Agreement is made by and between you ("Customer") and Analog Devices, Inc. ("ADI"), with its principal place of business at One Technology Way, Norwood, MA 02062, USA. Subject to the terms and conditions of the Agreement, ADI hereby grants to Customer a free, limited, personal, temporary, non-exclusive, non-sublicensable, non-transferable license to use the Evaluation Board FOR EVALUATION PURPOSES ONLY. Customer understands and agrees that the Evaluation Board is provided for the sole and exclusive purpose referenced above, and agrees not to use the Evaluation Board for any other purpose. Furthermore, the license granted is expressly made subject to the following additional limitations: Customer shall not (i) rent, lease, display, sell, transfer, assign, sublicense, or distribute the Evaluation Board; and (ii) permit any Third Party to access the Evaluation Board. As used herein, the term "Third Party" includes any entity other than ADI, Customer, their employees, affiliates and in-house consultants. The Evaluation Board is NOT sold to Customer; all rights not expressly granted herein, including ownership of the Evaluation Board, are reserved by ADI. CONFIDENTIALITY. This Agreement and the Evaluation Board shall all be considered the confidential and proprietary information of ADI. Customer may not disclose or transfer any portion of the Evaluation Board to any other party for any reason. Upon discontinuation of use of the Evaluation Board or termination of this Agreement, Customer agrees to promptly return the Evaluation Board to ADI. ADDITIONAL RESTRICTIONS. Customer may not disassemble, decompile or reverse engineer chips on the Evaluation Board. Customer shall inform ADI of any occurred damages or any modifications or alterations it makes to the Evaluation Board, including but not limited to soldering or any other activity that affects the material content of the Evaluation Board. Modifications to the Evaluation Board must comply with applicable law, including but not limited to the RoHS Directive. TERMINATION. ADI may terminate this Agreement at any time upon giving written notice to Customer. Customer agrees to return to ADI the Evaluation Board at that time. LIMITATION OF LIABILITY. THE EVALUATION BOARD PROVIDED HEREUNDER IS PROVIDED "AS IS" AND ADI MAKES NO WARRANTIES OR REPRESENTATIONS OF ANY KIND WITH RESPECT TO IT. ADI SPECIFICALLY DISCLAIMS ANY REPRESENTATIONS, ENDORSEMENTS, GUARANTEES, OR WARRANTIES, EXPRESS OR IMPLIED, RELATED TO THE EVALUATION BOARD INCLUDING, BUT NOT LIMITED TO, THE IMPLIED WARRANTY OF MERCHANTABILITY, TITLE, FITNESS FOR A PARTICULAR PURPOSE OR NON-INFRINGEMENT OF INTELLECTUAL PROPERTY RIGHTS. IN NO EVENT WILL ADI AND ITS LICENSORS BE LIABLE FOR ANY INCIDENTAL, SPECIAL, INDIRECT, OR CONSEQUENTIAL DAMAGES RESULTING FROM CUSTOMER'S POSSESSION OR USE OF THE EVALUATION BOARD, INCLUDING BUT NOT LIMITED TO LOST PROFITS, DELAY COSTS, LABOR COSTS OR LOSS OF GOODWILL. ADI'S TOTAL LIABILITY FROM ANY AND ALL CAUSES SHALL BE LIMITED TO THE AMOUNT OF ONE HUNDRED US DOLLARS (\$100.00). EXPORT. Customer agrees that it will not directly or indirectly export the Evaluation Board to another country, and that it will comply with all applicable United States federal laws and regulations relating to exports. GOVERNING LAW. This Agreement shall be governed by and construed in accordance with the substantive laws of the Commonwealth of Massachusetts (excluding conflict of law rules). Any legal action regarding this Agreement will be heard in the state or federal courts having jurisdiction in Suffolk County, Massachusetts, and Customer hereby submits to the personal jurisdiction and venue of such courts. The United Nations Convention on Contracts for the International Sale of Goods shall not apply to this Agreement and is expressly disclaimed.