

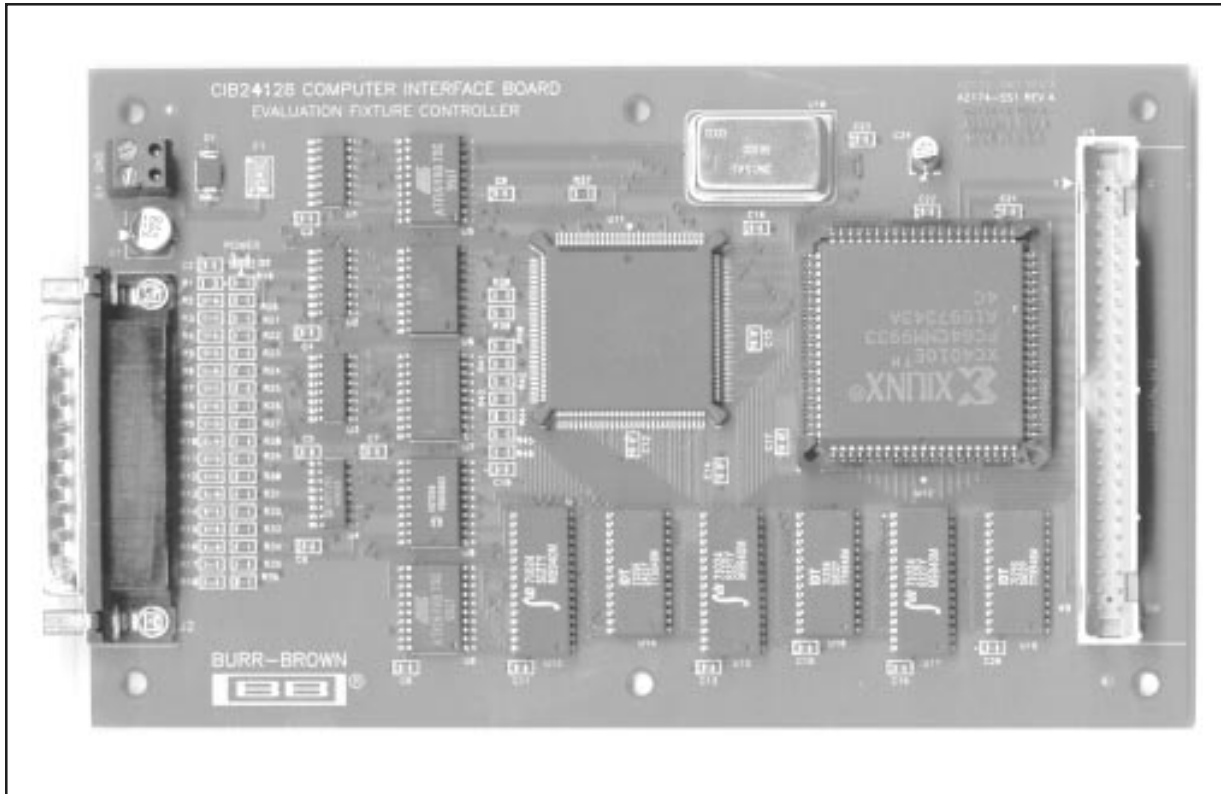

DEM-CIB EVALUATION FIXTURE COMPUTER INTERFACE BOARD



FEATURES

- CONTROL BOARD FOR BURR-BROWN EVALUATION BOARDS
- ON-BOARD DSP AND XILINX PROGRAMMABLE LOGIC DEVICE ARE PROGRAMMED FROM HOST COMPUTER
- EASY INTERFACE TO PC-COMPATIBLE COMPUTER VIA PARALLEL PORT
- INTERFACES TO EVALUATION BOARDS VIA INCLUDED 50-PIN RIBBON CABLE
- BBEVAL EVALUATION SOFTWARE INCLUDED FOR DATA ANALYSIS
- INCLUDES TIME DOMAIN, FFT, AND HISTOGRAM-ANALYSIS CAPABILITIES FOR ADC EVALUATION
- MICROSOFT WINDOWS® 95/98 COMPATIBLE

DESCRIPTION

The DEM-CIB computer interface board is a development and evaluation tool that interfaces Burr-Brown analog-to-digital and digital-to-analog demonstration and evaluation fixtures to a PC-compatible computer. The DEM-CIB is the interface between the PC and a daughter evaluation board which is device specific. See Figure 1, a block diagram of the DEM-CIB.

The control software for the DEM-CIB is downloaded from the PC to the DEM-CIB, and is then run on this board. Each evaluation board comes with its own software drivers for the DEM-CIB.

Included with the DEM-CIB is BBEval, a powerful data analysis package which allows time domain, frequency domain, and histogram testing of A/D converters.

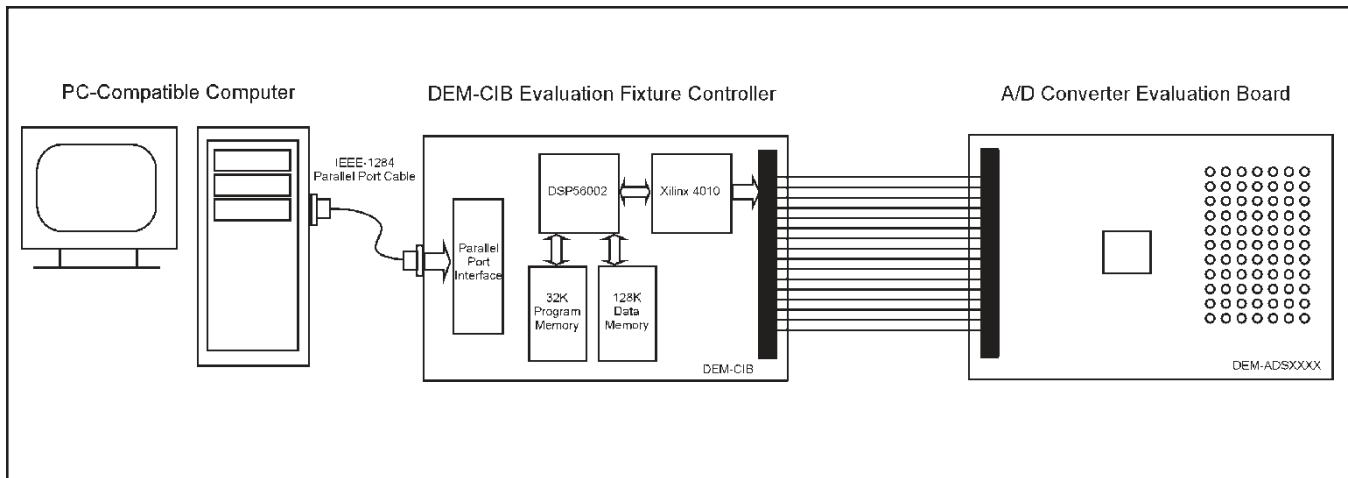

FIGURE 1. DEM-CIB Setup and Block Diagram.

DEM-CIB KIT CONTENTS

The DEM-CIB contains the following:

- Evaluation Fixture Controller Board
- IEEE-1284 Parallel Port Cable
- 50-pin Ribbon Cable
- BBEval Software CD
- This Data Sheet

The BBEval software CD includes all the software needed to setup and use the DEM-CIB. Documentation for the BBEval software is included in help files on the disk.

EQUIPMENT NEEDED

To use the DEM-CIB and the BBEval software, the following equipment is required:

- A PC-Compatible Computer Running Windows 95 or Windows 98
- A +5V DC Power Supply
- Evaluation Board for Device to Test

SETUP AND INSTALLATION

Hardware Setup

Unpack the kit contents and verify that you have received everything listed in the section titled “DEM-CIB Kit Contents”.

Connect a +5V DC power supply to the DEM-CIB. The DEM-CIB utilizes a removable terminal-block connector. Place the ends of wires from the power supply into the connector and tighten down the set screws, making sure you have connected the power supply wires with the correct polarity, as marked on the DEM-CIB board. When you are sure that the power supply is connected correctly, turn on the +5V power supply. A small LED should light on the DEM-CIB, indicating that it has power.

Connect the DEM-CIB to your computer with the included IEEE-1284 cable. Due to the high speeds of data communicated across this link, do not use any parallel cable other than an IEEE-1284 cable.

If you have an evaluation board which you wish to use with the DEM-CIB, connect it to the DEM-CIB board using the 50-pin ribbon cable supplied with the DEM-CIB. Each evaluation board requires different power supplies, depending upon the device for which the evaluation board is designed. Make sure you connect appropriate supplies to the evaluation board.

Software Installation

Insert the BBEval CD into your computer’s CD-ROM drive. The installer should start automatically; if not, run the program “Setup.exe” from the CD.

Follow the instructions and prompts in the installer to install the BBEval software on your computer.

USING THE BBEVAL SOFTWARE

To begin using BBEval, launch the program by going to the Start menu, select BBEval, and click on Burr-Brown Evaluation System.

BBEval will start up. This software package tests A/D converters in the time or frequency domains, and performs histogram testing on them, allowing for quick evaluation and testing of an A/D converter.

A few drivers for A/D converter evaluation fixtures are installed by default with BBEval (new evaluation fixtures come with their own drivers which must be installed separately using the installer included on the evaluation kit disk). However, you can try out BBEval without an evaluation fixture. BBEval allows you to use synthetic data which it generates, so that you may become familiar with the program and its capabilities.

To learn more details about BBEval and how to use it, see the Help Topics under the Help menu in the program.

See Figure 2 for a screen shot of BBEval after performing an FFT analysis on Synthetic data.

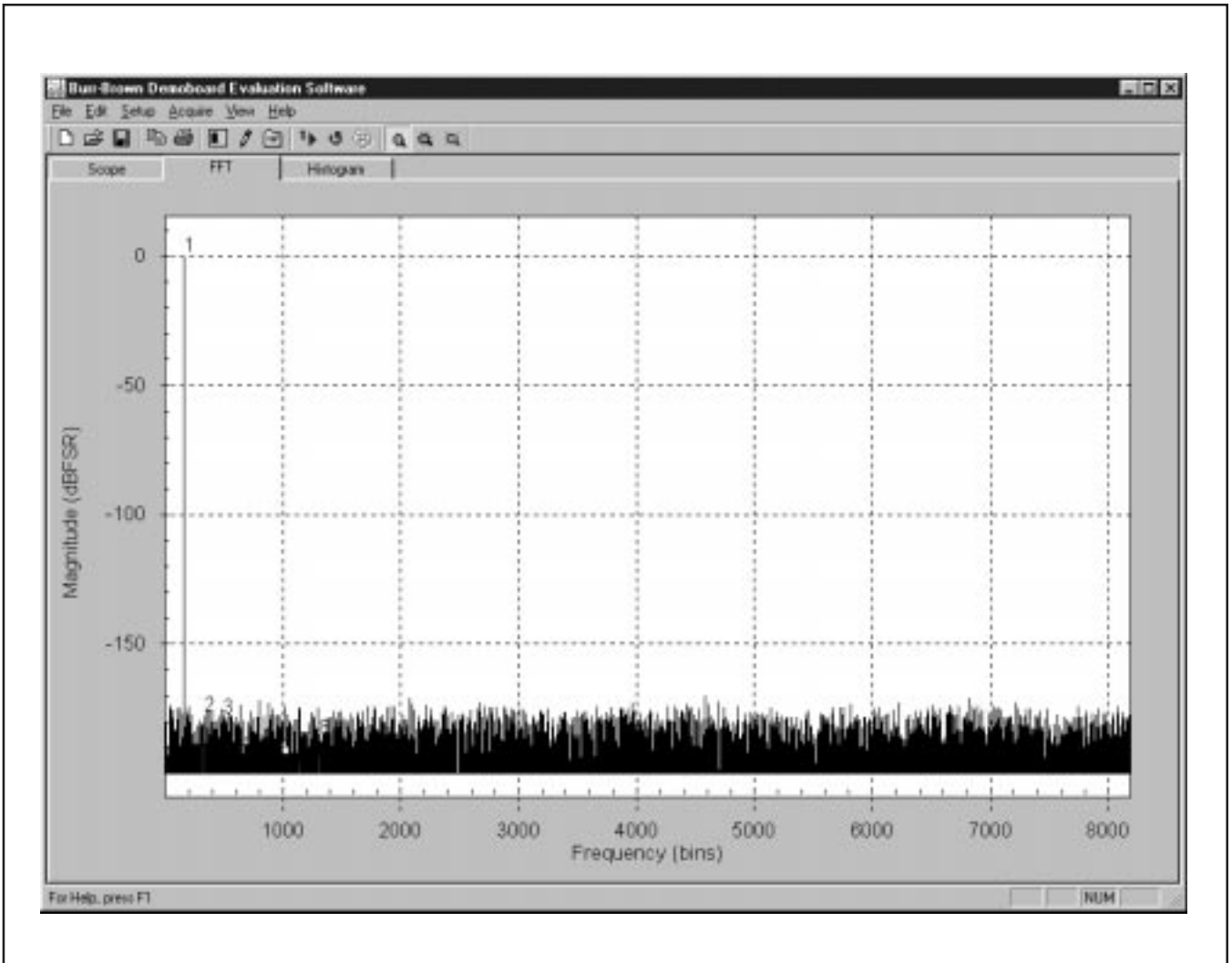

FIGURE 2. FFT Analysis Results for Synthetic Data.

The information provided herein is believed to be reliable; however, BURR-BROWN assumes no responsibility for inaccuracies or omissions. BURR-BROWN assumes no responsibility for the use of this information, and all use of such information shall be entirely at the user's own risk. Prices and specifications are subject to change without notice. No patent rights or licenses to any of the circuits described herein are implied or granted to any third party. BURR-BROWN does not authorize or warrant any BURR-BROWN product for use in life support devices and/or systems.

IMPORTANT NOTICE

Texas Instruments and its subsidiaries (TI) reserve the right to make changes to their products or to discontinue any product or service without notice, and advise customers to obtain the latest version of relevant information to verify, before placing orders, that information being relied on is current and complete. All products are sold subject to the terms and conditions of sale supplied at the time of order acknowledgment, including those pertaining to warranty, patent infringement, and limitation of liability.

TI warrants performance of its products to the specifications applicable at the time of sale in accordance with TI's standard warranty. Testing and other quality control techniques are utilized to the extent TI deems necessary to support this warranty. Specific testing of all parameters of each device is not necessarily performed, except those mandated by government requirements.

Customers are responsible for their applications using TI components.

In order to minimize risks associated with the customer's applications, adequate design and operating safeguards must be provided by the customer to minimize inherent or procedural hazards.

TI assumes no liability for applications assistance or customer product design. TI does not warrant or represent that any license, either express or implied, is granted under any patent right, copyright, mask work right, or other intellectual property right of TI covering or relating to any combination, machine, or process in which such products or services might be or are used. TI's publication of information regarding any third party's products or services does not constitute TI's approval, license, warranty or endorsement thereof.

Reproduction of information in TI data books or data sheets is permissible only if reproduction is without alteration and is accompanied by all associated warranties, conditions, limitations and notices. Representation or reproduction of this information with alteration voids all warranties provided for an associated TI product or service, is an unfair and deceptive business practice, and TI is not responsible nor liable for any such use.

Resale of TI's products or services with statements different from or beyond the parameters stated by TI for that product or service voids all express and any implied warranties for the associated TI product or service, is an unfair and deceptive business practice, and TI is not responsible nor liable for any such use.

Also see: [Standard Terms and Conditions of Sale for Semiconductor Products](http://www.ti.com/sc/docs/stdterms.htm). www.ti.com/sc/docs/stdterms.htm

Mailing Address:

Texas Instruments
Post Office Box 655303
Dallas, Texas 75265