

- NOTES:
1. ASSURE ASSEMBLY CAPABILITY BY MATCHING WITH MATING PART
 2. DIMENSIONS IN [] ARE IN MILLIMETERS

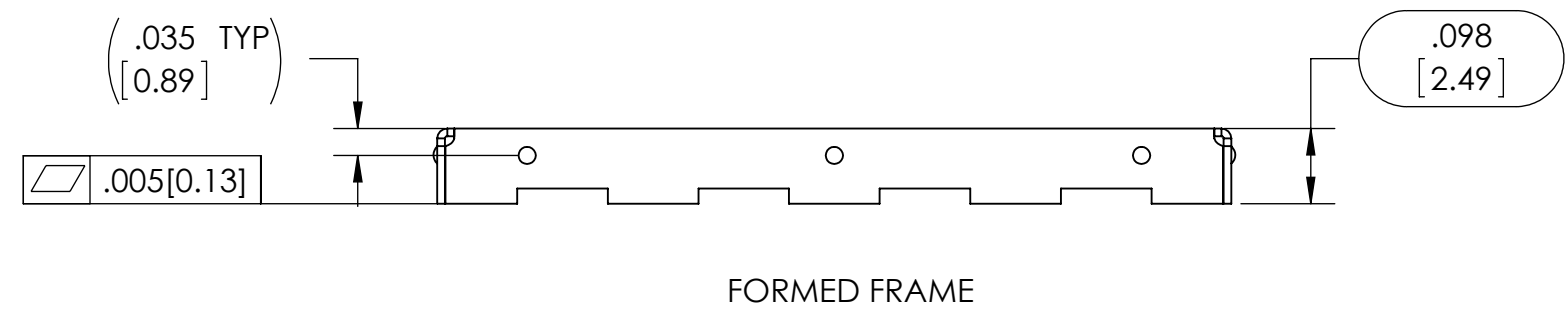

FORMED FRAME

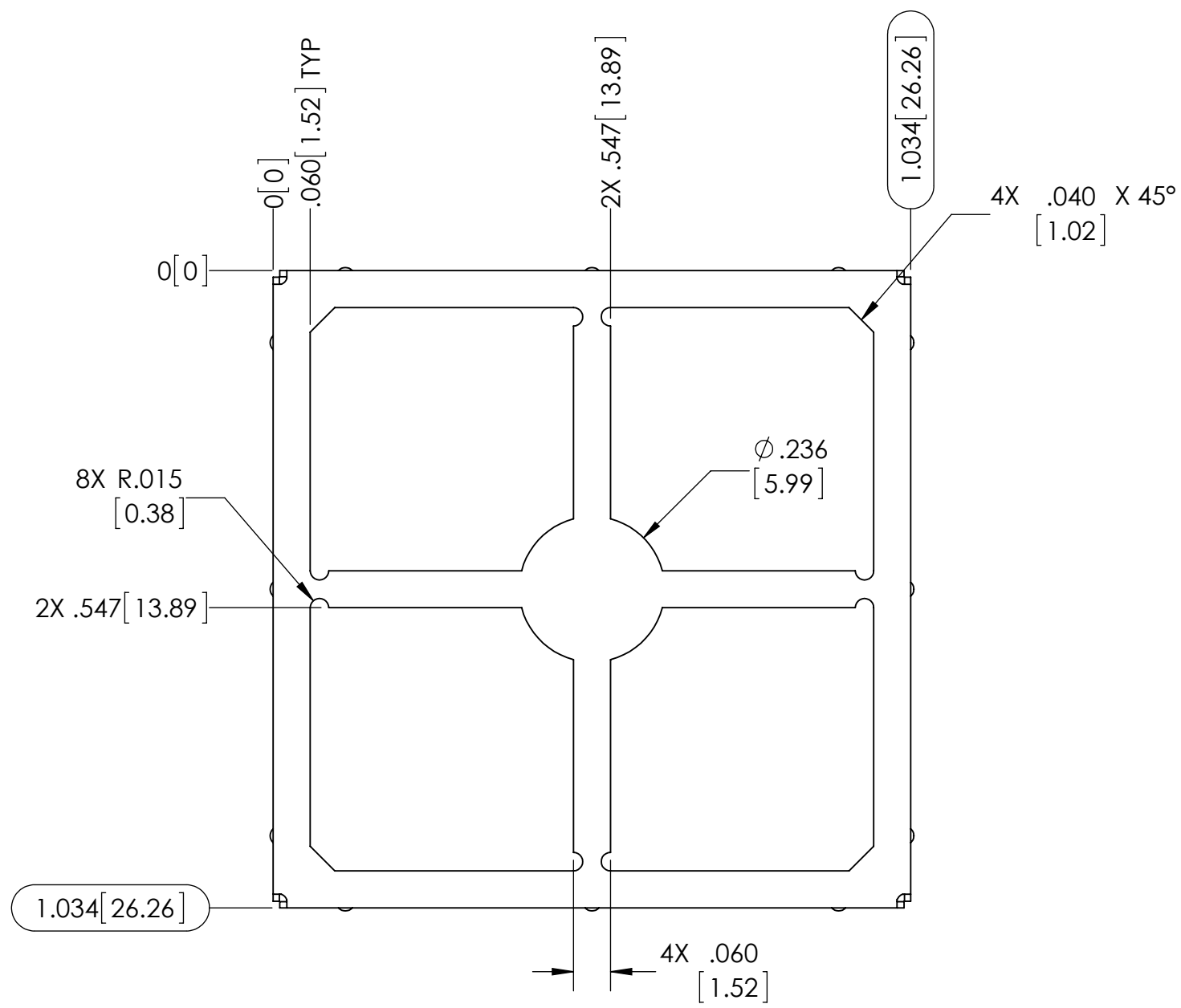
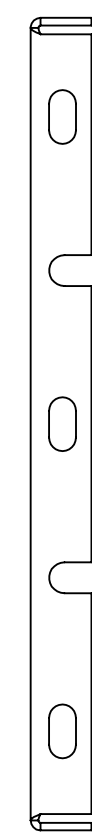
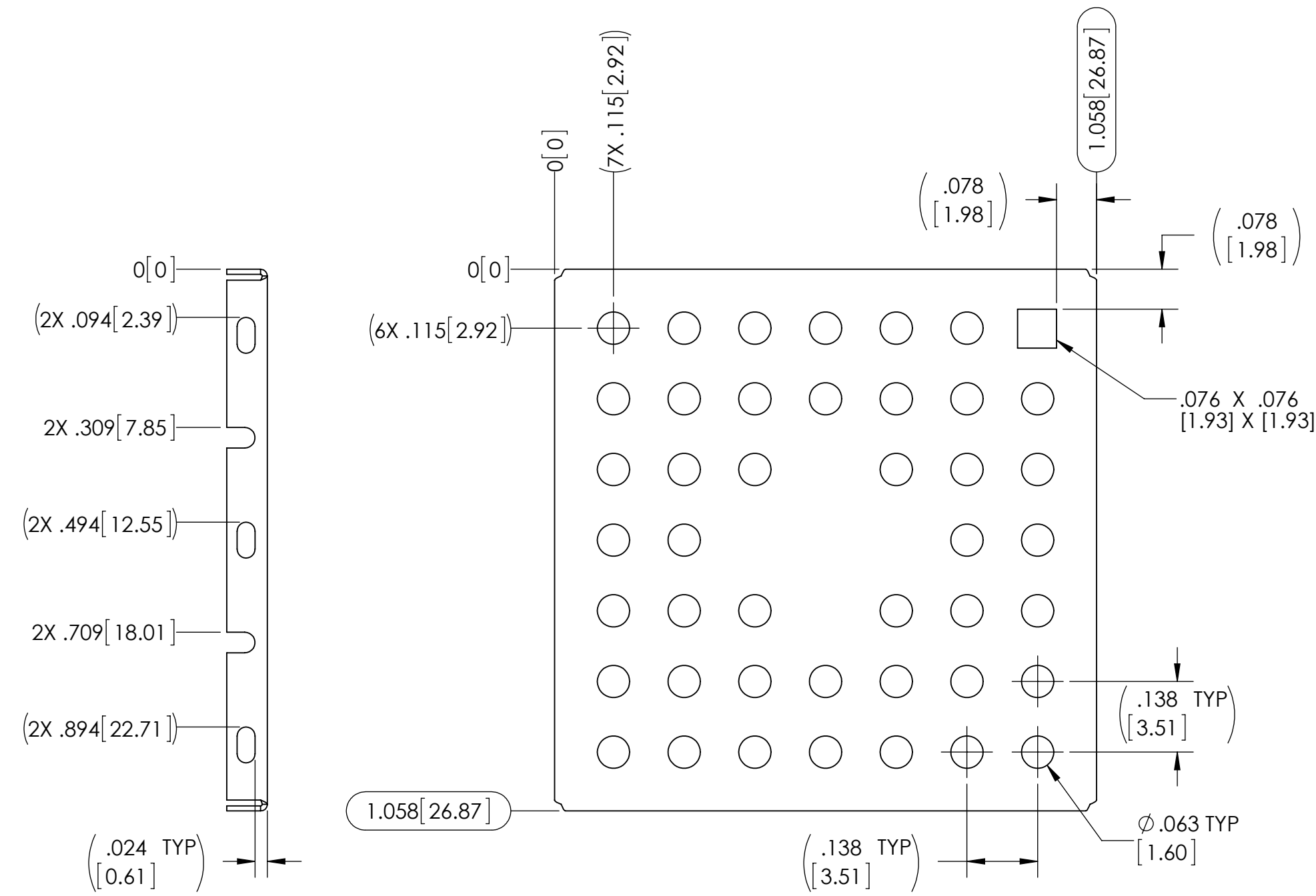
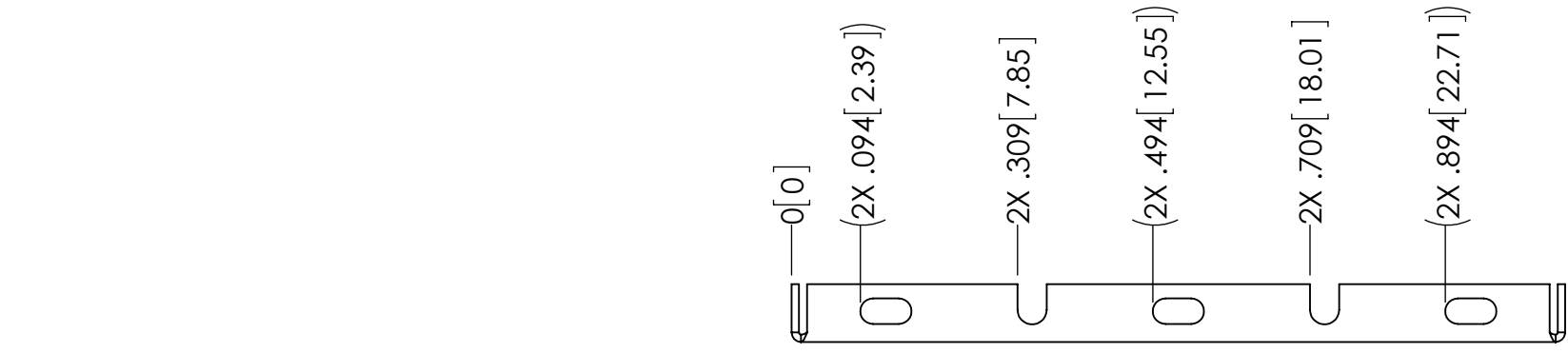
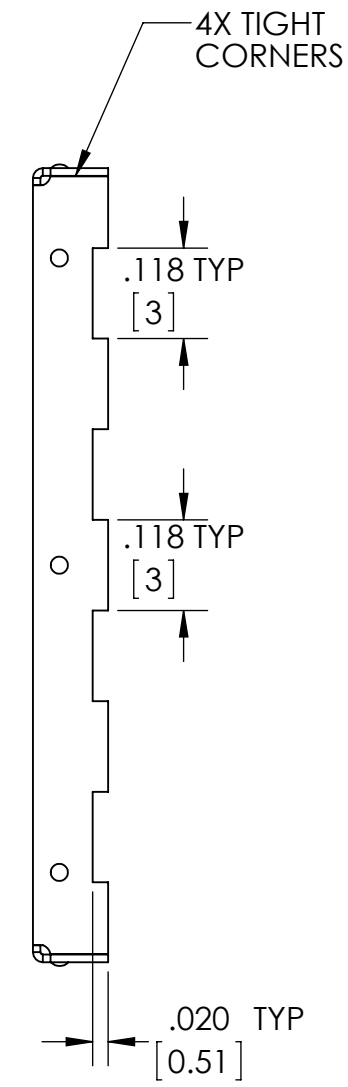

4X TIGHT CORNERS

.020 TYP [0.51]

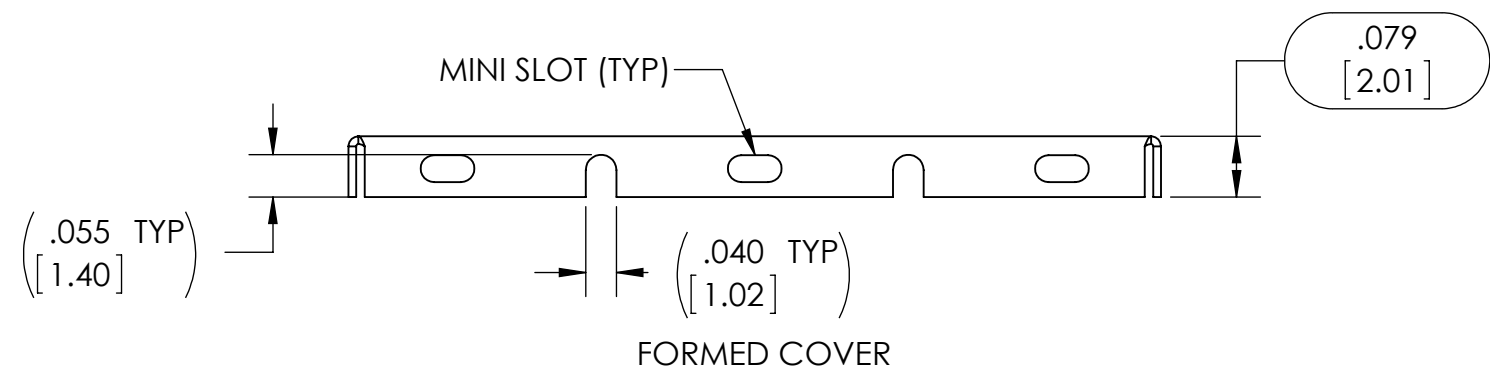

FORMED COVER

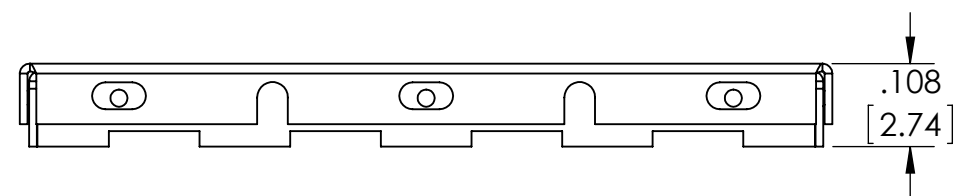

ASSEMBLY

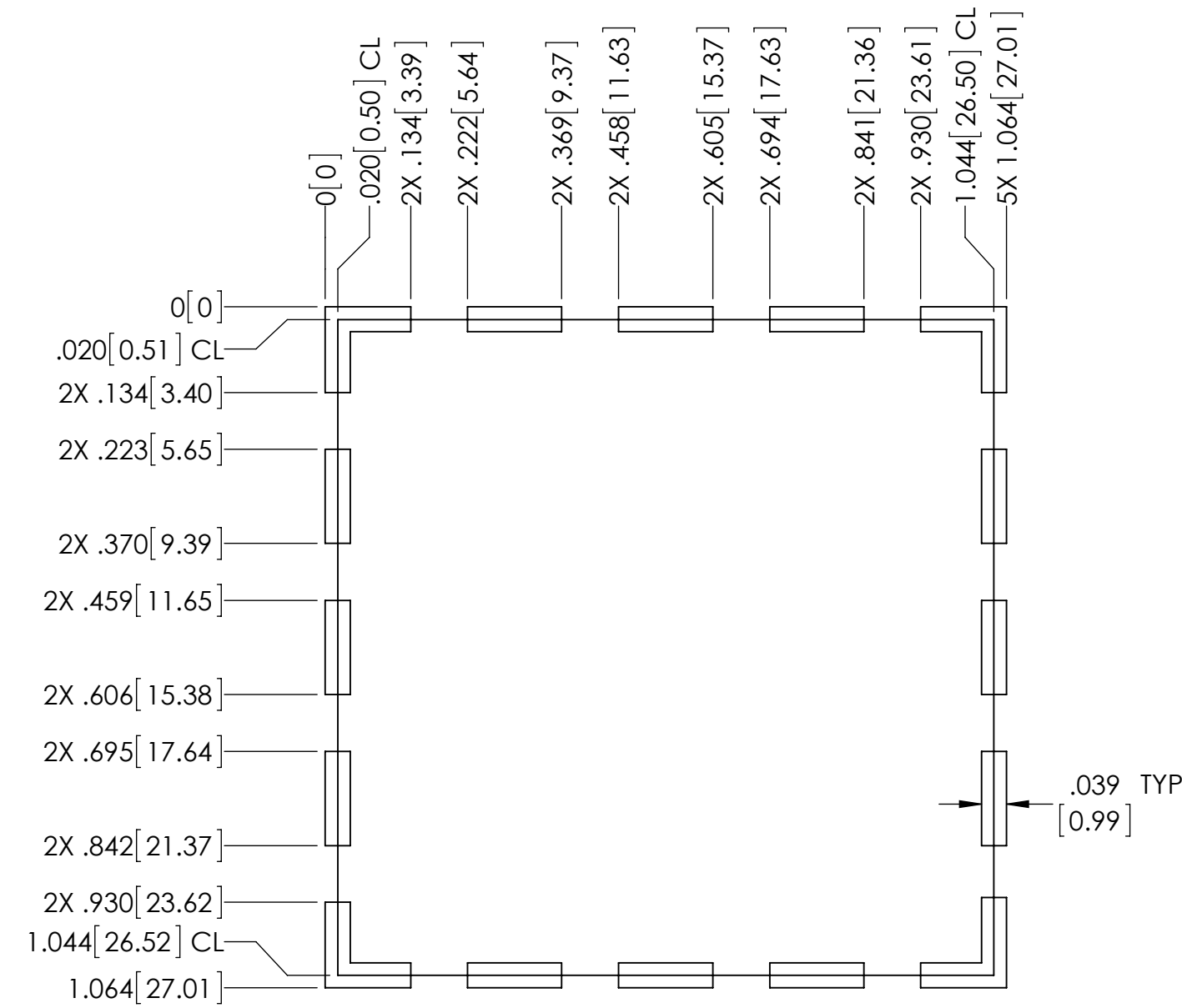
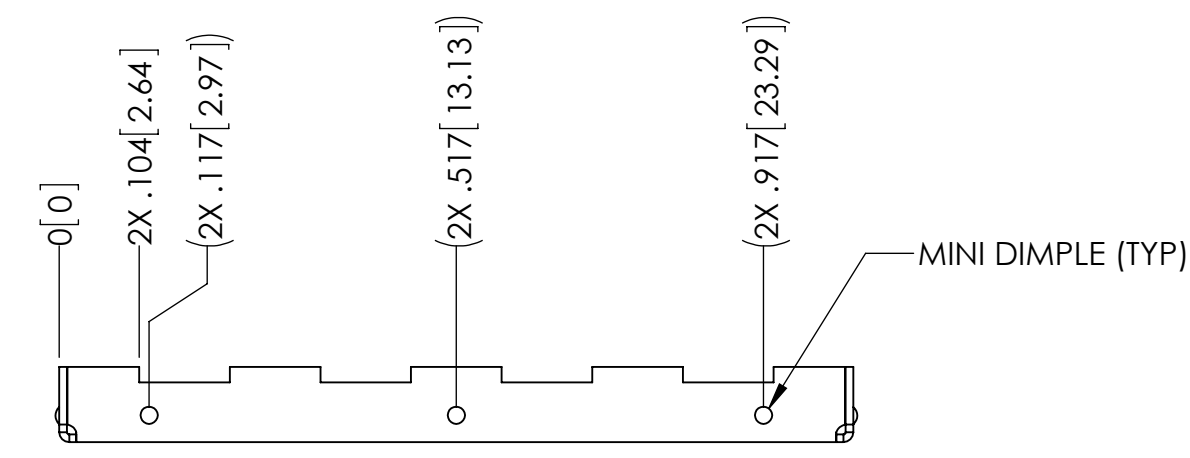

TRACE PATTERN

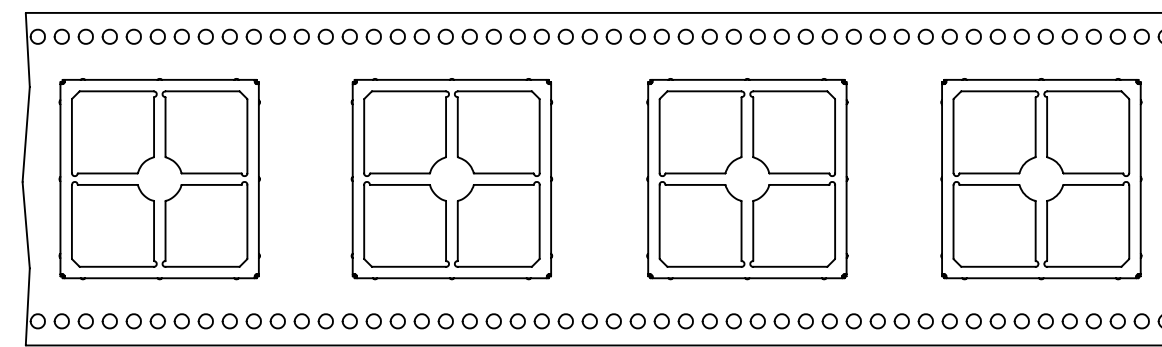
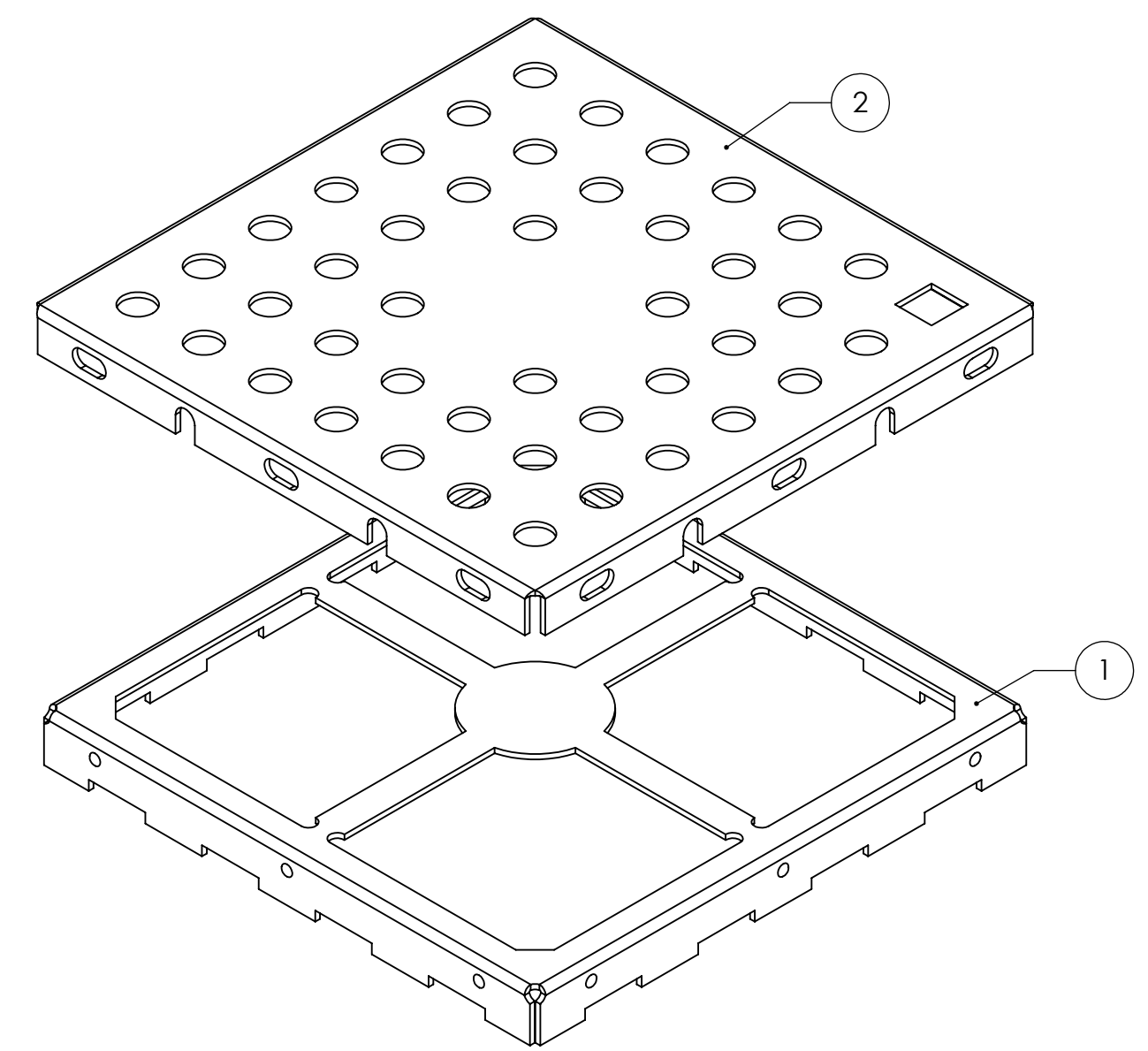

CARRIER TAPE

CARRIER TAPE SPECIFICATIONS						
PART NUMBER	DESCRIPTION	OVERALL DIMENSIONS	OVERALL HEIGHT	CARRIER TAPE WIDTH	CARRIER TAPE PITCH	PARTS PER REEL
SMS-254-F	FRAME	1.034 X 1.034 (26.26 X 26.26)	.098 (2.49)	44 mm	32 mm	300 Δ
SMS-254-C	COVER	1.058 X 1.058 (26.87 X 26.87)	.079 (2.01)	N/A	N/A	BULK PACK

TEM NO.	PART NUMBER	DESCRIPTION	QTY.
1	SMS-254 F	FRAME	1
2	SMS-254 C	COVER	1

UNLESS OTHERWISE SPECIFIED:
 - ALL DIMENSIONS ARE IN INCHES
 - PART SHALL BE FREE OF BURRS AND SHARP EDGES
 - ALL DIMENSIONS SHOWN APPLY BEFORE PLATING AND COATINGS
 - ROHS COMPLIANT PER EU DIRECTIVE 2011/65/EU
 - POI = POINT OF INTERSECTION

THIRD ANGLE PROJECTION

LEADER TECH
 a HEICO company
 The Leading Edge in PAM Housing Technology

TITLE: SLOT LOK LOW PROFILE

DRAWN BY: NA 2014-03-11 APPROVED BY: TS 2013-03-11

FRISH: BRIGHT MATERIAL: .010[0.25] - PRE TIN STEEL

SIZE: D DWG. NO.: SMS-254 SHEET: 1 OF 1

SCALE: 4:1 CAGE CODE: 4J674

THIS DOCUMENT CONTAINS PROPRIETARY INFORMATION OWNED BY LEADERTECH OR DEVELOPED AT ITS OWN PRIVATE EXPENSE AND MAY NOT BE USED, DUPLICATED OR DISCLOSED IN WHOLE OR IN PART FOR ANY PURPOSE INCLUDING DESIGN, MANUFACTURE OR PROCUREMENT WITHOUT THE WRITTEN PERMISSION OF LEADERTECH. LEADERTECH DOES NOT GUARANTEE OR WARRANT THE PERFORMANCE CHARACTERISTICS.