

DO NOT SCALE FROM THIS PRINT

DESIGNED & DIMENSIONED IN MILLIMETERS [INCHES]

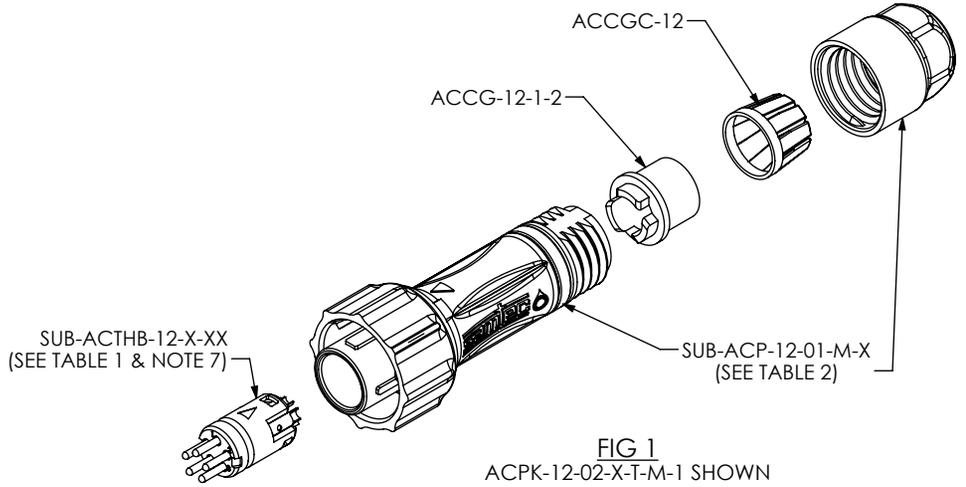

FIG 1  
ACPK-12-02-X-T-M-1 SHOWN

**ACPK-12-XX-X-X-M-X**

PLUG KIT  
SIZE  
LEAD STYLE  
-01: 4 POS (1.0 TERM/SKT), 20 - 24 AWG  
-02: 5 POS (1.0 TERM/SKT), 20 - 24 AWG  
-03: 6 POS (0.5 TERM/SKT), 26 - 30 AWG  
-04: 8 POS (0.5 TERM/SKT), 26 - 30 AWG  
-05: 6 POS COMBO (2x1.0 TERM/SKT), 20 - 24 AWG (4x0.5 TERM/SKT), 26 - 30 AWG  
PLATING  
-G: 10µ" GOLD ON CONTACT  
-H: 30µ" GOLD ON CONTACT

KEYING FEATURE (SEE NOTE 3, SEE SHT 2)  
-1: ORANGE  
-2: GREEN  
-3: BLUE  
-4: YELLOW

STYLE  
-M: METAL

GENDER  
-T: TERMINAL  
-S: SOCKET

TABLE 2	
KEYING FEATURE	SUB-ACP-12-XX-M-X
-1	SUB-ACP-12-01-M-1
-2	SUB-ACP-12-01-M-2
-3	SUB-ACP-12-01-M-3
-4	SUB-ACP-12-01-M-4

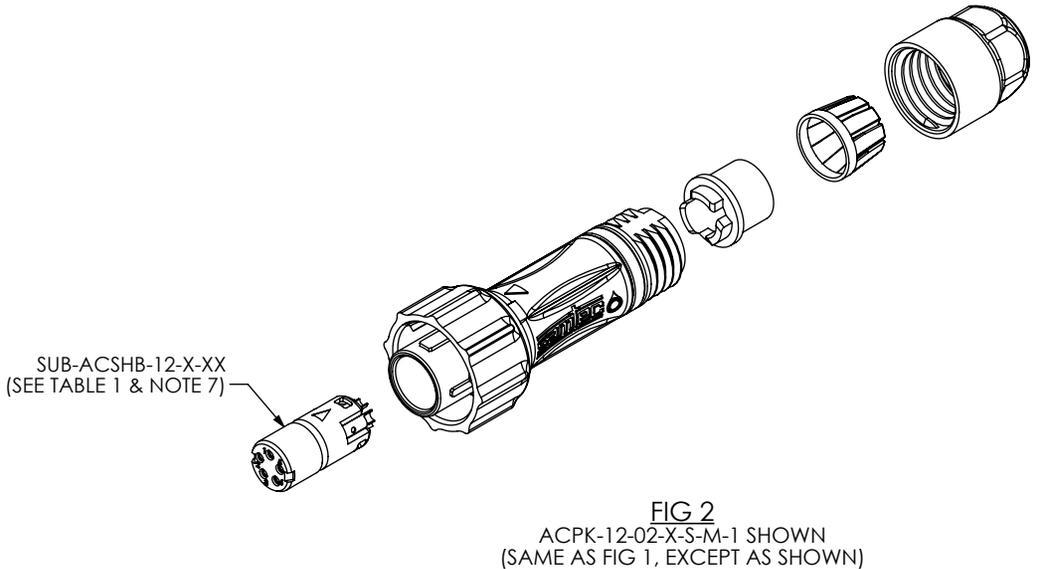

FIG 2  
ACPK-12-02-X-S-M-1 SHOWN (SAME AS FIG 1, EXCEPT AS SHOWN)

TABLE 1			
LEAD STYLE	GENDER	PLATING	
		-G	-H
-01	-T	SUB-ACTHB-12-G-01	SUB-ACTHB-12-H-01
-02	-T	SUB-ACTHB-12-G-02	SUB-ACTHB-12-H-02
-03	-T	SUB-ACTHB-12-G-03	SUB-ACTHB-12-H-03
-04	-T	SUB-ACTHB-12-G-04	SUB-ACTHB-12-H-04
-05	-T	SUB-ACTHB-12-G-05	SUB-ACTHB-12-H-05
-01	-S	SUB-ACSHB-12-G-01	SUB-ACSHB-12-H-01
-02	-S	SUB-ACSHB-12-G-02	SUB-ACSHB-12-H-02
-03	-S	SUB-ACSHB-12-G-03	SUB-ACSHB-12-H-03
-04	-S	SUB-ACSHB-12-G-04	SUB-ACSHB-12-H-04
-05	-S	SUB-ACSHB-12-G-05	SUB-ACSHB-12-H-05

NOTES:

1. Ⓢ REPRESENTS A CRITICAL DIMENSION.
2. KIT COMPONENTS TO BE PACKAGED IN BAGS PER PACKAGING STANDARD CO-RF-WI-3001-M.
3. KEYING FEATURE DETERMINES COLOR OF KEY RING AND DUSTCAP LANYARD IF APPLICABLE.
4. REFER TO DCA-ACP-12-M-X PRINT FOR DUST CAP.
5. CABLE DIAMETER SPECIFICATION: 5.21 [.205].
6. TORQUE SPECIFICATION FOR CABLE NUT: 1.1Nm [10.00 IN-LB] - 1.7Nm [15.00 IN-LB].
7. RECOMMENDED INSERTION TOOL: CAT-12-M.
8. NOTE DELETED.

UNLESS OTHERWISE SPECIFIED, DIMENSIONS ARE IN MILLIMETERS. TOLERANCES ARE:  
DECIMALS ANGLES  
X.X: ±0.3 [.01] 2°  
X.XX: ±0.13 [.005]  
X.XXX: ±0.051 [.0020]

**PROPRIETARY NOTE**  
THIS DOCUMENT CONTAINS CONFIDENTIAL AND PROPRIETARY INFORMATION AND ALL DESIGN, MANUFACTURING, REPRODUCTION, USE, PATENT RIGHTS AND SALES RIGHTS ARE EXPRESSLY RESERVED BY SAMTEC, INC. THIS DOCUMENT SHALL NOT BE DISCLOSED, IN WHOLE OR PART, TO ANY UNAUTHORIZED PERSON OR ENTITY NOR REPRODUCED, TRANSFERRED OR INCORPORATED IN ANY OTHER PROJECT IN ANY MANNER WITHOUT THE EXPRESS WRITTEN CONSENT OF SAMTEC, INC.

**samtec**  
520 PARK EAST BLVD, NEW ALBANY, IN 47150  
PHONE: 812-944-6733 FAX: 812-948-5047  
e-Mail: info@SAMTEC.com code 53322

**MATERIAL:** DO NOT SCALE DRAWING SHEET SCALE: 1:1  
SHELLS/LOCKING SLEEVE/NUT: ZAMAK 3  
RETAINING RING: CARBON STEEL  
COLOR RING: SILICONE  
INSULATOR: PBT, COLOR: BLACK  
GROMMET CAGE: NYLON, COLOR: BLACK  
TERMINALS: BRASS  
CONTACTS: BRASS/BeCu  
GROMMET: NITRILE

DESCRIPTION:  
ACCLIMATE CIRC. FIELD TERM.  
DWG. NO.  
**ACPK-12-XX-X-X-M-X**  
BY: D.SCHMELZ 01/17/2011 SHEET 1 OF 2

-I END OPTIONS

-01: 4 POS  
Ø 1.0 TERMINALS

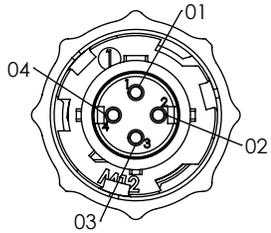

-02: 5 POS  
Ø 1.0 TERMINALS

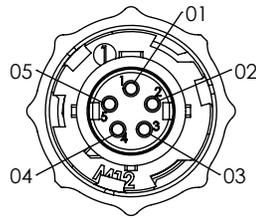

-03: 6 POS  
Ø 0.5 TERMINALS

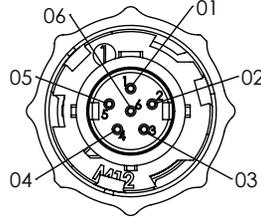

-04: 8 POS  
Ø 0.5 TERMINALS

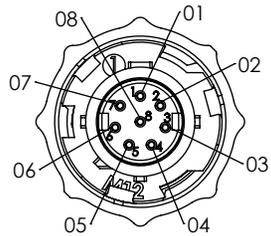

-05: 6 POS COMBO  
2x Ø 1.0 TERMINALS  
4x Ø 0.5 TERMINALS

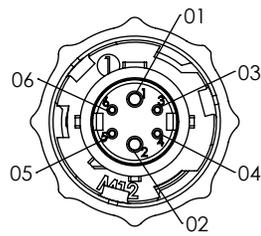

-S END OPTIONS

-01: 4 POS  
Ø 1.0 SOCKETS

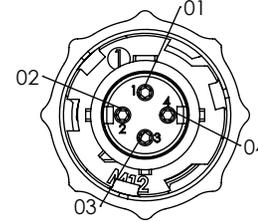

-02: 5 POS  
Ø 1.0 SOCKETS

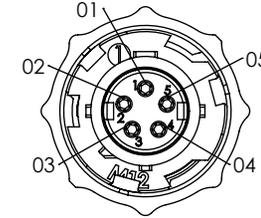

-03: 6 POS  
Ø 0.5 SOCKETS

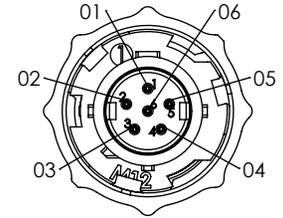

-04: 8 POS  
Ø 0.5 SOCKETS

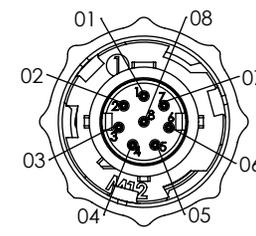

-05: 6 POS CPMBO  
2x Ø 1.0 SOCKETS  
4x Ø 0.5 SOCKETS

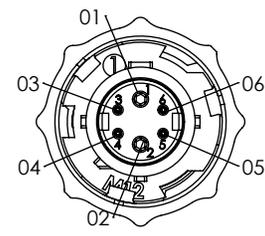

-1  
ORANGE KEY RING

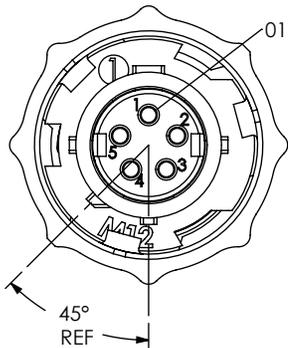

-2  
GREEN KEY RING

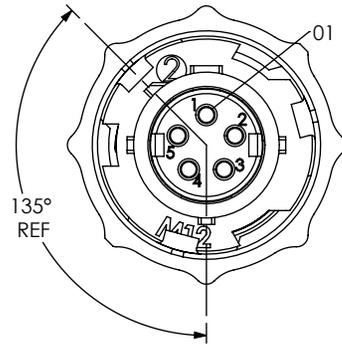

KEYING FEATURE  
(SEE NOTE 3)

-3  
BLUE KEY RING

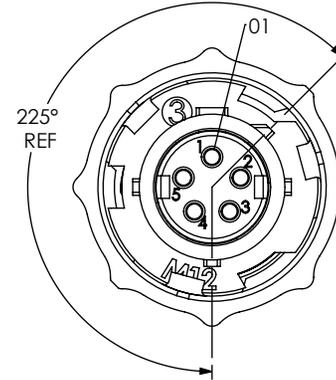

-4  
YELLOW KEY RING

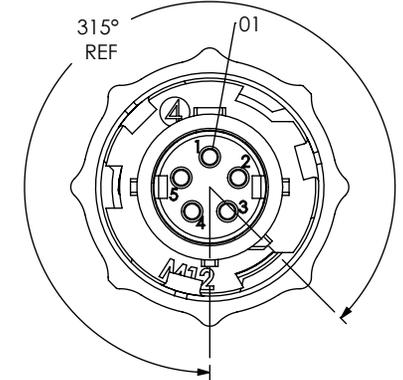

SCALE: 2:1

**PROPRIETARY NOTE**  
THIS DOCUMENT CONTAINS CONFIDENTIAL AND PROPRIETARY INFORMATION AND ALL DESIGN, MANUFACTURING, REPRODUCTION, USE, PATENT RIGHTS AND SALES RIGHTS ARE EXPRESSLY RESERVED BY SAMTEC, INC. THIS DOCUMENT SHALL NOT BE DISCLOSED, IN WHOLE OR PART, TO ANY UNAUTHORIZED PERSON OR ENTITY NOR REPRODUCED, TRANSFERRED OR INCORPORATED IN ANY OTHER PROJECT IN ANY MANNER WITHOUT THE EXPRESS WRITTEN CONSENT OF SAMTEC, INC.

DO NOT SCALE DRAWING

SHEET SCALE: 3:2

**samtec**

520 PARK EAST BLVD, NEW ALBANY, IN 47150  
PHONE: 812-944-6733 FAX: 812-948-5047  
e-Mail info@SAMTEC.com code 55322

DESCRIPTION: ACCLIMATE CIRC. FIELD TERM.

DWG. NO. ACPK-12-XX-X-X-M-X

BY: D.SCHMELZ 01/17/2011 | SHEET 2 OF 2