

RELEASED FOR PUBLICATION
 FREI FUER VEROFFENTLICHUNG
 VERTRAULICHE UNVEROFFENTLICHTE ZEICHNUNG.
 BY AMP INCORPORATED. ALL RIGHTS RESERVED.
 COPYRIGHT 1996
 ALLE RECHTE VORBEHALTEN.

| | | | | | | | | |
|----------------------------|-----------|-----------|--------------------------|----------------------|-----------------------------|------------|-------|---------|
| MATED WITH: PASSEND ZU: | LOC AI | DIST - | REVISIONS AENDERUNGEN | | | DATE | DWN | APVD |
| - | AI | - | P | LTR | DESCRIPTION BESCHREIBUNG | 07.06.2001 | TILLE | KRAEMER |
| PROJEKT NR.: E96-52 584 | | | B1 | KODIERSTEG GEAENDERT | | | | |

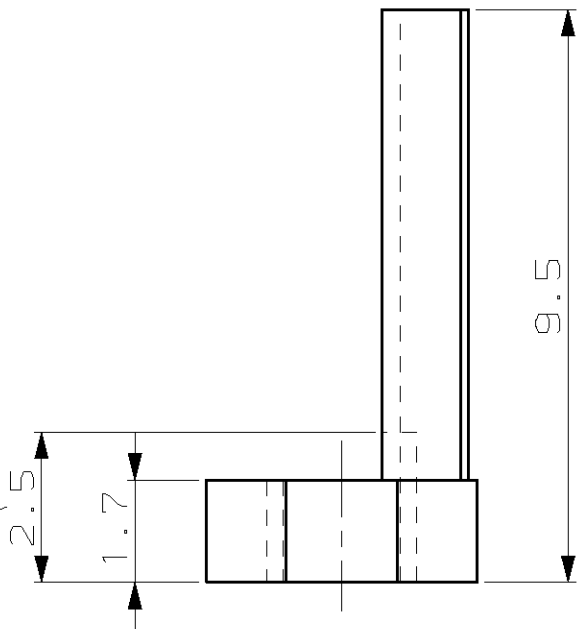

NUTZBARE GEWINDELÄNGE

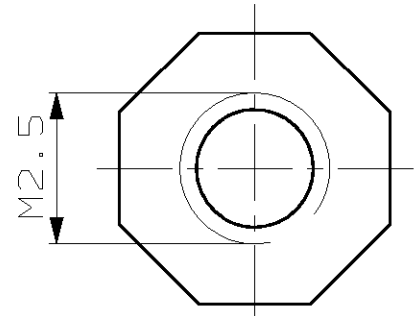
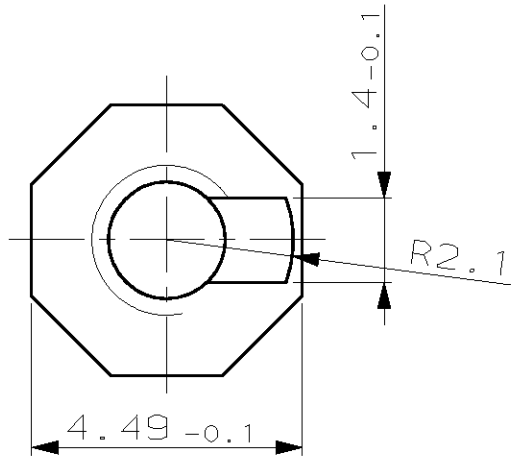

| | | | | | |
|---------------------|----------------|----------------------|------------------|---------------------------------------|---|
| - | 966 963-1 | NICHTROSTENDER STAHL | BLANK | POSITION MARK POSITIONIERERKENNUNG | 1 |
| CUSTOMER PART NO | AMP PART NO | MATERIAL | SURFACE COLOR | DESCRIPTION | |

| | | | | | | | | | | | | |
|---|------------------------------|-----------|--|-----------|---------------------------------------|---------------------------|-------|---|----|---|-----|----|
| DIMENSIONS: DIMENSIONEN: mm TOLERANCES UNLESS OTHERWISE SPECIFIED: ALLGEMEINTOLERANZEN n. ISO 8015 n. ISO 2768 - mH - E n. DIN 16901 - 140 0 PLC ±0.1 1 PLC ±0.1 2 PLC ±0.1 3 PLC ± ANGLES/WINKEL ±- | DWN W. TILLE | 17-JUN-96 | MATERIAL | - | FINISH OBERFLAECHE/FARBE | - | | | | | | |
| | CHK R. KRÄMER | 17-JUN-96 | AMP tyco Electronics AMP GmbH D - 64625 Bensheim | | | | | | | | | |
| | APVD G. FELDMEIER | 17-JUN-96 | | | | | | | | | | |
| | PRODUCT SPEC PRODUKTSPEZ. | - | | NAME | POSITION MARK POSITIONIERERKENNUNG | | | | | | | |
| APPLICATION SPEC VERARBEITUNGSSPEZ. | - | | SIZE | CAGE CODE | DRAWING NO ZEICHNUNGS-NR. | RESTRICTED TO NUR FUER | | | | | | |
| WEIGHT GEWICHT | - | | A4 | 00779 | C-966963 | - | | | | | | |
| CUSTOMER DRAWING | | | /KUNDENZEICHNUNG | | MASSSTAB | 8:1 | BLATT | 1 | OF | 1 | REV | B1 |