

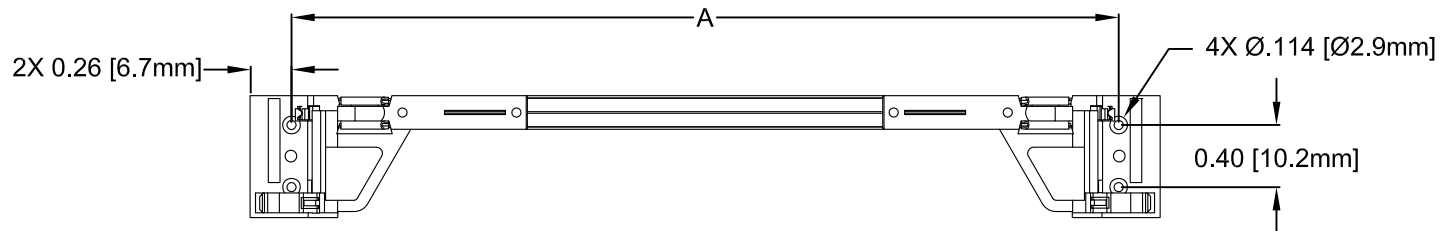

ITEM	Q'TY	PART NUMBER	PART DESCRIPTION
1	1	CPCI-RXXX	Card Guide, Pre-Assembled with Aluminum Body
2	X	CPCI-ESD1	CPCI ESD Clips, PCB Grounding, SEE SHEET 2 TABLE 1
3	X	CPCI-ESD2	CPCI ESD Clips, Extractor Grounding, SEE SHEET 2 TABLE 1

REV.	DESCRIPTION	DATE	APPROVED
B	Engineering Release.	11/20/14	J. C.

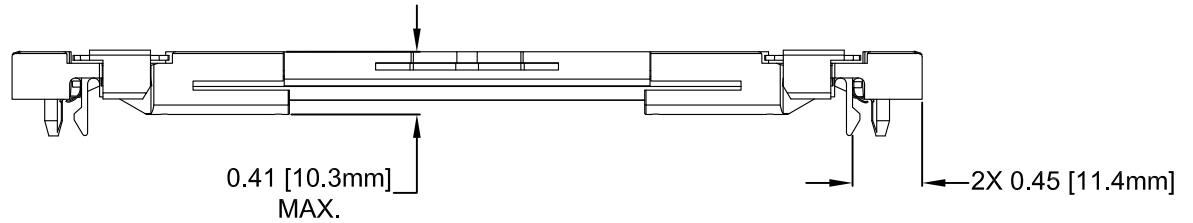
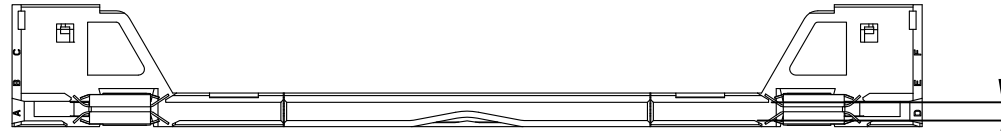
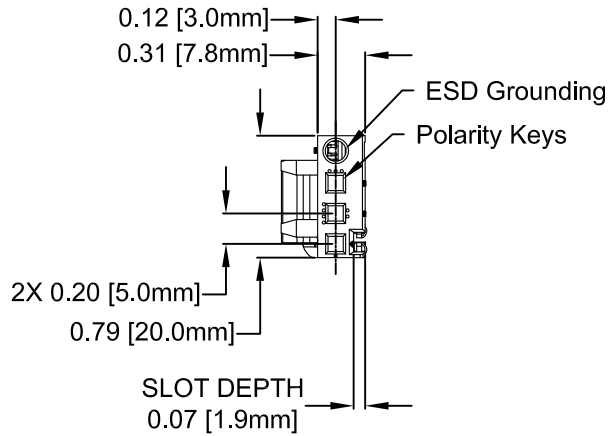

2. MATERIAL: POLYCARBONATE, GLASS FILLED 20% & ALUMINUM BODY
1. GENERAL SPECIFICATIONS: BIVAR MOLDED COMPONENT SPECIFICATION BV00-E101.

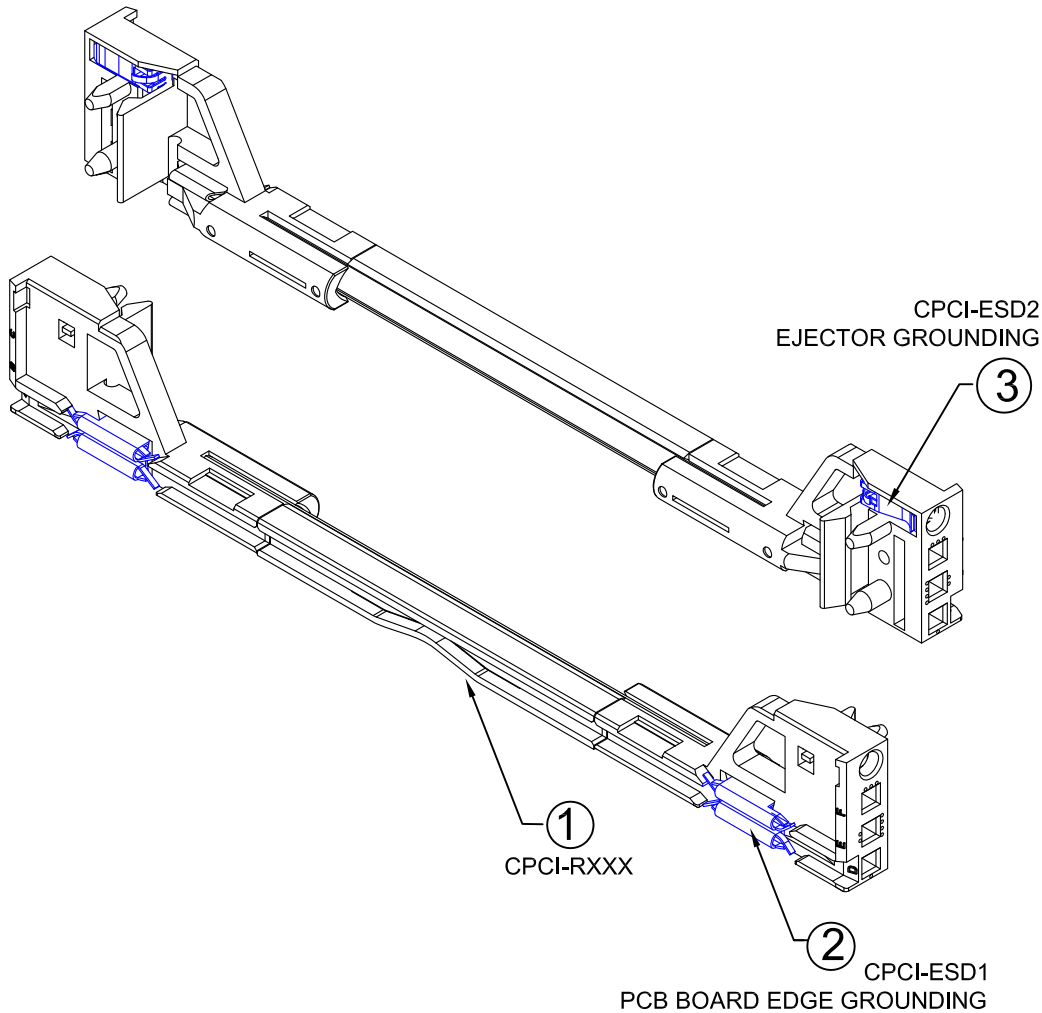

STANDARD TOLERANCE (UNLESS OTHERWISE SPECIFIED)		 BIVAR [®] 4 THOMAS, IRVINE, CA. 92618 TEL: (949) 951-8808 FAX: (949) 951-3974
DECIMALS	ANGULAR	
.X ±.1	X° ± 1°	
.XX ±.01		TITLE: CPCI PLASTIC RETENTION GUIDE WITH ESD CLIPS REVISION: B
.XXX ±.005		
DESIGNED: Alex Wright	DATE: 07/07/14	PART NO: CPCI-RXXX-ESDXX
CHECKED: Brian Oliver	DATE: 07/07/14	CAGE CODE : 32559 SHEET # 1 OF 2
CAD GENERATED DOCUMENT, DO NOT MEASURE DRAWING.		

REV.	DESCRIPTION	DATE	APPROVED
	SEE SHEET #1		



ASSEMBLY PART NUMBERS	A in [mm]	ITEM	QTY
CPCI-R160-ESD1	5.34 [135.7]	2	2
CPCI-R160-ESD2	5.34 [135.7]	3	2
CPCI-R160-ESD12	5.34 [135.7]	2 3	2 2
CPCI-R220-ESD1	7.69 [195.3]	2	2
CPCI-R220-ESD2	7.69 [195.3]	3	2
CPCI-R220-ESD12	7.69 [195.3]	2 3	2 2
CPCI-R280-ESD1	10.07 [255.9]	2	2
CPCI-R280-ESD2	10.07 [255.9]	3	2
CPCI-R280-ESD12	10.07 [255.9]	2 3	2 2
CPCI-R340-ESD1	12.44 [316.0]	2	2
CPCI-R340-ESD2	12.44 [316.0]	3	2
CPCI-R340-ESD12	12.44 [316.0]	2 3	2 2

NOTE: ESD CLIPS COME PRE-ASSEMBLED

STANDARD TOLERANCE (UNLESS OTHERWISE SPECIFIED)		 BIVAR [®] 4 THOMAS, IRVINE, CA. 92618 TEL: (949) 951-8808 FAX: (949) 951-3974	
DECIMALS	ANGULAR		
.X ±.1	X° ± 1°	 TITLE: CPCI PLASTIC RETENTION GUIDES WITH ESD CLIPS	
.XX ±.01			
.XXX ±.005			
DESIGNED: Alex Wright	DATE: 07/07/14	PART NO: CPCI-RXXX-ESDXX	REVISION: B
CHECKED: Brian Oliver	DATE: 07/07/14	CAGE CODE : 32559	SHEET # 2 OF 2
CAD GENERATED DOCUMENT, DO NOT MEASURE DRAWING.			