

General Description

The MAX1044 and ICL7660 are monolithic, CMOS switched-capacitor voltage converters that invert, double, divide, or multiply a positive input voltage. They are pin compatible with the industry-standard ICL7660 and LTC1044. Operation is guaranteed from 1.5V to 10V with no external diode over the full temperature range. They deliver 10mA with a 0.5V output drop. The MAX1044 has a BOOST pin that raises the oscillator frequency above the audio band and reduces external capacitor size requirements.

The MAX1044/ICL7660 combine low quiescent current and high efficiency. Oscillator control circuitry and four power MOSFET switches are included on-chip. Applications include generating a -5V supply from a +5V logic supply to power analog circuitry. For applications requiring more power, the MAX660 delivers up to 100mA with a voltage drop of less than 0.65V.

Applications

- -5V Supply from +5V Logic Supply
- Personal Communications Equipment
- Portable Telephones
- Op-Amp Power Supplies
- EIA/TIA-232E and EIA/TIA-562 Power Supplies
- Data-Acquisition Systems
- Hand-Held Instruments
- Panel Meters

Typical Operating Circuit

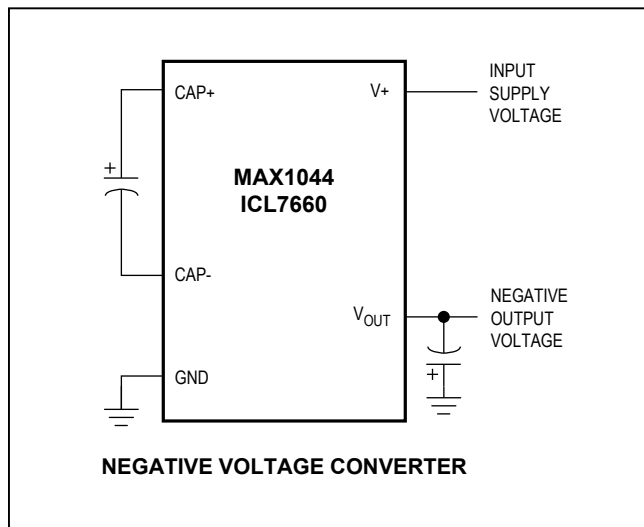

Features

- Miniature μ MAX Package
- 1.5V to 10.0V Operating Supply Voltage Range
- 98% Typical Power-Conversion Efficiency
- Invert, Double, Divide, or Multiply Input Voltages
- BOOST Pin Increases Switching Frequencies (MAX1044)
- No-Load Supply Current: 200 μ A Max at 5V
- No External Diode Required for Higher-Voltage Operation

Ordering Information appears at end of data sheet.

Pin Configurations

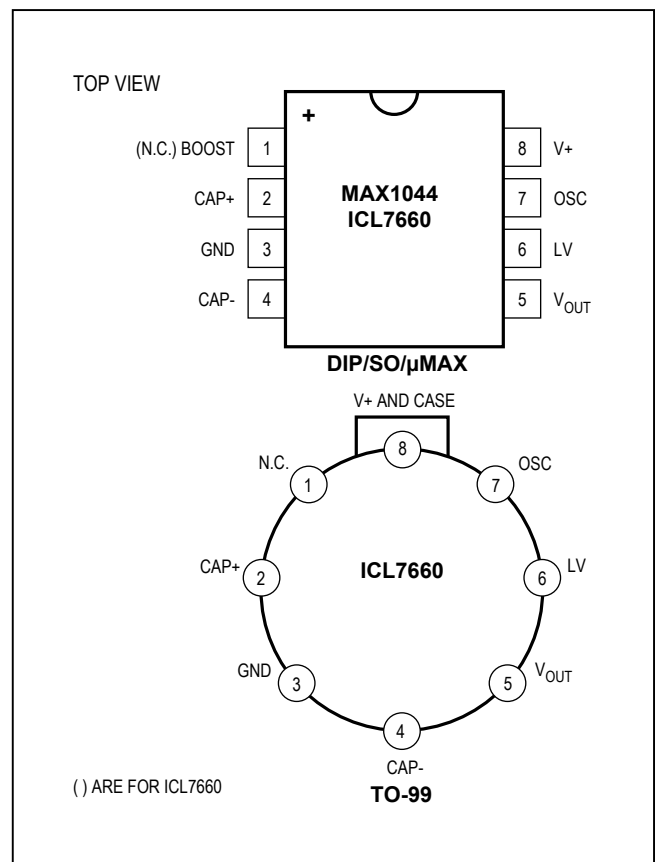

Absolute Maximum Ratings

Supply Voltage (V+ to GND, or GND to V _{OUT}).....	10.5V	CERDIP (derate 8.00mW/°C above +70°C).....	640mW
Input Voltage on Pins 1, 6, and 7.....	-0.3V ≤ V _{IN} ≤ (V+ + 0.3V)	TO-99 (derate 6.67mW/°C above +70°C).....	533mW
LV Input Current	20µA	Operating Temperature Ranges	
Output Short-Circuit Duration (V+ ≤ 5.5V)	Continuous	MAX1044C__/ICL7660C__	0°C to +70°C
Continuous Power Dissipation (T _A = +70°C)		MAX1044E__/ICL7660E__	-40°C to +85°C
Plastic DIP (derate 9.09mW/°C above +70°C).....	727mW	MAX1044M__/ICL7660M__	-55°C to +125°C
SO (derate 5.88mW/°C above +70°C).....	471mW	Storage Temperature Range.....	-65°C to + 150°C
µMAX (derate 4.1mW/°C above +70°C).....	330mW	Lead Temperature (soldering, 10sec)	+300°C

Stresses beyond those listed under "Absolute Maximum Ratings" may cause permanent damage to the device. These are stress ratings only, and functional operation of the device at these or any other conditions beyond those indicated in the operational sections of the specifications is not implied. Exposure to absolute maximum rating conditions for extended periods may affect device reliability.

Electrical Characteristics

(Circuit of Figure 1, V+ = 5.0V, LV pin = 0V, BOOST pin = open, I_{LOAD} = 0mA, T_A = T_{MIN} to T_{MAX}, unless otherwise noted.)

PARAMETER	CONDITIONS	MAX1044			ICL7660			UNITS
		MIN	TYP	MAX	MIN	TYP	MAX	
Supply Current	R _L = ∞, pins 1 and 7 no connection, LV open	T _A = +25°C	30	200	80	175	µA	
		T _A = 0°C to +70°C		200		225		
		T _A = -40°C to +85°C		200		250		
		T _A = -55°C to +125°C		200		250		
	R _L = ∞, pins 1 and 7 = V+ = 3V		10					
Supply Voltage Range (Note 1)	R _L = 10kΩ, LV open				3.0	10.0	V	
	R _L = 10kΩ, LV to GND	1.5		10	1.5	3.5		
Output Resistance	I _L = 20mA, f _{OSC} = 5kHz, LV open	T _A = +25°C	65	100	55	100	Ω	
		T _A = 0°C to +70°C		130		120		
		T _A = -40°C to +85°C		130		140		
		T _A = -55°C to +125°C		150		150		
	f _{OSC} = 2.7kHz (ICL7660), f _{OSC} = 1kHz (MAX1044), V+ = 2V, I _L = 3mA, LV to GND	T _A = +25°C		325		250	Ω	
		T _A = 0°C to +70°C		325		300		
		T _A = -40°C to +85°C		325		300		
		T _A = -55°C to +125°C		400		400		
Oscillator Frequency	C _{OSC} = 1pF, LV to GND (Note 2)	V+ = 5V	5		10	kHz		
		V+ = 2V	1					
Power Efficiency	R _L = 5kΩ, T _A = +25°C, f _{OSC} 5kHz, LV open	95	98		95	98	%	
Voltage Conversion Efficiency	R _L = ∞, T _A = +25°C, LV open	97.0	99.9		99.0	99.9	%	
Oscillator Sink or Source Current	V _{OSC} = 0V or V+, LV open	Pin 1 = 0V		3			µA	
		Pin 1 = V+		20				
Oscillator Impedance	T _A = +25°C	V+ = 2V		1.0		1.0	MΩ	
		V+ = 5V		100		100	kΩ	

Note 1: The Maxim ICL7660 and MAX1044 can operate without an external output diode over the full temperature and voltage ranges. The Maxim ICL7660 can also be used with an external output diode in series with pin 5 (cathode at V_{OUT}) when replacing the Intersil ICL7660. Tests are performed without diode in circuit.

Note 2: f_{OSC} is tested with C_{OSC} = 100pF to minimize the effects of test fixture capacitance loading. The 1pF frequency is correlated to this 100pF test point, and is intended to simulate pin 7's capacitance when the device is plugged into a test socket with no external capacitor. For this test, the LV pin is connected to GND for comparison to the original manufacturer's device, which automatically connects this pin to GND for (V+ > 3V).

Typical Operating Characteristics

(V+ = 5V; C_{BYPASS} = 0.1μF; C₁ = C₂ = 10μF; LV = open; OSC = open; T_A = +25°C; unless otherwise noted.)

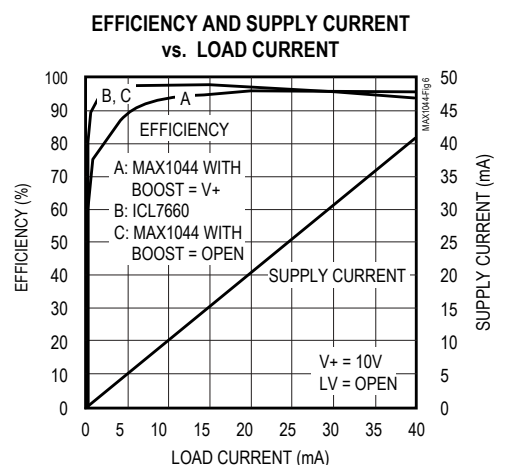
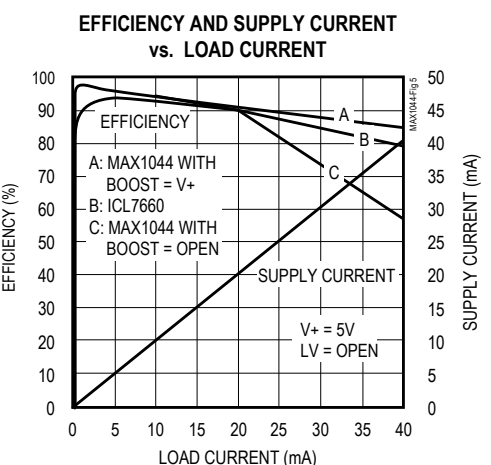
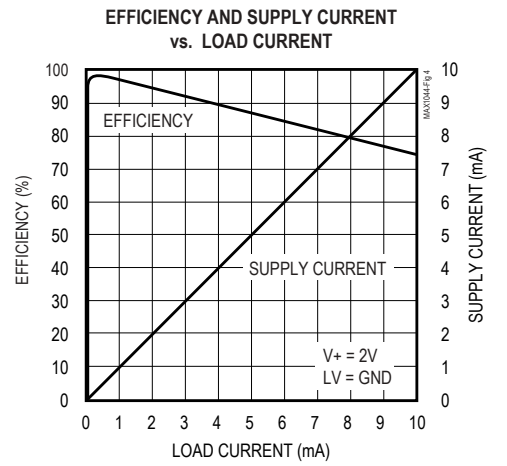
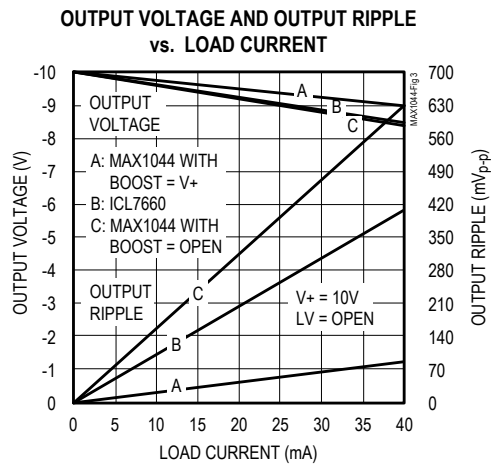
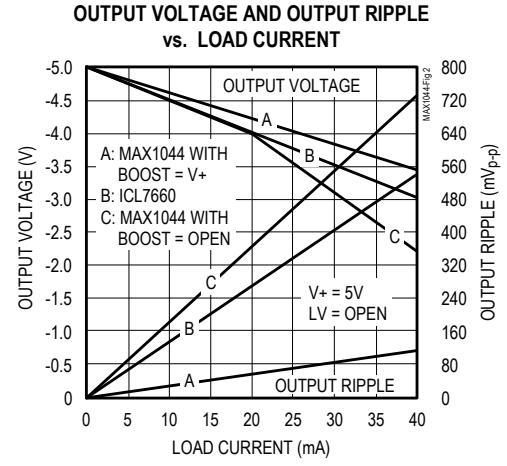
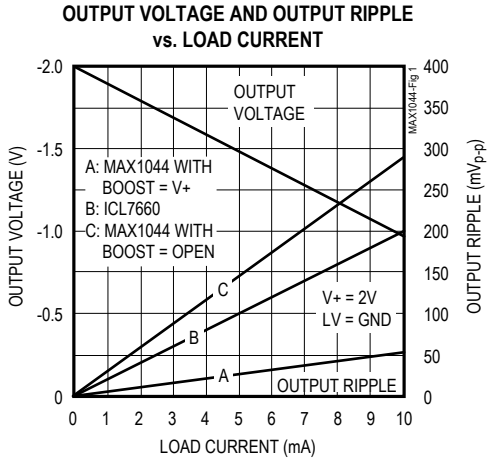

Typical Operating Characteristics

(TA = +25°C, unless otherwise noted.)

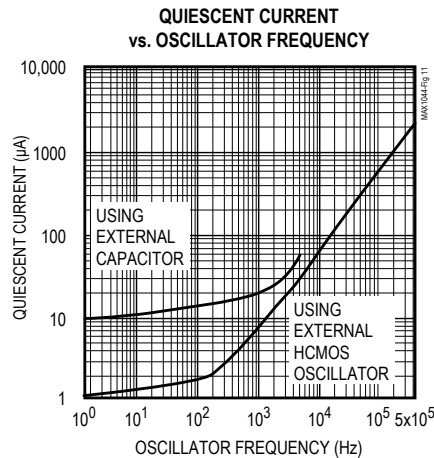
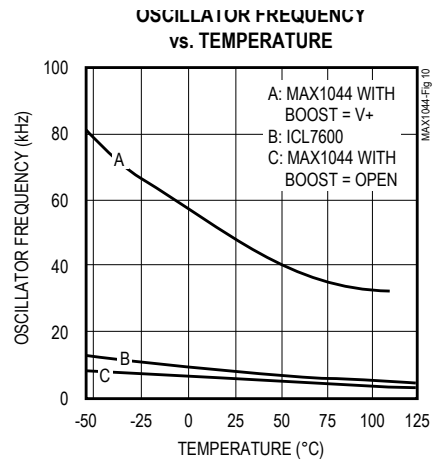
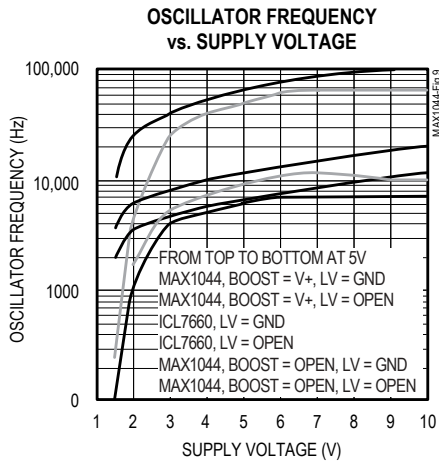
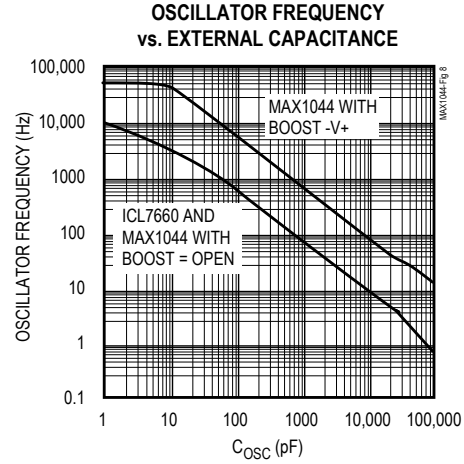
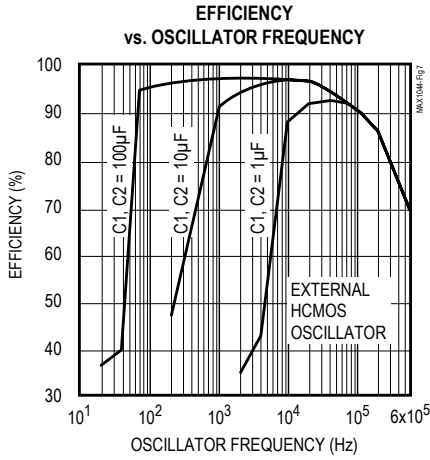

Typical Operating Characteristics (continued)

($V_A = 5.25V$, $C_{BYPASS} = 0.1\mu F$, $C_1 = C_2 = 10\mu F$; LV = open; OSC = open; $T_A = +25^\circ C$; unless otherwise noted.)

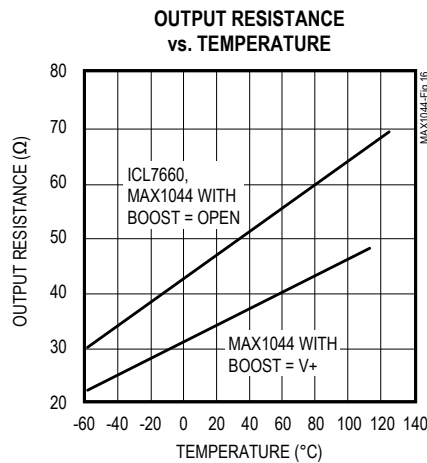
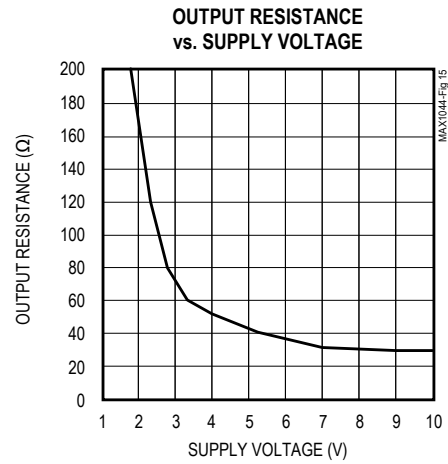
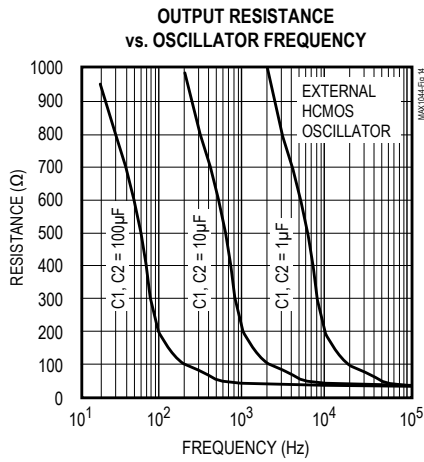
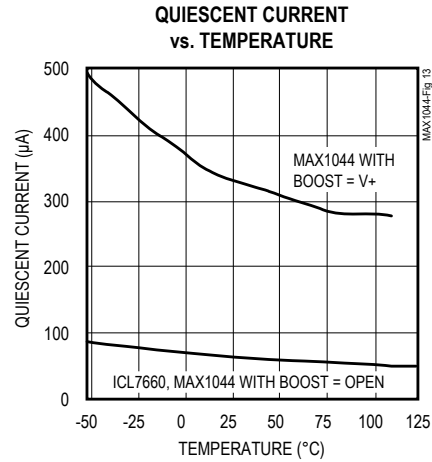
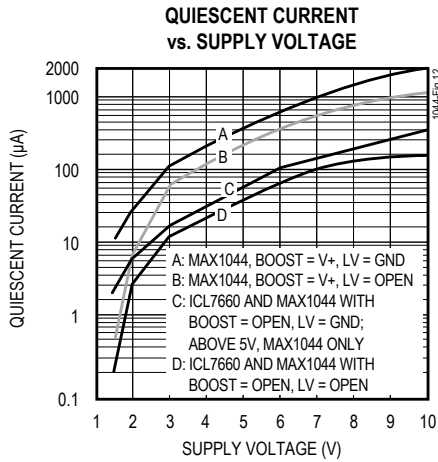

Pin Description

PIN	NAME	FUNCTION
1	BOOST (MAX1044)	Frequency Boost. Connecting BOOST to V+ increases the oscillator frequency by a factor of six. When the oscillator is driven externally, BOOST has no effect and should be left open.
	N.C. (ICL7660)	No Connection
2	CAP+	Connection to positive terminal of Charge-Pump Capacitor
3	GND	Ground. For most applications, the positive terminal of the reservoir capacitor is connected to this pin.
4	CAP-	Connection to negative terminal of Charge-Pump Capacitor
5	V _{OUT}	Negative Voltage Output. For most applications, the negative terminal of the reservoir capacitor is connected to this pin.
6	LV	Low-Voltage Operation. Connect to ground for supply voltages below 3.5V. ICL7660: Leave open for supply voltages above 5V.
7	OSC	Oscillator Control Input. Connecting an external capacitor reduces the oscillator frequency. Minimize stray capacitance at this pin.
8	V+	Power-Supply Positive Voltage Input. (1.5V to 10V). V+ is also the substrate connection.

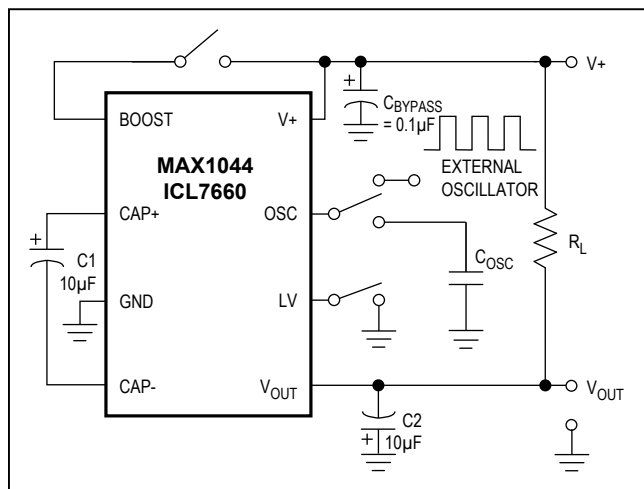

Figure 1. Maxim MAX1044/ICL7660 Test Circuit

Detailed Description

The MAX1044/ICL7660 are charge-pump voltage converters. They work by first accumulating charge in a bucket capacitor and then transfer it into a reservoir capacitor. The ideal voltage inverter circuit in Figure 2 illustrates this operation.

During the first half of each cycle, switches S1 & S3 close and switches S2 & S4 open, which connects the bucket capacitor C1 across V+ and charges C1. During the second half of each cycle, switches S2 & S4 close and switches S1 & S3 open, which connects the positive

terminal of C1 to ground and shifts the negative terminal to V_{OUT}. This connects C1 in parallel with the reservoir capacitor C2. If the voltage across C2 is smaller than the voltage across C1, then charge flows from C1 to C2 until the voltages across them are equal. During successive cycles, C1 will continue pouring charge into C2 until the voltage across C2 reaches - (V+). In an actual voltage inverter, the output is less than - (V+) since the switches S1–S4 have resistance and the load drains charge from C2.

Additional qualities of the MAX1044/ICL7660 can be understood by using a switched-capacitor circuit model. Switching the bucket capacitor, C1, between the input and output of the circuit synthesizes a resistance (Figures 3a and 3b.)

When the switch in Figure 3a is in the left position, capacitor C1 charges to V+. When the switch moves to the right position, C1 is discharged to V_{OUT}. The charge transferred per cycle is: ΔQ = C1(V+ - V_{OUT}). If the switch is cycled at frequency f, then the resulting current is: I = f x ΔQ = f x C1(V+ - V_{OUT}). Rewriting this equation in Ohm's law form defines an equivalent resistance synthesized by the switched-capacitor circuit where:

$$I = \frac{(V+ - V_{OUT})}{1/(f \times C1)}$$

and

$$R_{EQUIV} = \frac{1}{f \times C1}$$

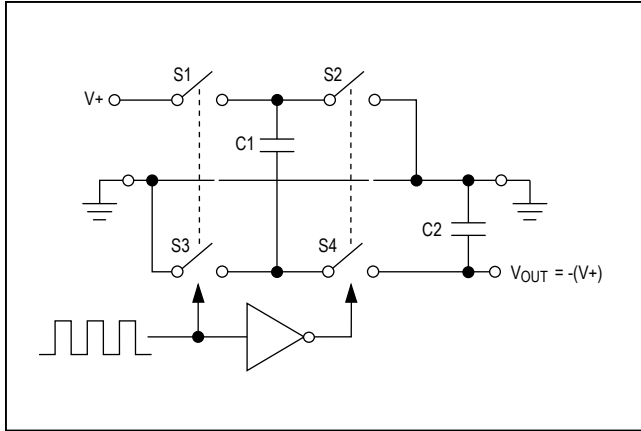

Figure 2. Ideal Voltage Inverter

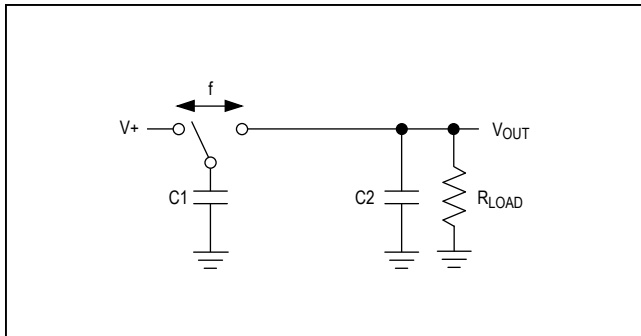

Figure 3a. Switched Capacitor Model

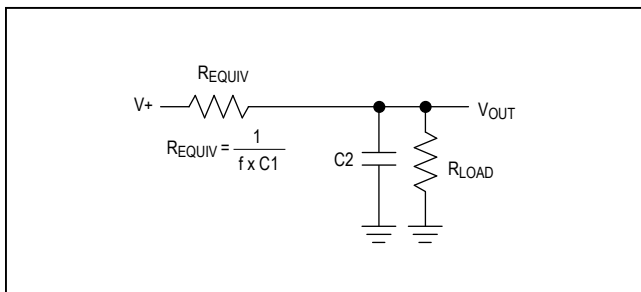

Figure 3b. Equivalent Circuit

where f is one-half the oscillator frequency. This resistance is a major component of the output impedance of switched-capacitor circuits like the MAX1044/ICL7660.

As shown in Figure 4, the MAX1044/ICL7660 contain MOSFET switches, the necessary transistor drive circuitry, and a timing oscillator.

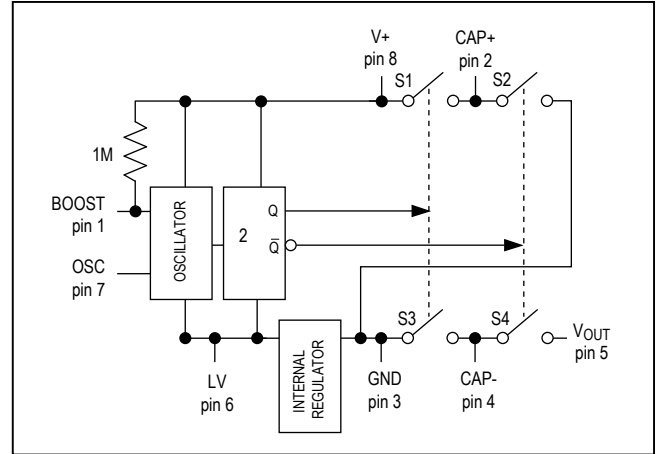

Figure 4. MAX1044 and ICL7660 Functional Diagram

Design Information

The MAX1044/ICL7660 are designed to provide a simple, compact, low-cost solution where negative or doubled supply voltages are needed for a few low-power components. Figure 5 shows the basic negative voltage converter circuit. For many applications, only two external capacitors are needed. The type of capacitor used is not critical.

Proper Use of the Low-Voltage (LV) Pin

Figure 4 shows an internal voltage regulator inside the MAX1044/ICL7660. Use the LV pin to bypass this regulator, in order to improve low-voltage performance and allow operation down to 1.5V. For low-voltage operation and compatibility with the industry-standard LTC1044 and ICL7660, the LV pin should be connected to ground for supply voltages below 3.5V and left open for supply voltages above 3.5V.

The MAX1044's LV pin can be grounded for all operating conditions. The advantage is improved low-voltage performance and increased oscillator frequency. The disadvantage is increased quiescent current and reduced efficiency at higher supply voltages. For Maxim's ICL7660, the LV pin must be left open for supply voltages above 5V.

When operating at low supply voltages with LV open, connections to the LV, BOOST, and OSC pins should be short or shielded to prevent EMI from causing oscillator jitter.

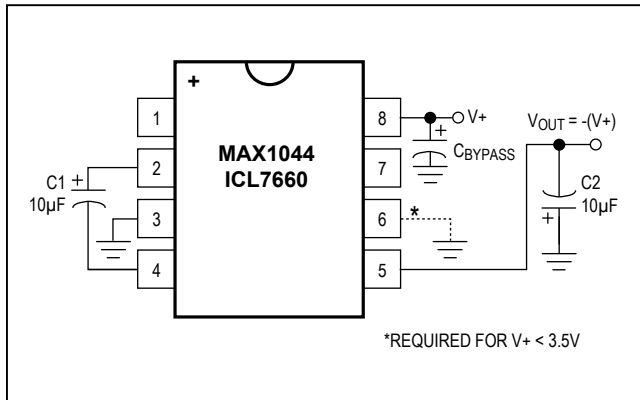

Figure 5. Basic Negative Voltage Converter

Oscillator Frequency Considerations

For normal operation, leave the BOOST and OSC pins of the MAX1044/ICL7660 open and use the nominal oscillator frequency. Increasing the frequency reduces audio interference, output resistance, voltage ripple, and required capacitor sizes. Decreasing frequency reduces quiescent current and improves efficiency.

Oscillator Frequency Specifications

The MAX1044/ICL7660 do not have a precise oscillator frequency. Only minimum values of 1kHz and 5kHz for the MAX1044 and a typical value of 10kHz for the ICL7660 are specified. If a specific oscillator frequency is required, use an external oscillator to drive the OSC pin.

Increasing Oscillator Frequency Using the BOOST Pin

For the MAX1044, connecting the BOOST pin to the V+ pin raises the oscillator frequency by a factor of about 6. Figure 6 shows this connection. Higher frequency operation lowers output impedance, reduces output ripple, allows the use of smaller capacitors, and shifts switching noise out of the audio band. When the oscillator is driven externally, BOOST has no effect and should be left open. The BOOST pin should also be left open for normal operation.

Reducing the Oscillator Frequency Using C_{OSC}

An external capacitor can be connected to the OSC pin to lower the oscillator frequency (Figure 6). Lower frequency operation improves efficiency at low load currents by reducing the IC's quiescent supply current. It also increases output ripple and output impedance. This can be offset by using larger values for C1 and C2.

Connections to the OSC pin should be short to prevent stray capacitance from reducing the oscillator frequency.

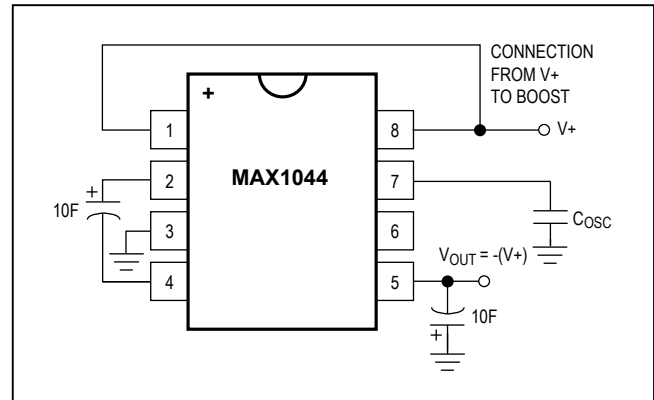
Figure 6. Negative Voltage Converter with C_{OSC} and BOOST

Overdriving the OSC Pin with an External Oscillator

Driving OSC with an external oscillator is useful when the frequency must be synchronized, or when higher frequencies are required to reduce audio interference. The MAX1044/ICL7660 can be driven up to 400kHz. The pump and output ripple frequencies are one-half the external clock frequency. Driving the MAX1044/ICL7660 at a higher frequency increases the ripple frequency and allows the use of smaller capacitors. It also increases the quiescent current.

The OSC input threshold is $V+ - 2.5V$ when $V+ \geq 5V$, and is $V+ / 2$ for $V+ < 5V$. If the external clock does not swing all the way to V+, use a 10k Ω pull-up resistor (Figure 7).

Output Voltage Considerations

The MAX1044/ICL7660 output voltage is not regulated. The output voltages will vary under load according to the output resistance. The output resistance is primarily a function of oscillator frequency and the capacitor value. Oscillator frequency, in turn, is influenced by temperature and supply voltage. For example, with a 5V input voltage and 10 μ F charge-pump capacitors, the output resistance is typically 50 Ω . Thus, the output voltage is about -5V under light loads, and decreases to about -4.5V with a 10mA load current.

Minor supply voltage variations that are inconsequential to digital circuits can affect some analog circuits. Therefore, when using the MAX1044/ICL7660 for powering sensitive analog circuits, the power-supply rejection ratio of those circuits must be considered. The output ripple and output drop increase under heavy loads. If necessary, the MAX1044/ICL7660 output impedance can be reduced by paralleling devices, increasing the capacitance of C1 and C2, or connecting the MAX1044's BOOST pin to V+ to increase the oscillator frequency.

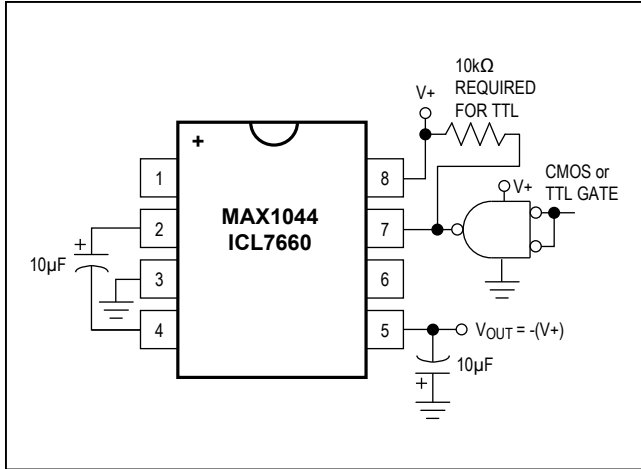

Figure 7. External Clocking

Inrush Current and EMI Considerations

During start-up, pump capacitors C1 and C2 must be charged. Consequently, the MAX1044/ICL7660 develop inrush currents during start-up. While operating, short bursts of current are drawn from the supply to C1, and then from C1 to C2 to replenish the charge drawn by the load during each charge-pump cycle. If the voltage converters are being powered by a high-impedance source, the supply voltage may drop too low during the current bursts for them to function properly. Furthermore, if the supply or ground impedance is too high, or if the traces between the converter IC and charge-pump capacitors are long or have large loops, switching noise and EMI may be generated. To reduce these effects:

- 1) Power the MAX1044/ICL7660 from a low-impedance source.
- 2) Add a power-supply bypass capacitor with low effective series resistance (ESR) close to the IC between the V+ and ground pins.
- 3) Shorten traces between the IC and the charge-pump capacitors.
- 4) Arrange the components to keep the ground pins of the capacitors and the IC as close as possible.
- 5) Leave extra copper on the board around the voltage converter as power and ground planes. This is easily done on a double-sided PC board.

Efficiency, Output Ripple, and Output Impedance

The power efficiency of a switched-capacitor voltage converter is affected by the internal losses in the converter IC, resistive losses of the pump capacitors, and conversion losses during charge transfer between the capacitors. The total power loss is:

$$\Sigma P_{LOSS} = P_{INTERNAL\ LOSSES} + P_{SWITCH\ LOSSES} + P_{PUMP\ CAPACITOR\ LOSSES} + P_{CONVERSION\ LOSSES}$$

The internal losses are associated with the IC’s internal functions such as driving the switches, oscillator, etc. These losses are affected by operating conditions such as input voltage, temperature, frequency, and connections to the LV, BOOST, and OSC pins.

The next two losses are associated with the output resistance of the voltage converter circuit. Switch losses occur because of the on-resistances of the MOSFET switches in the IC. Charge-pump capacitor losses occur because of their ESR. The relationship between these losses and the output resistance is as follows:

$$P_{PUMP\ CAPACITOR\ LOSSES} + P_{SWITCH\ LOSSES} = I_{OUT}^2 \times R_{OUT}$$

where:

$$R_{OUT} \cong \frac{1}{(f_{OSC} / 2) \times C1} + 4(2R_{SWITCHES} + E_{SRC1}) + E_{SRC2}$$

and f_{OSC} is the oscillator frequency.

The first term is the effective resistance from the switched-capacitor circuit.

Conversion losses occur during the transfer of charge between capacitors C1 and C2 when there is a voltage difference between them. The power loss is:

$$P_{CONV.LOSS} \cong \left[\frac{1}{2} C1 \left((V+)^2 - V_{OUT}^2 \right) + \frac{1}{2} C2 \left(V_{RIPPLE}^2 - 2V_{OUT} V_{RIPPLE} \right) \right] \times f_{OSC} / 2$$

Increasing Efficiency

Efficiency can be improved by lowering output voltage ripple and output impedance. Both output voltage ripple and output impedance can be reduced by using large capacitors with low ESR.

The output voltage ripple can be calculated by noting that the output current is supplied solely from capacitor C2 during one-half of the charge-pump cycle.

$$V_{RIPPLET} \cong \left(\frac{1}{2 \times f_{OSC} \times C2} + 2 \times ESR_{C2} \right) I_{OUT}$$

Slowing the oscillator frequency reduces quiescent current. The oscillator frequency can be reduced by connecting a capacitor to the OSC pin.

Reducing the oscillator frequency increases the ripple voltage in the MAX1044/ICL7660. Compensate by increasing the values of the bucket and reservoir capacitors. For example, in a negative voltage converter, the pump frequency is around 4kHz or 5kHz. With the recommended 10µF bucket and reservoir capacitors, the circuit consumes about 70µA of quiescent current while providing 20mA of output current. Setting the oscillator to 400Hz by connecting a 100pF capacitor to OSC reduces the quiescent current to about 15µA. Maintaining 20mA output current capability requires increasing the bucket and reservoir capacitors to 100µF.

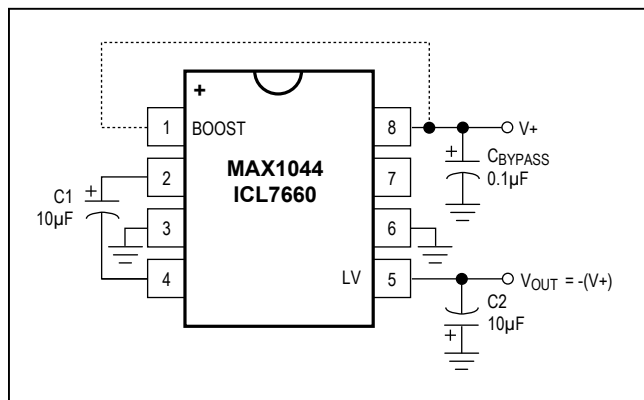

Figure 8. Negative Voltage Converter with BOOST and LV Connections

Note that lower capacitor values can be used for lower output currents. For example, setting the oscillator to 40Hz by connecting a 1000pF capacitor to OSC provides the highest efficiency possible. Leaving the bucket and reservoir capacitors at 100µF gives a maximum I_{OUT} of 2mA, a no-load quiescent current of 10µA, and a power conversion efficiency of 98%.

General Precautions

- 1) Connecting any input terminal to voltages greater than V+ or less than ground may cause latchup. Do not apply any input sources operating from external supplies before device power-up.
- 2) Never exceed maximum supply voltage ratings.
- 3) Do not connect C1 and C2 with the wrong polarity.
- 4) Do not short V+ to ground for extended periods with supply voltages above 5.5V present on other pins.
- 5) Ensure that V_{OUT} (pin 5) does not go more positive than GND (pin 3). Adding a diode in parallel with C2, with the anode connected to V_{OUT} and cathode to LV, will prevent this condition.

Application Circuits

Negative Voltage Converter

Figure 8 shows a negative voltage converter, the most popular application of the MAX1044/ICL7660. Only two external capacitors are needed. A third power-supply bypass capacitor is recommended (0.1µF to 10µF)

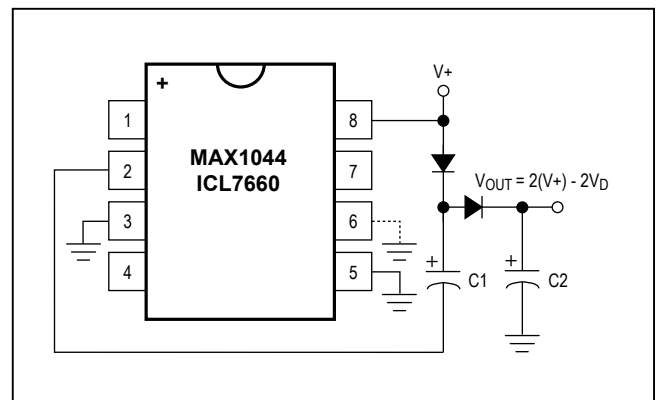

Figure 9. Voltage Doubler

Positive Voltage Doubler

Figure 9 illustrates the recommended voltage doubler circuit for the MAX1044/ICL7660. To reduce the voltage drops contributed by the diodes (V_D), use Schottky diodes. For true voltage doubling or higher output currents, use the MAX660.

Voltage Divider

The voltage divider shown in Figure 10 splits the power supply in half. A third capacitor can be added between $V+$ and V_{OUT} .

Combined Positive Multiplication and Negative Voltage Conversion

Figure 11 illustrates this dual-function circuit. Capacitors C1 and C3 perform the bucket and reservoir functions for generating the negative voltage. Capacitors C2 and C4 are the bucket and reservoir capacitors for the doubled

positive voltage. This circuit has higher output impedances resulting from the use of a common charge-pump driver.

Cascading Devices

Larger negative multiples of the supply voltage can be obtained by cascading MAX1044/ICL7660 devices (Figure 12). The output voltage is nominally $V_{OUT} = -n(V+)$ where n is the number of devices cascaded. The output voltage is reduced slightly by the output resistance of the first device, multiplied by the quiescent current of the second, etc. Three or more devices can be cascaded in this way, but output impedance rises dramatically. For example, the output resistance of two cascaded MAX1044s is approximately five times the output resistance of a single voltage converter. A better solution may be an inductive switching regulator, such as the MAX755, MAX759, MAX764, or MAX774.

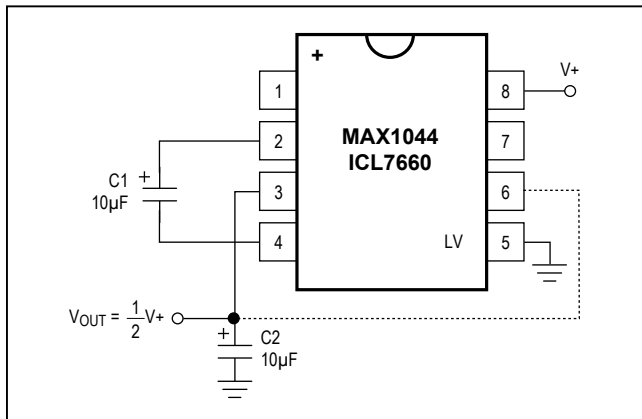

Figure 10. Voltage Divider

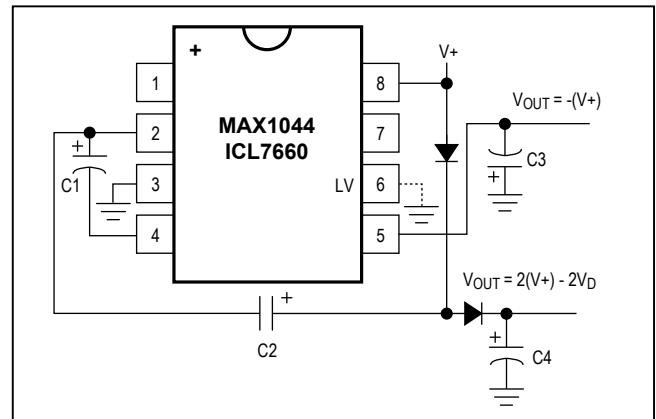

Figure 11. Combined Positive and Negative Converter

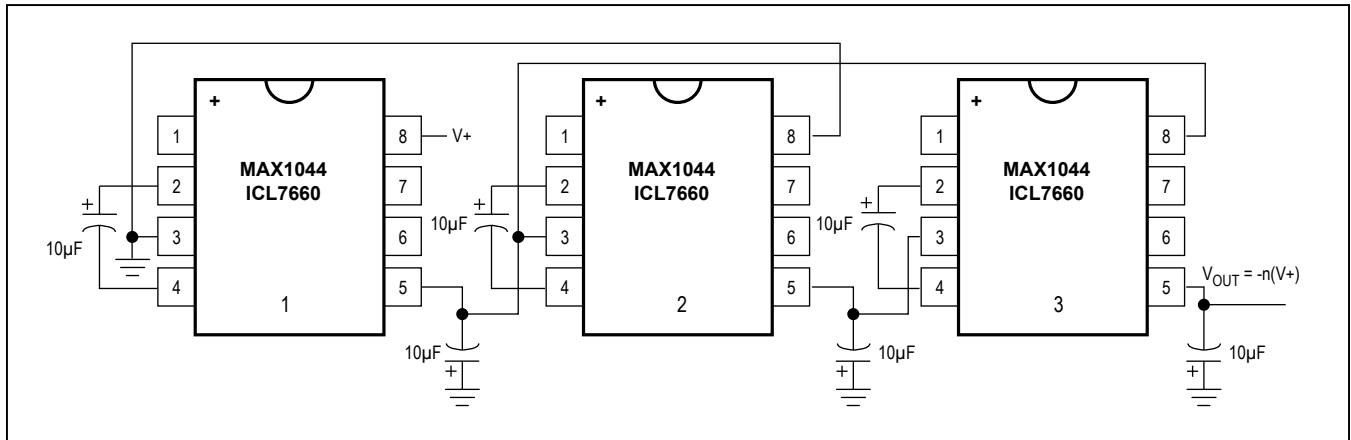

Figure 12. Cascading MAX1044/ICL7660 for Increased Output Voltage

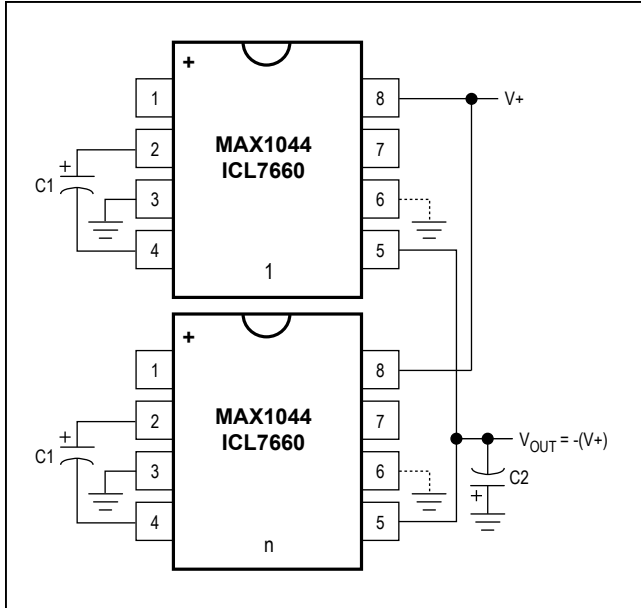

Figure 13. Paralleling MAX1044/ICL7660 to Reduce Output Resistance

Paralleling Devices

Paralleling multiple MAX1044/ICL7660s reduces output resistance and increases current capability. As illustrated in Figure 13, each device requires its own pump capacitor C1, but the reservoir capacitor C2 serves all devices. The equation for calculating output resistance is:

$$R_{OUT} = \frac{R_{OUT} \text{ (of MAX1044 or ICL7660)}}{n \text{ (number of devices)}}$$

Shutdown Schemes

Figures 14a–14c illustrate three ways of adding shutdown capability to the MAX1044/ICL7660. When using these circuits, be aware that the additional capacitive loading on the OSC pin will reduce the oscillator frequency. The first circuit has the least loading on the OSC pin and has the added advantage of controlling shutdown with a high or low logic level, depending on the orientation of the switching diode.

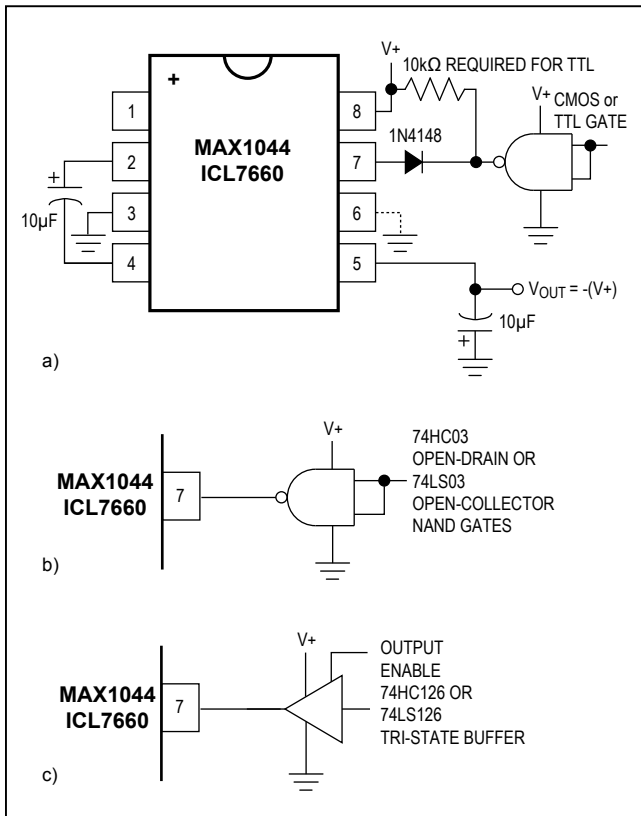

Figure 14a-14c. Shutdown Schemes for MAX1044/ICL7660

Ordering Information

PART	TEMP. RANGE	PIN-PACKAGE
MAX1044CPA	0°C to +70°C	8 Plastic DIP
MAX1044CSA	0°C to +70°C	8 SO
MAX1044C/D*	0°C to +70°C	Dice*
MAX1044EPA	-40°C to +85°C	8 Plastic DIP
MAX1044ESA	-40°C to +85°C	8 SO
MAX1044MJA	-55°C to +125°C	8 CERDIP**
ICL7660CPA	0°C to +70°C	8 Plastic DIP
ICL7660CSA	0°C to +70°C	8 SO
ICL7660CUA	0°C to +70°C	8 µMAX
ICL7660C/D	0°C to +70°C	Dice*
ICL7660EPA	-40°C to +85°C	8 Plastic DIP
ICL7660ESA	-40°C to +85°C	8 SO
ICL7660AMJA†	-55°C to +125°C	8 CERDIP**
ICL7660AMTV†	-55°C to +125°C	8 TO-99**

*Contact factory for dice specifications. Dice are not tested

**Contact factory for availability.

†The Maxim ICL7660 meets or exceeds all “A” and “S” specifications.

Chip Topographies

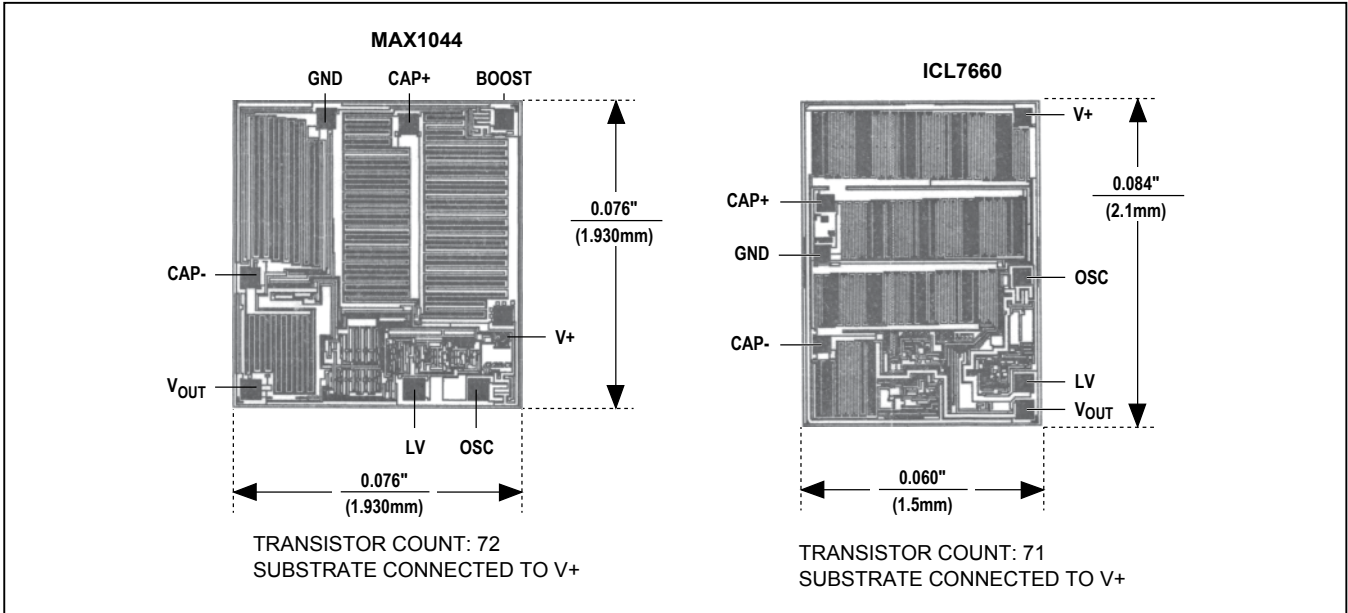

Package Information

For the latest package outline information and land patterns (footprints), go to www.maximintegrated.com/packages. Note that a “+”, “#”, or “-” in the package code indicates RoHS status only. Package drawings may show a different suffix character, but the drawing pertains to the package regardless of RoHS status.

PACKAGE TYPE	PACKAGE CODE	OUTLINE NO.	LAND PATTERN NO.
6 TDFN-EP	T633-2	21-0036	90-0058
8 Plastic DIP	P8+1	21-0043	—
8 SOIC	S8+2	21-0041	90-0096
8 CERDIP	J8+2	21-0045	—
8 μMAX	U8+1	21-0036	90-0092
8 TO-99	T99-8	21-0022	—

Revision History

REVISION NUMBER	REVISION DATE	DESCRIPTION	PAGES CHANGED
2	2/17	Updated part numbers in <i>Ordering Information</i> table	13

For pricing, delivery, and ordering information, please contact Maxim Direct at 1-888-629-4642, or visit Maxim Integrated's website at www.maximintegrated.com.

Maxim Integrated cannot assume responsibility for use of any circuitry other than circuitry entirely embodied in a Maxim Integrated product. No circuit patent licenses are implied. Maxim Integrated reserves the right to change the circuitry and specifications without notice at any time. The parametric values (min and max limits) shown in the Electrical Characteristics table are guaranteed. Other parametric values quoted in this data sheet are provided for guidance.