

# OA172LFG Series

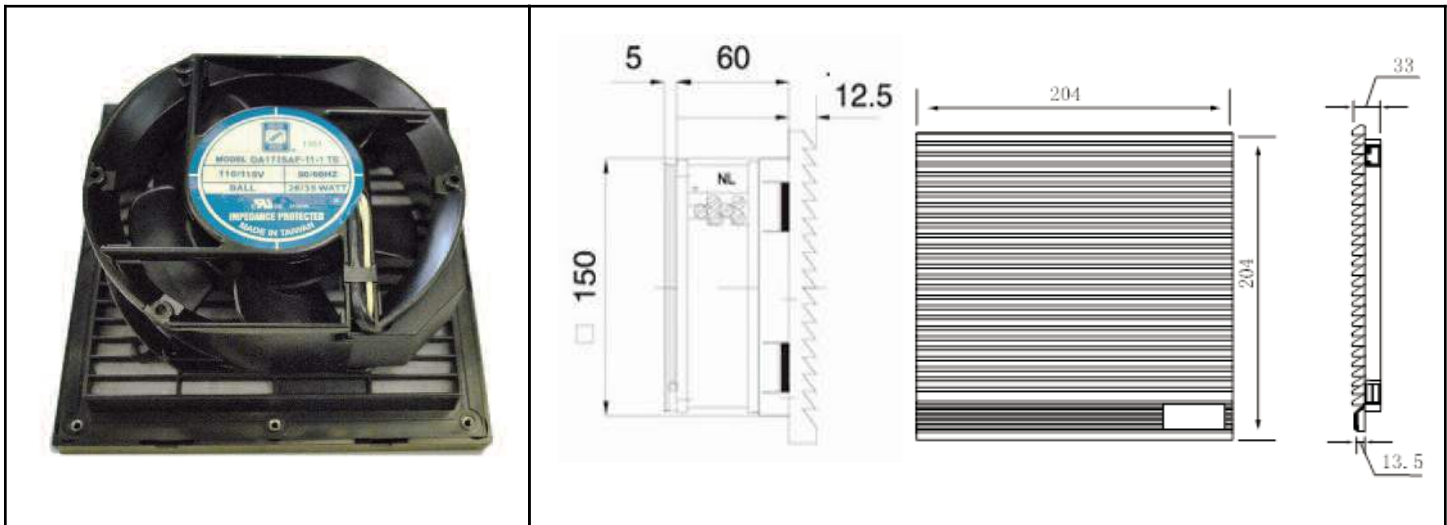

## Louvered Filter Fan Kit with Fan Installed



Frame	Diecast Aluminum	Operating Temperature Ball Bearing -40C ~ +70C  Life Expectancy Ball Bearing 60,000 hours (L10 at 40C)  Environmental: Class B Insulation Rated IP54 Guard Guard Frame: ABS Resin UL94V-0 with UV protection Color: Black (standard) or Gray Filter Mesh: Nylon fiber Synthetic Resin	
Impeller	PBT, UL94V-O plastic		
Connection	2x Lead Wires or Terminals		
Motor	Capacitor drive, impedance protected		
Bearing System	Dual ball		
Insulation Resistance	>100M ohm between lead-wire and frame (500VDC)		
Dielectric Strength	1 min at 1500 VAC, 50/60Hz		

Model Number	OA172LFG111T	OA172LFG221T
Nominal Voltage	115 VAC	230 VAC
Voltage Range	80 ~ 130 VAC	160 ~ 260 VAC
Rated Power	35 W	35 W
Rated Speed (RPM)	3200	3200
Airflow (CFM)	235	235
Noise Level (dB)	52	52
Max. Static Pressure	0.70 "H2O	0.70 "H2O

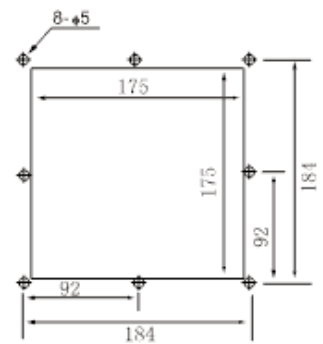

PANEL CUTOUT

\* Note: Airflow data is for the fan without the louvered filter attached. Calculations indicate that up to a 40% reduction (~ 141 CFM) in fan airflow is possible with LFG unit installed.