

CIPOS™ Micro IPM 600 V, 6 A

IM241 Series

Description

IM241-L6 is a 3-phase Intelligent Power Module (IPM) designed for high-efficiency appliance motor drives such as fans and pumps. This IPM is available in fast speed variant for low loss operation.

Features

- 600V 3-phase inverter including gate drivers & bootstrap function
- Reverse Conducting IGBT Gen 2 (RCD2) optimized for motor drives
- Temperature monitor
- Accurate overcurrent shutdown ($\pm 5\%$)
- Fault reporting and programmable fault clear
- Advanced input filter with shoot-through protection
- Optimized dV/dt for loss and EMI trade offs
- Open-emitter for single and leg-shunt current sensing
- 3.3V logic compatible
- Isolation 2000VRMS, 1min

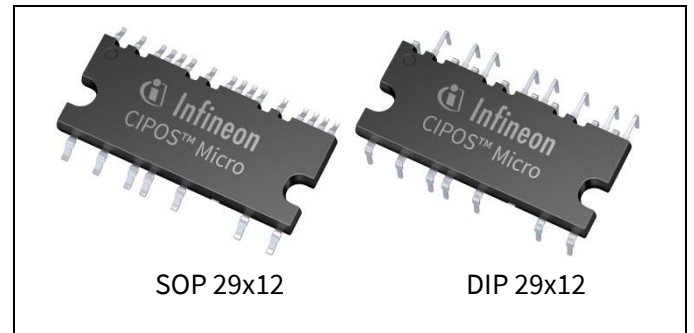

Potential Applications

- Fans
- Pumps

Product validation

Qualified for industrial applications according to the relevant tests of JEDEC47/20/22.

Table 1 Product Information

Base Part Number	Package Type	Standard Pack	
		Form	Quantity
IM241-L6T2y	DIP 29x12	Tube	240
IM241-L6S1y	SOP 29x12	Tube	240
		Tape & Reel	500

y = B (fast speed for low losses; for x = S, M, L) or J (slow speed for low EMI; for x = S, M)

Table of contents

Table of contents

Description1

Features 1

Potential Applications.....	1
Product validation	1
Table of contents.....	2
1 Internal Electrical Schematic	3
2 Pin Configuration.....	4
2.1 Pin Assignment.....	4
2.2 Pin Descriptions.....	5
3 Absolute Maximum Rating	7
3.1 Module	7
3.2 Inverter	7
3.3 Control.....	7
4 Thermal Characteristics	8
5 Recommended Operating Conditions.....	9
6 Static Parameters	10
6.1 Inverter	10
6.2 Control.....	10
7 Dynamic Parameters.....	12
7.1 Inverter	12
7.2 Control.....	12
8 Thermistor Characteristics	14
9 Mechanical Characteristics and Ratings.....	15
10 Qualification Information	16
11 Diagrams & Tables	17
11.1 T _c Measurement Point.....	17
11.2 Backside Curvature Measurement Points	17
11.3 Input-Output Logic Table.....	18
11.4 Switching Time Definitions	19
12 Application Guide	20
12.1 Typical Application Schematic	20
12.2 T _J vs T _{TH}	21
12.3 -V _S Immunity	22
13 Package Outline	23
13.1 DIP 29x12	23
13.2 SOP 29x12.....	24
14 Revision History	25

1 Internal Electrical Schematic

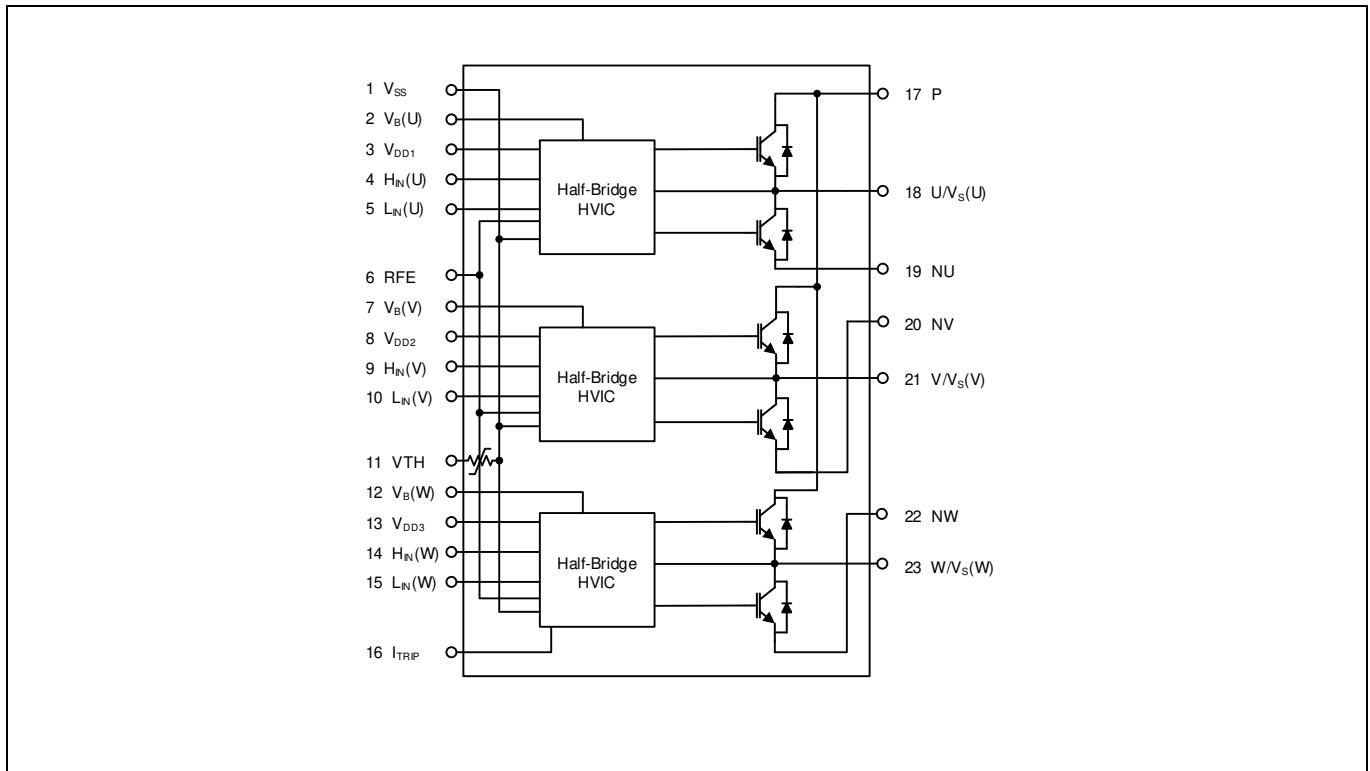

Figure 1 Internal electrical schematic.

2 Pin Configuration

2.1 Pin Assignment

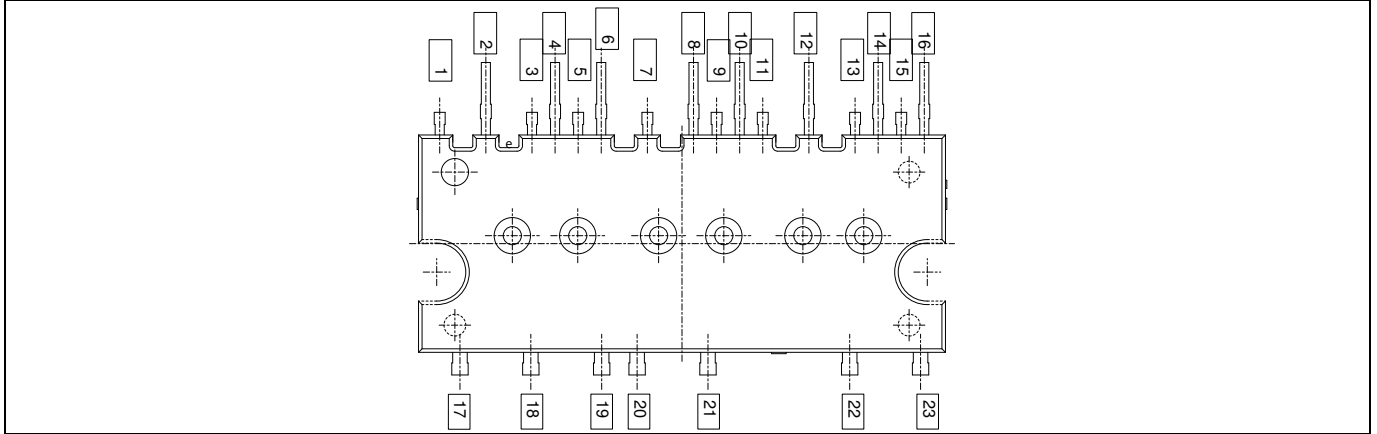

Figure 2 Module pinout

Table 2 Pin Assignment

Pin	Name	Description
1	V _{SS}	Logic ground
2	V _{B(U)}	U-phase high-side floating IC supply voltage
3	V _{DD1}	Low-side control supply 1
4	H _{IN(U)}	U-phase high-side gate driver input
5	L _{IN(U)}	U-phase low-side gate driver input
6	RFE	RCIN / Fault / Enable
7	V _{B(V)}	V-phase high-side floating IC supply voltage
8	V _{DD2}	Low-side control supply 2
9	H _{IN(V)}	V-phase high-side gate driver input
10	L _{IN(V)}	V-phase low-side gate driver input
11	V _{TH}	Thermistor output
12	V _{B(W)}	W-phase high-side floating IC supply voltage
13	V _{DD3}	Low-side control supply 3
14	H _{IN(W)}	W-phase high-side gate driver input
15	L _{IN(W)}	W-phase low-side gate driver input
16	I _{TRIP}	Over-current protection input
17	P	DC bus voltage positive
18	U/V _{S(U)}	Motor U-phase output, U-phase high-side floating IC supply offset voltage
19	NU	U-phase low-side emitter
20	NV	U-phase low-side emitter - phase low-side emitter
21	V/V _{S(V)}	Motor V-phase output, V-phase high-side floating IC supply offset voltage
22	NW	W-phase low-side emitter
23	W/V _{S(W)}	Motor W-phase output, W-phase high-side floating IC supply offset voltage

2.2 Pin Descriptions

$H_{IN}(U,V,W)$ and $L_{IN}(U,V,W)$ (Low side and high side control pins)

These pins are positive logic and they are responsible for the control of the integrated IGBT. The Schmitt-trigger input thresholds of them are such to guarantee LSTTL and CMOS compatibility down to 3.3V controller outputs. Pull-down resistor of about 800kΩ is internally provided to pre-bias inputs during supply start-up and an ESD diode is provided for pin protection purposes. Input Schmitt-trigger and noise filter provide beneficial noise rejection to short input pulses.

The noise filter suppresses control pulses which are below the filter time T_{FILIN} . The filter acts according to Figure 4.

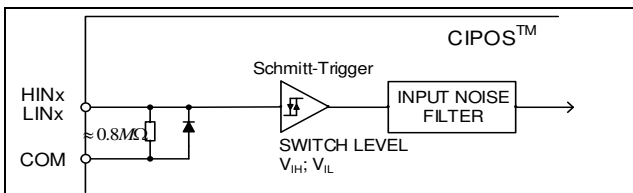

Figure 3 Input pin structure

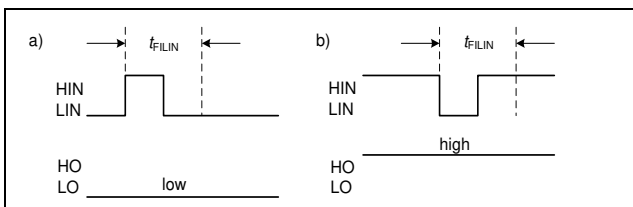

Figure 4 Input filter timing diagram

The integrated gate drive provides additionally a shoot through prevention capability which avoids the simultaneous on-state of the high-side and low-side switch of the same inverter phase. A minimum deadtime insertion of typically 300ns is also provided by driver IC, in order to reduce cross-conduction of the external power switches.

V_{DDX} , V_{SS} (Low side control supply and reference)

V_{DD} is the control supply and it provides power both to input logic and to the output power stage. Input logic is referenced to V_{SS} ground.

The under-voltage circuit enables the device to operate at power on when a supply voltage of at least a typical voltage of $V_{DDUV+} = 11.1V$ is present.

The IC shuts down all the gate drivers power outputs, when the V_{DD} supply voltage is below $V_{DDUV-} = 10.9V$. This prevents the external power switches from critically low gate voltage levels during on-state and therefore from excessive power dissipation.

$V_B(U,V,W)$ and $V_S(U,V,W)$ (High side supplies)

V_B to V_S is the high side supply voltage. The high side circuit can float with respect to V_{SS} following the external high side power device source voltage.

Due to the low power consumption, the floating driver stage is supplied by integrated bootstrap circuit.

The under-voltage detection operates with a rising supply threshold of typical $V_{BSUV+} = 11.1V$ and a falling threshold of $V_{BSUV-} = 10.9V$.

$V_S(U,V,W)$ provide a high robustness against negative voltage in respect of V_{SS} . This ensures very stable designs even under rough conditions.

NU, NV, NW (Low side emitters)

The low side emitters are available for current measurements of each phase leg. It is recommended to keep the connection to pin V_{SS} as short as possible in order to avoid unnecessary inductive voltage drops.

VTH (Thermistor output)

A UL certified NTC resistor is integrated in the module with one terminal of the chip connected to V_{SS} and the other to VTH. When pulled up to a rail voltage such as V_{DD} or 3.3V by a resistor, the VTH pin provides an analog voltage signal corresponding to the temperature of the thermistor.

RFE (RCIN / Fault / Enable)

The RFE pin combines 3 functions in one pin: RCIN or RC-network based programmable fault clear timer, fault output and enable input.

The RFE pin is normally connected to an RC network on the PCB per the schematic in Figure 5. Under normal operating conditions, R_{RCIN} pulls the RFE pin to 3.3V, thus enabling all the functions in the IPM. The microcontroller can pull this pin low to disable the IPM functionality. This is the Enable function.

Pin Configuration

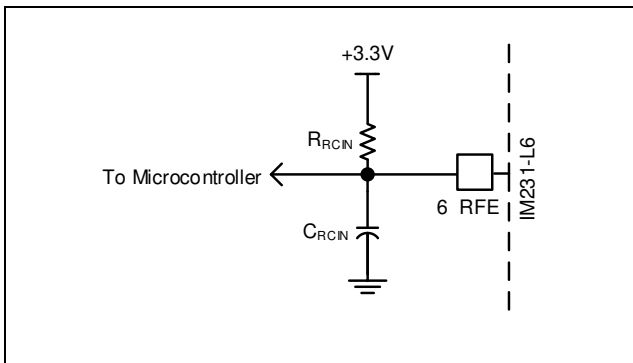

Figure 5 Typical PCB circuit connected to the RFE pin

The Fault function allows the IPM to report a Fault condition to the microcontroller by pulling the RFE pin low in one of two situations. The first is an under-voltage condition on V_{DD} and the second is when the I_{TRIP} pin sees a voltage rising above V_{IT,TH+}.

The programmable fault clear timer function provides a means of automatically re-enabling the module operation a preset amount of time (T_{FLT-CLR}) after the fault condition has disappeared. Figure 6 shows the RFE-related circuit block diagram inside the IPM.

The length of TFLT-CLR can be determined by using the formula below.

$$V_{RFE}(t) = 3.3V * (1 - e^{-t/RC})$$

$$T_{FLT-CLR} = -R_{RCIN} * C_{RCIN} * \ln(1 - V_{RFE+}/3.3V)$$

For example, if R_{RCIN} is 1.2MΩ and C_{RCIN} is 1nF, the T_{FLT-CLR} is about 1.7ms with V_{RFE+} of 2.2V. It is also important to note that C_{RCIN} needs to be minimized in order to make sure it is fully discharged in case of over current event.

Since the I_{TRIP} pin has a 500ns input filter, it is appropriate to ensure that C_{RCIN} will be discharged below V_{RFE-} by the open-drain MOSFET, after 350ns. Therefore, the max C_{RCIN} can be calculated as:

$$V_{RFE}(t) = 3.3V * e^{-t/RC} < V_{RFE-}$$

$$C_{RCIN} < 350ns / (- \ln(V_{RFE-} / 3.3V)) * R_{RFE_ON}$$

Consider V_{RFE-} of 0.8V and R_{RFE_ON} of 50ohm, C_{RCIN} should be less than 5nF. It is also suggested to use a R_{RCIN} of between 0.5MΩ and 2MΩ.

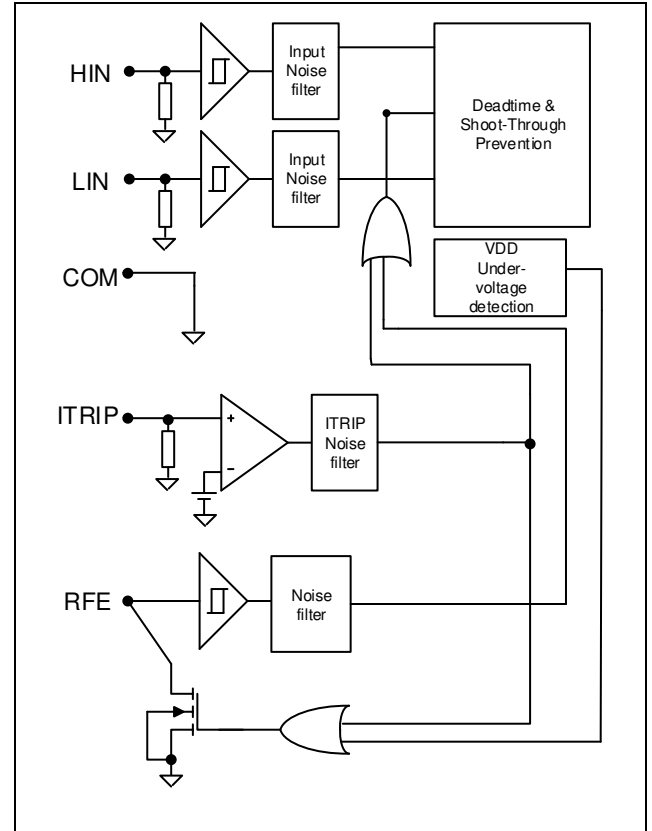

Figure 6 RFE internal circuit structure

U/V_s(U) , V/V_s(V), W/V_s(W) (High side emitter and low side collector)

These pins are connected to motor U, V, W input pins.

P (Positive bus input voltage)

The high side IGBTs are connected to the bus voltage. It is noted that the bus voltage should not exceed 450V.

Absolute Maximum **Rating**

3 Absolute Maximum Rating

3.1 Module

Table 3

Parameter	Symbol	Condition		Units
Storage temperature	T_{STG}		-40 ~ 150	°C
Operating case temperature	T_C		-40 ~ 125	°C
Operating junction temperature	T_J		-40 ~ 150	°C
Isolation test voltage	V_{ISO}	1min, RMS, f = 60Hz	2000	V

3.2 Inverter

Table 4 IM241-L6

Parameter	Symbol	Condition		Units
Max. blocking voltage	V_{CES}/V_{RRM}		600	V
Output current	I_O	$T_C = 25^\circ\text{C}$	6	A
Peak output current	I_{OP}	$T_C = 25^\circ\text{C}, t_p < 1\text{ms}$	9	A
Peak power dissipation per IGBT	P_{tot}	$T_C = 25^\circ\text{C}$	15	W
Short circuit withstand time	T_{SC}	$V_{DD}=15\text{V}, V_{DC} \leq 400\text{V}, T_J=150^\circ\text{C}$ Allowed number of short circuits: <1000, time between short circuit: $\geq 1\text{s}$	3	μs

3.3 Control

Table 5

Parameter	Symbol	Condition		Units
Low side control supply voltage	V_{DD}		-0.3 ~ 20	V
Input voltage	V_{IN}	LIN, HIN, I_{TRIP} , RFE	-0.3 ~ V_{DD}	V
High side floating supply voltage (V_B reference to V_S)	V_{BS}		-0.3 ~ 20	V

4 Thermal Characteristics

Table 6 IM241-L6

Parameter	Symbol	Conditions	Min.	Typ.	Max.	Units
Single IGBT thermal resistance, junction-case	$R_{TH(J-C)}$	Low side V-phase IGBT	-	8.64	10.4	K/W
Single diode thermal resistance, junction-case	$R_{TH(J-C)}$	Low side V-phase Diode	-	9.94	11.9	K/W

5 Recommended Operating Conditions

Table 7

Parameter	Symbol	Min.	Typ.	Max.	Units
Positive DC bus input voltage	P	-	-	450	V
Low side control supply voltage	V _{DD}	13.5	-	16.5	V
High side floating supply voltage	V _{BS}	12.5	-	17.5	V
Input voltage (L _{IN} ,H _{IN} ,I _{TRIP} ,RFE)	V _{IN}	0	-	5	V
PWM carrier frequency	F _{PWM}	-	20	-	kHz
External dead time between H _{IN} & L _{IN}	DT	1	-	-	μs
Voltage between V _{SS} and N(U,V,W)	V _{COMP}	-5	-	5	V
Minimum input pulse width	PW _{IN(ON)} , PW _{IN(OFF)}	1	-	-	μs

6 Static Parameters

6.1 Inverter

$(V_{DD}-V_{SS}) = (V_B - V_S) = 15\text{ V}$. $T_C = 25^\circ\text{C}$ unless otherwise specified.

Table 8 IM241-L6 (B type)

Parameter	Symbol	Conditions	Min.	Typ.	Max.	Units
Collector-to-emitter saturation voltage	$V_{CE(sat)}$	$I_C = 1\text{ A}$	-	1.15	-	V
		$I_C = 2\text{ A}$	-	1.41	1.62	V
		$I_C = 2\text{ A}, T_J = 150^\circ\text{C}$	-	1.42	-	V
Collector emitter leakage current of high side IGBT	I_{LKH}	$V_{IN} = 0\text{ V}, V_+ = 600\text{ V}$	-	-	80	μA
		$V_{IN} = 0\text{ V}, V_+ = 600\text{ V}, T_J = 150^\circ\text{C}$	-	20.3	-	μA
Diode forward voltage	V_F	$I_C = 1\text{ A}$	-	1.20	-	V
		$I_C = 2\text{ A}$	-	1.42	1.65	V
		$I_C = 2\text{ A}, T_J = 150^\circ\text{C}$	-	1.40	-	V

6.2 Control

$(V_{DD}-V_{SS}) = (V_B - V_S) = 15\text{ V}$. $T_C = 25^\circ\text{C}$ unless otherwise specified. The V_{IN} and I_{IN} parameters are referenced to V_{SS} and are applicable to all six channels. The V_{DDUV} parameters are referenced to V_{SS} . The V_{BSUV} parameters are referenced to V_S .

Table 9

Parameter	Symbol	Min.	Typ.	Max.	Units
Logic "1" input voltage (LIN, HIN)	$V_{IN,TH+}$	2.2	-	-	V
Logic "0" input voltage (LIN, HIN)	$V_{IN,TH-}$	-	-	0.8	V
V_{DD}/V_{BS} supply undervoltage, positive going threshold	$V_{DD,UV+}, V_{BS,UV+}$	10.6	11.1	11.6	V
V_{DD}/V_{BS} supply undervoltage, negative going threshold	$V_{DD,UV-}, V_{BS,UV-}$	10.4	10.9	11.4	V
V_{DD}/V_{BS} supply undervoltage lock-out hysteresis	V_{DDUVH}, V_{BSUVH}	-	0.2	-	V
RFE positive going threshold	V_{RFE+}	-	1.9	2.2	V
RFE negative going threshold	V_{RFE-}	0.8	1.1	-	V
ITRIP positive going threshold	$V_{IT,TH+}$	0.475	0.500	0.525	V
ITRIP negative going threshold	$V_{IT,TH-}$	-	0.430	-	V
ITRIP input hysteresis	$V_{IT,HYS}$	-	0.07	-	V
Quiescent V_{BS} supply current	I_{QBS}	-	-	70	μA
Quiescent V_{DD} supply current per channel	I_{QDD}	-	-	3	mA
Input bias current $V_{IN}=5\text{ V}$ for LIN, HIN	I_{IN+}	-	6.25	12.5	μA
Input bias current $V_{IN}=5\text{ V}$ for RFE	$I_{IN,RFE+}$	-	-	1	μA

Static Parameters

Parameter	Symbol	Min.	Typ.	Max.	Units
Input bias current $V_{IN}=5V$ for ITRIP	I_{ITRIP+}	-	5	20	μA
Bootstrap resistance	R_{BS}	-	200	-	Ω
RFE low on resistance	R_{RFE}	-	34	60	Ω

7 Dynamic Parameters

7.1 Inverter

$(V_{DD} - V_{SS}) = (V_B - V_S) = 15\text{ V}$. $T_C = 25^\circ\text{C}$ unless otherwise specified.

Table 10 IM241-L6, B Type

Parameter	Symbol	Conditions	Min.	Typ.	Max.	Units
Input to output turn-on propagation delay	T_{ON}	$I_C = 2\text{ A}$, $V_+ = 300\text{ V}$	-	510	-	ns
Turn-on rise time	T_R		-	10.4	-	ns
Turn-on switching time	$T_{C(on)}$		-	61.7	-	ns
Input to output turn-off propagation delay	T_{OFF}	$I_C = 2\text{ A}$, $V_+ = 300\text{ V}$	-	711	-	ns
Turn-off fall time	T_F		-	106	-	ns
Turn-off switching time	$T_{C(off)}$		-	90.0	-	ns
RFE low to six switch turn-off propagation delay	T_{EN}	$V_{IN}=0$ or $V_{IN}=5\text{ V}$, $V_{RFE}=5\text{ V}$	-	430	-	ns
ITRIP to six switch turn-off propagation delay	T_{ITRIP}	$V_+ = 300\text{ V}$, no cap on RFE	-	1.3	-	μs
Turn-on slew rate	dV / dt	$I_C = 2\text{ A}$, $V_+ = 300\text{ V}$, $V_{DD} = 15\text{ V}$, $L = 5\text{ mH}$, mean of high side and low side	-	5.93	-	V/ns
Turn-on switching energy	E_{ON}	$I_C = 2\text{ A}$, $V_+ = 300\text{ V}$, $V_{DD} = 15\text{ V}$, $L = 6\text{ mH}$, mean of high side and low side	-	34.7	-	μJ
Turn-off switching energy	E_{OFF}		-	27.4	-	
Diode reverse recovery energy	E_{REC}		-	23.7	-	
Diode reverse recovery time	T_{RR}		-	93.5	-	ns
Turn-on switching energy	E_{ON}	$I_C = 2\text{ A}$, $V_+ = 300\text{ V}$, $V_{DD} = 15\text{ V}$, $L = 6\text{ mH}$ $T_J = 150^\circ\text{C}$, mean of high side and low side	-	72.2	-	μJ
Turn-off switching energy	E_{OFF}		-	42.5	-	
Diode reverse recovery energy	E_{REC}		-	51.2	-	
Diode reverse recovery time	T_{RR}		-	155	-	ns

7.2 Control

$(V_{DD} - V_{SS}) = (V_B - V_S) = 15\text{ V}$. $T_C = 25^\circ\text{C}$ unless otherwise specified.

Table 11

Parameter	Symbol	Conditions	Min.	Typ.	Max.	Units
Input filter time (HIN, LIN)	$T_{FIL,IN}$	$V_{IN} = 0$ or $V_{IN} = 5\text{ V}$	-	300	-	ns
Input filter time (ITRIP)	$T_{FIL,ITRIP}$	$V_{IN}=0$ or $V_{IN}=5\text{ V}$	-	500	-	ns
Internal dead time	DT_{IC}	$V_{IN} = 0$ or $V_{IN} = 5\text{ V}$	-	300	-	ns

Dynamic Parameters

Parameter	Symbol	Conditions	Min.	Typ.	Max.	Units
Matching propagation delay time (on and off) for same phase high-side and low-side	M_{τ}	External dead time > 500ns	-	-	50	ns

8 Thermistor Characteristics

Table 12

Parameter	Symbol	Conditions	Min.	Typ.	Max.	Units
Resistance	R_{25}	$T_C = 25^\circ\text{C}$, $\pm 5\%$ tolerance	44.65	47	49.35	$\text{k}\Omega$
Resistance	R_{125}	$T_C = 125^\circ\text{C}$	1.27	1.39	1.51	$\text{k}\Omega$
B-constant (25/100)	B	$\pm 1\%$ tolerance	-	4006	-	K
Temperature Range			-20	-	150	$^\circ\text{C}$

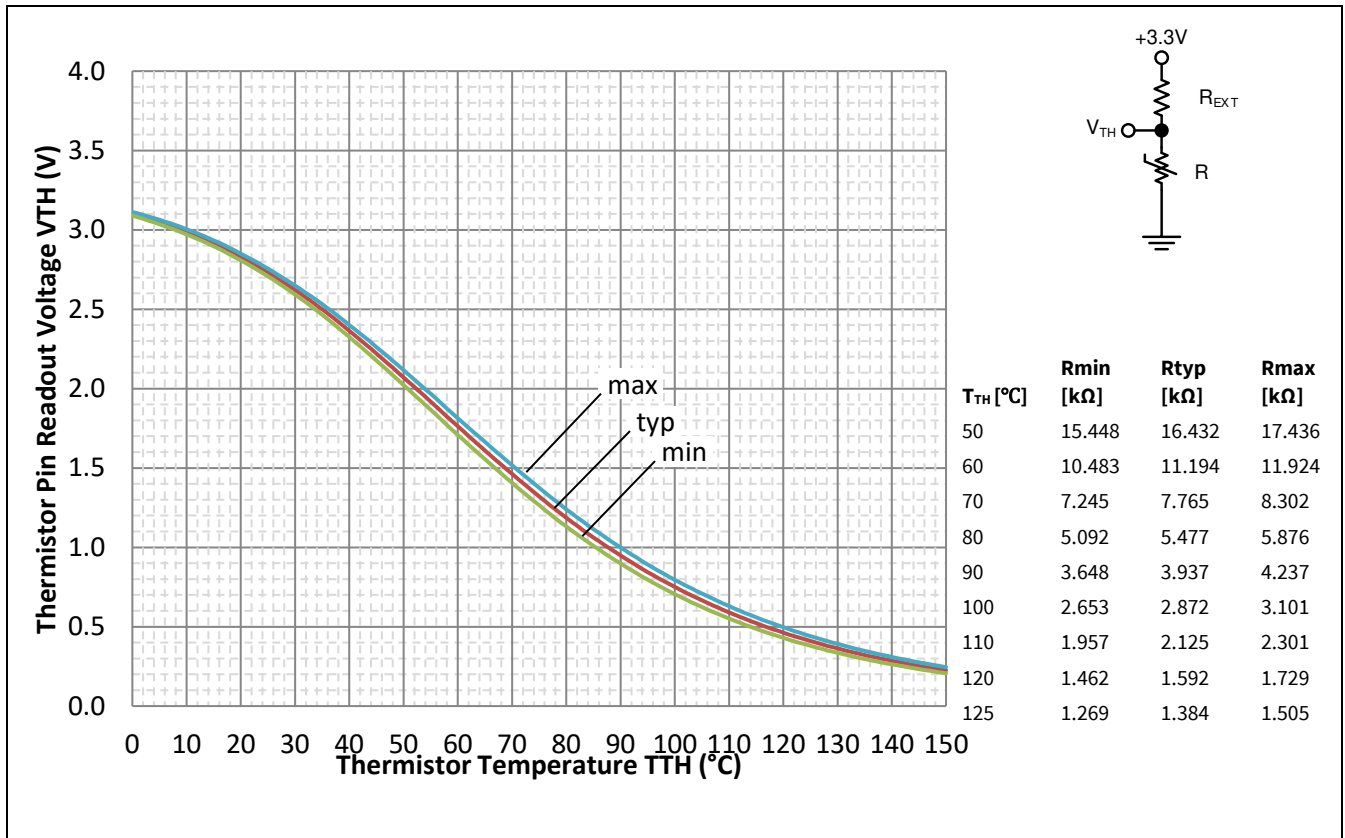

Figure 7 Thermistor resistance - temperature curve, for $R_{EXT}=9.76\text{k}\Omega$, and thermistor resistance variation with temperature.

9 Mechanical Characteristics and Ratings

Table 13

Parameter	Symbol	Conditions	Min.	Typ.	Max.	Units
Comparative Tracking Index	CTI		550	-	-	V
Curvature of module backside	BC	See Figure 9	-50	-	50	μm
Mounting Torque	T	M3 screw & washer, thermal grease	0.4	0.8	1.2	Nm
		M3 screw & washer, SIL-PAD 1500ST	-	0.6	1.0	Nm
Weight	W		-	3	-	g

10 Qualification Information

Table 14

UL Certification	UL-US-L252584-15-22508102-2	
Moisture sensitivity level (SOP 29 x 12 only)	MSL3	
RoHS Compliant	Yes	
ESD	Human body model	1C
	Charge discharge model	C3

11 Diagrams & Tables

11.1 T_c Measurement Point

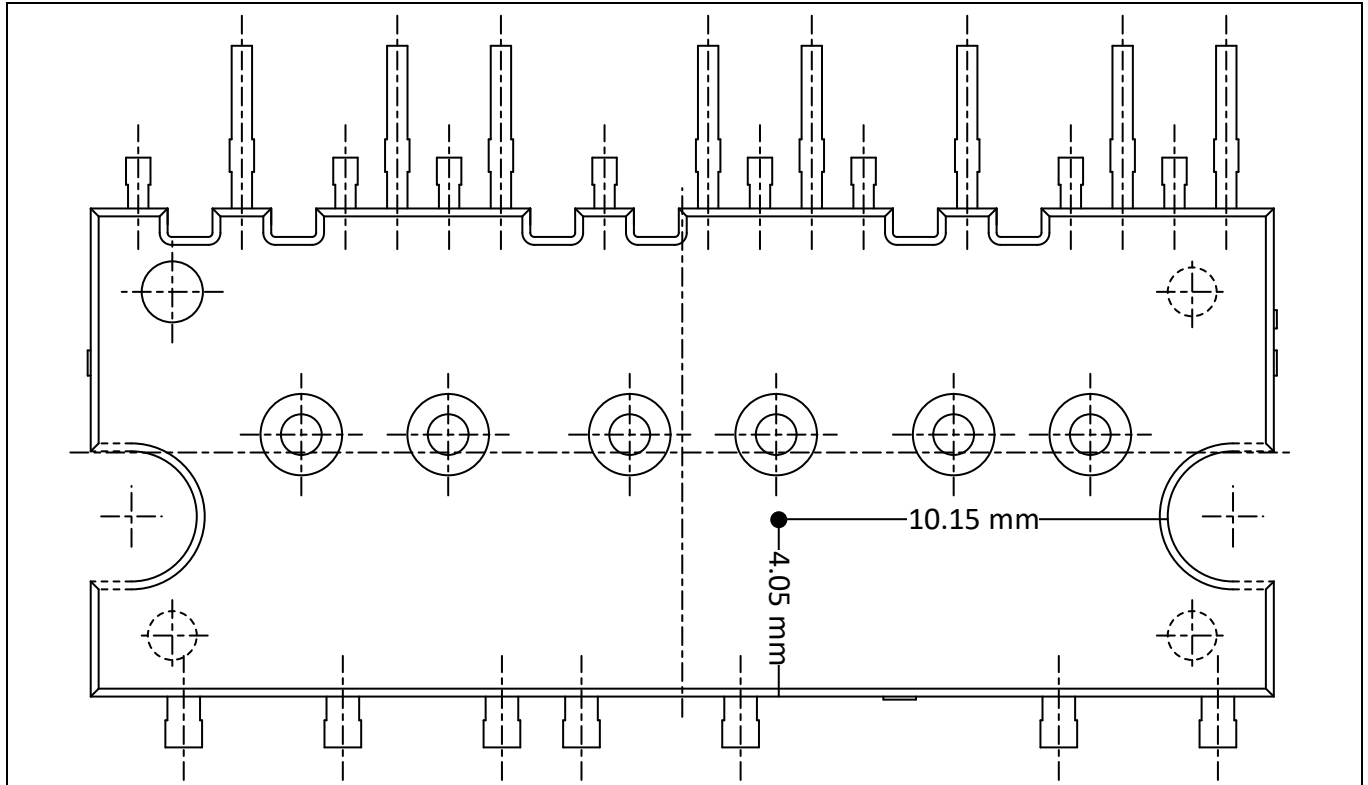

Figure 8 T_c measurement point

11.2 Backside Curvature Measurement Points

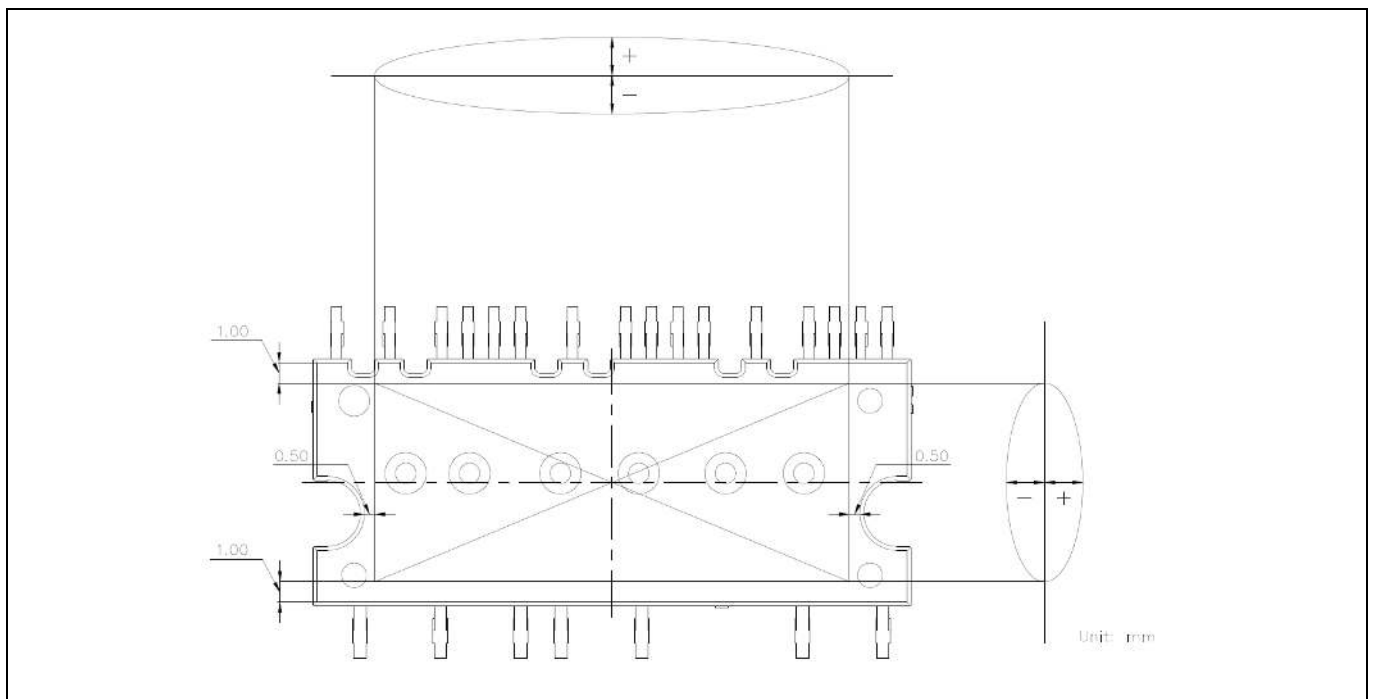

Figure 9 Curvature measurement points

11.3 Input-Output Logic Table

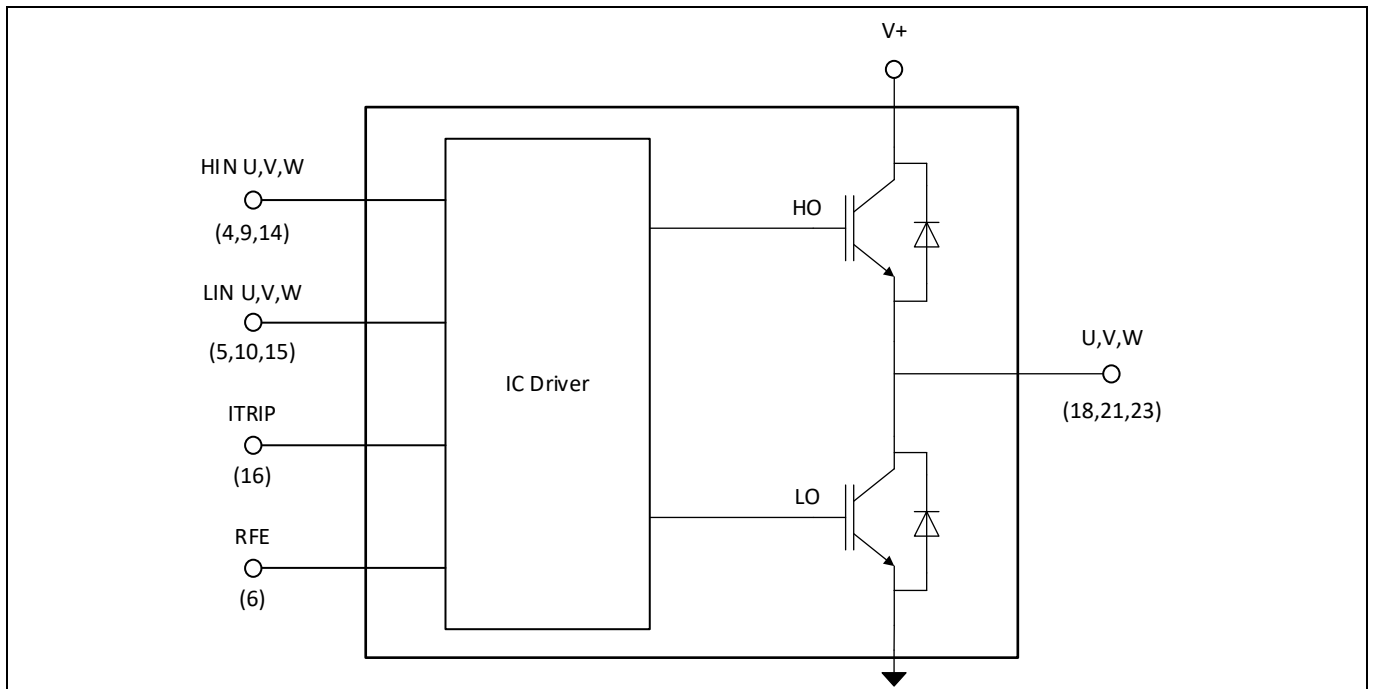

Figure 10 Module block diagram

Table 15

RFE	ITRIP	HIN U,V,W	LIN U,V,W	U,V,W
1	0	1	0	V+
1	0	0	1	0
1	0	0	0	‡
1	0	1	1	‡
1	1	x	x	‡
0	x	x	x	‡

‡ Voltage depends on direction of phase current

11.4 Switching Time Definitions

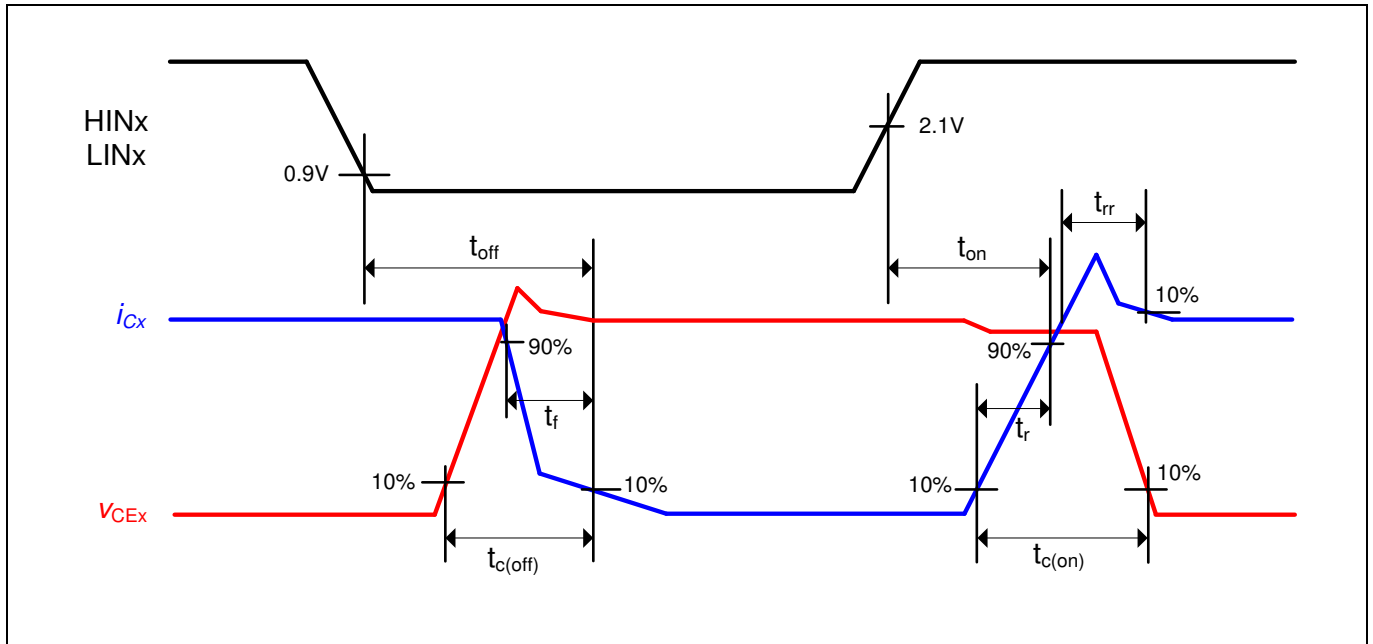

Figure 11 Switching times definition

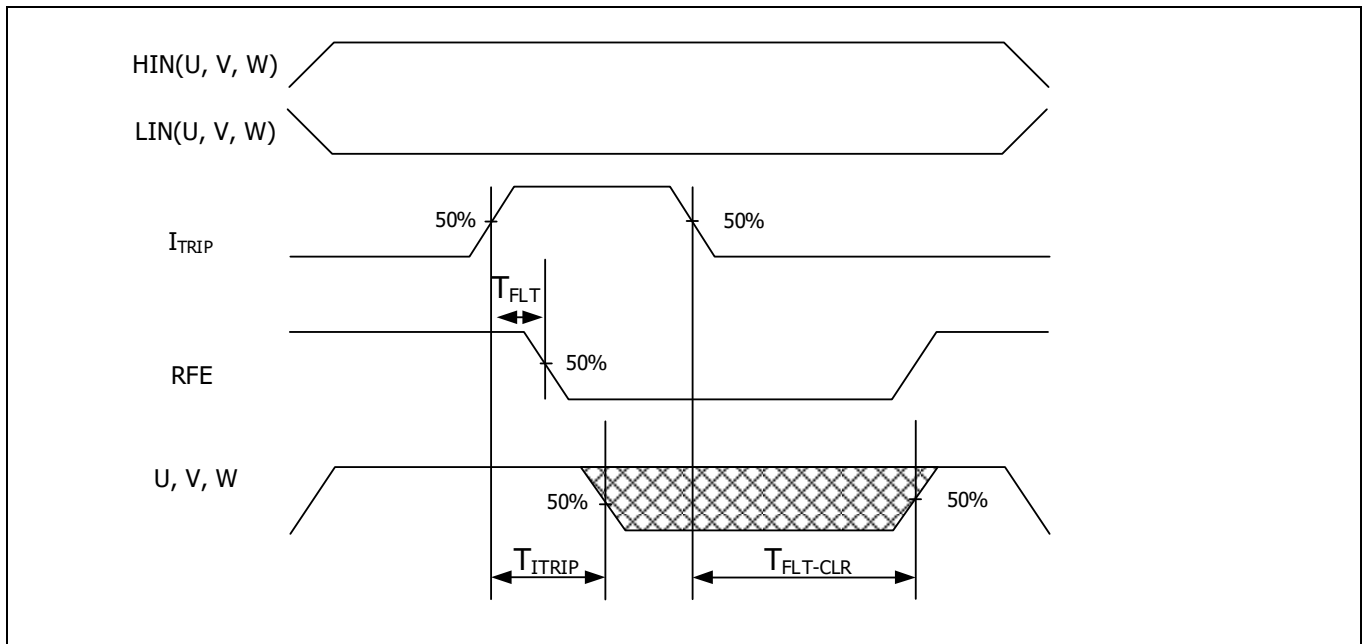

Figure 12 ITRIP time waveform

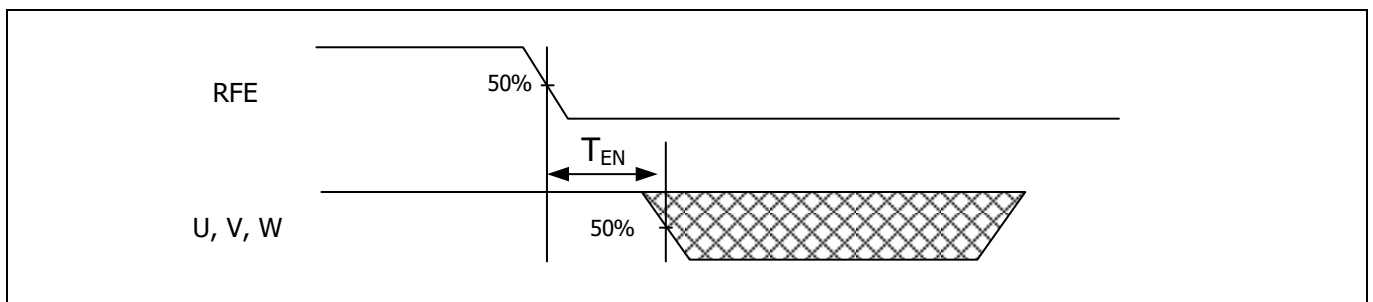

Figure 13 Output disable timing diagram

12 Application Guide

12.1 Typical Application Schematic

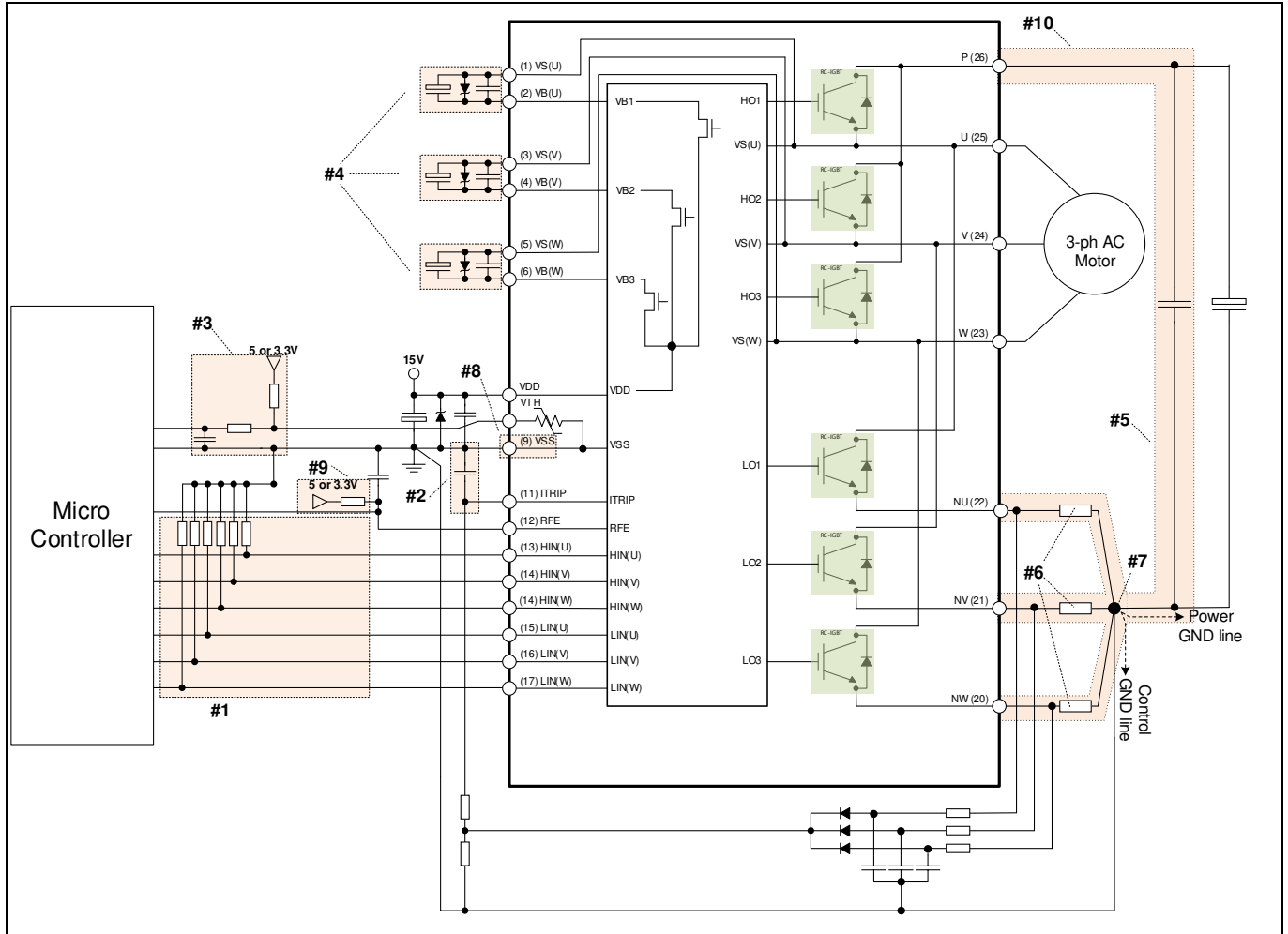

Figure 14 Application schematic

12.2 T_J vs T_{TH}

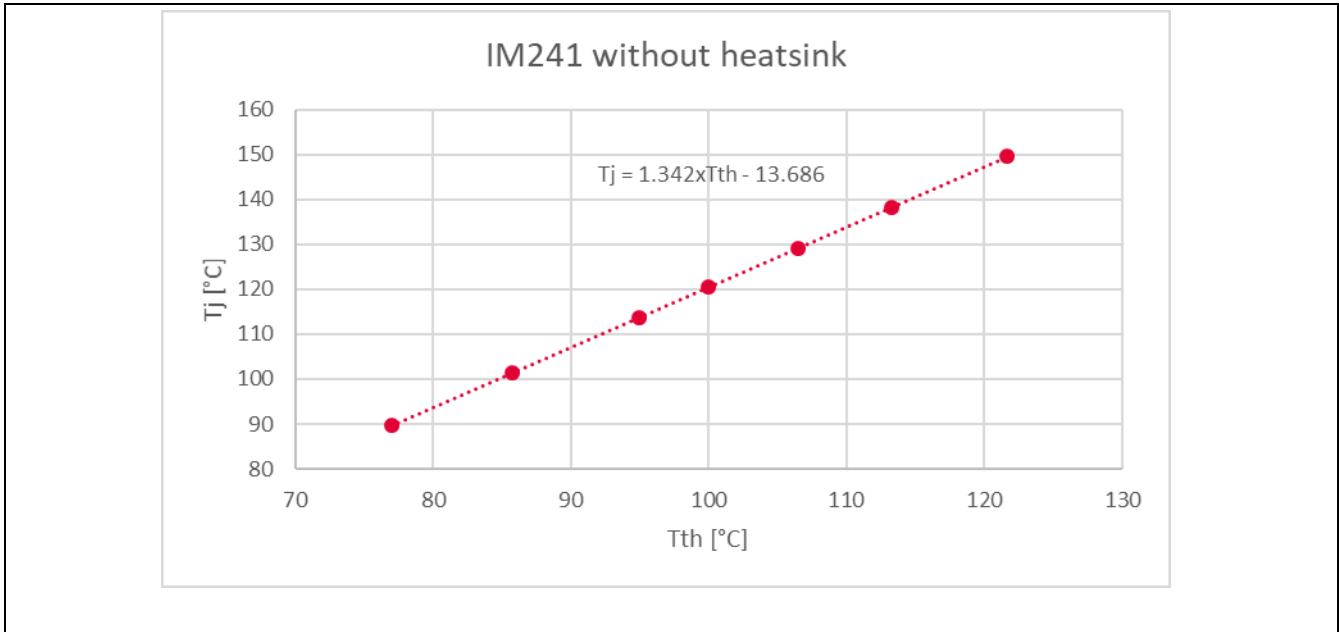

Figure 15 Typical T_J vs T_{TH} correlation without heatsink (AN-2021-08 for reference)

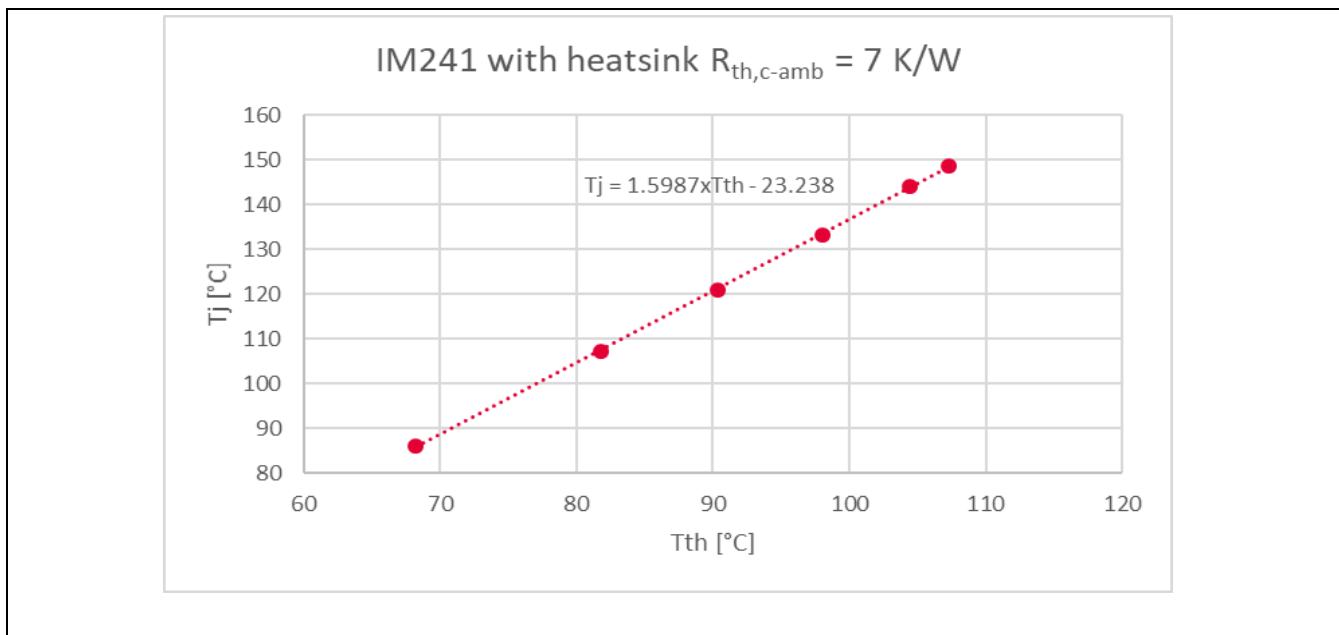

Figure 16 Typical T_J vs T_{TH} correlation with heatsink and $R_{th,c-amb} = 7 \text{ K/W}$ (AN-2021-08 for reference)

12.3 -V_s Immunity

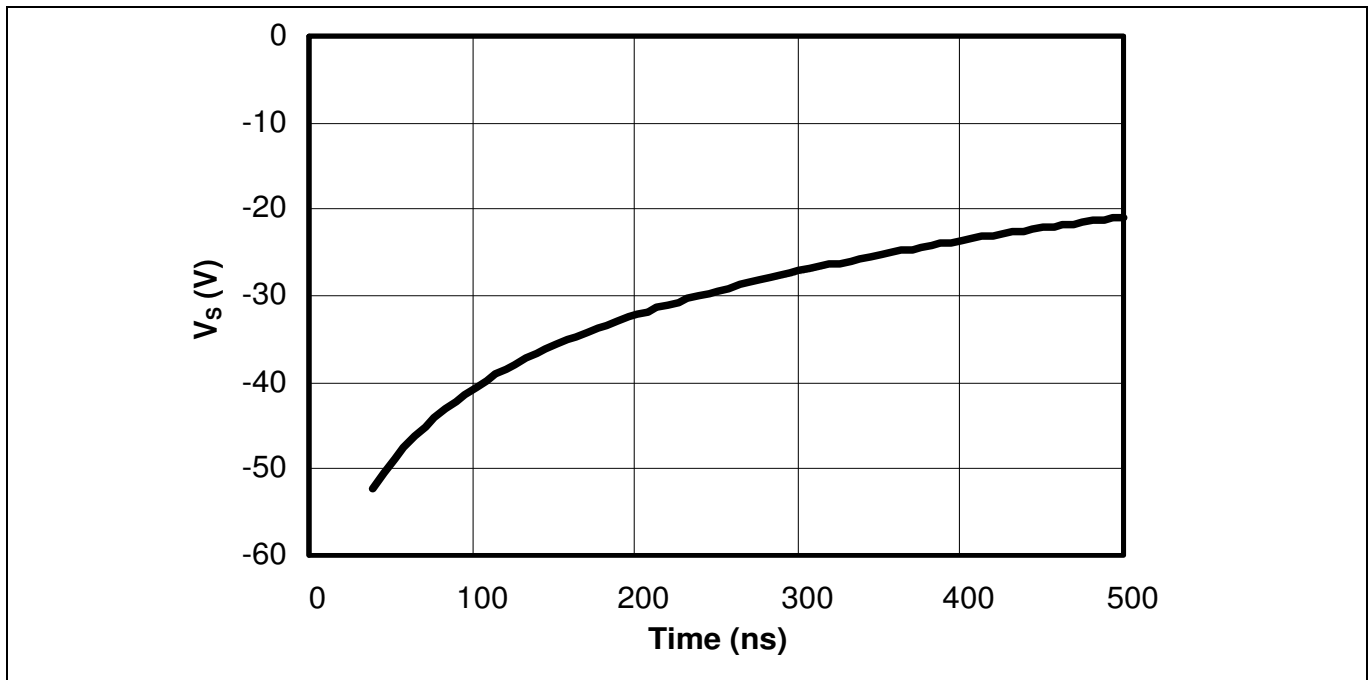
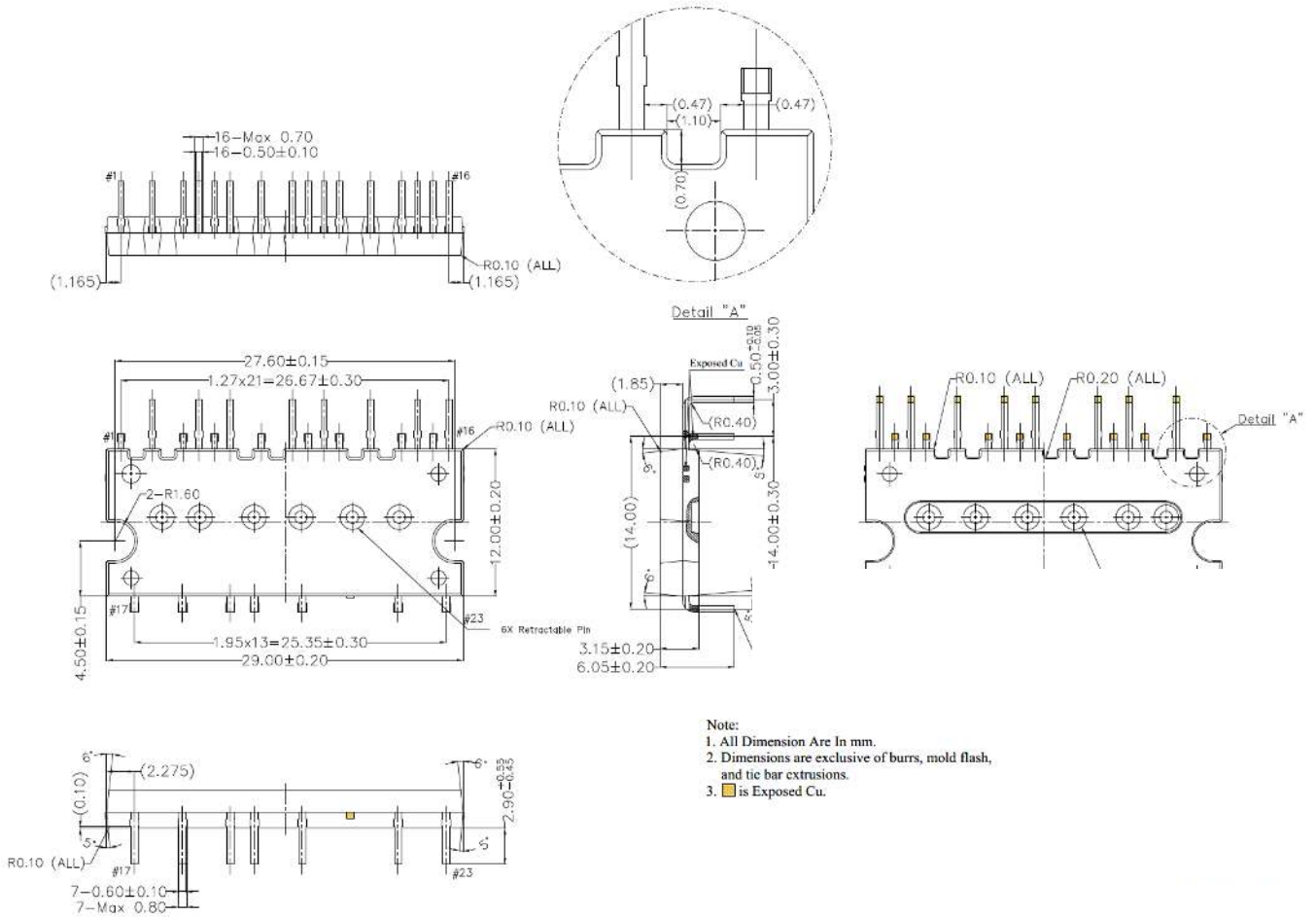

Figure 17 Negative transient V_s SOA for integrated gate driver

13 Package Outline

13.1 DIP 29x12



Dimensions in mm

13.2 SOP 29x12

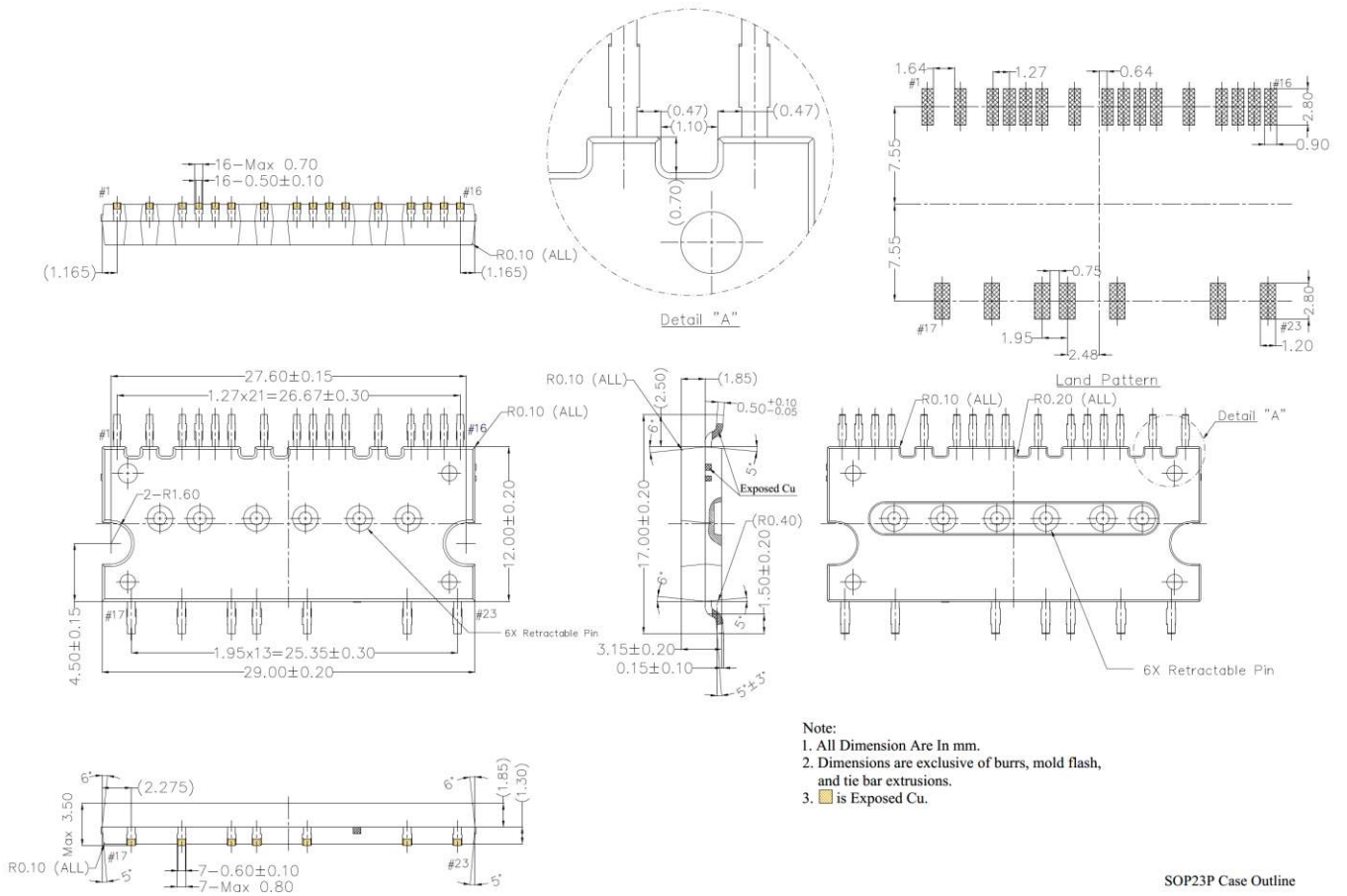

SOP23P Case Outline

Dimensions in mm

14 Revision History

Major changes since the last revision

Page or Reference	Description of change

Trademarks

All referenced product or service names and trademarks are the property of their respective owners.

Edition 2022-06-26

Published by

Infineon Technologies AG

81726 München, Germany

© 2022 Infineon Technologies AG.

All Rights Reserved.

Do you have a question about this document?

Email: erratum@infineon.com

Document reference

IMPORTANT NOTICE

The information given in this document shall in no event be regarded as a guarantee of conditions or characteristics ("Beschaffheitsgarantie").

With respect to any examples, hints or any typical values stated herein and/or any information regarding the application of the product, Infineon Technologies hereby disclaims any and all warranties and liabilities of any kind, including without limitation warranties of non-infringement of intellectual property rights of any third party.

In addition, any information given in this document is subject to customer's compliance with its obligations stated in this document and any applicable legal requirements, norms and standards concerning customer's products and any use of the product of Infineon Technologies in customer's applications.

The data contained in this document is exclusively intended for technically trained staff. It is the responsibility of customer's technical departments to evaluate the suitability of the product for the intended application and the completeness of the product information given in this document with respect to such application.

For further information on the product, technology, delivery terms and conditions and prices please contact your nearest Infineon Technologies office (www.infineon.com).

WARNINGS

Due to technical requirements products may contain dangerous substances. For information on the types in question please contact your nearest Infineon Technologies office.

Except as otherwise explicitly approved by Infineon Technologies in a written document signed by authorized representatives of Infineon Technologies, Infineon Technologies' products may not be used in any applications where a failure of the product or any consequences of the use thereof can reasonably be expected to result in personal injury.