

ADS58J89 Evaluation Module

This document outlines the basic steps and functions that are required to ensure the proper operation of the Texas Instruments (TI) ADS58J89 Evaluation Module (EVM). The EVM includes an ADS58J89EVM, a cable for connection to an external 5-VDC power supply, and a mini-USB cable. This EVM is designed to be used with the TI TSW14J56EVM JESD204B capture card using a FMC connector interface or FPGA development boards, such as the Xilinx KC705 or Altera Arria V. The ADS58J89EVM contains an ADS58J89 (14-bit) four-channel, 500-MSPS front-end receiver IC. The EVM also contains a TI LMK04828 clock jitter cleaner. When used with the TSW14J56EVM, JESD204B standard output data from the EVM is captured and sent to a host PC for analysis. This guide helps users to quickly evaluate the performance of the ADS58J89EVM board by capturing and displaying waveforms using the TSW14J56 with the High Speed Data Converter Pro GUI software. The EVM schematics, BOMs, and layout files are found in the design package under the ADS58J89EVM product folder on www.ti.com.

Contents

1	Introduction	2
	1.1 Overview	2
	1.2 Block Diagram.....	2
2	Software Control	4
	2.1 Installation Instructions.....	4
	2.2 Software Operation	4
3	Basic Test Setup	16
	3.1 Test Block Diagram	16
	3.2 TSW14J56EVM Setup.....	17
	3.3 ADS58J89EVM Quick-Start Procedure	17

List of Figures

1	Block Diagram of the ADS58J89EVM	2
2	Top-Level Block Diagram Window of the ADS58J89 GUI.....	5
3	ADS58J89 Controls Tab	6
4	Trigger Configuration Controls Tab.....	7
5	JESD204B Configuration Tab.....	9
6	LMK04828 PLL1 Configuration Tab	10
7	LMK04828 PLL2 Configuration Tab	11
8	LMK04828 Clock Outputs Tab	12
9	LMK04828 SYSREF and SYNC tab.....	13
10	Low Level Controls Tab	15
11	Test Setup.....	16
12	High Speed Data Converter Pro (HSDCPro) Sample Capture.....	19

List of Tables

1	Input and Output Connectors and Jumper Descriptions of the ADS58J89EVM.....	3
2	ADS58J89 Controls Tab Descriptions	6
3	Trigger Configuration Controls Descriptions	8

1 Introduction

1.1 Overview

The ADS58J89EVM is an evaluation module (EVM) used to evaluate Texas Instruments' ADS58J89 front-end receiver IC and the LMK04828 clock jitter cleaner devices. The ADS58J89 (14-bit) is a four-channel, 500-MSPS front-end receiver IC with buffered analog inputs and outputs featuring a JESD204B interface. The EVM has transformer-coupled analog inputs accommodating a wide range of signal sources and frequencies. The LMK04828 provides an ultra-low-jitter and phase-noise sample clock along with system reference clocks and a device sample clock for the mating FPGA capture board, for a complete JESD204B subclass 1 clocking solution.

The ADS58J89 and LMK04828 are controlled through an easy-to-use software GUI enabling quick configuration for a variety of uses.

The TSW14J56EVM connects directly to the ADS58J89EVM. The High Speed Data Converter Pro software GUI processes the data from the TSW14J56EVM to quickly assess the performance of the ADS58J89. The FMC output interface connector of the EVM has also been verified to be compatible with both the Xilinx KC705 and Altera Arria V evaluation platforms.

1.2 Block Diagram

The block diagram for the ADS58J89EVM is shown in [Figure 1](#). The various inputs, outputs, and jumpers of the ADS58J89EVM are described in [Table 1](#).

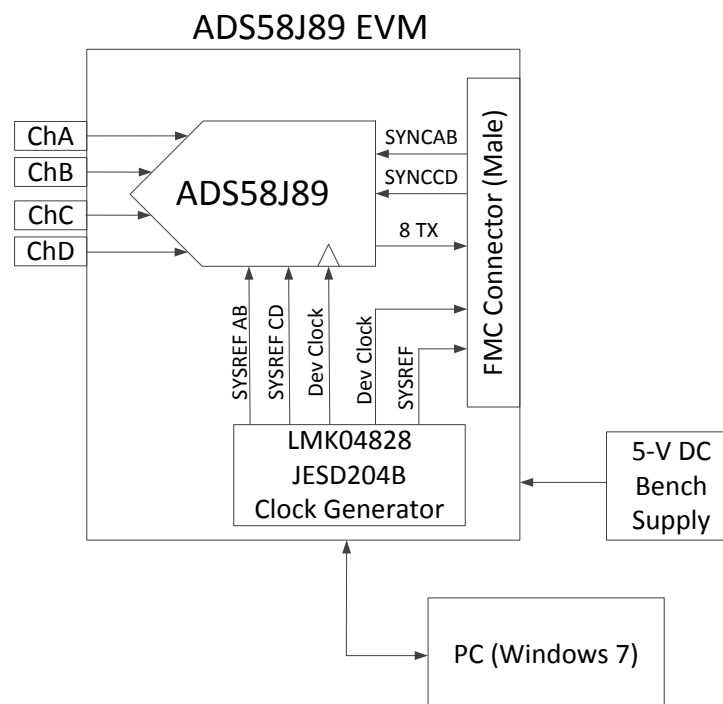

Figure 1. Block Diagram of the ADS58J89EVM

Table 1. Input and Output Connectors and Jumper Descriptions of the ADS58J89EVM

Component	Description
J1 (AINP)	Analog input for channel A, single-ended or positive side of differential. (Negative side of differential on J11, normally not installed.)
J2 (BINP)	Analog input for channel B, single-ended or positive side of differential. (Negative side of differential on J12, normally not installed.)
J23 (CINP)	Analog input for channel C, single-ended or positive side of differential. (Negative side of differential on J25, normally not installed.)
J22 (DINP)	Analog input for channel D, single-ended or positive side of differential. (Negative side of differential on J24, normally not installed.)
J19 (EXT_ADC_CLK)	Single-ended ADC clock input
J20 DCLK	Optional device clock output, single-ended transformer coupled
J8 (+5V)	Positive power connection (5 V)
J9 (GND)	Negative power connection (GND)
J13 (Main PWR)	5-V input from +5-V bench supply (cable supplied)
J14 (REF_OSC_IN)	External reference option for LMK04828, REFOUT1 source on J16 and CPLD_CLK
J16 (REFOUT1)	10-MHz CMOS level reference output or frequency of REF_OSC_IN if option selected
J6 (USB)	USB connection
J3	JESD204B FMC interface connector
J5 (TRIG_IN)	External trigger input for ADS58J89 burst mode
J26 (TRIG_OUT)	Trigger output, buffered version of ADS58J89 burst mode trigger, normally connected to trigger input of TSW14J56 capture card
J7 (LMK_CLKIN1_P)	CLKIN0 input for LMK04828. Option to provide an external clock source to the LMK in place of on-board 100-MHz VCXO.
J10 (CLKOUT6P)	DCLKOUT6p from LMK04828. Default is LVPECL at 250 MHz.
J15 (CLKOUT6N)	DCLKOUT6n from LMK04828. Default is LVPECL at 250 MHz.
J17 (CLKOUT7P)	SDCLKOUT7p from LMK04828. Default is LVPECL at 6.25 MHz.
J4 (CLKOUT7M)	SDCLKOUT7p from LMK04828. Default is LVPECL at 6.25 MHz.
J18 (PROG_CPLD)	JTAG interface for CPLD U3
SW1 (ADC_RESET)	Switch to reset the ADC using the RESET input pin
SW2 (TRIGGER)	Pushbutton trigger source for ADS58J89 burst mode
JP6 (XO_PWR)	Provides power to VCXO Y2 or oscillator Y3
SJP3 (REF_SEL)	Selects input or external reference source for LMK, J16 and CPLD. Default is internal (on-board) 10-MHz oscillator.
JP2 (CDC_CLK)	Reference clock buffer output enable
JP5 (REF_PWR)	Power enable for 10-MHz reference oscillator
SJP1 (REF_EN)	Enable for 10-MHz reference oscillator
SJP4-SJP11	USB/FMC Interface select. Default is using USB.
JP4 (ENABLE)	U11 enable. Install jumper to disable switcher U11. Default is uninstalled.
JP1 (PWRGD)	Test point for power good output pin from U11.

2 Software Control

This section provides installation instructions for the ADS58J89 GUI and descriptions of the various controls.

2.1 Installation Instructions

1. Download the software from the ADS58J89EVM resource page:
<http://www.ti.com/ww/en/analog/dataconverters/jesd204b/resources.shtml>.
2. Extract the files from the zip file named *ADS58J8x GUI vXpY installer.zip* where *XpY* represents the version number.
3. Run *setup.exe* and follow the installation prompts.
4. Start the GUI by going to **Start Menu** → **All Programs** → **Texas Instruments ADCs** → **ADS58J89 EVM GUI**.
5. When plugging the board into the computer for the first time through the USB cable, you are prompted to install the USB drivers.
 - Microsoft® Windows® XP: If Windows XP does not automatically install the drivers, follow the prompts on the screen to do so. Do not let Windows XP search Microsoft Update for the drivers, but do let Windows XP install the drivers automatically.
 - Windows 7: After installing the GUI, Windows 7 should automatically be able to install the drivers for the ADS58J89EVM with no user input.

2.2 Software Operation

The software GUI allows full programming control of the ADS58J89 and LMK04828 devices. [Figure 2](#) shows the GUI front panel which contains a block diagram of the ADS58J89. Clicking on the various tabs of the ADS58J89 EVM SPI GUI allows configuration of the settings contained within that tab. Detailed descriptions for each tab of the GUI are given in this section. Please refer to the ADS58J89 data sheet ([SBAS659](#)) for more detailed explanations of the register fields.

2.2.1 Top Level GUI Controls

Figure 2 shows the top-level view of the GUI which contains the block diagram of the ADS58J89. Controls for the ADS58J89 are under the ADS58J89 tab while controls for the LMK04828 are under the LMK04828 tab. The low level tab allows detailed bit-level access to all SPI registers of both the ADS58J89 and LMK04828. At all times the status of the USB link between the PC and the EVM is indicated by an LED indicator. A green indicator means the USB link is active. A red LED indicates the USB link must be reset. The Reconnect FTDI button will attempt to reestablish the USB link between the PC and the EVM. For the GUI to operate correctly it is important that the ADS58J89 and LMK04828 each be reset by clicking on the respective reset control. The reset control will reset all the internal SPI registers to their default power-on state, and then set the device in 4-wire SPI mode of operation. The USB interface on the EVM requires the ADS58J89 and LMK04828 to be in 4-wire SPI mode for the SPI readback function to work. If power is disrupted to the EVM at any time, a reset for each device will be required.

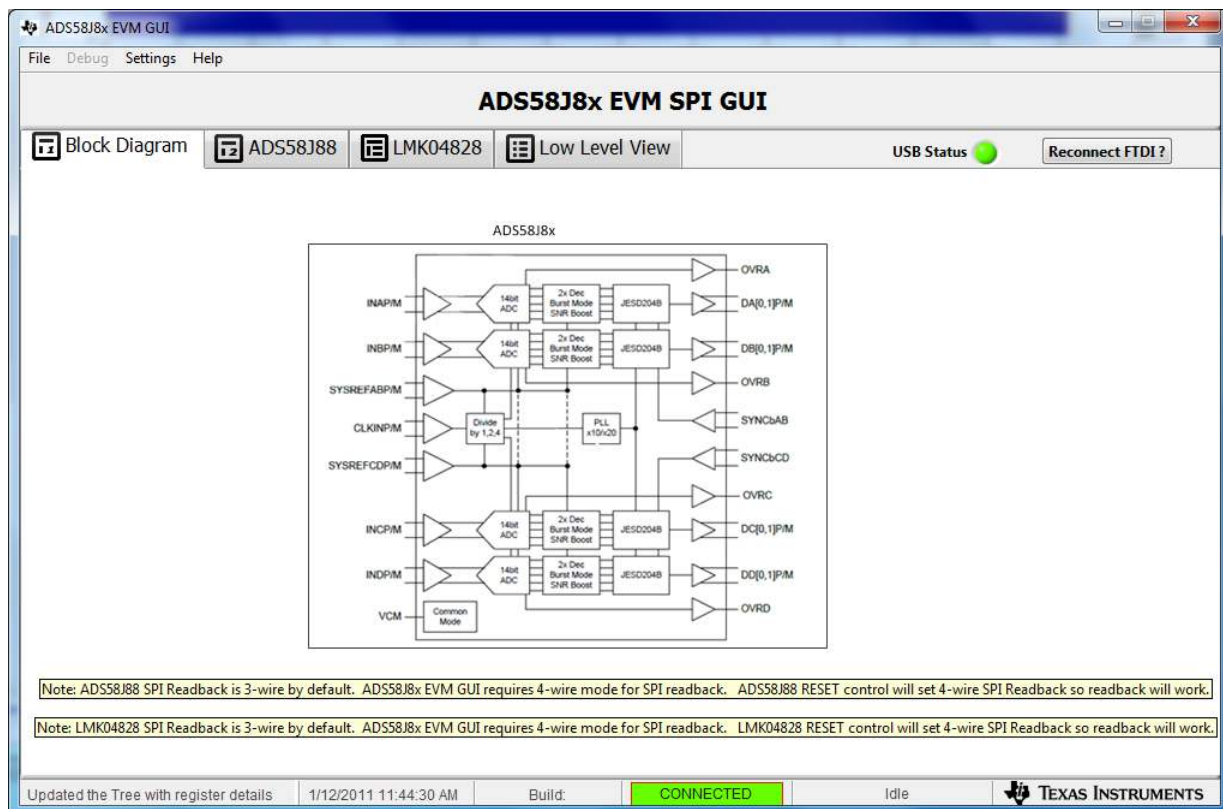

Figure 2. Top-Level Block Diagram Window of the ADS58J89 GUI

2.2.2 ADC Controls

Clicking on the *ADS58J89* tab in [Figure 2](#) takes the user to a bank of tabs for control of the *ADS58J89*, one of which is the *ADC Controls* tab, as shown in [Figure 3](#). The *ADC Controls* tab controls various ADC functions such as the over-range detection, test patterns, output modes, input clocking modes, and power down controls. [Table 2](#) describes the controls seen in this window. The higher level tabs remain visible at all times so that the user may quickly move to controls for the *LMK04828* or to low level register controls.

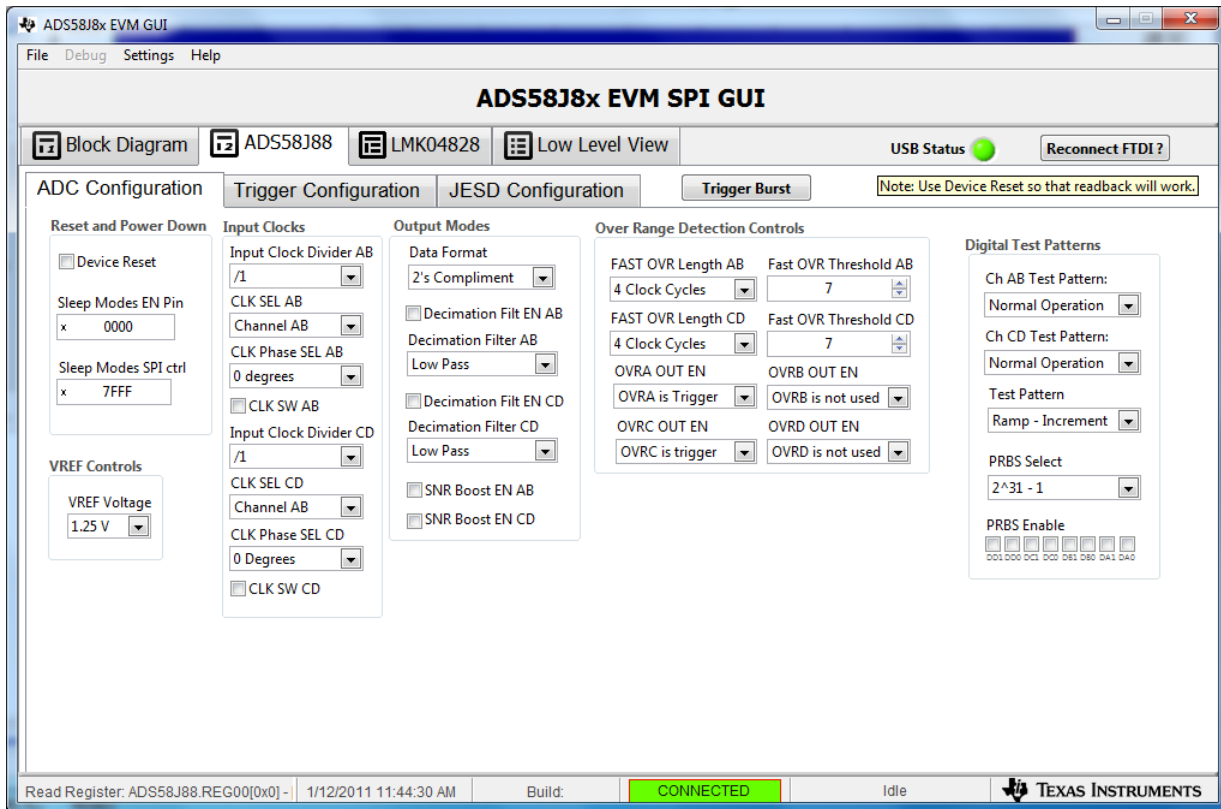

Figure 3. *ADS58J89* Controls Tab

Table 2. *ADS58J89* Controls Tab Descriptions

Control	Description
Device Reset	Resets the <i>ADS58J89</i> SPI registers and sets the device in 4-wire SPI mode
VREF Voltage	Selects the reference voltage and thus the full scale voltage
Input Clock Divider AB and CD	Selects an input divider of /1, /2 or /4 for channels A and B or channels C and D respectively
CLK SEL AB and CD	Selects the clock input for channels A and B or for channels C and D respectively
CLK Phase SEL AB and CD	Selects the phase relationship of the clock input for channels A and B or for channels C and D respectively
CLK SW AB and CD	Used in conjunction with changing the clock phase relationship of channels A and B or channels C and D.
Data Format	Selects offset binary or two's complement data format
Decimation Filter EN AB and CD	Enables the decimation filter for channels A and B or channels C and D
Decimation Filter AB and CD	Selects whether the decimation filter will be high-pass or low-pass
SNRBoost EN AB and CD	Enables the SNRBoost function for channels A and B or channels C and D

Table 2. ADS58J89 Controls Tab Descriptions (continued)

Control	Description
Fast OVR Length AB and CD	Selects how long the OVR output is active upon overrange detection
Fast OVR Threshold AB and CD	Sets how close to full scale the input can be before the fast overrange will detect overrange
OVRx OUT EN	Selects the function of the fast OVR pin for each of the four channels
Ch AB and CD Test Pattern	Selects an output test pattern or normal sample data for channels A and B or channels C and D
Test Pattern	Selects the specific test pattern to be output when test pattern is selected
PRBS Select	Selects the length of the PRBS test pattern
PRBS Enable	Selects the PRBS test pattern to be output on individual serial lane outputs

2.2.3 Trigger Configuration Controls

Clicking *Trigger Configuration* brings up the *Trigger Configuration* controls tab, shown in [Figure 4](#). Trigger controls for channels A and B are shown on the left side of the window and similar controls for channels C and D are shown on the right side of the window. All of the controls on this tab are only useful if the device is used in burst mode. In burst mode, the ADS58J89 outputs low resolution data until a trigger event is presented to the device at which time the device begins to output 14 bit resolution data for a programmable period of time. Then the device switches back to low resolution output for a minimum different programmable period of time. The low-resolution output must be long enough that the duty cycle of low resolution to high resolution output is above a certain minimum threshold. LED-style indicators on the tab indicate whether the programmed length of time for high resolution and low resolution meet the duty cycle requirements. Descriptions for the various controls are given in [Table 3](#).

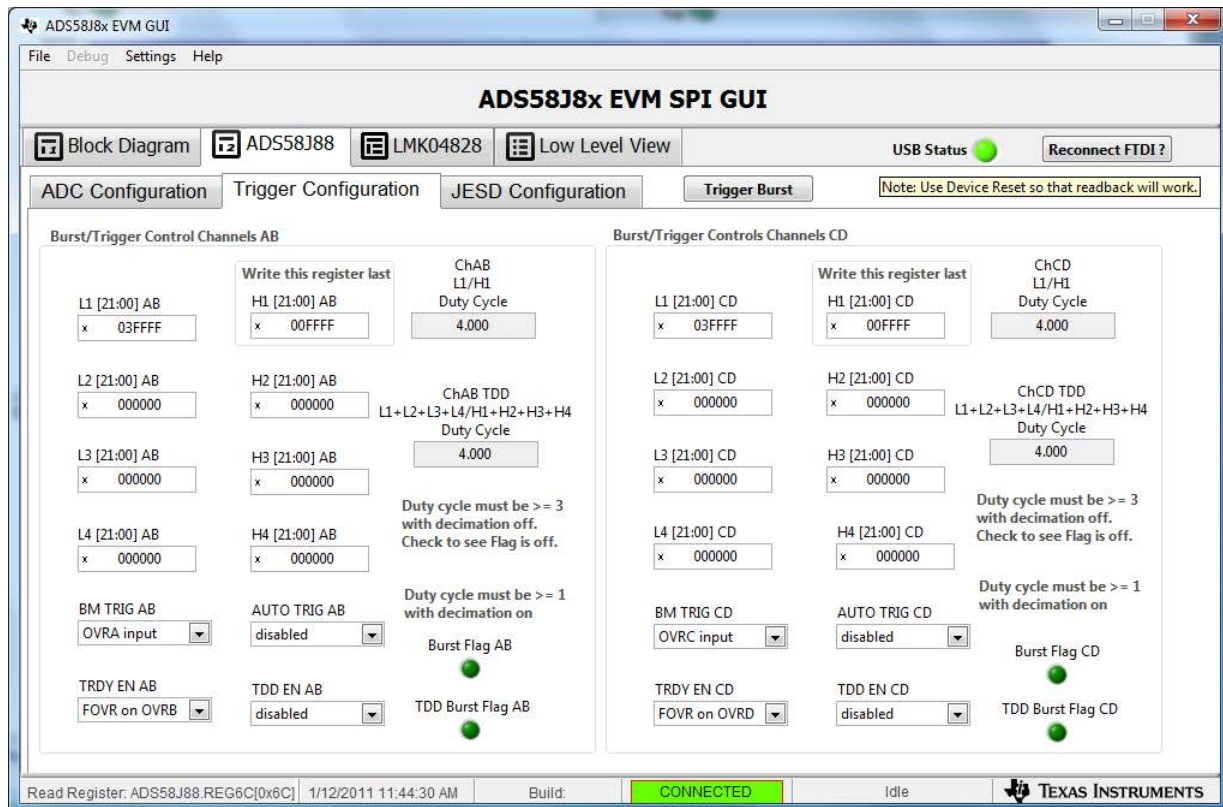

Figure 4. Trigger Configuration Controls Tab

Table 3. Trigger Configuration Controls Descriptions

Control	Description
BM TRIG	Selects the input pins that the Burst Mode Trigger will be input on for channels A and B or channels C and D
TRDY EN	Selects how to output the indication that the device is ready for the next trigger for channels A and B or channels C and D
AUTO TRIG	Selects whether to automatically start outputting high resolution data after the expiration of the programmed low resolution data for channels A and B or channels C and D
TDD EN	Selects whether the four counters each of low resolution and high resolution data are used for TDD burst mode, or whether just the L1 and H1 counters are used for normal burst mode
L1, L2, L3, L4	Burst Mode counters to set the length of the low resolution output for channels A and B or channels C and D
H1, H2, H3, H4	Burst Mode counters to set the length of the high resolution output for channels A and B or channels C and D. It is after the H1 counter is set then the device computes the duty cycle and compares if the duty cycle meets the threshold requirements and the Burst Flag indicators are updated.
L1/H1 Duty Cycle	Computes and displays the duty cycle of the values programmed into L1 and H1 (Not an input control)
L1+L2+L3+L4/H1+H2+H3+H4 Duty Cycle	Computes and displays the TDD duty cycle of the values programmed into all the counter registers (Not an input control)

2.2.4 JESD204B Controls

Clicking on JESD204B Configuration opens the *JESD204B Configuration* controls tab, shown in [Figure 5](#). Use the ADS58J89 data sheet ([SLAS659](#)) for reference to assist with the descriptions of these various controls. The ADS58J89 EVM SPI GUI comes with a number of configuration files that will set the EVM into a known and tested configuration that works with the TSW14J56 capture card. Full control of the JESD204B configuration is possible with the use of this tab of controls. Of primary importance are the JESD204B parameters L, M, F, and K. The parameter M refers to the number of data converters in a JESD204B link, and since the ADS58J89 is a four channel device then M is assumed to be 4. The parameter L refers to the number of lanes used. The ADS58J89 may use one lane per channel when in 2x decimation mode to output 250MSPS or use 2 lanes per channel when outputting sample data at 500MSPS. L may then be either 4 or 8. The parameter F is the number of octets (an octet is half of a sample transmitted per lane). The parameter K is a number of 'frames' of sample data bundled into a multiframe of length K frames, and this sets the period of the SYSREF clock signal. The TSW14J56 capture card (or other FPGA receiving JESD204B serial sample data from the EVM) must be configured with the same parameters as the ADS58J89.

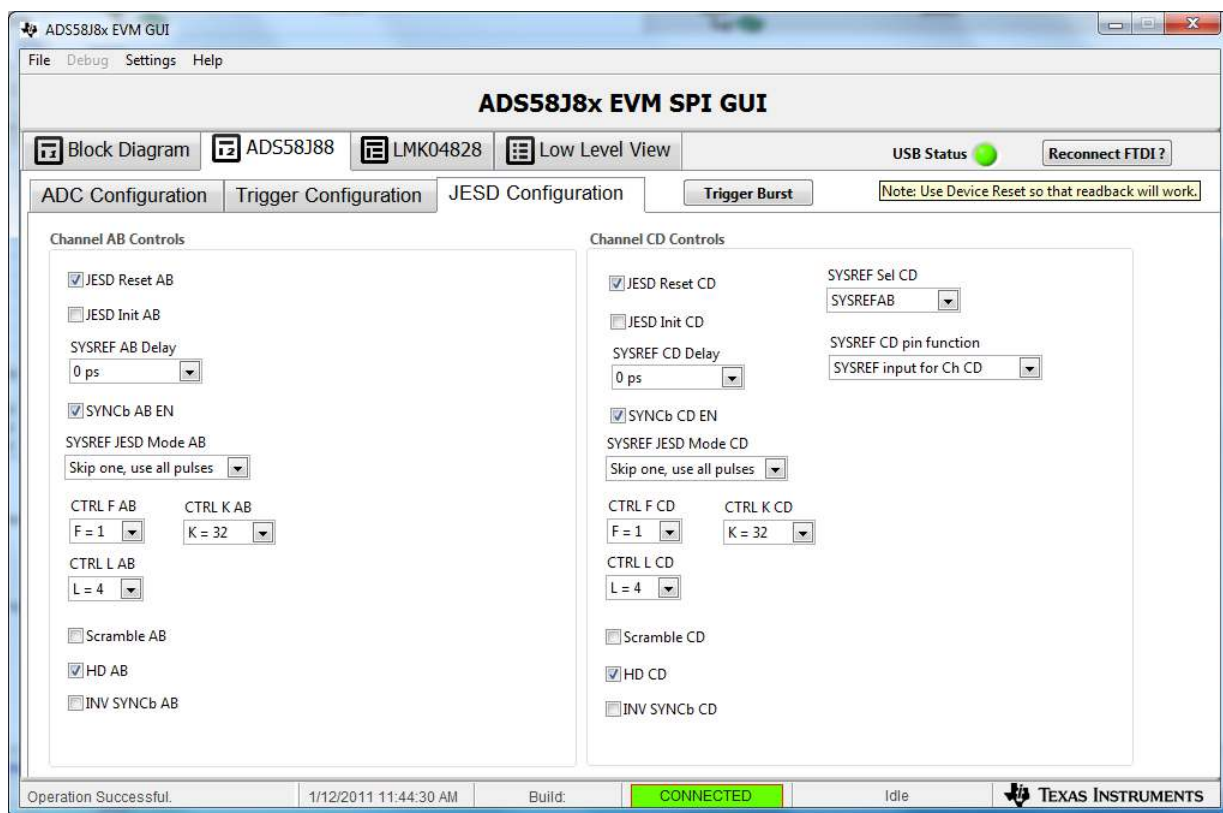

Figure 5. JESD204B Configuration Tab

2.2.5 LMK Controls

Click the *LMK04828* tab located in the top tab bar of the GUI. The bank of LMK04828 control tabs is selected as shown in Figure 6. There are four lower level tabs for control of the LMK04828. The LMK04828 is a dual-PLL clock device so there is a tab for setting controls for the first PLL and a tab for setting controls of the second PLL. There is a tab for setting controls related to the programming of the JESD204b SYSREF and SYNC signals. There is a tab for individual control of each of the 14 clock outputs of the LMK04828. The first PLL is represented in the PLL1 Configuration tab. The first PLL essentially takes a low-frequency reference and multiplies this up to an internal reference frequency. The second PLL has a very clean narrow-bandwidth VCO of either 2.5 or 3.0 GHz that is locked to the internal reference frequency from PLL1 and from this VCO the output clocks are generated.

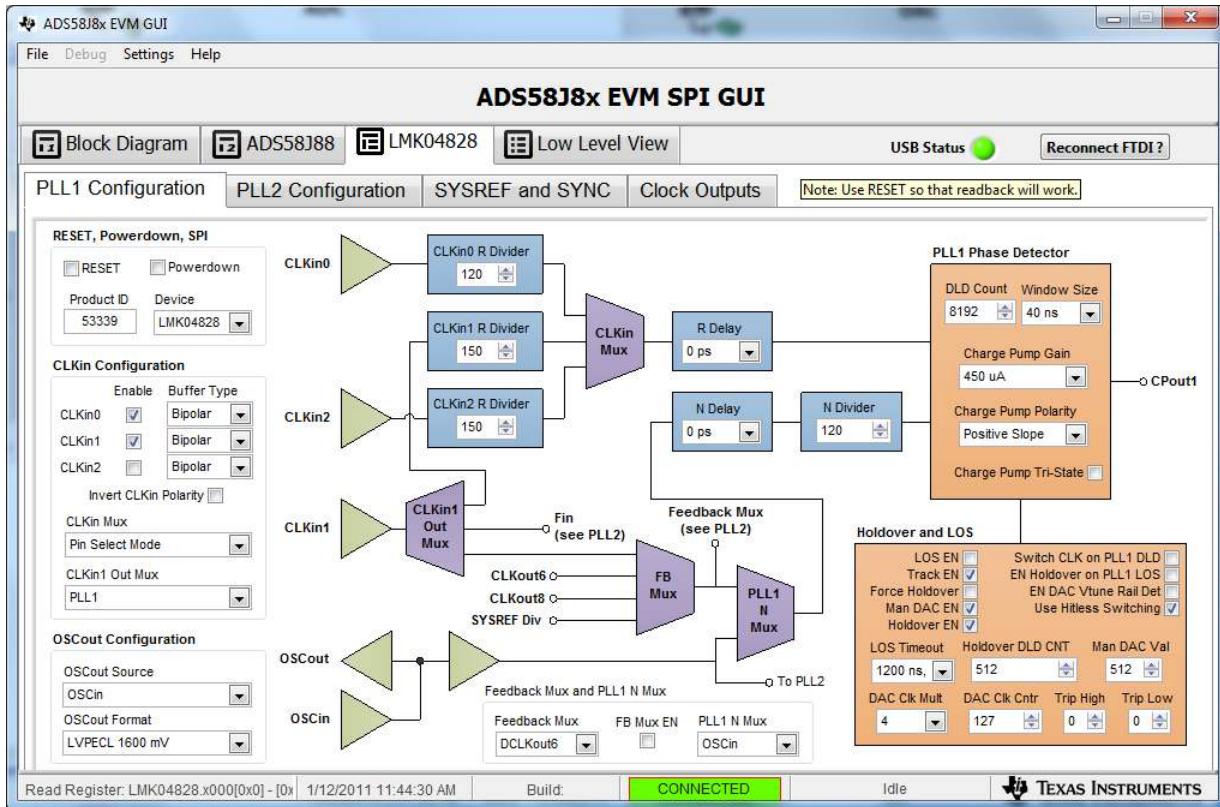

Figure 6. LMK04828 PLL1 Configuration Tab

2.2.5.1 PLL1 Configuration

Much of this panel is organized in block diagram format to help visualize the function of the controls. The function of PLL1 is to take an external reference clock, such as the 10-MHz reference from an oscillator on the EVM, and generate a clean, low-jitter intermediate-frequency clock for use by the second PLL loop. There are numerous integer divider values that may be used to create this intermediate frequency from the external reference. This tab also contains the reset and power down controls for the whole LMK04828 device. Consult the LMK04828 data sheet ([SNAS605](#)) and design tools for more information regarding the proper settings for configuring PLL1, particularly for the proper settings for the PLL1 phase detector and charge pump values.

2.2.5.2 PLL2 Configuration

Clicking the *PLL2 Configuration* opens the PLL2 Configuration tab as shown in Figure 7. Much of this panel is organized in block diagram format to help visualize the function of the controls. In this tab there is the control to select whether an external VCO is used or an internal VCO of frequency 2.5GHz or 3.0GHz. Several integer divider ratios can be set to lock the VCO to the frequency from PLL1, labeled as OSCin. After configuring PLL2 to select a VCO and lock it to the input reference resulting in the desired VCO frequency, this VCO frequency is then used to generate 14 clock outputs which are normally used as 7 pairs of device clock and SYSREF system reference clocks. One of the device clock/SYSREF pairs is connected to the FMC connector to source DCLK/SYSREF to the FPGA on the TSW14J56 capture card. Another DCLK/SYSREF pair is used to clock the ADS58J89. The other 5 pairs of clocks are normally powered down but may be configured as additional clock outputs. The block diagram at the bottom of the PLL2 Configuration tab illustrates some of the operations that might be applied to the 7 DCLK/SYSREF pairs such as divider ratios or delay adjustments. The next two tabs provide the controls to select all these available features that may be used to condition the DCLK/SYSREF pairs for a specific use. The LMK04828 datasheet is indispensable in understanding the function of each of these many controls and how these controls should be set for a specific use of the EVM.

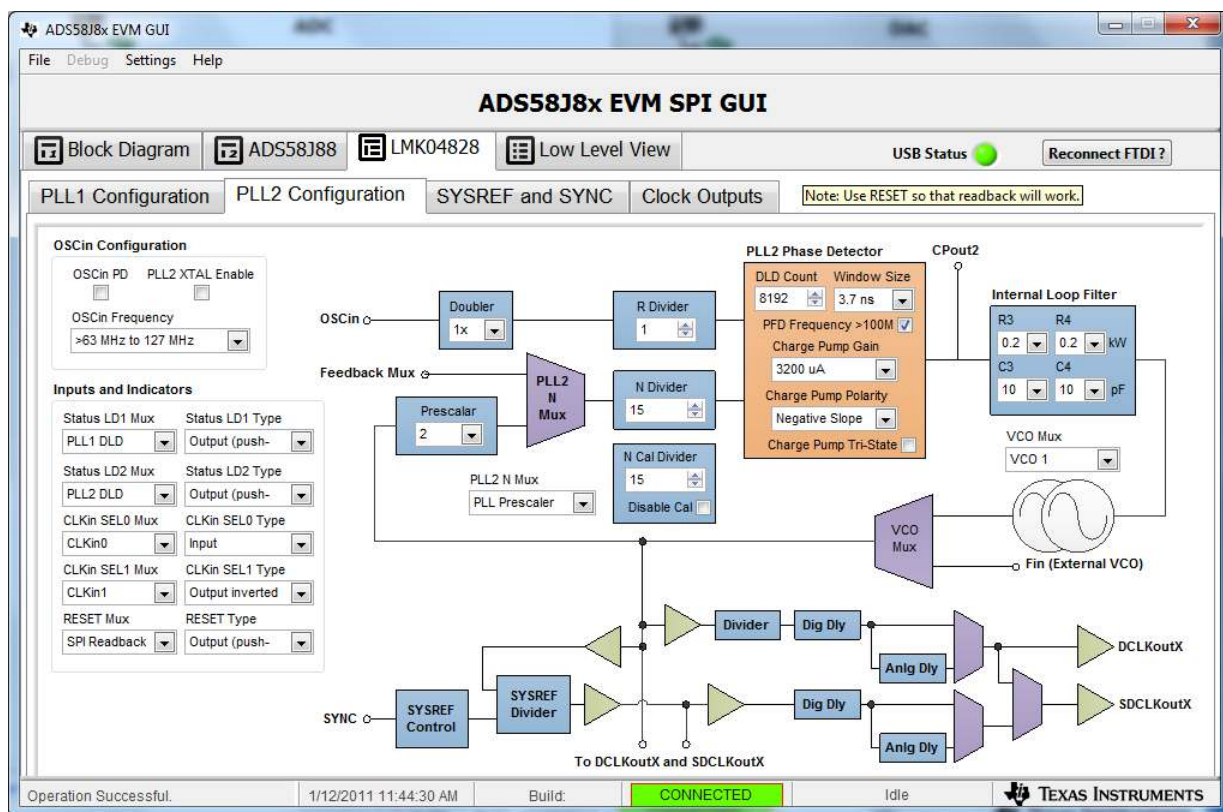

Figure 7. LMK04828 PLL2 Configuration Tab

2.2.5.3 Clock Output Controls

Clicking *Clock Outputs* opens the LMK04828 Clock Outputs tab, shown in Figure 8. This tab is organized into 7 sections representing the 7 pairs of DCLK/SYSREF that the LMK04828 can generate. For each of the 7 pairs of DCLK/SYSREF there are a number of controls that apply to both outputs, such as the option to power down the pair of signals completely if not needed. For both DCLK and SYSREF there is an option to select what type of output driver is to be used, such as LVDS or LVPECL. There are controls to enable things like delay or inversion. For the DCLK, there is a control to select a divider ration to divide the PLL2 VCO clock down to the desired output frequency. For example, if the ADS58J89 EVM is to be operated at 500Mps then the configuration file supplied with the GUI will select the 3.0GHz VCO and select a divider ratio of 6 to generate a 500-MHz DCLK. If the TSW14J56 capture card is used, the TSW14J56 needs to see a DCLK reference that is one-twentieth the line rate of the serial data stream so the divider ratio chosen is 12 to generate a 250-MHz DCLK to the FMC connector. These two divider ratios can be seen in Figure 8.

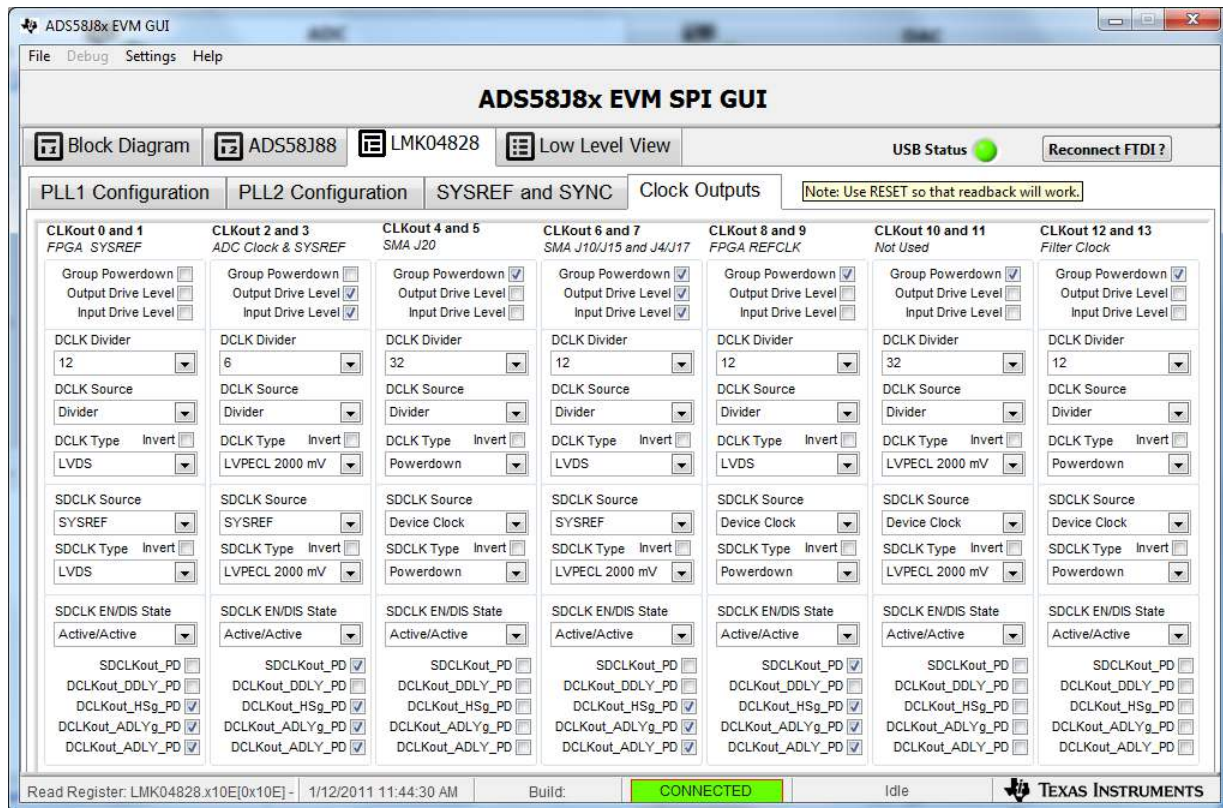

Figure 8. LMK04828 Clock Outputs Tab

2.2.5.4 SYSREF and SYNC Controls

Clicking *SYSREF and SYNC* opens the LMK04828 SYSREF and SYNC tab, shown in Figure 9. This tab has controls specific to the generation of the SYSREF outputs of the LMK04828. Along the top of the tab are controls that are common to all 7 of the SYSREF outputs, such as the SYSREF divider. One the JESD204B link is configured for a specific line rate and all JESD204B parameters such as L, M, F, and K are chosen then the SYSREF divider should be set to match the SYSREF rate to the Local MultiFrame Clock period, or LMFC period. For the default configuration of the ADS58J89 EVM as configured by the ADS58J89_500M_LMF881 config file, the device is set up for 2 lanes per channel, 1 octet per lane, with a K value of 32. The resulting SYSREF divider value is 480 as shown in Figure 9, matching the SYSREF rate to the LMFC rate of the ADS58J89 and TSW14J56 capture card configurations. Along the bottom of the tab are controls that are specific to each of the 7 SYSREF outputs, such as delay settings.

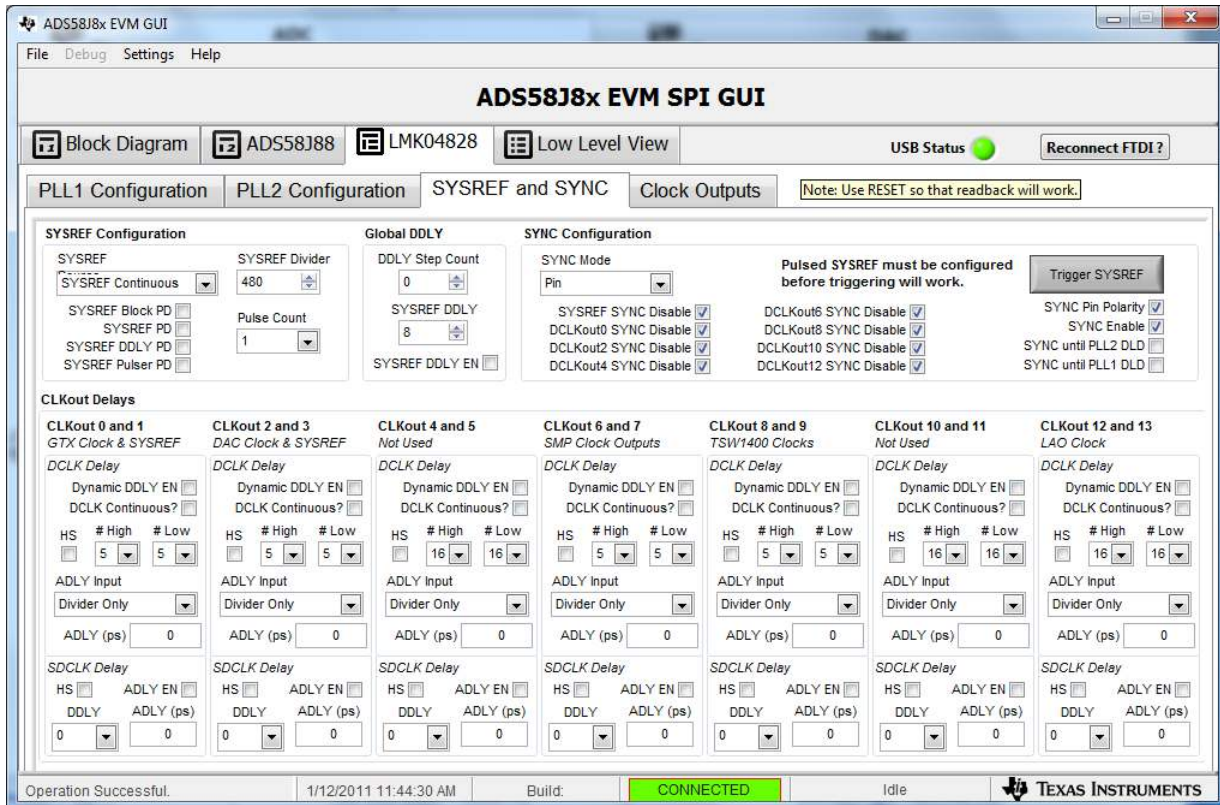

Figure 9. LMK04828 SYSREF and SYNC tab

2.2.5.5 Burst Mode Triggering

If the ADS58J89 receiver IC is not set up to use the decimation filter then the sample output will be at 500Msps if the sample clock is at 500-MHz. As described in the ADS58J89 datasheet, this sample output will be at a reduced resolution than the full 14bit resolution of the data converter in the front end of the device. The device may be triggered to output full 14bit resolution for a programmable length of time to be followed by a period of reduced resolution. The ADS58J89 EVM provides several ways to trigger the burst of high resolution output. A logic device on the EVM provides the trigger signal into the ADS58J89 by way of the OVRA and OVRC pins for channels A and B or C and D respectively. There are three ways to initiate this trigger. Pushbutton SW2 TRIGGER may be pressed to cause a trigger pulse. An external trigger pulse from some other equipment may be brought into the EVM by way of SMA connection J5 TRIG_IN. The Trigger Burst button on the ADS58J89 EVM SPI GUI may be used to initiate a trigger signal through a SPI write to the EVM. Any of these three events result in a trigger signal being sent to the ADS58J89. This trigger signal is latched and delayed a short amount of time and then also output on the SMA J26 TRIG_OUT. This output trigger may then be connected by 50 ohm coax cable to the TSW14J56 or other data capture device to begin data capture of the burst of high resolution output data. The small delay in TRIG_OUT is to allow the high resolution output to begin before the capture device begins capturing the sample data.

2.2.5.6 Low Level View

Clicking *Low Level View* opens the ADS58J8x EVM SPI GUI Low Level View tab, shown in Figure 10. This tab allows for direct read/write access to each bit of each SPI address for both the ADS58J89 and the LMK04828. This is also the tab used to load a previously saved configuration file or to save a new configuration file once a specific EVM configuration is properly set up. There are several ways to accomplish a read or write to a specific register. Highlighting a particular Register Name will cause the bits of that register to display on the right side of the window. If there is a bit in that register that has a datasheet definition then that definition is shown in the GUI. In the example shown in the figure, bit 4 of address 0x00 is the bit to choose between 3-wire SPI or 4-wire SPI for the LMK04828. To set a bit to a '1', check the box for that bit in the W column, then click Write Register. The GUI will write that register and then immediately read back that register. If the write was successful, then the R column should reflect what was just written from the W column. Another way to do a SPI access is to enter the address in the Address control at the bottom of the window and then click the Write Register or Read Register below it. Be sure to select the correct 'Block' first. If there are more than one devices with SPI access such as on this EVM, then there is a 'Block' for each device. The ADS58J8x EVM has a Block of ADS58J89 addresses and a block of LMK04828 addresses.

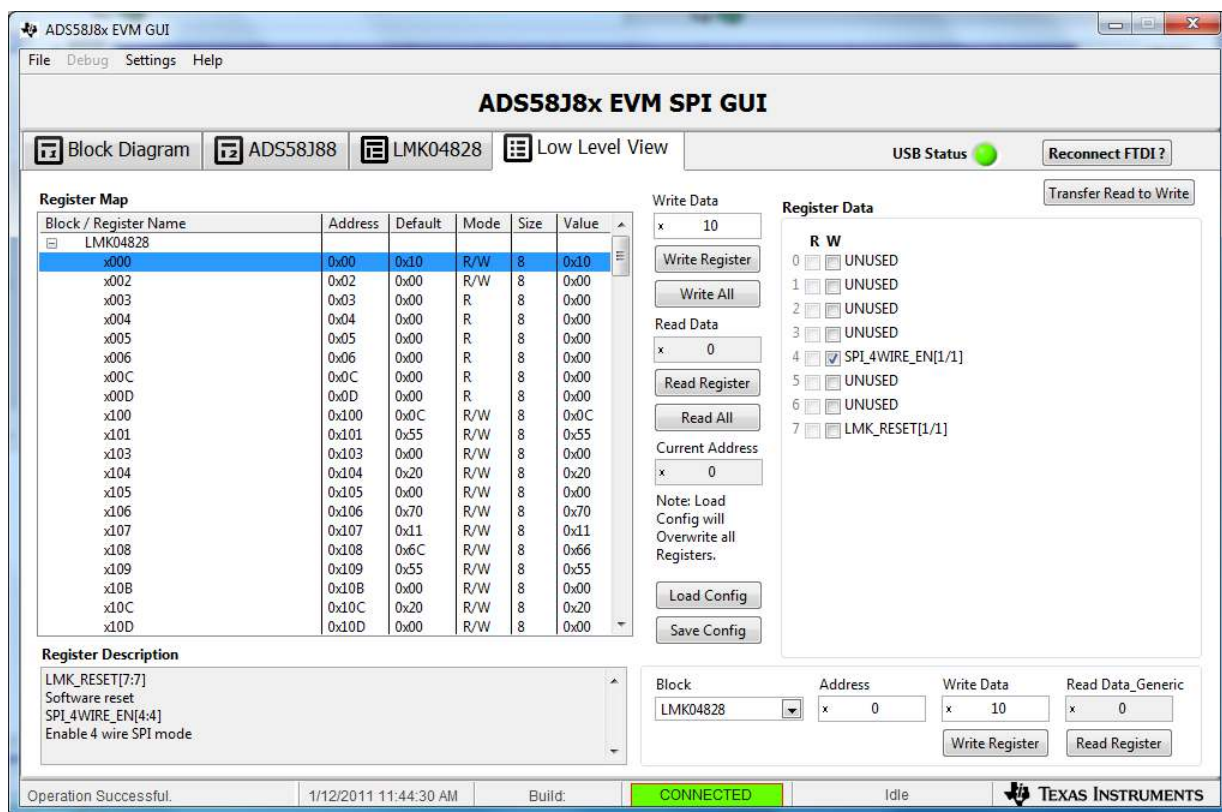

Figure 10. Low Level Controls Tab

3 Basic Test Setup

This section outlines basic testing of the ADS58J89EVM.

3.1 Test Block Diagram

The test setup for the ADS58J89EVM is shown in [Figure 11](#). The TSW14J56 Capture Card is used to capture data from the ADS58J89 EVM, which is then transferred to the computer for analysis in the HSDCPro software. The analog signal into a channel of the ADS58J89 can be from any high-quality low-jitter analog signal source. The clock source is from the LMK04828, but the board provides an option to use an external clock source, such as a HP8644B for the ADC sample clock. Note that a narrow bandpass filter is recommended on the analog source, which is necessary to remove as much phase noise from the signal source so as to achieve the best performance. The performance can be increased using external clock mode as this allows for the use of a filter on the clock source.

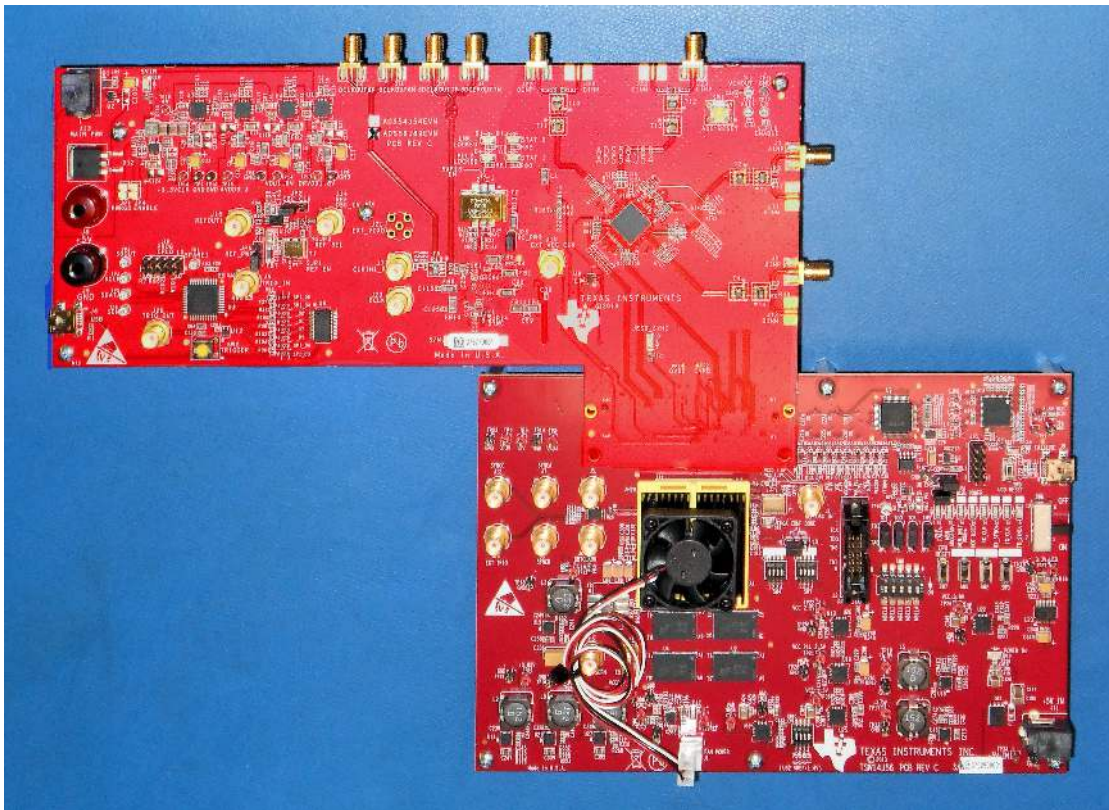

Figure 11. Test Setup

3.2 TSW14J56EVM Setup

See the TSW14J56EVM User's Guide ([SLWU079](#)) for a more detailed explanation of the TSW14J56 setup and its features. This document assumes that the HSDCPro software and the TSW14J56 pattern capture and generation board are both installed and functioning properly. This information can be found at <http://www.ti.com/tool/tsw14j56evm>.

3.3 ADS58J89EVM Quick-Start Procedure

Connect J3 of a ADS58J89EVM into J4 of a TSW14J56 JESD204B capture card.

3.3.1 TSW14J56 Data Capture Card

1. Connect a 5-V power supply to connector *J11* of the TSW14J56EVM.
2. Flip switch *SW6* to the *ON* position.
3. Insert a USB cable into the USB port on the TSW14J56. Connect the other end to the PC.

3.3.2 ADS58J89EVM

1. Connect a bench 5-V power supply, or equivalent, to the connector J13 using the supplied power supply cable. Alternatively, power may be supplied to the EVM by way of the red banana jack J8 for +5 V and the black banana jack J9 for ground.
2. Connect a USB cable to the USB port on the ADS58J89EVM and connect the other end to the PC.
3. Connect a signal source to an analog input SMA connector such as J1 (*A_INP*). For single-tone testing, a bandpass filter should be used to achieve the best SNR and harmonic performance.

3.3.3 ADS58J89 GUI

Use the following steps for setting up the ADS58J89 GUI:

1. Start the ADS58J89 GUI by selecting **Start Menu** → **Program Files** → **Texas Instruments ADCs** → **ADS58J8x GUI**.
2. In the upper right-hand corner, there is either a red or green LED indicator labeled **USB Status** and a button labeled **RECONNECT FTDI?**. If the LED button is red, then click the button until the LED indicator turns green. This indicates that the ADS58J89EVM is connected to the computer.
3. Under the ADC Controls tab of the ADS58J89 tab, click on the Reset ADC button. The ADS58J89 EVM SPI GUI always does a read-back of every register write to verify that the desired value was written. The ADS58J89 powers up in 3-wire SPI mode while the GUI requires 4-wire mode for the readback function to work properly. The Reset ADC button will reset the ADC and set the device in 4-wire mode so that the GUI will continue to work properly.
4. Under the PLL1 Controls tab of the LMK04828 tab, click on the Reset LMK button. The LMK04828 powers up in 3-wire SPI mode while the GUI requires 4-wire mode for the readback function to work properly. The Reset LMK button will reset the LMK04828 and set the device in 4-wire mode so that the GUI will continue to work properly.
5. On the low-level tab click the Load Config button. Choose one of the configuration files available. If choosing ADS58J88_500M_442.cfg, this configuration file will set the ADS58J89 to use four JESD204B lanes and set up the 2x decimation filter to output 250MSPS while the LMK04828 is configured to provide a 500-MHz device clock to the ADS58J89. If choosing ADS58J88_500M_881.cfg, the ADS58J89 will not decimate the sample output to 250MSPS but will output 500MSPS on 8 JESD204B lanes, and then either the SNRBoost feature of the ADS58J89 or the Burst Mode must be used to output high resolution data. If high resolution burst mode is used, the TSW14J56 must be set up to start data capture after receiving a trigger signal from the ADS58J89 EVM.
6. The two PLL's of the LMK04828 should now be locked. This is indicated on the ADS58J89 circuit board by the illuminated LED's, D4 (PLL2 LOCKED) and D1 labeled (LMK LOCKED).
7. The TSW14J56 capture card should now be receiving a DEVICE clock and a SYSREF clock. This causes the receiver FPGA to assert the JESD204B SYNC high, since synchronization has not been established with the transmitter ADC. This is indicated by LED D3 (JESD_SYNC) illuminating on the ADS58J89EVM. The SYSREF signal can be observed on either SMA J4 or J17 of the ADC EVM.
8. The TSW14J56 capture card should now be receiving valid data.
9. Since a periodic SYSREF signal acts as a sub-harmonic clock of the converter sampling clock and may have spurious effect on the converter performance, it may be turned off during normal operation once synchronization has been achieved. Click on the tab labeled *LMK0428 Clock Outputs* located at the top of the GUI. Check the control for SDCLKout_PD in the block of controls for clocks CLKout 2 and 3. (See figure 8) This will power down the SYSREF to the ADS58J89. The SYSREF must be running initially in order to establish a JESD204B link between the ADS58J89 and the FPGA on the TSW14J56 but after initialization the SYSREF is no longer needed and may result in clock spurs coupling into the ADS58J89, reducing performance.

NOTE: If SYSREF is turned off during normal operation, TX and RX devices must have the ability to generate a *Generate SYSREF* request to the LMK04828 clock generator whenever a synchronization request is detected at the SYNC interface.

10. If the JESD204B link does not get established, make sure the SYSREF MUX panel on the ADS58J89 GUI is set to SYSREF CONTINUOUS. If this is set to any other value, the SYSREF outputs will be disabled from the LMK04828, thus preventing synchronization from occurring.

3.3.4 High Speed Data Converter Pro (HSDCPro)

1. Start the HSDCPro software tool by selecting **Start Menu** → **All Programs** → **Texas Instruments ADCs** → **High Speed Data Converter Pro**.
2. When prompted for the serial number of the board, select the serial number that represents the TSW14J56 that has been connected to the ADS58J89. This number is on a sticker on the TSW14J56 board.
3. In the *Select ADC* drop-down box, select *ADS58J89_LMF442*. If it asks to download the firmware, select *Yes*. Multiple LEDs light up on the TSW14J56, once the firmware has finished downloading.
4. Select *Single Tone* from the *Test Selection* drop-down menu.
5. At the bottom-left corner, enter *250M* in the *ADC Sampling Rate (Fs)* box. If not using an external 10-MHz syncing signal from the analog signal source, then the 500-MHz sample clock from the LMK04828 will not be coherent with the analog signal generator. In this case, do not select *Auto Calculation of Coherent Frequencies*. If the clocks are synchronized with an external 10M syncing signal and are to be coherent then select *Auto Calculation of Coherent Frequencies*.
6. If a windowing function is desired, then *Blackman* should be selected above the plot window. If the clocks are synchronized with an external 10M syncing signal and coherent, select *Rectangular*.
7. All boards and software are now setup. Click the **Capture** button. A sample capture is shown in [Figure 12](#) for the ADS58J89 with a 250-MHz clock and 100-MHz input frequency.

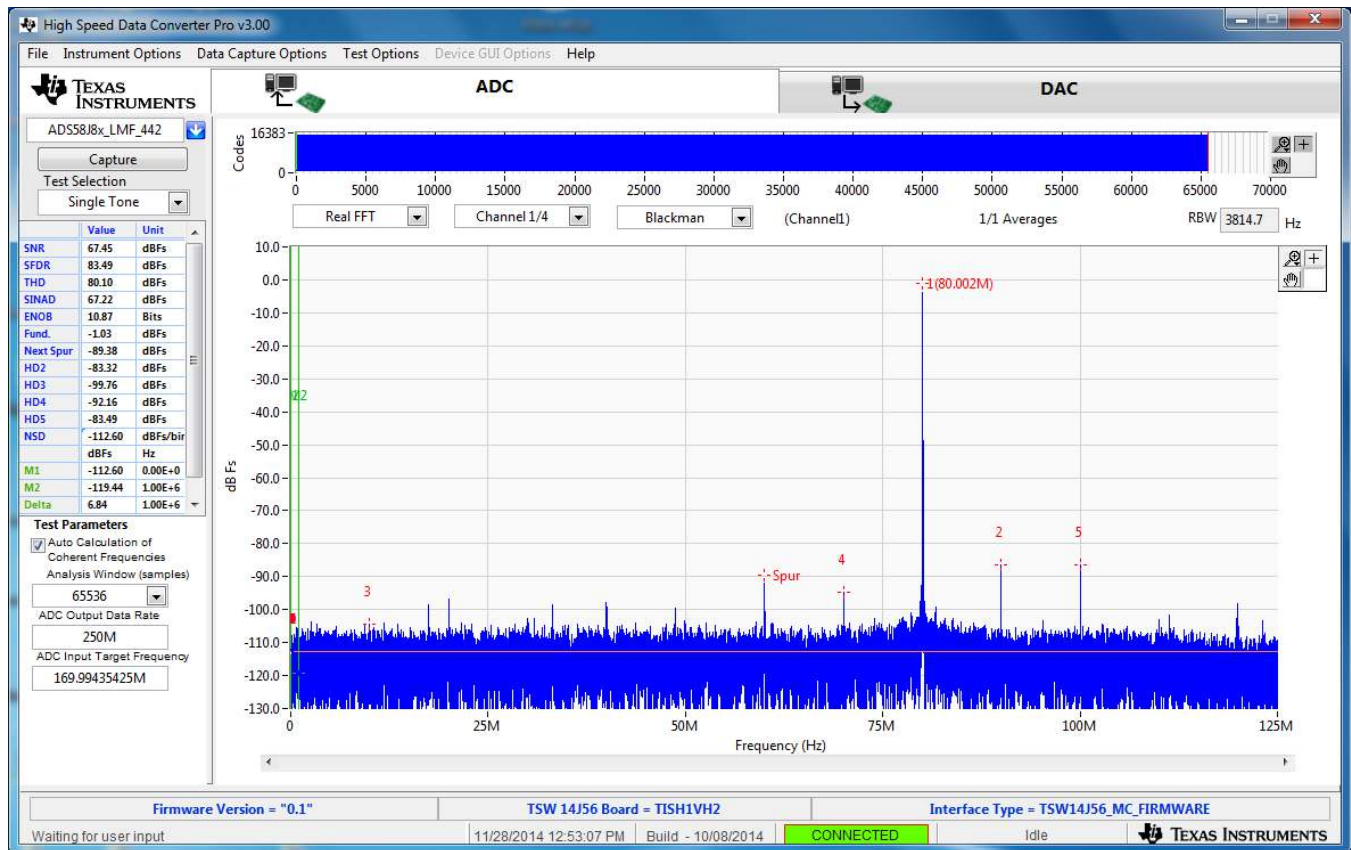

Figure 12. High Speed Data Converter Pro (HSDCPro) Sample Capture

Revision History

Changes from Original (December 2014) to A Revision	Page
• Changed first paragraph by removing reference to an included 5-VDC power supply to a <i>cable for connection to an external 5-VDC power supply</i>	1
• Changed <i>Block Diagram of the ADS58J89EVM</i> image.	2
• Changed the description in the <i>Input and Output Connectors and Jumper Descriptions of the ADS58J89EVM</i> table for <i>J13 (Main PWR)</i> from a <i>provided 5-VDC power supply</i> , to <i>+5-V bench supply (cable supplied)</i>	3
• Changed list item one in the <i>ADS58J89EVM</i> section.	17

NOTE: Page numbers for previous revisions may differ from page numbers in the current version.

STANDARD TERMS AND CONDITIONS FOR EVALUATION MODULES

1. *Delivery:* TI delivers TI evaluation boards, kits, or modules, including any accompanying demonstration software, components, or documentation (collectively, an "EVM" or "EVMs") to the User ("User") in accordance with the terms and conditions set forth herein. Acceptance of the EVM is expressly subject to the following terms and conditions.
 - 1.1 EVMs are intended solely for product or software developers for use in a research and development setting to facilitate feasibility evaluation, experimentation, or scientific analysis of TI semiconductors products. EVMs have no direct function and are not finished products. EVMs shall not be directly or indirectly assembled as a part or subassembly in any finished product. For clarification, any software or software tools provided with the EVM ("Software") shall not be subject to the terms and conditions set forth herein but rather shall be subject to the applicable terms and conditions that accompany such Software
 - 1.2 EVMs are not intended for consumer or household use. EVMs may not be sold, sublicensed, leased, rented, loaned, assigned, or otherwise distributed for commercial purposes by Users, in whole or in part, or used in any finished product or production system.
2. *Limited Warranty and Related Remedies/Disclaimers:*
 - 2.1 These terms and conditions do not apply to Software. The warranty, if any, for Software is covered in the applicable Software License Agreement.
 - 2.2 TI warrants that the TI EVM will conform to TI's published specifications for ninety (90) days after the date TI delivers such EVM to User. Notwithstanding the foregoing, TI shall not be liable for any defects that are caused by neglect, misuse or mistreatment by an entity other than TI, including improper installation or testing, or for any EVMs that have been altered or modified in any way by an entity other than TI. Moreover, TI shall not be liable for any defects that result from User's design, specifications or instructions for such EVMs. Testing and other quality control techniques are used to the extent TI deems necessary or as mandated by government requirements. TI does not test all parameters of each EVM.
 - 2.3 If any EVM fails to conform to the warranty set forth above, TI's sole liability shall be at its option to repair or replace such EVM, or credit User's account for such EVM. TI's liability under this warranty shall be limited to EVMs that are returned during the warranty period to the address designated by TI and that are determined by TI not to conform to such warranty. If TI elects to repair or replace such EVM, TI shall have a reasonable time to repair such EVM or provide replacements. Repaired EVMs shall be warranted for the remainder of the original warranty period. Replaced EVMs shall be warranted for a new full ninety (90) day warranty period.
3. *Regulatory Notices:*
 - 3.1 *United States*
 - 3.1.1 *Notice applicable to EVMs not FCC-Approved:*

This kit is designed to allow product developers to evaluate electronic components, circuitry, or software associated with the kit to determine whether to incorporate such items in a finished product and software developers to write software applications for use with the end product. This kit is not a finished product and when assembled may not be resold or otherwise marketed unless all required FCC equipment authorizations are first obtained. Operation is subject to the condition that this product not cause harmful interference to licensed radio stations and that this product accept harmful interference. Unless the assembled kit is designed to operate under part 15, part 18 or part 95 of this chapter, the operator of the kit must operate under the authority of an FCC license holder or must secure an experimental authorization under part 5 of this chapter.
 - 3.1.2 *For EVMs annotated as FCC – FEDERAL COMMUNICATIONS COMMISSION Part 15 Compliant:*

CAUTION

This device complies with part 15 of the FCC Rules. Operation is subject to the following two conditions: (1) This device may not cause harmful interference, and (2) this device must accept any interference received, including interference that may cause undesired operation.

Changes or modifications not expressly approved by the party responsible for compliance could void the user's authority to operate the equipment.

FCC Interference Statement for Class A EVM devices

NOTE: This equipment has been tested and found to comply with the limits for a Class A digital device, pursuant to part 15 of the FCC Rules. These limits are designed to provide reasonable protection against harmful interference when the equipment is operated in a commercial environment. This equipment generates, uses, and can radiate radio frequency energy and, if not installed and used in accordance with the instruction manual, may cause harmful interference to radio communications. Operation of this equipment in a residential area is likely to cause harmful interference in which case the user will be required to correct the interference at his own expense.

FCC Interference Statement for Class B EVM devices

NOTE: This equipment has been tested and found to comply with the limits for a Class B digital device, pursuant to part 15 of the FCC Rules. These limits are designed to provide reasonable protection against harmful interference in a residential installation. This equipment generates, uses and can radiate radio frequency energy and, if not installed and used in accordance with the instructions, may cause harmful interference to radio communications. However, there is no guarantee that interference will not occur in a particular installation. If this equipment does cause harmful interference to radio or television reception, which can be determined by turning the equipment off and on, the user is encouraged to try to correct the interference by one or more of the following measures:

- Reorient or relocate the receiving antenna.
- Increase the separation between the equipment and receiver.
- Connect the equipment into an outlet on a circuit different from that to which the receiver is connected.
- Consult the dealer or an experienced radio/TV technician for help.

3.2 Canada

3.2.1 For EVMs issued with an Industry Canada Certificate of Conformance to RSS-210

Concerning EVMs Including Radio Transmitters:

This device complies with Industry Canada license-exempt RSS standard(s). Operation is subject to the following two conditions: (1) this device may not cause interference, and (2) this device must accept any interference, including interference that may cause undesired operation of the device.

Concernant les EVMs avec appareils radio:

Le présent appareil est conforme aux CNR d'Industrie Canada applicables aux appareils radio exempts de licence. L'exploitation est autorisée aux deux conditions suivantes: (1) l'appareil ne doit pas produire de brouillage, et (2) l'utilisateur de l'appareil doit accepter tout brouillage radioélectrique subi, même si le brouillage est susceptible d'en compromettre le fonctionnement.

Concerning EVMs Including Detachable Antennas:

Under Industry Canada regulations, this radio transmitter may only operate using an antenna of a type and maximum (or lesser) gain approved for the transmitter by Industry Canada. To reduce potential radio interference to other users, the antenna type and its gain should be so chosen that the equivalent isotropically radiated power (e.i.r.p.) is not more than that necessary for successful communication. This radio transmitter has been approved by Industry Canada to operate with the antenna types listed in the user guide with the maximum permissible gain and required antenna impedance for each antenna type indicated. Antenna types not included in this list, having a gain greater than the maximum gain indicated for that type, are strictly prohibited for use with this device.

Concernant les EVMs avec antennes détachables

Conformément à la réglementation d'Industrie Canada, le présent émetteur radio peut fonctionner avec une antenne d'un type et d'un gain maximal (ou inférieur) approuvé pour l'émetteur par Industrie Canada. Dans le but de réduire les risques de brouillage radioélectrique à l'intention des autres utilisateurs, il faut choisir le type d'antenne et son gain de sorte que la puissance isotrope rayonnée équivalente (p.i.r.e.) ne dépasse pas l'intensité nécessaire à l'établissement d'une communication satisfaisante. Le présent émetteur radio a été approuvé par Industrie Canada pour fonctionner avec les types d'antenne énumérés dans le manuel d'usage et ayant un gain admissible maximal et l'impédance requise pour chaque type d'antenne. Les types d'antenne non inclus dans cette liste, ou dont le gain est supérieur au gain maximal indiqué, sont strictement interdits pour l'exploitation de l'émetteur.

3.3 Japan

3.3.1 *Notice for EVMs delivered in Japan:* Please see http://www.tij.co.jp/lstds/ti_ja/general/eStore/notice_01.page 日本国内に輸入される評価用キット、ボードについては、次のところをご覧ください。
http://www.tij.co.jp/lstds/ti_ja/general/eStore/notice_01.page

3.3.2 *Notice for Users of EVMs Considered "Radio Frequency Products" in Japan:* EVMs entering Japan may not be certified by TI as conforming to Technical Regulations of Radio Law of Japan.

If User uses EVMs in Japan, not certified to Technical Regulations of Radio Law of Japan, User is required by Radio Law of Japan to follow the instructions below with respect to EVMs:

1. Use EVMs in a shielded room or any other test facility as defined in the notification #173 issued by Ministry of Internal Affairs and Communications on March 28, 2006, based on Sub-section 1.1 of Article 6 of the Ministry's Rule for Enforcement of Radio Law of Japan,
2. Use EVMs only after User obtains the license of Test Radio Station as provided in Radio Law of Japan with respect to EVMs, or
3. Use of EVMs only after User obtains the Technical Regulations Conformity Certification as provided in Radio Law of Japan with respect to EVMs. Also, do not transfer EVMs, unless User gives the same notice above to the transferee. Please note that if User does not follow the instructions above, User will be subject to penalties of Radio Law of Japan.

【無線電波を送信する製品の開発キットをお使いになる際の注意事項】 開発キットの中には技術基準適合証明を受けていないものがあります。技術適合証明を受けていないもののご使用に際しては、電波法遵守のため、以下のいずれかの措置を取っていただく必要がありますのでご注意ください。

1. 電波法施行規則第6条第1項第1号に基づく平成18年3月28日総務省告示第173号で定められた電波暗室等の試験設備でご使用いただく。
2. 実験局の免許を取得後ご使用いただく。
3. 技術基準適合証明を取得後ご使用いただく。

なお、本製品は、上記の「ご使用にあたっての注意」を譲渡先、移転先に通知しない限り、譲渡、移転できないものとします。

上記を遵守頂けない場合は、電波法の罰則が適用される可能性があることをご留意ください。日本テキサス・インスツルメンツ株式会社
東京都新宿区西新宿 6 丁目 2 4 番 1 号
西新宿三井ビル

3.3.3 *Notice for EVMs for Power Line Communication:* Please see http://www.tij.co.jp/llds/ti_ja/general/eStore/notice_02.page
電力線搬送波通信についての開発キットをお使いになる際の注意事項については、次のところをご覧ください。http://www.tij.co.jp/llds/ti_ja/general/eStore/notice_02.page

4 *EVM Use Restrictions and Warnings:*

4.1 EVMS ARE NOT FOR USE IN FUNCTIONAL SAFETY AND/OR SAFETY CRITICAL EVALUATIONS, INCLUDING BUT NOT LIMITED TO EVALUATIONS OF LIFE SUPPORT APPLICATIONS.

4.2 User must read and apply the user guide and other available documentation provided by TI regarding the EVM prior to handling or using the EVM, including without limitation any warning or restriction notices. The notices contain important safety information related to, for example, temperatures and voltages.

4.3 *Safety-Related Warnings and Restrictions:*

4.3.1 User shall operate the EVM within TI's recommended specifications and environmental considerations stated in the user guide, other available documentation provided by TI, and any other applicable requirements and employ reasonable and customary safeguards. Exceeding the specified performance ratings and specifications (including but not limited to input and output voltage, current, power, and environmental ranges) for the EVM may cause personal injury or death, or property damage. If there are questions concerning performance ratings and specifications, User should contact a TI field representative prior to connecting interface electronics including input power and intended loads. Any loads applied outside of the specified output range may also result in unintended and/or inaccurate operation and/or possible permanent damage to the EVM and/or interface electronics. Please consult the EVM user guide prior to connecting any load to the EVM output. If there is uncertainty as to the load specification, please contact a TI field representative. During normal operation, even with the inputs and outputs kept within the specified allowable ranges, some circuit components may have elevated case temperatures. These components include but are not limited to linear regulators, switching transistors, pass transistors, current sense resistors, and heat sinks, which can be identified using the information in the associated documentation. When working with the EVM, please be aware that the EVM may become very warm.

4.3.2 EVMs are intended solely for use by technically qualified, professional electronics experts who are familiar with the dangers and application risks associated with handling electrical mechanical components, systems, and subsystems. User assumes all responsibility and liability for proper and safe handling and use of the EVM by User or its employees, affiliates, contractors or designees. User assumes all responsibility and liability to ensure that any interfaces (electronic and/or mechanical) between the EVM and any human body are designed with suitable isolation and means to safely limit accessible leakage currents to minimize the risk of electrical shock hazard. User assumes all responsibility and liability for any improper or unsafe handling or use of the EVM by User or its employees, affiliates, contractors or designees.

4.4 User assumes all responsibility and liability to determine whether the EVM is subject to any applicable international, federal, state, or local laws and regulations related to User's handling and use of the EVM and, if applicable, User assumes all responsibility and liability for compliance in all respects with such laws and regulations. User assumes all responsibility and liability for proper disposal and recycling of the EVM consistent with all applicable international, federal, state, and local requirements.

5. *Accuracy of Information:* To the extent TI provides information on the availability and function of EVMs, TI attempts to be as accurate as possible. However, TI does not warrant the accuracy of EVM descriptions, EVM availability or other information on its websites as accurate, complete, reliable, current, or error-free.

6. *Disclaimers:*
- 6.1 EXCEPT AS SET FORTH ABOVE, EVMS AND ANY WRITTEN DESIGN MATERIALS PROVIDED WITH THE EVM (AND THE DESIGN OF THE EVM ITSELF) ARE PROVIDED "AS IS" AND "WITH ALL FAULTS." TI DISCLAIMS ALL OTHER WARRANTIES, EXPRESS OR IMPLIED, REGARDING SUCH ITEMS, INCLUDING BUT NOT LIMITED TO ANY IMPLIED WARRANTIES OF MERCHANTABILITY OR FITNESS FOR A PARTICULAR PURPOSE OR NON-INFRINGEMENT OF ANY THIRD PARTY PATENTS, COPYRIGHTS, TRADE SECRETS OR OTHER INTELLECTUAL PROPERTY RIGHTS.
- 6.2 EXCEPT FOR THE LIMITED RIGHT TO USE THE EVM SET FORTH HEREIN, NOTHING IN THESE TERMS AND CONDITIONS SHALL BE CONSTRUED AS GRANTING OR CONFERRING ANY RIGHTS BY LICENSE, PATENT, OR ANY OTHER INDUSTRIAL OR INTELLECTUAL PROPERTY RIGHT OF TI, ITS SUPPLIERS/LICENSORS OR ANY OTHER THIRD PARTY, TO USE THE EVM IN ANY FINISHED END-USER OR READY-TO-USE FINAL PRODUCT, OR FOR ANY INVENTION, DISCOVERY OR IMPROVEMENT MADE, CONCEIVED OR ACQUIRED PRIOR TO OR AFTER DELIVERY OF THE EVM.
7. *USER'S INDEMNITY OBLIGATIONS AND REPRESENTATIONS.* USER WILL DEFEND, INDEMNIFY AND HOLD TI, ITS LICENSORS AND THEIR REPRESENTATIVES HARMLESS FROM AND AGAINST ANY AND ALL CLAIMS, DAMAGES, LOSSES, EXPENSES, COSTS AND LIABILITIES (COLLECTIVELY, "CLAIMS") ARISING OUT OF OR IN CONNECTION WITH ANY HANDLING OR USE OF THE EVM THAT IS NOT IN ACCORDANCE WITH THESE TERMS AND CONDITIONS. THIS OBLIGATION SHALL APPLY WHETHER CLAIMS ARISE UNDER STATUTE, REGULATION, OR THE LAW OF TORT, CONTRACT OR ANY OTHER LEGAL THEORY, AND EVEN IF THE EVM FAILS TO PERFORM AS DESCRIBED OR EXPECTED.
8. *Limitations on Damages and Liability:*
- 8.1 *General Limitations.* IN NO EVENT SHALL TI BE LIABLE FOR ANY SPECIAL, COLLATERAL, INDIRECT, PUNITIVE, INCIDENTAL, CONSEQUENTIAL, OR EXEMPLARY DAMAGES IN CONNECTION WITH OR ARISING OUT OF THESE TERMS AND CONDITIONS OR THE USE OF THE EVMS PROVIDED HEREUNDER, REGARDLESS OF WHETHER TI HAS BEEN ADVISED OF THE POSSIBILITY OF SUCH DAMAGES. EXCLUDED DAMAGES INCLUDE, BUT ARE NOT LIMITED TO, COST OF REMOVAL OR REINSTALLATION, ANCILLARY COSTS TO THE PROCUREMENT OF SUBSTITUTE GOODS OR SERVICES, RETESTING, OUTSIDE COMPUTER TIME, LABOR COSTS, LOSS OF GOODWILL, LOSS OF PROFITS, LOSS OF SAVINGS, LOSS OF USE, LOSS OF DATA, OR BUSINESS INTERRUPTION. NO CLAIM, SUIT OR ACTION SHALL BE BROUGHT AGAINST TI MORE THAN ONE YEAR AFTER THE RELATED CAUSE OF ACTION HAS OCCURRED.
- 8.2 *Specific Limitations.* IN NO EVENT SHALL TI'S AGGREGATE LIABILITY FROM ANY WARRANTY OR OTHER OBLIGATION ARISING OUT OF OR IN CONNECTION WITH THESE TERMS AND CONDITIONS, OR ANY USE OF ANY TI EVM PROVIDED HEREUNDER, EXCEED THE TOTAL AMOUNT PAID TO TI FOR THE PARTICULAR UNITS SOLD UNDER THESE TERMS AND CONDITIONS WITH RESPECT TO WHICH LOSSES OR DAMAGES ARE CLAIMED. THE EXISTENCE OF MORE THAN ONE CLAIM AGAINST THE PARTICULAR UNITS SOLD TO USER UNDER THESE TERMS AND CONDITIONS SHALL NOT ENLARGE OR EXTEND THIS LIMIT.
9. *Return Policy.* Except as otherwise provided, TI does not offer any refunds, returns, or exchanges. Furthermore, no return of EVM(s) will be accepted if the package has been opened and no return of the EVM(s) will be accepted if they are damaged or otherwise not in a resalable condition. If User feels it has been incorrectly charged for the EVM(s) it ordered or that delivery violates the applicable order, User should contact TI. All refunds will be made in full within thirty (30) working days from the return of the components(s), excluding any postage or packaging costs.
10. *Governing Law:* These terms and conditions shall be governed by and interpreted in accordance with the laws of the State of Texas, without reference to conflict-of-laws principles. User agrees that non-exclusive jurisdiction for any dispute arising out of or relating to these terms and conditions lies within courts located in the State of Texas and consents to venue in Dallas County, Texas. Notwithstanding the foregoing, any judgment may be enforced in any United States or foreign court, and TI may seek injunctive relief in any United States or foreign court.

Mailing Address: Texas Instruments, Post Office Box 655303, Dallas, Texas 75265
Copyright © 2015, Texas Instruments Incorporated

IMPORTANT NOTICE

Texas Instruments Incorporated and its subsidiaries (TI) reserve the right to make corrections, enhancements, improvements and other changes to its semiconductor products and services per JESD46, latest issue, and to discontinue any product or service per JESD48, latest issue. Buyers should obtain the latest relevant information before placing orders and should verify that such information is current and complete. All semiconductor products (also referred to herein as "components") are sold subject to TI's terms and conditions of sale supplied at the time of order acknowledgment.

TI warrants performance of its components to the specifications applicable at the time of sale, in accordance with the warranty in TI's terms and conditions of sale of semiconductor products. Testing and other quality control techniques are used to the extent TI deems necessary to support this warranty. Except where mandated by applicable law, testing of all parameters of each component is not necessarily performed.

TI assumes no liability for applications assistance or the design of Buyers' products. Buyers are responsible for their products and applications using TI components. To minimize the risks associated with Buyers' products and applications, Buyers should provide adequate design and operating safeguards.

TI does not warrant or represent that any license, either express or implied, is granted under any patent right, copyright, mask work right, or other intellectual property right relating to any combination, machine, or process in which TI components or services are used. Information published by TI regarding third-party products or services does not constitute a license to use such products or services or a warranty or endorsement thereof. Use of such information may require a license from a third party under the patents or other intellectual property of the third party, or a license from TI under the patents or other intellectual property of TI.

Reproduction of significant portions of TI information in TI data books or data sheets is permissible only if reproduction is without alteration and is accompanied by all associated warranties, conditions, limitations, and notices. TI is not responsible or liable for such altered documentation. Information of third parties may be subject to additional restrictions.

Resale of TI components or services with statements different from or beyond the parameters stated by TI for that component or service voids all express and any implied warranties for the associated TI component or service and is an unfair and deceptive business practice. TI is not responsible or liable for any such statements.

Buyer acknowledges and agrees that it is solely responsible for compliance with all legal, regulatory and safety-related requirements concerning its products, and any use of TI components in its applications, notwithstanding any applications-related information or support that may be provided by TI. Buyer represents and agrees that it has all the necessary expertise to create and implement safeguards which anticipate dangerous consequences of failures, monitor failures and their consequences, lessen the likelihood of failures that might cause harm and take appropriate remedial actions. Buyer will fully indemnify TI and its representatives against any damages arising out of the use of any TI components in safety-critical applications.

In some cases, TI components may be promoted specifically to facilitate safety-related applications. With such components, TI's goal is to help enable customers to design and create their own end-product solutions that meet applicable functional safety standards and requirements. Nonetheless, such components are subject to these terms.

No TI components are authorized for use in FDA Class III (or similar life-critical medical equipment) unless authorized officers of the parties have executed a special agreement specifically governing such use.

Only those TI components which TI has specifically designated as military grade or "enhanced plastic" are designed and intended for use in military/aerospace applications or environments. Buyer acknowledges and agrees that any military or aerospace use of TI components which have **not** been so designated is solely at the Buyer's risk, and that Buyer is solely responsible for compliance with all legal and regulatory requirements in connection with such use.

TI has specifically designated certain components as meeting ISO/TS16949 requirements, mainly for automotive use. In any case of use of non-designated products, TI will not be responsible for any failure to meet ISO/TS16949.

Products

Audio	www.ti.com/audio
Amplifiers	amplifier.ti.com
Data Converters	dataconverter.ti.com
DLP® Products	www.dlp.com
DSP	dsp.ti.com
Clocks and Timers	www.ti.com/clocks
Interface	interface.ti.com
Logic	logic.ti.com
Power Mgmt	power.ti.com
Microcontrollers	microcontroller.ti.com
RFID	www.ti-rfid.com
OMAP Applications Processors	www.ti.com/omap
Wireless Connectivity	www.ti.com/wirelessconnectivity

Applications

Automotive and Transportation	www.ti.com/automotive
Communications and Telecom	www.ti.com/communications
Computers and Peripherals	www.ti.com/computers
Consumer Electronics	www.ti.com/consumer-apps
Energy and Lighting	www.ti.com/energy
Industrial	www.ti.com/industrial
Medical	www.ti.com/medical
Security	www.ti.com/security
Space, Avionics and Defense	www.ti.com/space-avionics-defense
Video and Imaging	www.ti.com/video

TI E2E Community

e2e.ti.com