

REVISIONS					
REV	ECO	DESCRIPTION	DATE	BY	APPR
A1	--	RELEASE NEW DRAWING	16/NOV/22	MILO	TOMMY

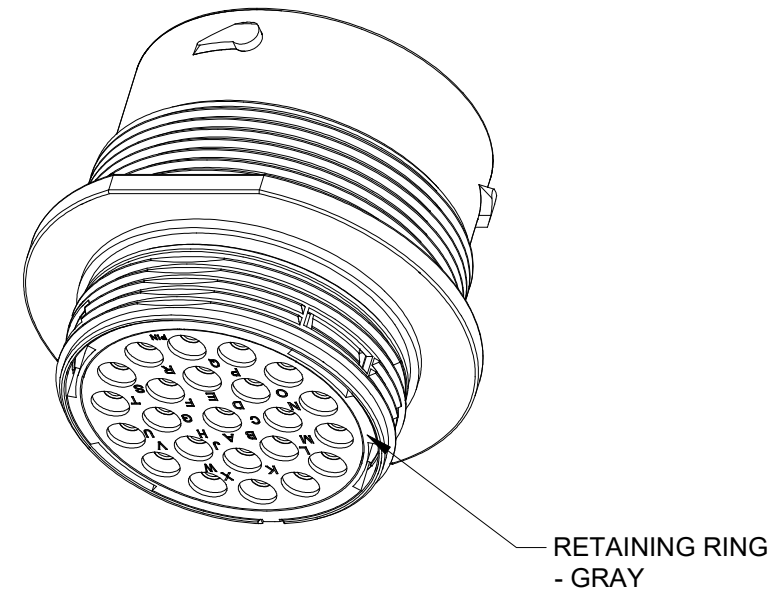
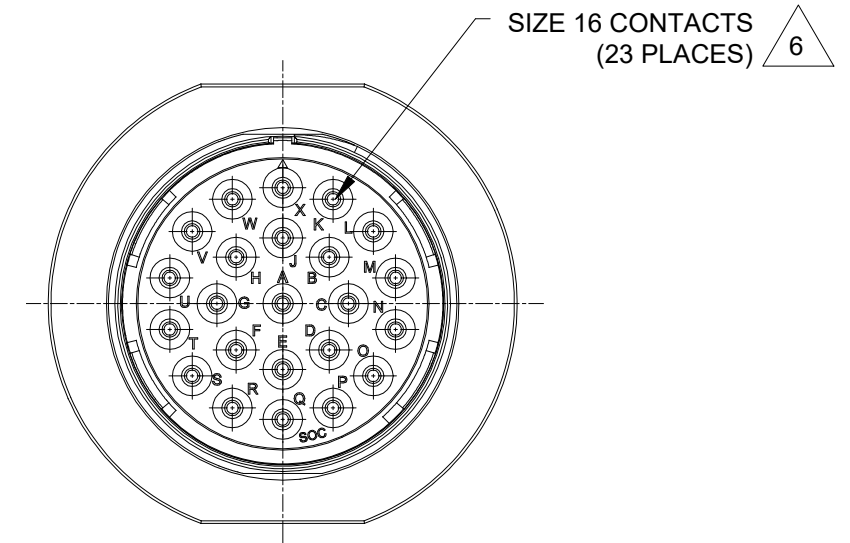
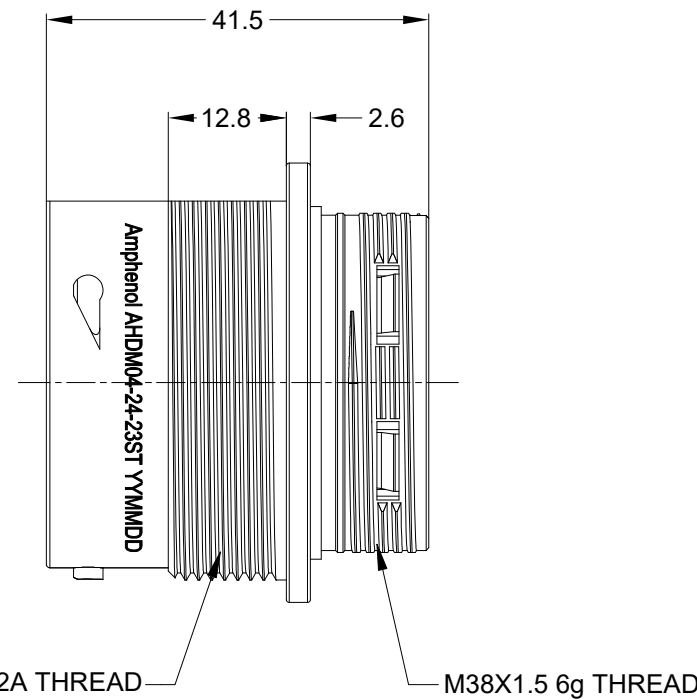
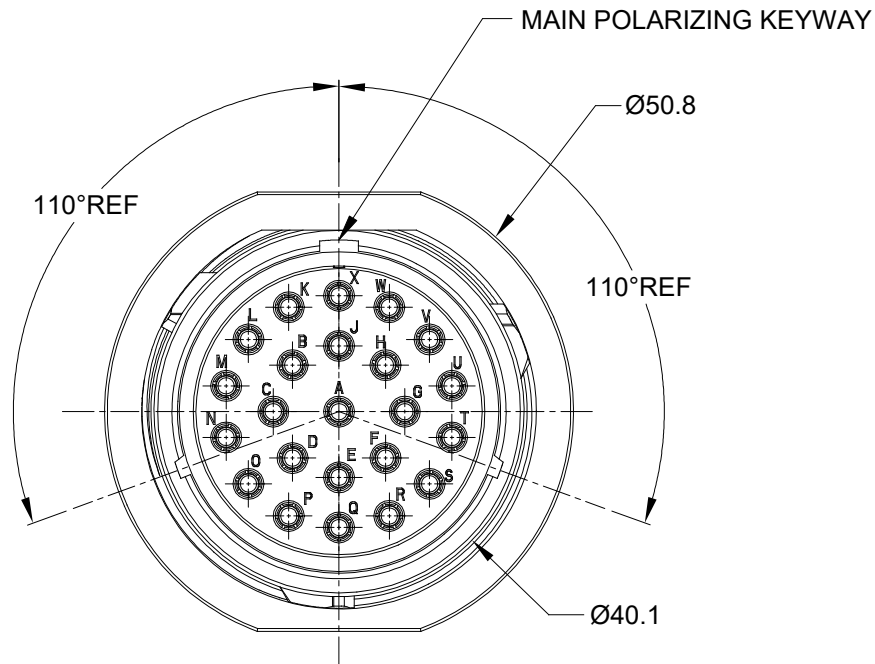

NOTES: UNLESS OTHERWISE SPECIFIED

- MATERIAL:**
SHELL: ZINC ALLOY, NICKEL PLATED
INSERT AND RETAINING RING: THERMOPLASTIC
SEAL: SILICONE RUBBER
- MODIFICATIONS:** THREADED HOUSING; THIN WALL DIA. WIRE SEAL
- SPECIFICATIONS:**
 - OPERATING TEMPERATURE: -55°C TO +125°C.
 - DIELECTRIC WITHSTANDING VOLTAGE: LESS THAN 2 MILLIAMPS CURRENT LEAKAGE @ 1500 VOLTS AC.
 - INSULATION RESISTANCE: 1000 MEGOHM MIN @ 25°C.
 - MOISTURE RESISTANCE:
IP68(IM OF WATER FOR A PERIOD OF 24 HOURS, MATED CONDITION);
IP69K(MATED CONDITION)
 - MATING CYCLE DURABILITY: 100 CYCLES
 - RoHS COMPLIANT
- MATING PART:** AHDM06-24-23P* (* = SEAL TYPE)
- ALL DIMENSIONS ARE FOR REFERENCE USE ONLY.**

6 CONTACT SIZE AND WIRE RANGE:

CONTACT SIZE	MIN.INSUL O.D	MAX.INSUL O.D	WIRE RANGE mm ²
16	2.23mm (.088in)	2.69mm (.106in)	14-20AWG (2.0-0.5mm ²)

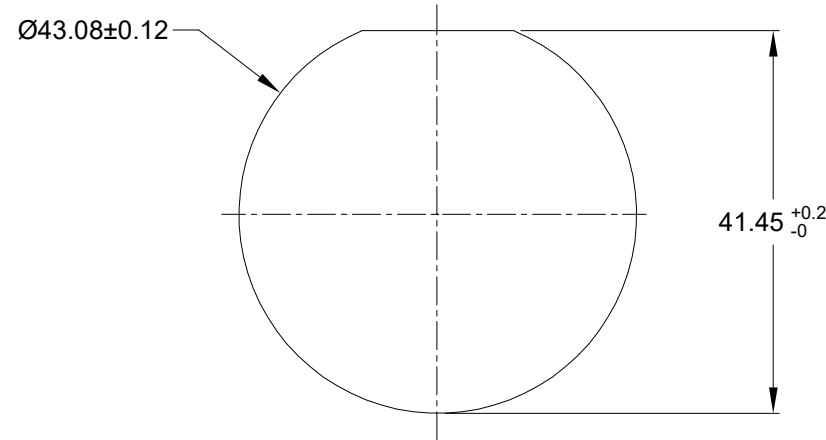

RECOMMENDED PANEL MOUNTING HOLE
RECOMMENDED PANEL THICKNESS: 1.6 TO 4.7MM

QUANTITY	AHDM04-24-23ST	DESCRIPTION	ITEM
		REF: HD34-24-23ST	

MATERIALS LIST											
UNLESS OTHERWISE SPECIFIED 1) All dimensions are in metric(mm). 2) Tolerances are as follows: 1 PL DEC ±0.30 2 PL DEC ±0.15 3 PL DEC ±0.08 3) Note reference = X		SIGNATURES DRAWN: MILO.DONG CHECKED: SULLENZHANG ENGINEER: APPROVAL: TOMMY.XIE	DATE 18/NOV/22 17/NOV/22 18/NOV/22								
MATERIAL SPECIFICATIONS: WEIGHT: 110.1g		 Sine Systems - www.amphenol-sine.com 44724 Morley Drive Clinton Township, MI 48036 23POS,RECEPTACLE,SOCKET,SZ24, THIN WIRE SEAL,AHDM									
PROCESS SPECIFICATIONS:		THIS DRAWING IS SUPPLIED FOR INFORMATION ONLY. DESIGN FEATURES, SPECIFICATIONS AND PERFORMANCE DATA SHOWN HEREON ARE THE PROPERTY OF THE AMPHENOL CORPORATION. NO RIGHTS OF REPRODUCTION ARE IMPLIED. ALL DIMENSIONS ARE SUBJECT TO NORMAL MANUFACTURING VARIATIONS.	<table border="1"> <tr> <th>SIZE</th> <th>TYPE</th> <th>DWG NO:</th> <th>REVISION</th> </tr> <tr> <td>B</td> <td>C-</td> <td>AHDM04-24-23ST</td> <td>A1</td> </tr> </table>	SIZE	TYPE	DWG NO:	REVISION	B	C-	AHDM04-24-23ST	A1
SIZE	TYPE	DWG NO:	REVISION								
B	C-	AHDM04-24-23ST	A1								
NEXT ASSY:		SCALE: NONE	DURAMATE SHEET 1 OF 1								

TITLE: 23POS,RECEPTACLE,SOCKET,SZ24,THIN WIRE SEAL,AHDM
DWG NO: AHDM04-24-23ST
REV: A1
SH: 1
OF: 1