



June 2015

DF005S1 - DF10S1 Bridge Rectifier

Features

- Maximum Surge Rating: $I_{FSM} = 35\text{ A}$
 $I^2t = 5.1\text{ A}^2\text{Sec}$
- Optimized V_F : Typical 0.95 V at 1 A, 25°C
- DF10S Socket Compatible
- Glass Passivated Junctions
- Lead Free Compliant to EU RoHS 2002/95/EU Directives
- Green Molding Compound: IEC61249
- Qualified with IR Reflow and Wave Soldering

Description

With the ever-pressing need to improve power supply efficiency, improve surge rating, improve reliability, and reduce size, the DFxS1 family sets a new standard in performance and cost saving.

The DFxS1 family balances performance against cost. The design offers a moderate surge rating of 35 A required to handle inrush surge and maintain good reliability, with fair price.

The DFxS1 achieves good performance in a SDIP surface mount form factor, reducing board space and volumetric requirements vs. competitive devices.

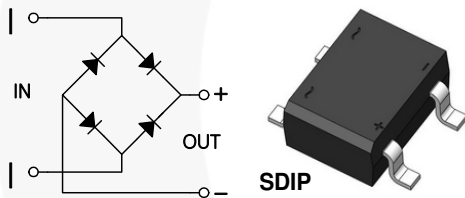

Ordering Information

Part Number	Top Mark	Package	Packing Method
DF005S1	DF005S1	SDIP 4L	Tape and Reel
DF01S1	DF01S1	SDIP 4L	Tape and Reel
DF02S1	DF02S1	SDIP 4L	Tape and Reel
DF04S1	DF04S1	SDIP 4L	Tape and Reel
DF06S1	DF06S1	SDIP 4L	Tape and Reel
DF08S1	DF08S1	SDIP 4L	Tape and Reel
DF10S1	DF10S1	SDIP 4L	Tape and Reel

Absolute Maximum Ratings

Stresses exceeding the absolute maximum ratings may damage the device. The device may not function or be operable above the recommended operating conditions and stressing the parts to these levels is not recommended. In addition, extended exposure to stresses above the recommended operating conditions may affect device reliability. The absolute maximum ratings are stress ratings only. Values are at $T_A = 25^\circ\text{C}$ unless otherwise noted.

Symbol	Parameter	Value							Unit
		DF005S1	DF01S1	DF02S1	DF04S1	DF06S1	DF08S1	DF10S1	
V_{RRM}	Maximum Recurrent Peak Reverse Voltage	50	100	200	400	600	800	1000	V
V_{RMS}	Maximum RMS Bridge Input Voltage	35	70	140	280	420	560	700	V
V_{DC}	Maximum DC Blocking Voltage	50	100	200	400	600	800	1000	V
$I_{F(AV)}$	Maximum Average Forward Current $T_A = 40^\circ\text{C}$	1.0							A
I_{FSM}	Peak Forward Surge Current 8.3 ms Single Half-Sine Wave Superimposed on Rated Load (JEDEC Method)	35							A
T_{STG}	Storage Temperature Range	-55 to +150							$^\circ\text{C}$
T_J	Operating Junction Temperature Range	-55 to +150							$^\circ\text{C}$

Thermal Characteristics⁽¹⁾

Symbol	Parameter	Conditions	Max.	Unit
$R_{\theta JA}$	Thermal Resistance, Junction to Ambient	Single-Die Measurement (Maximum Land Pattern: 13 x 13 mm)	65	$^\circ\text{C/W}$
		Multi-Die Measurement (Maximum Land Pattern: 13 x 13 mm)	50	
		Multi-Die Measurement (Minimum Land Pattern: 1.3 x 1.5 mm)	105	
ψ_{JL}	Thermal Characterization Parameter, Junction to Lead	Single-Die Measurement (Maximum and Minimum Land Pattern)	27	$^\circ\text{C/W}$

Note:

- The thermal resistances ($R_{\theta JA}$ & ψ_{JL}) are characterized with the device mounted on the following FR4 printed circuit boards, as shown in Figure 1 and Figure 2, PCB size: 76.2 x 114.3 mm.
Heating effect from adjacent dice is considered and only two dice are powered at the same time.

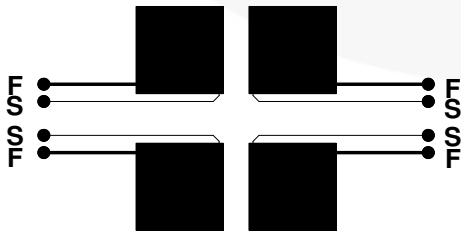

Figure 1. Maximum Pads of 2 oz Copper



Figure 2. Minimum Pads of 2 oz Copper

Electrical Characteristics

Values are at $T_A = 25^\circ\text{C}$ unless otherwise noted.

Symbol	Parameter	Conditions	Min.	Typ.	Max.	Unit
V_F	Forward Voltage Drop per Bridge Element	$I_F = 1.0\text{ A}$			1.1	V
I_R	DC Reverse Current at Rated DC Blocking Voltage	$T_J = 25^\circ\text{C}$			3	μA
		$T_J = 125^\circ\text{C}$			500	
I^2t	Rating for Fusing ($t < 8.3\text{ ms}$)				5.1	A^2S
C_J	Junction Capacitance	$V_R = 4.0\text{ V}$, $f = 1.0\text{ MHz}$		10		pF

Typical Performance Characteristics

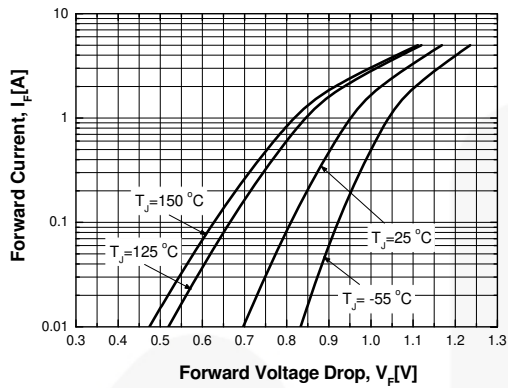

Figure 3. Typical Instantaneous Forward Characteristics

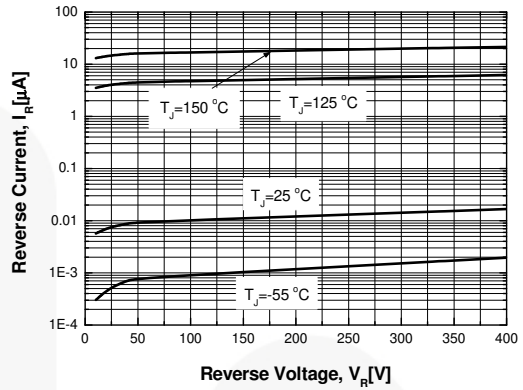

Figure 4. Typical Reverse Characteristics

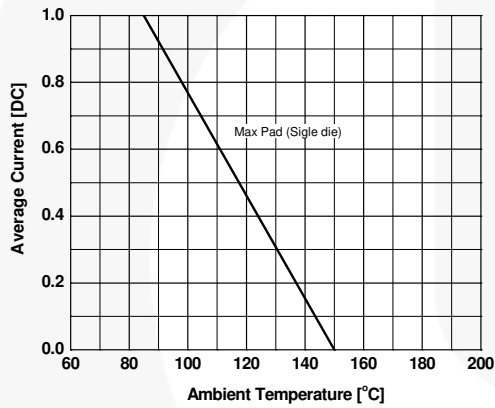

Figure 5. Maximum Average Current vs. Ambient Temperature

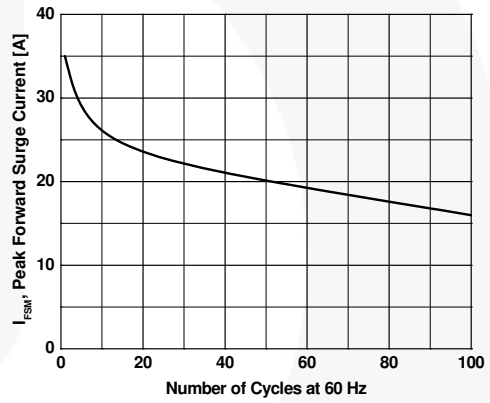

Figure 6. Peak Forward Surge Current vs. Number of Cycles at 60Hz

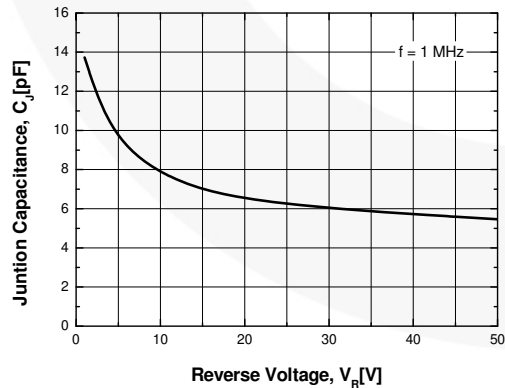
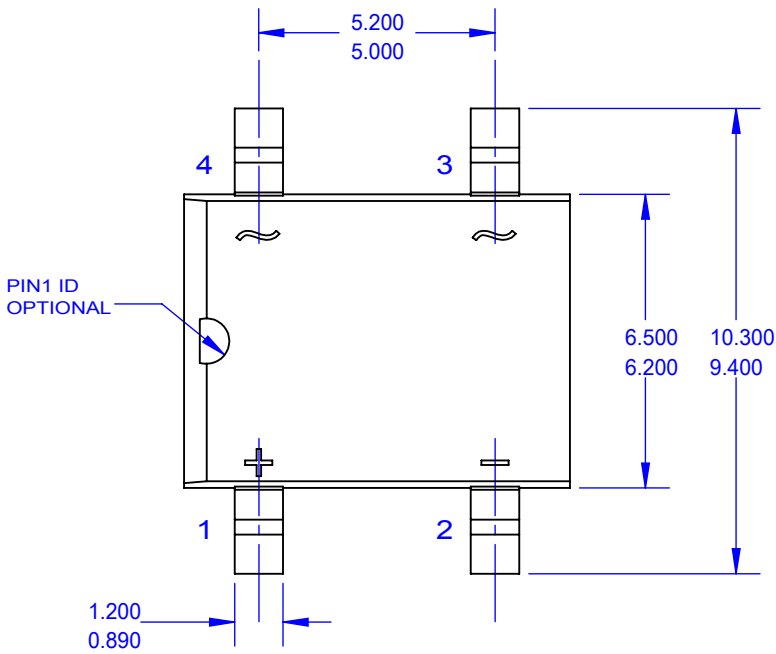
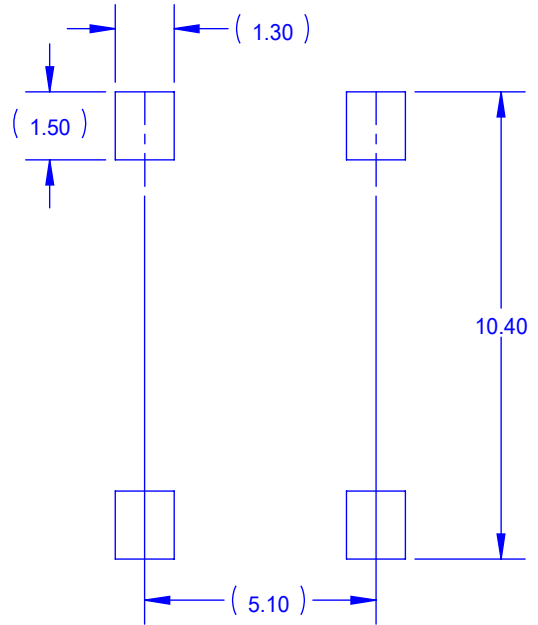

Figure 7. Typical Junction Capacitance



TOP VIEW



LAND PATTERN RECOMMENDATION

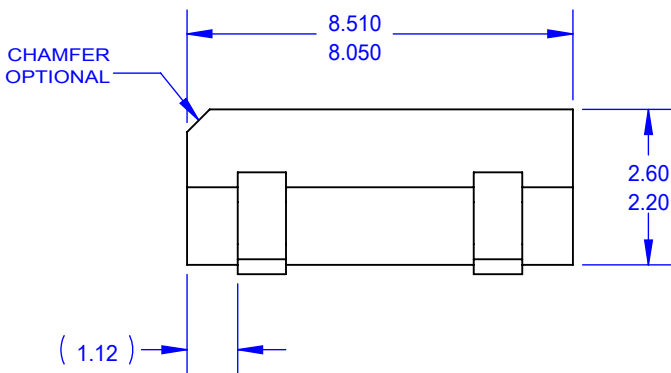

SIDE VIEW

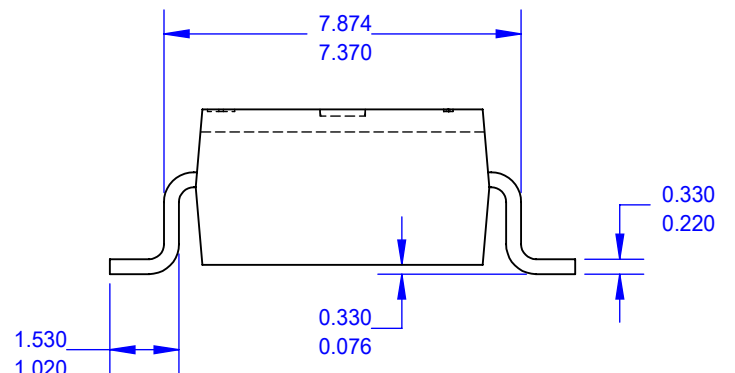

END VIEW

NOTES:





- A. THIS PACKAGE DOES NOT CONFORM TO ANY REFERENCE STANDARD.
- B. ALL DIMENSIONS ARE IN MILLIMETERS.
- C. DIMENSIONS ARE EXCLUSIVE OF BURRS, MOLD FLASH AND TIE BAR PROTRUSIONS.
- G. DRAWING FILE NAME: MKT-SDIP04AREV5.





TRADEMARKS

The following includes registered and unregistered trademarks and service marks, owned by Fairchild Semiconductor and/or its global subsidiaries, and is not intended to be an exhaustive list of all such trademarks.

- | | | | |
|---|--|---|---|
| AccuPower™ | F-PFS™ | OPTOPLANAR® |  |
| AttitudeEngine™ | FRFET® |  | TinyBoost® |
| Awinda® | Global Power Resource SM | Power Supply WebDesigner™ | TinyBuck® |
| AX-CAP®* | GreenBridge™ | PowerTrench® | TinyCalc™ |
| BitSiC™ | Green FPS™ | PowerXS™ | TinyLogic® |
| Build it Now™ | Green FPS™ e-Series™ | Programmable Active Droop™ | TINYOPTO™ |
| CorePLUS™ | Gmax™ | QFET® | TinyPower™ |
| CorePOWER™ | GTO™ | QS™ | TinyPWM™ |
| CROSSVOL™ | IntelliMAX™ | Quiet Series™ | TinyWire™ |
| CTL™ | ISOPLANAR™ | RapidConfigure™ | TranSiC™ |
| Current Transfer Logic™ | Making Small Speakers Sound Louder and Better™ |  | TriFault Detect™ |
| DEUXPEED® | MegaBuck™ | Saving our world, 1mW/W/kW at a time™ | TRUECURRENT®* |
| Dual Cool™ | MICROCOUPLER™ | SignalWise™ | μSerDes™ |
| EcoSPARK® | MicroFET™ | SmartMax™ |  |
| EfficientMax™ | MicroPak™ | SMART START™ | UHC® |
| ESBC™ | MicroPak2™ | Solutions for Your Success™ | Ultra FRFET™ |
|  | MillerDrive™ | SPM® | UniFET™ |
| Fairchild® | MotionMax™ | STEALTH™ | VCX™ |
| Fairchild Semiconductor® | MotionGrid® | SuperFET® | VisualMax™ |
| FACT Quiet Series™ | MTi® | SuperSOT™-3 | VoltagePlus™ |
| FACT® | MTx® | SuperSOT™-6 | XS™ |
| FastvCore™ | MVN® | SuperSOT™-8 | Xsens™ |
| FETBench™ | mWSaver® | SupreMOS® | 仙童® |
| FPS™ | OptoHiT™ | SyncFET™ | |
| | OPTOLOGIC® | Sync-Lock™ | |

* Trademarks of System General Corporation, used under license by Fairchild Semiconductor.

DISCLAIMER

FAIRCHILD SEMICONDUCTOR RESERVES THE RIGHT TO MAKE CHANGES WITHOUT FURTHER NOTICE TO ANY PRODUCTS HEREIN TO IMPROVE RELIABILITY, FUNCTION, OR DESIGN. TO OBTAIN THE LATEST, MOST UP-TO-DATE DATASHEET AND PRODUCT INFORMATION, VISIT OUR WEBSITE AT [HTTP://WWW.FAIRCHILDSEMI.COM](http://www.fairchildsemi.com). FAIRCHILD DOES NOT ASSUME ANY LIABILITY ARISING OUT OF THE APPLICATION OR USE OF ANY PRODUCT OR CIRCUIT DESCRIBED HEREIN; NEITHER DOES IT CONVEY ANY LICENSE UNDER ITS PATENT RIGHTS, NOR THE RIGHTS OF OTHERS. THESE SPECIFICATIONS DO NOT EXPAND THE TERMS OF FAIRCHILD'S WORLDWIDE TERMS AND CONDITIONS, SPECIFICALLY THE WARRANTY THEREIN, WHICH COVERS THESE PRODUCTS.

AUTHORIZED USE

Unless otherwise specified in this data sheet, this product is a standard commercial product and is not intended for use in applications that require extraordinary levels of quality and reliability. This product may not be used in the following applications, unless specifically approved in writing by a Fairchild officer: (1) automotive or other transportation, (2) military/aerospace, (3) any safety critical application – including life critical medical equipment – where the failure of the Fairchild product reasonably would be expected to result in personal injury, death or property damage. Customer's use of this product is subject to agreement of this Authorized Use policy. In the event of an unauthorized use of Fairchild's product, Fairchild accepts no liability in the event of product failure. In other respects, this product shall be subject to Fairchild's Worldwide Terms and Conditions of Sale, unless a separate agreement has been signed by both Parties.

ANTI-COUNTERFEITING POLICY

Fairchild Semiconductor Corporation's Anti-Counterfeiting Policy. Fairchild's Anti-Counterfeiting Policy is also stated on our external website, www.fairchildsemi.com, under Terms of Use

Counterfeiting of semiconductor parts is a growing problem in the industry. All manufacturers of semiconductor products are experiencing counterfeiting of their parts. Customers who inadvertently purchase counterfeit parts experience many problems such as loss of brand reputation, substandard performance, failed applications, and increased cost of production and manufacturing delays. Fairchild is taking strong measures to protect ourselves and our customers from the proliferation of counterfeit parts. Fairchild strongly encourages customers to purchase Fairchild parts either directly from Fairchild or from Authorized Fairchild Distributors who are listed by country on our web page cited above. Products customers buy either from Fairchild directly or from Authorized Fairchild Distributors are genuine parts, have full traceability, meet Fairchild's quality standards for handling and storage and provide access to Fairchild's full range of up-to-date technical and product information. Fairchild and our Authorized Distributors will stand behind all warranties and will appropriately address any warranty issues that may arise. Fairchild will not provide any warranty coverage or other assistance for parts bought from Unauthorized Sources. Fairchild is committed to combat this global problem and encourage our customers to do their part in stopping this practice by buying direct or from authorized distributors.

PRODUCT STATUS DEFINITIONS

Definition of Terms

Datasheet Identification	Product Status	Definition
Advance Information	Formative / In Design	Datasheet contains the design specifications for product development. Specifications may change in any manner without notice.
Preliminary	First Production	Datasheet contains preliminary data; supplementary data will be published at a later date. Fairchild Semiconductor reserves the right to make changes at any time without notice to improve design.
No Identification Needed	Full Production	Datasheet contains final specifications. Fairchild Semiconductor reserves the right to make changes at any time without notice to improve the design.
Obsolete	Not In Production	Datasheet contains specifications on a product that is discontinued by Fairchild Semiconductor. The datasheet is for reference information only.

Rev. I77