

Power Splitter/Combiner

SYPS-2-52HP+

2 Way-0° 50Ω 10 to 540 MHz 15 Watt

Maximum Ratings

Operating Temperature	-40°C to 65°C
Storage Temperature	-55°C to 100°C
Power Input (as a splitter) ¹	15W max.
Internal Dissipation	6W max.
Permanent damage may occur if any of these limits are exceeded.	

Pin Connections

SUM PORT	1
OUTPUT PORT 1	4
OUTPUT PORT 2	5
GROUND	2,3,6,7
ISOLATION (NOT USED)	8

Outline Drawing

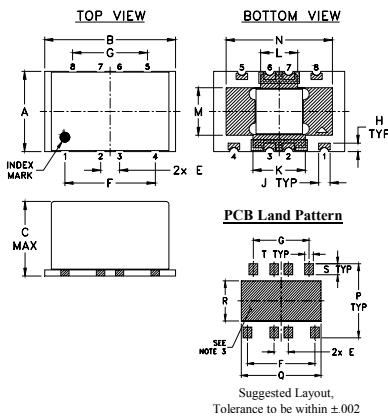

Outline Dimensions (inch/mm)

A	B	C	E	F	G	H	J	K
.433	.690	.415	.100	.476	.394	.045	.060	.276
11.00	17.53	10.54	2.54	12.09	10.01	1.14	1.52	7.01
L	M	N	P	Q	R	S	T	wt
.194	.257	.560	.475	.561	.258	.069	.061	grams
4.93	6.53	14.22	12.07	14.25	6.55	1.75	1.55	2.80

Demo Board MCL P/N: TB-655+ Suggested PCB Layout (PL-359)

Refer to Application Note: [AN-00-017](#)

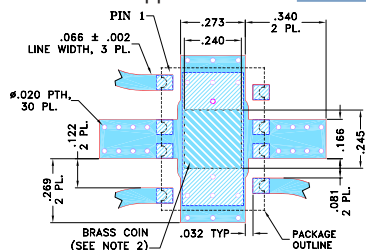

- NOTES:
- TRACE WIDTH IS SHOWN FOR ROGERS RO4350B WITH DIELECTRIC THICKNESS .030" ± .002"; COPPER: 1/2 OZ. EACH SIDE. FOR OTHER MATERIALS TRACE WIDTH MAY NEED TO BE MODIFIED.
 - SUGGEST TO PROVIDE BRASS COIN FOR BETTER HEAT TRANSFER FROM THE UNIT. OTHERWISE PROVIDE ARRAY OF THERMAL VIAS ADEQUATE TO LIMIT TEMPERATURE OF GROUND CONNECTIONS UNDER THE UNIT TO 65°C.
 - BOTTOM SIDE OF THE PCB IS CONTINUOUS GROUND PLANE.

- DENOTES PCB COPPER LAYOUT WITH SMOBC (SOLDER MASK OVER BARE COPPER)
- DENOTES COPPER LAND PATTERN FREE OF SOLDER MASK
- DENOTES BRASS COIN.

Notes

- Performance and quality attributes and conditions not expressly stated in this specification document are intended to be excluded and do not form a part of this specification document.
- Electrical specifications and performance data contained in this specification document are based on Mini-Circuit's applicable established test performance criteria and measurement instructions.
- The parts covered by this specification document are subject to Mini-Circuit's standard limited warranty and terms and conditions (collectively, "Standard Terms"); Purchasers of this part are entitled to the rights and benefits contained therein. For a full statement of the Standard Terms and the exclusive rights and remedies thereunder, please visit Mini-Circuit's website at www.minicircuits.com/MCLStore/terms.jsp

Features

- wideband, 10 to 540 MHz
- low insertion loss, 0.5 dB typ.
- excellent amplitude unbalance, 0.1 dB typ.
- high power input, 15 Watt
- high power combiner, 3 Watt each port
- good isolation, 20 dB typ.

Applications

- VHF/UHF
- communications systems
- receivers & transmitters
- instrumentation
- military mobile



Generic photo used for illustration purposes only

CASE STYLE: AH1647

+RoHS Compliant

The +Suffix identifies RoHS Compliance. See our web site for RoHS Compliance methodologies and qualifications

Electrical Specifications at 25°C

Parameter	Frequency (MHz)	Min.	Typ.	Max.	Unit
Frequency Range		10		540	MHz
Insertion Loss Above 3.0 dB	10-30	—	0.2	0.5	dB
	30-250	—	0.3	0.7	
	250-540	—	0.5	1.1	
Isolation	10-30	14	19	—	dB
	30-250	18	25	—	
	250-540	15	19	—	
Phase Unbalance	10-30	—	2	5	Degree
	30-250	—	1	4	
	250-540	—	1.5	5	
Amplitude Unbalance	10-30	—	0.15	0.4	dB
	30-250	—	0.1	0.4	
	250-540	—	0.1	0.4	
VSWR (Port S)	10-30	—	1.2	1.4	:1
	30-250	—	1.25	1.45	
	250-540	—	1.35	1.65	
VSWR (Port 1-2)	10-30	—	1.4	1.9	:1
	30-250	—	1.1	1.3	
	250-540	—	1.1	1.3	
IP3	10-30	45	50	—	dBm
	30-540	52	60	—	

1. The user must provide adequate means of heat removal to limit the temperature of ground connections under the PCB to 70°C, in order to ensure proper performance. At 25°C ambient temperature this requires thermal resistance of the user's PC board heat sink to be 8°C/W.

electrical schematic



Typical Performance Data

Frequency (MHz)	Total Loss ¹ (dB)		Amplitude Unbalance (dB)	Isolation (dB)	Phase Unbalance (deg.)	VSWR S	VSWR 1	VSWR 2
	S-1	S-2						
10.00	3.03	3.22	0.19	16.55	2.42	1.18	1.51	1.66
20.00	3.08	3.15	0.07	23.20	1.28	1.10	1.23	1.29
30.00	3.10	3.15	0.05	29.09	0.74	1.09	1.14	1.17
50.00	3.15	3.21	0.05	34.84	0.20	1.08	1.08	1.10
70.00	3.18	3.24	0.07	32.29	0.03	1.09	1.08	1.10
90.00	3.19	3.26	0.06	30.46	0.09	1.11	1.07	1.09
150.00	3.22	3.29	0.06	26.57	0.36	1.15	1.06	1.08
200.00	3.26	3.32	0.06	24.16	0.49	1.20	1.06	1.08
250.00	3.29	3.36	0.06	22.43	0.64	1.25	1.06	1.09
300.00	3.34	3.39	0.05	21.11	0.76	1.29	1.06	1.09
360.00	3.40	3.44	0.04	20.03	0.87	1.33	1.05	1.10
400.00	3.44	3.47	0.03	19.52	0.96	1.35	1.05	1.10
460.00	3.51	3.52	0.01	19.08	1.07	1.36	1.04	1.09
512.00	3.59	3.56	0.02	18.80	1.16	1.35	1.03	1.08
540.00	3.65	3.60	0.05	18.61	1.22	1.34	1.03	1.07

1. Total Loss = Insertion Loss + 3dB splitter theoretical loss.

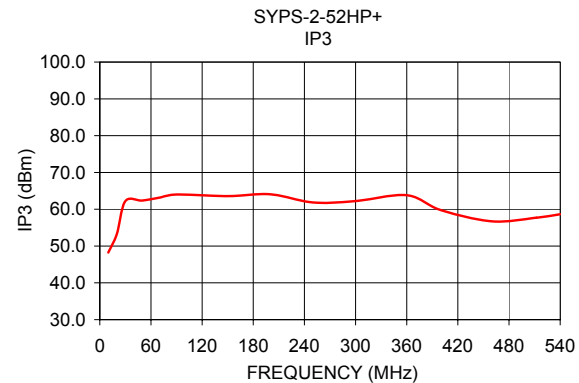
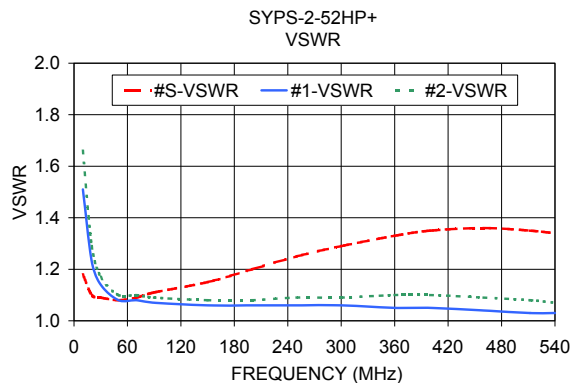
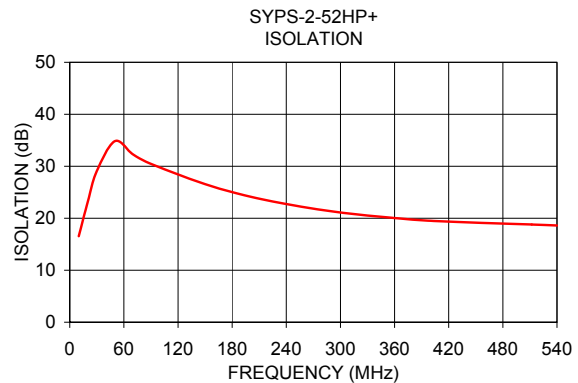
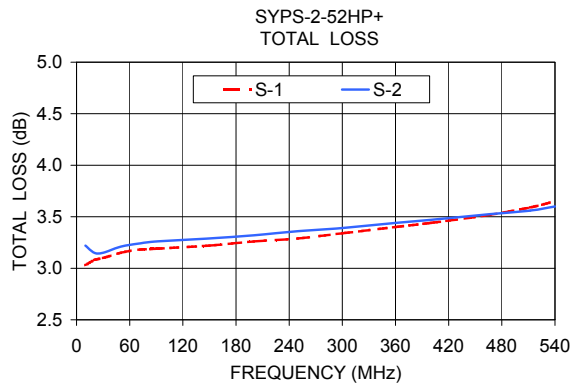

Notes

- A. Performance and quality attributes and conditions not expressly stated in this specification document are intended to be excluded and do not form a part of this specification document.
- B. Electrical specifications and performance data contained in this specification document are based on Mini-Circuit's applicable established test performance criteria and measurement instructions.
- C. The parts covered by this specification document are subject to Mini-Circuits standard limited warranty and terms and conditions (collectively, "Standard Terms"); Purchasers of this part are entitled to the rights and benefits contained therein. For a full statement of the Standard Terms and the exclusive rights and remedies thereunder, please visit Mini-Circuits' website at www.minicircuits.com/MCLStore/terms.jsp

