

QUICK START GUIDE FOR DEMONSTRATION CIRCUIT DC455

HIGH EFFICIENCY DUAL PHASE 2-OUTPUT POWER SUPPLY

LTC3707EGN

DESCRIPTION

Demonstration circuit DC455 is a dual output, step-down, synchronous buck converter featuring the 150kHz to 300kHz LTC3707EGN controller. This controller can operate with input voltages from 7V to 21V. Output 1 is

5V with loads up to 5A and output 2 is 3.3V with loads up to 5A. **Design files for this circuit board are available. Call the LTC factory.**

Table 1. Performance Summary

PARAMETER	CONDITION	VALUE
Minimum Input Voltage		7V
Maximum Input Voltage		21V
V _{OUT1}	V _{IN} = 7V to 21V, I _{OUT1} = 0A to 5A	5V%
V _{OUT2}	V _{IN} = 7V to 24V, I _{OUT1} = 0A to 5A	3.3V%
Switching Frequency	Jumper selectable	150kHz–300kHz

QUICK START PROCEDURE

Demonstration circuit DC455 is easy to set up to evaluate the performance of the LTC3707EGN. Refer to Figure 1 for proper measurement equipment setup and follow the procedure below:

NOTE: When measuring the input or output voltage ripple, care must be taken to avoid a long ground lead on the oscilloscope probe. Measure the input or output voltage ripple by touching the probe tip directly across the Vin or Vout and GND terminals. See Figure 2 for proper scope probe technique.

1. With the power off, place the jumpers as shown in Figure 1.
2. Connect the desired loads to Vout1 and Vout2. The loads can be as high as 5A for Vout1 and 5A for Vout2. Pre-set the load current to 0A.
3. Set Vin to 7V (recommended). The rated input voltage range is 7V to 21V.

4. Switch on the Vout1 channel by removing the RUN1 jumper. Vout1 should be 5V ±0.1V.
5. Increase the load current of Vout1 to 5A. At 7V input voltage, the input current should be less than 4A. Slowly increase the input voltage up to 21V. At 21V input voltage, the input current should be less than 1.5A.
6. Decrease Vout1 load current to 0A. Reduce the input voltage to 7V. Switch on the Vout2 channel by removing the RUN2 jumper. The output voltage of Vout2 should be 3.3V ±0.05V.
7. Increase the load current of Vout2 to 5A. At 7V input, the input current should be less than 3A. Slowly increase the input voltage to 21V. At 21V input, the input current should be less than 1.0A.

QUICK START GUIDE FOR DEMONSTRATION CIRCUIT DC455

HIGH EFFICIENCY DUAL PHASE 2-OUTPUT POWER SUPPLY

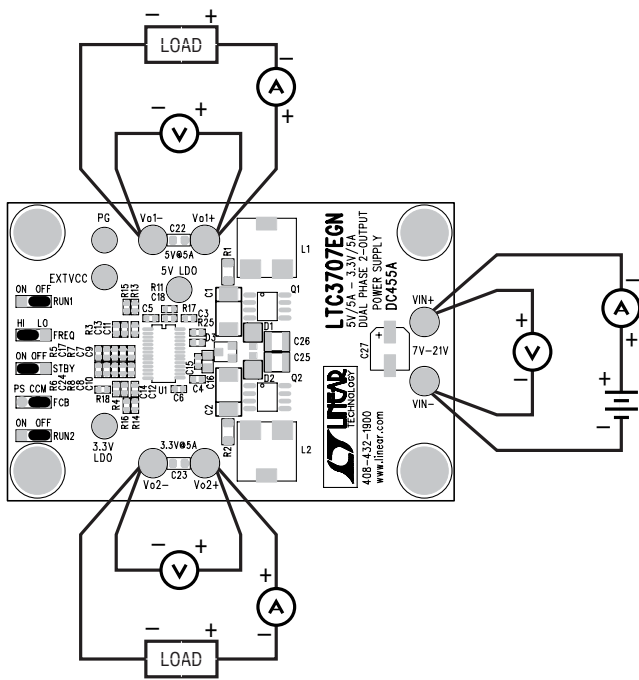

Figure 1. Proper Measurement Equipment Setup

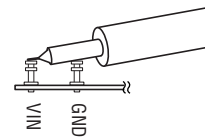
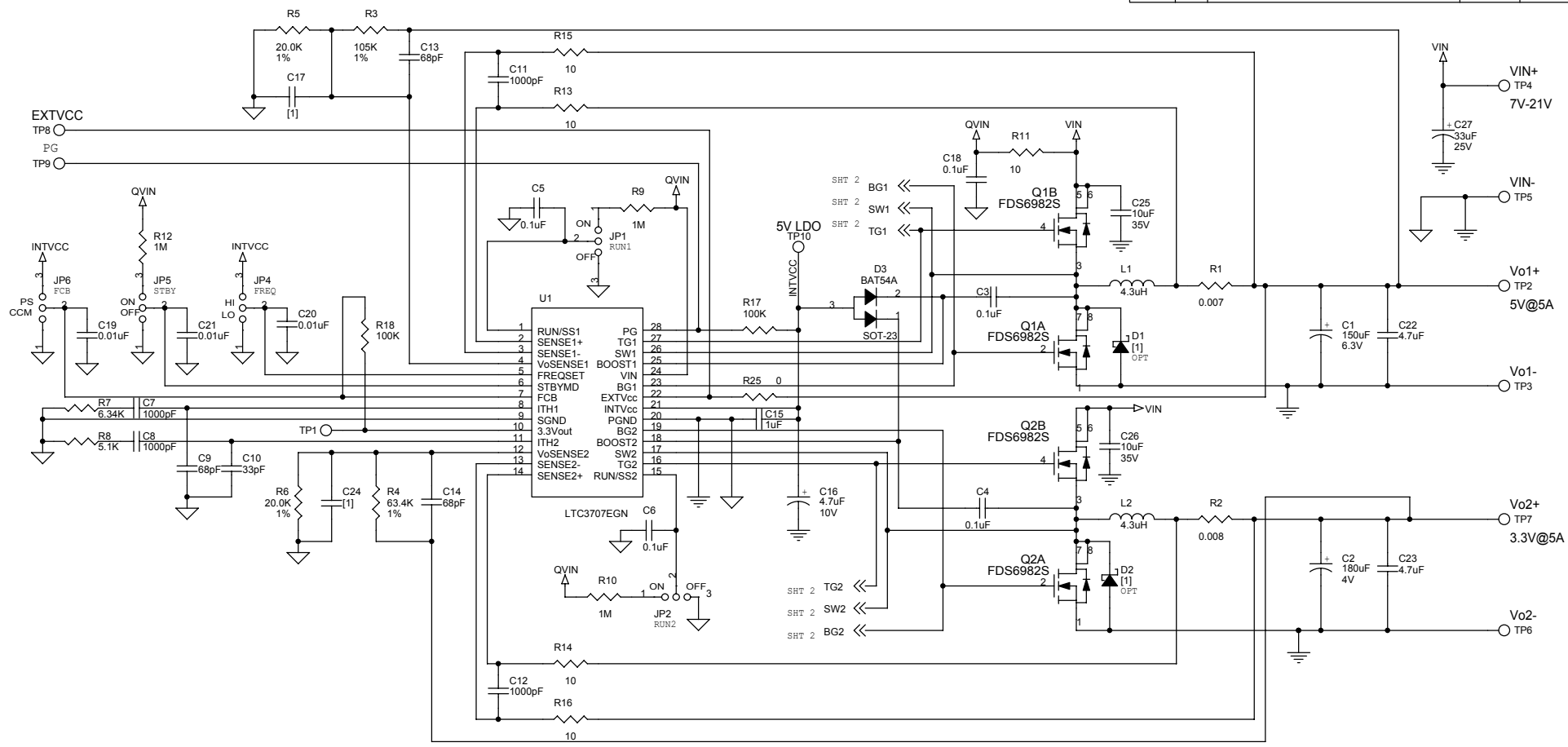

Figure 2. Scope Probe Placement for Measuring Input or Output Ripple

REVISION HISTORY				
ECO	REV	DESCRIPTION	DATE	APPROVED
0	3	PRODUCTION RELEASE	01-16-02	<



NOTES: UNLESS OTHERWISE SPECIFIED,
[1] OPTIONAL.

UNLESS OTHERWISE SPECIFIED
DIMENSIONS ARE IN INCHES
TOLERANCE ON ANGLE ---
2 PLACES --- 3 PLACES ---
INTERPRET DIM AND TOL
PER ASME Y14.5M -1994

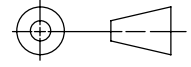

DO NOT SCALE DRAWING

CONTRACT NO.

APPROVALS DATE

DRAWN MEI 08-30-01

CHECKED

APPROVED

ENGINEER

DESIGNER

Tuesday, March 19, 2002



1630 McCarthy Blvd.
Milpitas, CA 95035
Phone: (408)432-1900
Fax: (408)434-0507

TITLE SCH_LTC3707 HIGH EFFICIENCY DUAL-PHASE, 2 OUTPUT
POWER SUPPLY

SIZE B	CAGE CODE	DWG NO DC455A	REV 3
--------	-----------	---------------	-------

SCALONE	FILENAME:455A-3.DSN	SHEET 1 OF 2
---------	---------------------	--------------

REVISION HISTORY				
ECO	REV	DESCRIPTION	DATE	APPROVED
0	3	PRODUCTION RELEASE	01-16-02	<

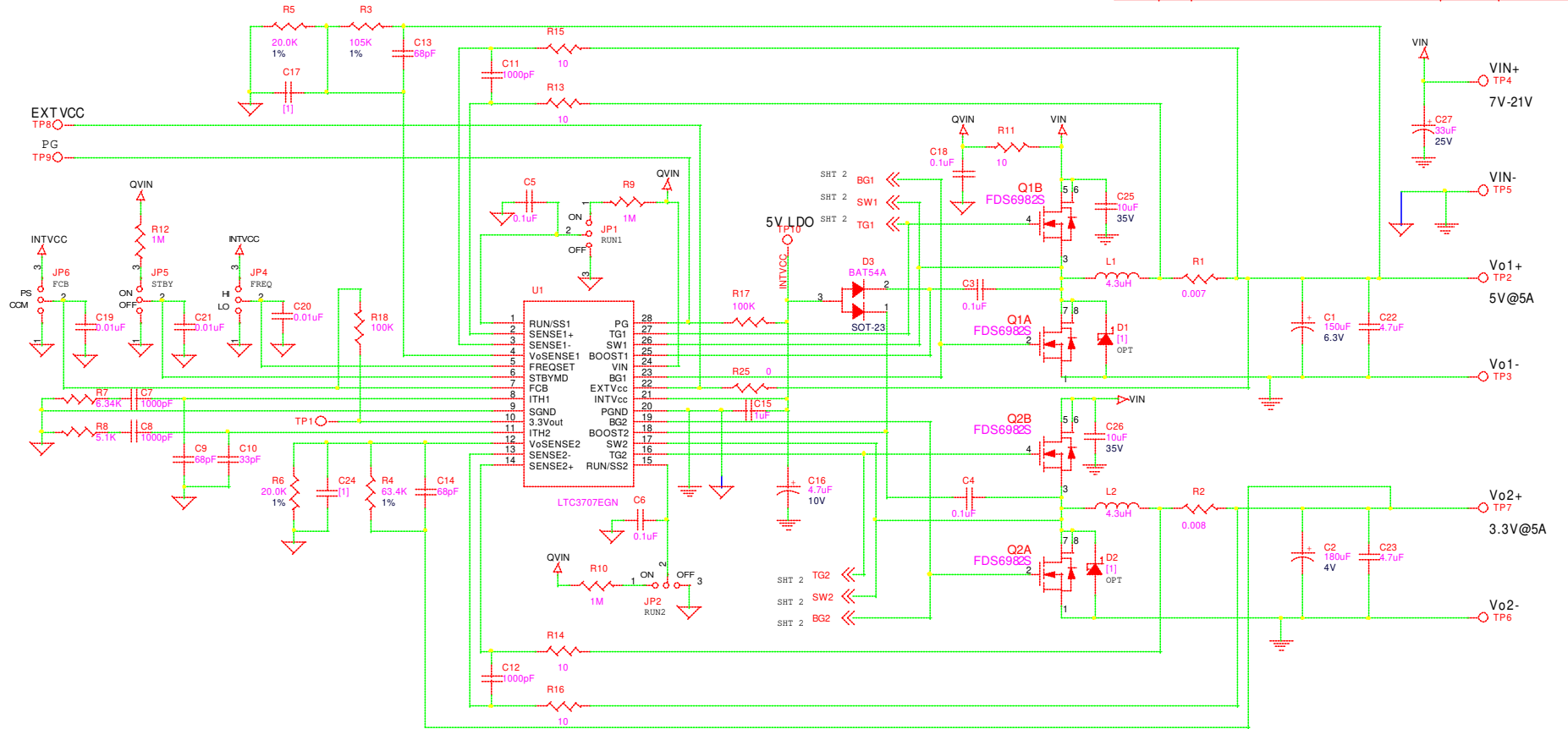

NOTES: UNLESS OTHERWISE SPECIFIED,
 [1] OPTIONAL.

UNLESS OTHERWISE SPECIFIED DIMENSIONS ARE IN INCHES TOLERANCE ON ANGLE --- 2 PLACES --- 3 PLACES --- INTERPRET DIM AND TOL PER ASME Y14.5M -1994	CONTRACT NO.		1630 McCarthy Blvd. Milpitas, CA 95035 Phone: (408)432-1900 Fax: (408)434-0507
	APPROVALS DRAWN MEI CHECKED APPROVED ENGINEER DESIGNER	DATE 08-30-01	
THIRD ANGLE PROJECTION 	Tuesday, March 19, 2002	SIZE B SCALE NONE FILENAME 455A-3.DSN	DWG NO DC455A SHEET 1 OF 2
DO NOT SCALE DRAWING			REV 3

LTC CONFIDENTIAL - For Customer Use Only

REVISION HISTORY

ECO	REV	DESCRIPTION	DATE	APPROVED
	3	PRODUCTION RELEASE	01-16-02	

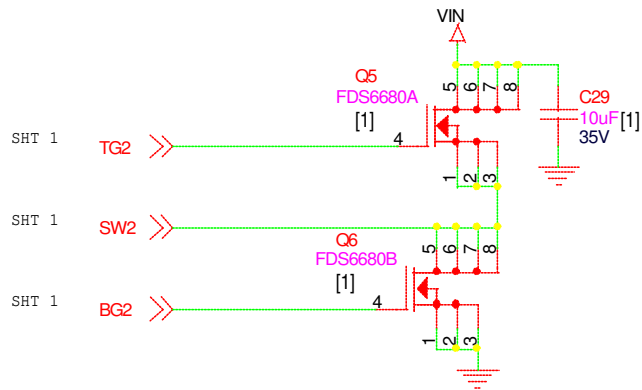
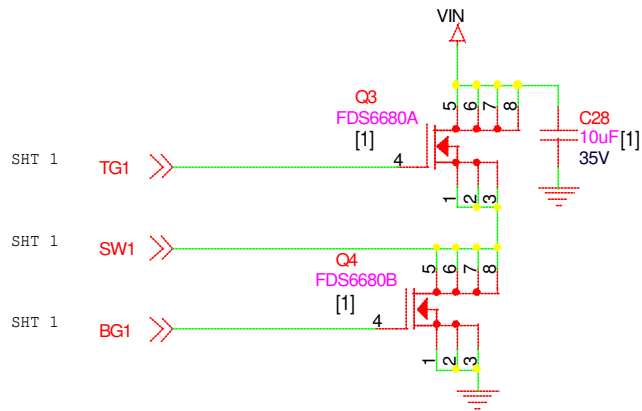

UNLESS OTHERWISE SPECIFIED
DIMENSIONS ARE IN INCHES
TOLERANCE ON ANGLE ---
2 PLACES --- 3 PLACES ---
INTERPRET DIM AND TOL
PER ASME Y14.5M -1994

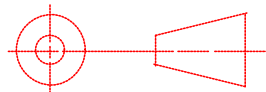

DO NOT SCALE DRAWING

CONTRACT NO.

APPROVALS	DATE
DRAWN MEI	01-16-02
CHECKED	
APPROVED	
ENGINEER	
DESIGNER	

Monday, January 28, 2002



1630 McCarthy Blvd.
Milpitas, CA 95035
Phone: (408)432-1900
Fax: (408)434-0507

TITLE SCH,LTC3707 HIGH EFFICIENCY DUAL PHASE, 2 OUTPUT
POWER SUPPLY

SIZE	CAGE CODE	DWG NO	REV
A		DC455A	3

SCALE:NONE FILENAME: 455A-3.DSN SHEET 2 OF 2

Item	Qty	Ref	Desc	Part Number
1	1	C1	CAP, SPCL PLYMR 150uF 6.3V 20% 7343	PANASONIC EEFUE0J151R
2	1	C2	CAP, SPCL PLYMR 180uF 4V 20% 7343	PANASONIC EEFUE0G181R
3	5	C3,C4,C5,C6,C18	CAP, X7R 0.1uF 10V 20% 0603	AVX 0603ZC104MAT1A
5	3	C9,C13,C14	CAP, NPO 68pF 50V 5% 0603	AVX 06035A680JAT2A
6	1	C10	CAP, NPO 33pF 50V 5% 0603	AVX 06035A330JATA1A
7	4	C7,C8,C11,C12	CAP, NPO 1000pF 25V 5% 0603	AVX 06033A102JAT1A
8	1	C15	CAP, X5R 1uF 6.3V 10% 0603	AVX 06036D105KAT
9	1	C16	CAP, TANT 4.7uF 10V 20% 0805	AVX TACR475M010R
10	0	C24,C17,C28,C29	DO NOT STUFF	OPTION
11	3	C19,C20,C21	CAP, X7R 0.01uF 10V 10% 0603	AVX 0603ZC103KAT1A
12	2	C23,C22	CAP, X5R 4.7uF 6.3V 20% 0805	TAIYO YUDEN JMK212BJ475MG-T
13	2	C25,C26	CAP, Y5V 10uF 35V 1210	MURATA GRM235Y5V106Z035
14	1	C27	CAP, ELECTROLYTIC 33uF 25V 20%	SANYO 25CV33AX
15	0	D1,D2	DIODE, MBRM140T3 SCHOTTKY DO-216AA (OPTIONAL)	MOTOROLA MBRM140T3
16	1	D3	DIODE, BARRIER DOUBLE DIODES BAT54A SOT-23	DIODES INC. BAT54A
17	5	JP1,JP2,JP4,JP5,JP6	HEADER, 3PIN, 2mm	COMM CON 2802S-03G2
18	2	L1,L2	IND, 4.3uH	SUMIDA CDEP105-4R3MC-88
20	2	Q2,Q1	XSTR, FDS6982S DUAL N-FET 6.3A SO8	FAIRCHILD FDS6982S
21	0	Q3,Q5	XSTR, FDS6680A N-CHANNEL POWER MOSFET SO8 (OPTIONAL)	FAIRCHILD FDS6680A
22	0	Q4,Q6	XSTR, FDS6680B N-CHANNEL POWER MOSFET SO8 (OPTIONAL)	FAIRCHILD FDS6680B
23	1	R1	RES, 0.007 OHM 5% 1/4W 1206	IRC LRF1206-01-R007
24	1	R2	RES, 0.008 OHM 5% 1/4W 1206	IRC LRF1206-01-R008
25	1	R3	RES, 105K OHM 1% 1/16W 0603	AAC CR16-1053FM
26	1	R4	RES, 63.4K OHM 1% 1/16W 0603	AAC CR16-6342FM
27	2	R5,R6	RES, 20.0K OHM 1% 1/16W 0603	AAC CR16-2002FM
28	1	R7	RES, 6.34K OHM 1% 1/16W 0603	AAC CR16-6341FM
29	1	R8	RES, 5.1K OHM 5% 1/16W 0603	AAC CR16-512JM
30	3	R9,R10,R12	RES, 1M OHM 5% 1/16W 0603	AAC CR16-105JM
31	5	R11,R13,R14,R15,R16	RES, 10 OHM 5% 1/16W 0603	AAC CR16-100JM
32	2	R18,R17	RES, 100K OHM 5% 1/16W 0603	AAC CR16-104JM
33	1	R25	RES, 0 OHM 1/16W JUMPER 0603	AAC CJ06-000M
34	4	TP1,TP8,TP9,TP10	TURRET, .061	MILL-MAX 2308-2-00-44
35	6	TP2,TP3,TP4,TP5,TP6,TP7	TURRET, .090	MILL-MAX 2501-2
36	1	U1	IC, LTC3707EGN DUAL PHASE DUAL OUTPUT SYNC BUCK CONTROLLER	LINEAR TECH LTC3707EGN
	4		SCREW, 4-40 1/4"	ANY
	4		STANDOFF, NYLON 4-40 1/4"	?