

NOTES:

1. MATERIALS AND FINISHES:
 BODY - BRASS, MATTE TIN PLATING
 HEX NUT, CAP &
 RETAINING RING - BRASS, NICKEL PLATING
 LOCKWASHER - PHOSPHOR BRONZE, NICKEL PLATING
 INSULATORS - PTFE, NATURAL
 CONTACT - BeCu, GOLD PLATING
 CONTACT REAR - BRASS, GOLD PLATING
2. ELECTRICAL:
 A. IMPEDANCE: 75 OHM
 B. FREQUENCY RANGE: DC - 12 GHz

3. MAX. PANEL THICKNESS : 1,52 [0.060] MAX.
4. MECHANICAL:
 A. DURABILITY: 500 CYCLES MIN.
 B. TEMPERATURE RANGE: -65°C TO +165°C

THIRD ANGLE PROJ.

REV		DESCRIPTION	DATE	ECO	APPR
A		RELEASE TO MFG.	11-May-17	03743	BMG
B		ADD CHAMFER TO BODY FOR OPTIMIZE STRUCTURE	16-Aug-17	04843	KEN

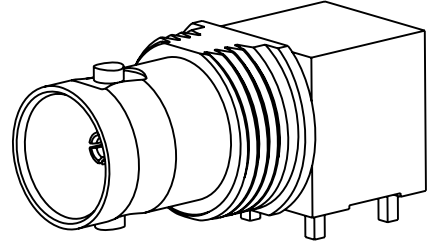

SCALE 2.000

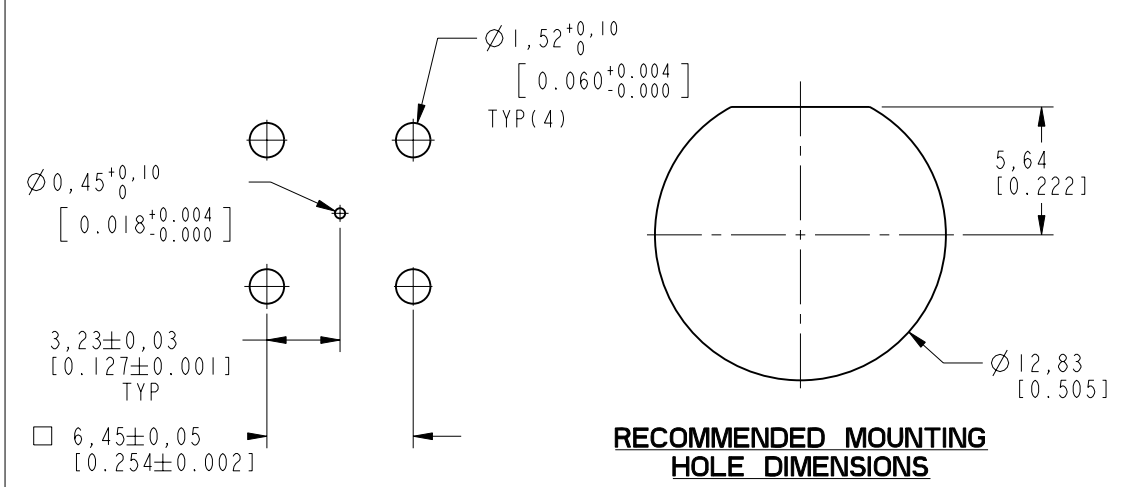
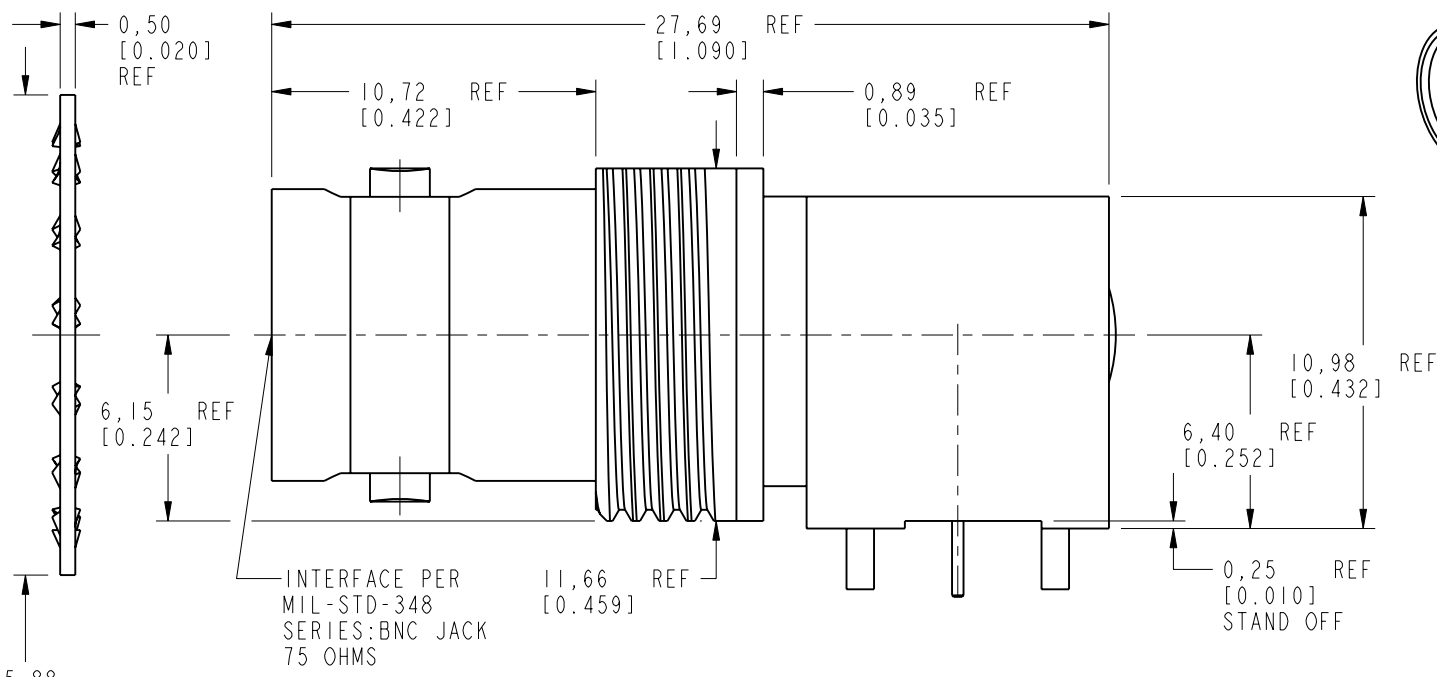
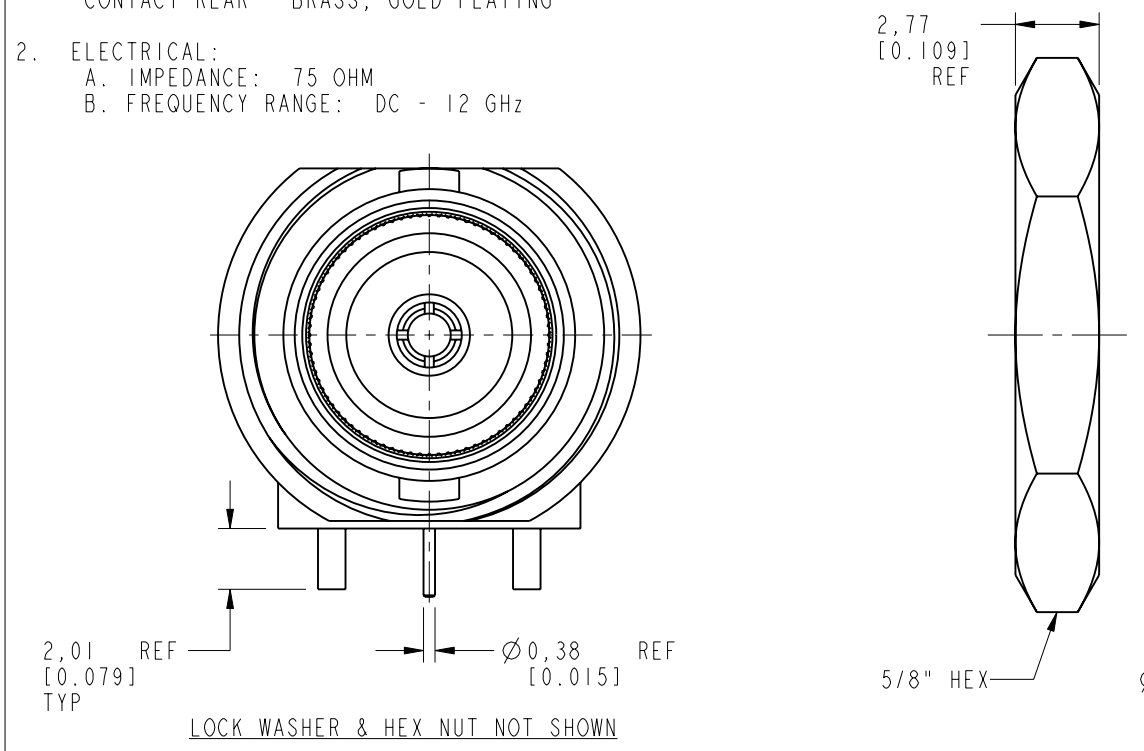

RECOMMENDED MOUNTING HOLE DIMENSIONS

RECOMMENDED PCB HOLE DIMENSIONS

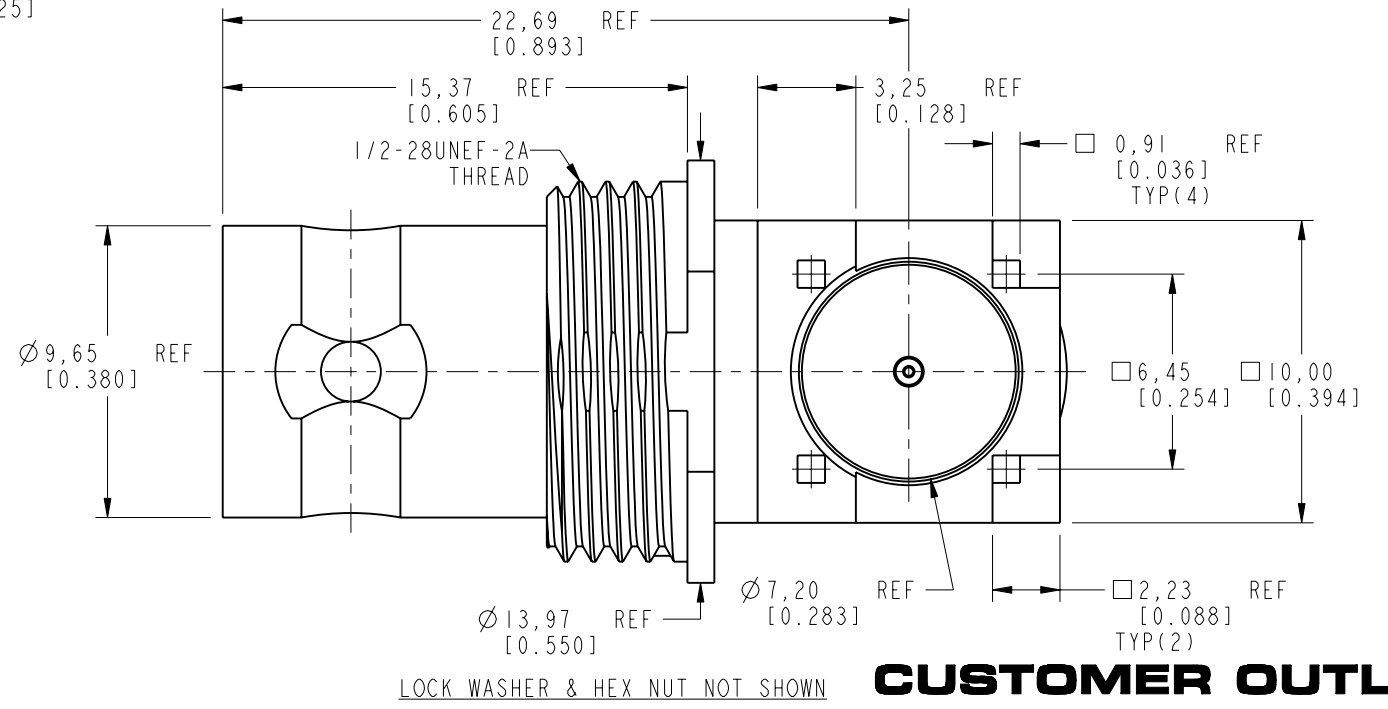

LOCK WASHER & HEX NUT NOT SHOWN

CUSTOMER OUTLINE DRAWING
 ALL OTHER SHEETS ARE FOR INTERNAL USE ONLY

UNLESS OTHERWISE SPECIFIED, DIMENSIONS ARE IN METRIC AND TOLERANCES ARE:
 <0.5mm ± 0.05mm 0.5 - 6mm ± 0.1mm 6 - 30mm ± 0.2mm 30 - 120mm ± 0.3mm ANGLES ± 1°

NOTICE - These drawings, specifications, or other data (1) are, and remain the property of Amphenol corp. (2) must be returned upon request; and (3) are confidential and not to be disclosed to any person other than those to whom they are given by Amphenol Corp. the furnishing of these drawings, specifications, or other data by Amphenol Corp., or to any other person to anyone for any purpose is not to be regarded by implication or otherwise in any manner licensing, granting rights to permitting such holder or any other person to manufacture, use or sell any product, process or design, patented or otherwise, that may in any way be related to or disclosed by said drawings, specifications, or other data.

MATERIAL	SEE NOTES
EAR#	7476
REF:	
CONFIGURATION LEVEL:	In Work
FINISH	

DRAWN	K. SONG	DATE	24-Aug-17
ENGINEER	MADHAN G	DATE	02-Dec-16
APPROVED	S. HSIEH	DATE	24-Aug-17
CAD FILE			

TITLE		75 OHM BNC RA BHD JACK PCB MOUNT	
SCALE:	4.0:1.0	SHEET	2 OF 2
DWG SIZE	B	REV	B

Amphenol RF	
www.amphenolrf.com	
DRAWING NO.	31-70535-12G
ITEM NO.	31-70535-12G
PART NO.	31-70535-12G